

# **ELATION®**

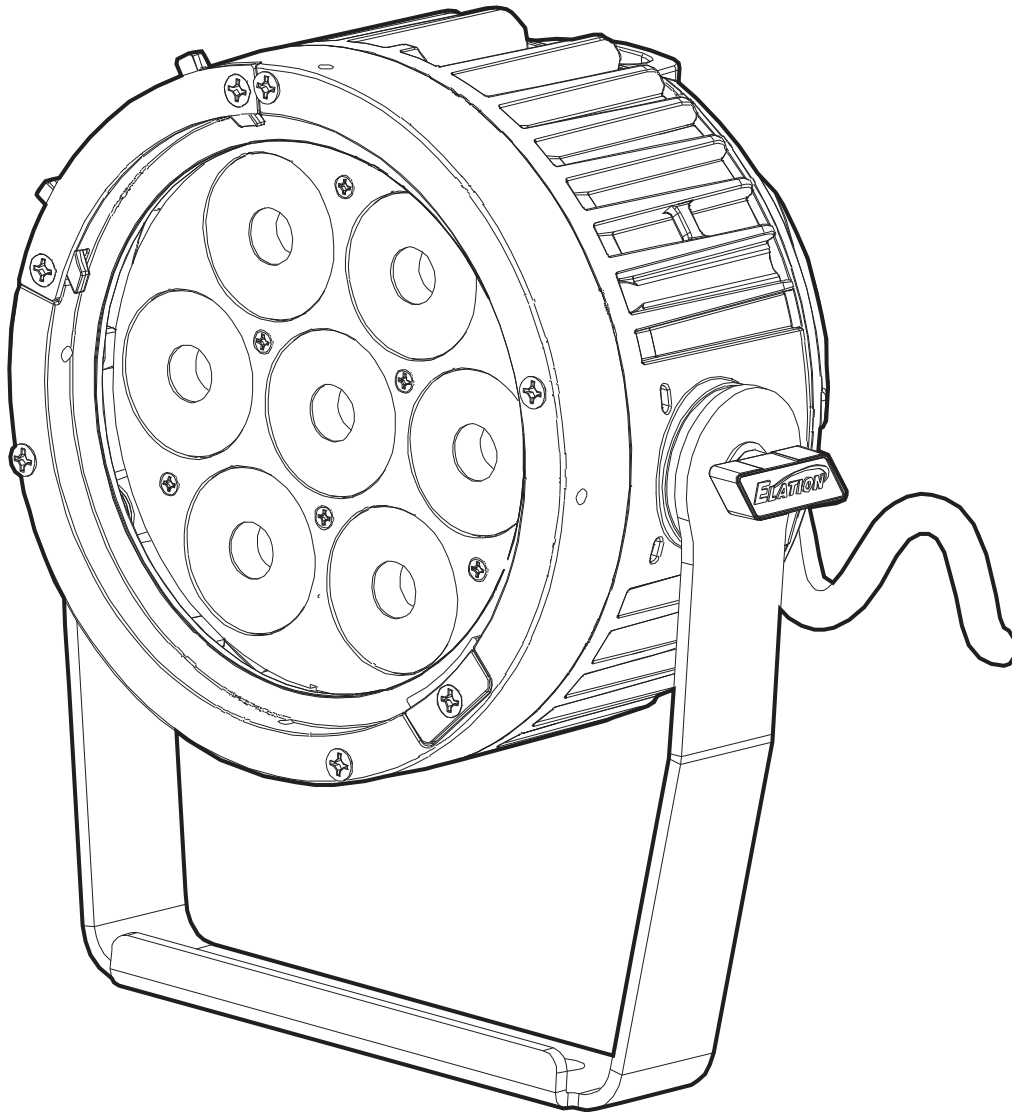

## **SIX+ PAR S**



## User Manual

©2025 ELATION PROFESSIONAL all rights reserved. Information, specifications, diagrams, images, and instructions herein are subject to change without notice. ELATION PROFESSIONAL logo and identifying product names and numbers herein are trademarks of ELATION PROFESSIONAL. Copyright protection claimed includes all forms and matters of copyrightable materials and information now allowed by statutory or judicial law or hereinafter granted. Product names used in this document may be trademarks or registered trademarks of their respective companies and are hereby acknowledged. All non-ELATION brands and product names are trademarks or registered trademarks of their respective companies.

**ELATION PROFESSIONAL** and all affiliated companies hereby disclaim any and all liabilities for property, equipment, building, and electrical damages, injuries to any persons, and direct or indirect economic loss associated with the use or reliance of any information contained within this document, and/or as a result of the improper, unsafe, insufficient and negligent assembly, installation, rigging, and operation of this product.

**Elation Professional USA | 6122 S. Eastern Ave. | Los Angeles, CA. 90040**

323-582-3322 | 323-832-9142 fax | [www.elationlighting.com](http://www.elationlighting.com) | [info@elationlighting.com](mailto:info@elationlighting.com)

**Elation Professional B.V. | Junostraat 2 | 6468 EW Kerkrade, The Netherlands**

+31 45 546 85 66 | +31 45 546 85 96 fax | [www.elationlighting.eu](http://www.elationlighting.eu) | [info@elationlighting.eu](mailto:info@elationlighting.eu)

**Elation Professional Mexico | AV Santa Ana 30 | Parque Industrial Lerma, Lerma, Mexico 52000**

+52 (728) 282-7070

**DOCUMENT VERSION**



Due to additional product features and/or enhancements, an updated version of this document may be available online. Please scan the QR Code with your mobile device or visit [www.elationlighting.com](http://www.elationlighting.com) for the latest revision/update of this manual, before installation and/or programming.

Date	Document Version	Software Version	DMX Channel Mode	Notes
02/12/25	1.0	1.01	1/3/9/6/9/11/14/14/20	Initial Release

# CONTENTS

<b>General Information</b>	<b>4</b>
<b>IP65 Rated</b>	<b>5</b>
<b>Limited Warranty (USA Only)</b>	<b>6</b>
<b>Safety Guidelines</b>	<b>8</b>
<b>Overview</b>	<b>10</b>
<b>Torque Settings for Screws</b>	<b>11</b>
<b>IP Test Parameters</b>	<b>12</b>
<b>Installation Guidelines</b>	<b>13</b>
<b>Accessory Installation</b>	<b>17</b>
<b>Remote Device Management (RDM)</b>	<b>20</b>
<b>Dimmer Modes &amp; Curves</b>	<b>21</b>
<b>DMX Traits</b>	<b>22</b>
<b>Emulation DMX Traits</b>	<b>26</b>
<b>Color Temperature Chart</b>	<b>28</b>
<b>Virtual Colors Chart</b>	<b>29</b>
<b>Software Updates</b>	<b>30</b>
<b>Maintenance Guidelines</b>	<b>31</b>
<b>Specifications</b>	<b>32</b>
<b>Dimensional Drawings</b>	<b>33</b>
<b>Ordering Information   Error Codes   FCC Statement</b>	<b>35</b>

# GENERAL INFORMATION

## INTRODUCTION

Please read and understand the instructions in this manual carefully and thoroughly before attempting to operate this device. These instructions contain important safety and use information. **This device is intended for use by trained personnel only, and is not suitable for private use.**

## UNPACKING

Every device has been thoroughly tested and has been shipped in perfect operating condition. Carefully check the shipping carton for damage that may have occurred during shipping. If the carton is damaged, carefully inspect the device for damage, and be sure all accessories necessary to install and operate the device have arrived intact. In the event damage has been found or parts are missing, please contact our customer support team for further instructions. Please do not return this device to your dealer without first contacting customer support. Please do not discard the shipping carton in the trash. Please recycle whenever possible.

## BOX CONTENTS

Gel Frame and Holder Kit (x1)  
Safety Cable (x1)  
Power Cable (x1)

## CUSTOMER SUPPORT

Contact ELATION Service for any product related service and support needs. Also visit [forums.elationlighting.com](https://forums.elationlighting.com) with questions, comments, or suggestions.

**ELATION SERVICE USA - Monday - Friday 8:00am to 4:30pm PST**  
323-582-3322 | Fax 323-832-9142 | [support@elationlighting.com](mailto:support@elationlighting.com)

**ELATION SERVICE EUROPE - Monday - Friday 08:30 to 17:00 CET**  
+31 45 546 85 63 | Fax +31 45 546 85 96 | [support@elationlighting.eu](mailto:support@elationlighting.eu)

**REPLACEMENT PARTS** please visit [parts.elationlighting.com](https://parts.elationlighting.com)



## IMPORTANT NOTICE!

**THERE ARE NO USER SERVICEABLE PARTS INSIDE THIS UNIT. DO NOT ATTEMPT ANY REPAIRS YOURSELF; DOING SO WILL VOID YOUR MANUFACTURER'S WARRANTY. DAMAGES RESULTING FROM MODIFICATIONS TO THIS FIXTURE AND/OR THE DISREGARD OF SAFETY INSTRUCTIONS AND GUIDELINES IN THIS MANUAL VOID THE MANUFACTURER'S WARRANTY AND ARE NOT SUBJECT TO ANY WARRANTY CLAIMS AND/OR REPAIRS.**

# IP65 RATED

**The International Protection (IP)** rating system is commonly expressed as “IP” (Ingress Protection) followed by two numbers (i.e. IP65), where the numbers define the degree of protection. The first digit (Foreign Bodies Protection) indicates the extent of protection against particles entering the fixture, and the second digit (Water Protection) indicates the extent of protection against water entering the fixture. An **IP65** rated lighting fixture is designed and tested to protect against the ingress of dust (**6**), and low-pressure water jets from any direction (**5**).

**Maritime/Coastal Environment Installations:** A coastal environment is seaside adjacent, and caustic to electronics through exposure to atomized salt-water and humidity, whereas maritime is anywhere within 5-miles of a coastal environment.

Maritime installations require additional preparation, and additional service intervals may be needed given the maritime use. In general, IP ratings presuppose freshwater conditions VS maritime conditions, which are typically more “caustic” to IP fixtures (both internally and externally). A duty-cycle may also be needed when units are not in use. During times of high humidity and colder temperatures, condensation may occur internally so the fixture may require a duty-cycle to bring it up to running temperature, allowing any accumulation of moisture to be expelled via the vent valve. Recommendations can change based on installation environmental circumstances.

**NOTE: NOT ALL FEATURES LISTED ARE AVAILABLE ON ALL FIXTURES; THE FOLLOWING INSTRUCTIONS MAY NOT APPLY. CONTACT SUPPORT FOR ADDITIONAL DETAILS.**

**Exterior Maintenance:** Inspect the exterior every 30-days. The unit must be powered off/disconnected. The chassis should be inspected for any signs of contaminants. Inspect optics to determine if the lens is obstructed, then clean optics and chassis accordingly. Based on initial finding, schedule maintenance accordingly, keeping in mind that exterior maintenance will be required. Even if the luminaires are NOT in use, maintenance will still be needed given its location (exterior use). The use of a durable type of wax on the chassis is recommended since it will help prevent contaminant build up. Inspect both power and data lines for any signs of contaminants or corrosion. Periodically reapplying di-electric grease, especially in coastal environments. If any signs of corrosion/contaminants are present, clean thoroughly, and/or replace connectors, then reapply di-electric grease. Typically, this should be done annually, or any time an opportunity presents itself. As a preventive measure, annual replacement of both vent valves is recommended. The vent valve membrane can become contaminated and/or clogged causing improper venting of humidity within the luminaire. Inspect all mounting hardware as a precaution.

**Interior Maintenance:** Inspect the interior every 30-days. The unit must be powered off/disconnected.

- Inspect zoom/focus mechanism, clean optics, lubricate linear bearings (Krytox oil) as needed, inspect belts for wear
- Inspect all rotating effect wheels, manually rotate them, note any resistance
- Inspect all remaining rotating belts for any wear
- Inspect all fans, clean as needed, check rotation, check connections
- Inspect CMY module, manually move flags and check for signs of resistance, and if needed, clean guide rods first, then reapply a thin layer of grease (moly lube)
- Clean interior with low-volume compressed air, then clean optics prior to reassembly of head covers

Although the base has limited moving parts, the pan belt should also be inspected for wear. Remember to always perform an IP test anytime a cover is removed.

There is no specific time frame regarding the routine replacement of parts such as belts/stepper motors, PCBs, or LEDs. These items should only be replaced on an as needed bases, except for cooling fans, which should be replaced once the luminaries reach 10,000-hours. This is a prophylactic measure intended to keep the unit running as cool as possible, insuring proper function of all internal components. A complete service breakdown is available, please contact [service@elationlighting.com](mailto:service@elationlighting.com) for any needed parts or manuals.

# LIMITED WARRANTY (USA ONLY)

ELATION Professional (“ELATION”) hereby warrants to the original purchaser/owner (“Customer”) that ELATION products are free of manufacturing defects in materials and workmanship for the warranty periods defined below from the original purchase invoice date. This warranty applies exclusively to new ELATION-branded and/or distributed products listed below, purchased from an authorized ELATION dealer within the United States of America, including possessions and territories. This warranty is not transferable and may or may not apply to products sold and/or forwarded outside the United States. Please contact ELATION for applicable regional product warranty information.

1. To obtain warranty service, a Return Materials Authorization (RMA) number must first be obtained from ELATION. The Customer must provide product proof of purchase and serial number by acceptable evidence such as an invoice copy or an approved ELATION Extended Warranty Certificate (“EWC”) and any relevant maintenance records at the time warranty service is sought. Failure to provide acceptable evidence of product proof of purchase or EWC and any relevant maintenance records may result in a denial of warranty service. Products returned for warranty service must be sent without any accessories, must be boxed using the original and/or suitable packaging materials that provide ample product protection for ground and/or air freight transit, and must be shipped freight pre-paid and insured to ELATION in Los Angeles, CA, or an ELATION Authorized Service Center. The RMA number must be clearly written on the outside of the return box, and a brief description of the problem and the RMA number must be documented and included in the box. Products returned for warranty service without an RMA number clearly marked on the outside of the package will be refused and returned to the shipper at the Customer’s expense. Products returned for warranty service, which are received damaged due to inadequate and/or improper packaging and/or due to damage caused by shipping carrier, may incur additional repair charges before warranty service begins and/or may void this warranty. If any product accessories (included and/or optional) are shipped with the product, ELATION and/or the ELATION Authorized Service Center shall have no liability whatsoever for the loss and/or damage to any such accessories, nor the safe return thereof. If the requested warranty repairs or service (including parts replacement) are within the terms of this warranty, ELATION will pay return ground transportation shipping charges to a single designated point within the United States.
2. This warranty is void if the product serial number and/or product labels have been altered, removed, damaged, and/or rendered defective; if the product is modified in any manner that affects the reliability, safety, product certifications, and/or ratings of the product; if the product has been repaired and/or serviced by anyone other than ELATION and/or an ELATION Authorized Service Center, unless prior written authorization was issued to the purchaser/owner by ELATION; if the product damage is as a result of the use of parts not manufactured, sold, or recommended by ELATION and/or in connection with the integration of any third-party equipment, accessory, and software not sold, distributed, or approved by ELATION; if the product damage is as a result of willful and/or accidental damage, negligence, misuse, abuse, and/or failure to use the product in a safe and reasonable manner; if product damage is as a result of improper and/or negligent installation, maintenance, transportation, shock, vibration, storage, and handling; if the product is exposed to and/or damaged by dust/dirt and/or fluid/moisture ingress exceeding the product’s ingress protection (“IP”) rating, abnormal voltage, harmonic distortion, corrosion, extreme atmospheric and environmental temperatures, humidity, and/or thermal conditions including salinity and pressure, light beams from direct sunlight, moving head lighting fixtures, or any other intense focused light or laser sources focused directly towards the exterior housing and/or penetrate the front lens; if product damage is as a result of an act of God or due to the use of the product in a manner it was not intended for.
3. This warranty is not a service contract and does not cover any periodic fixture maintenance, calibration, adjustment, testing, and cleaning. This warranty does not cover or include parts prone to wear and tear, including but not limited to fuses, discharge lamps (except MSD Platinum Flex, Philips MSD Platinum 200 FLEX in Smart Hybrid, and Philips MSD Platinum 400L FLEX in Smarty Max when used as directed in the user manual), lamp sockets, seals, screws, LED fan kits, and does not cover organic light output degradation (up to 30% for LED, and up to 50% for Philips Flex Lamps during product lifetime) and/or variances in specified values of intensity and color which does not affect the functionality of the product over the course of normal professional entertainment use. During the specific warranty periods stated above, ELATION and/or an ELATION Authorized Service Center will provide warranty service including defective parts replacement and will absorb parts and labor costs at its expense as per the defined coverage for each product/series listed above, including return ground transportation shipping charges for warranty serviced products to a single designated point within the United States, only if due to reasons of manufacturing defects in materials and workmanship as found after incident review and product inspection at ELATION in Los Angeles, CA or at an ELATION Authorized Service Center. ELATION reserves the right to use new, factory repaired, or certified pre-owned parts, sub-assemblies, modules, and components in the repair or replacement of any product covered by this warranty. The sole responsibility of ELATION and/or the ELATION Authorized Service Center

# LIMITED WARRANTY (USA ONLY)

under this warranty shall be limited to the repair of the product or replacement thereof, including parts at the sole discretion of ELATION. At no time will ELATION and/or the ELATION Professional Authorized Service Center assume or be responsible for any de-installation or installation labor and/or liability costs of products covered by this warranty. This warranty does not include loaner/rental products while warranty product is being inspected and/or serviced.

4. ELATION reserves the right to make product design modifications and/or performance improvements without prior notice and without any obligation to include these changes in any products theretofore manufactured.
5. Outdoor Permanent, Marine, or extreme weather location applications using ELATION Professional products are subject to a 5-year limited warranty, and ELATION must be notified prior to delivery of units for such applications so that preventative treatment can be made to the products to ensure proper performance and product life with a special marine code coating/sealing process at an additional cost.
6. No warranty, whether expressed or implied, is given or made with respect to any product accessory supplied with the products described above. Except to the extent prohibited by applicable law, all implied warranties made by ELATION in connection with this product, including warranties of merchantability or fitness, are limited in duration to the warranty periods set forth above. No warranties, whether expressed or implied, including warranties of merchantability or fitness, shall apply to this product after said periods have expired. The Customer and ELATION's sole remedy shall be such repair or replacement as is expressly provided above; and under no circumstances shall ELATION and/or the ELATION Authorized Service Center be liable for any loss and/or damage direct and/or consequential, arising out of the use of, and/or the inability to use, this product.
7. This warranty is governed by the laws of the State of California. Any legal action or proceeding arising out of or in connection with the terms of this warranty will be brought exclusively to a court within Los Angeles County, California. The United Nations Convention on Contracts for the International Sale of Goods will not apply to the sale of any ELATION products.
8. No employee, agent, sales representative, distributor, or dealer of ELATION products has authority to change, modify, or promise any warranty terms on any ELATION products and/or services beyond the warranty terms set forth above.
9. This warranty is the only warranty applicable to ELATION products and supersedes all other prior written or electronic descriptions of warranty terms and conditions heretofore published.
10. This is ELATION's current Limited Warranty (USA) statement at the time of publication and is subject to change at any time without notice.



# SAFETY GUIDELINES

This fixture is a sophisticated piece of electronic equipment. To guarantee smooth operation, it is important to follow all instructions and guidelines in this manual. Elation Professional is not responsible for injury and/or damages resulting from the misuse of this fixture due to the disregard of the information printed in this manual. Only qualified and/or certified personnel should perform installation of this fixture and only the original rigging parts included with this fixture should be used for installation. Any modifications to the fixture and/or the included mounting hardware will void the original manufacturer's warranty and increase the risk of damage and/or personal injury.



**PROTECTION CLASS 1 - FIXTURE MUST BE PROPERLY GROUNDED.**



**THERE ARE NO USER SERVICEABLE PARTS INSIDE THIS UNIT. DO NOT ATTEMPT ANY REPAIRS YOURSELF. DOING SO WILL VOID YOUR MANUFACTURER'S WARRANTY. DAMAGES RESULTING FROM MODIFICATIONS TO THIS DEVICE AND/OR THE DISREGARD OF SAFETY INSTRUCTIONS AND GUIDELINES IN THIS MANUAL VOID THE MANUFACTURER'S WARRANTY AND ARE NOT SUBJECT TO ANY WARRANTY CLAIMS AND/OR REPAIRS.**



**DO NOT PLUG THIS UNIT INTO A DIMMER PACK  
DO NOT REMOVE THE COVER UNDER ANY CONDITIONS  
NEVER OPERATE THIS UNIT WITH THE CASING REMOVED  
UNPLUG FROM POWER DURING LONG PERIODS OF NON-USE  
DISCONNECT POWER BEFORE PERFORMING MAINTENANCE**

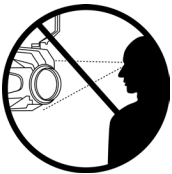

**NEVER LOOK DIRECTLY INTO THE LIGHT SOURCE!  
RETINA INJURY RISK - MAY INDUCE BLINDNESS!  
SENSITIVE PERSONS MAY SUFFER AN EPILEPTIC SHOCK!**



**FIXTURE SHOULD BE PLACED A MINIMUM OF 8 INCHES (0.2 METERS) FROM ANY NEARBY OBJECTS OR SURFACES.  
FIXTURE SHOULD BE PLACED A MINIMUM OF 1.6 FEET (0.5 METERS) FROM ANY FLAMMABLE MATERIALS.  
AMBIENT OPERATING TEMPERATURE RANGE IS -40°F TO 113°F (-40°C TO 45°C)**



# SAFETY GUIDELINES

## **CAUTION**

### **HIGH INTENSITY ULTRAVIOLET LIGHT**



**AVOID DIRECT EYE & SKIN EXPOSURE.  
WEAR PROPER EYE & SKIN PROTECTION.  
SEE MANUAL FOR SAFETY INSTRUCTIONS.**

**RISK GROUP 3 - RISK OF EXPOSURE TO ULTRAVIOLET UV RADIATION! FIXTURE EMITS HIGH INTENSITY WAVELENGTH OF ULTRAVIOLET UV LIGHT FROM THE UV COLOR FILTER. WEAR PROPER EYE AND SKIN PROTECTION. AVOID PROLONGED PERIODS OF EXPOSURE TO UV COLOR FILTER. AVOID WEARING WHITE COLOR CLOTHING AND/OR USING UV PAINTS ON SKIN. AVOID DIRECT EYE AND/OR SKIN EXPOSURE AT DISTANCES LESS THAN 10 feet (3m). DO NOT OPERATE FIXTURE WITH DAMAGED/MISSING EXTERNAL COVERS. DO NOT LOOK DIRECTLY INTO THE UV LIGHT AND/OR VIEW UV LIGHT DIRECTLY WITH OPTICAL INSTRUMENTS THAT MAY CONCENTRATE THE LIGHT/RADIATION OUTPUT.**

**INDIVIDUALS SUFFERING FROM A RANGE OF EYE CONDITIONS, SUNLIGHT EXPOSURE DISORDERS, OR INDIVIDUALS USING PHOTSENSITIVE MEDICATION, MAY RECEIVE DISCOMFORT IF EXPOSED TO THE ULTRAVIOLET UV LIGHT EMITTED FROM THE UV LED.**

- **DO NOT TOUCH** the fixture housing during operation. Turn OFF the power and allow approximately 15 minutes for the fixture to cool down before serving.
- **DO NOT** shake fixture, avoid brute force when installing and/or operating fixture.
- **DO NOT** operate fixture if the power cord is frayed, crimped damaged and/or if any of the power cord connectors are damaged and do not insert into the fixture securely with ease.
- **NEVER** force a power cord connector into the fixture. If the power cord or any of its connectors are damaged, replace it immediately with a new one of similar power rating.
- **DO NOT** block any air ventilation slots.
- All fan and air inlets must remain clean and never blocked.
- Allow approx.6”(15cm) between fixture and other devices or a wall for proper cooling.
- Always disconnect fixture from main power source before performing any type of service and/or cleaning procedure. Only handle the power cord by the plug end, never pull out the plug by tugging the wire portion of the cord.
- During the initial operation of this fixture, a light smoke or smell may emit from the interior of the fixture. This is a normal process and is caused by excess paint in the interior of the casing burning off from the heat associated with the lamp and will decrease gradually over time.
- Consistent operational breaks will ensure the fixture will function properly for many years.
- **ONLY** use the original packaging and materials to transport the fixture in for service.

# OVERVIEW

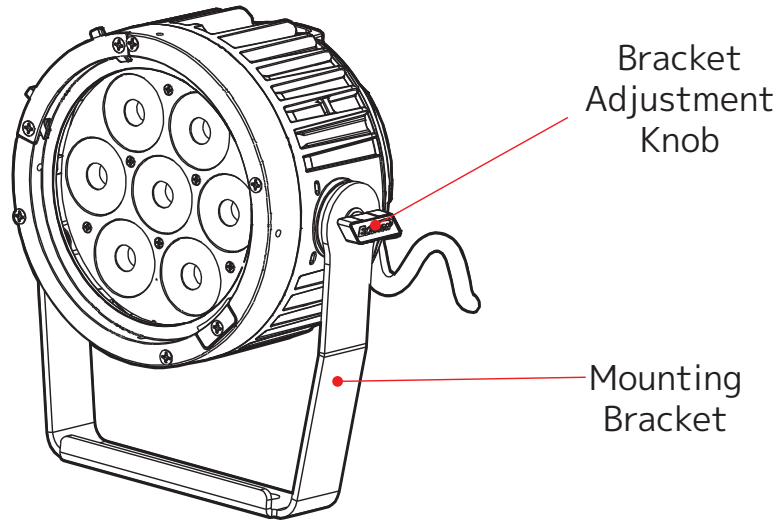

**With 2-wire plate**

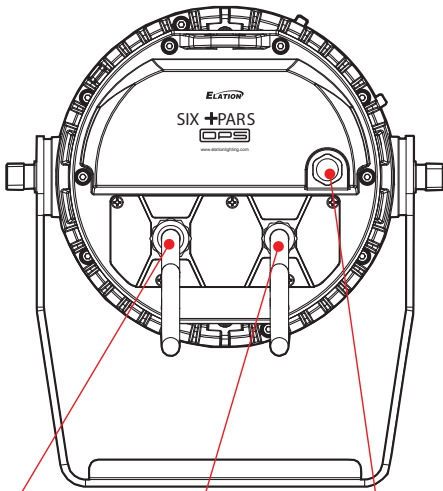

Power Input Cable

DMX In & Out Cable

Air Valve

**With 4-wire plate**

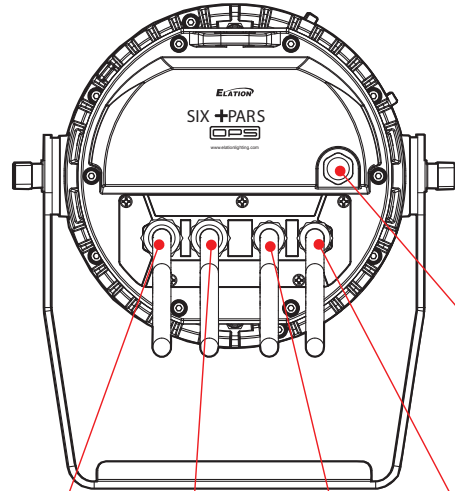

Power Input Cable

Power Output Cable

DMX Output Cable

DMX Input Cable

Air Valve

# TORQUE SETTINGS FOR SCREWS

IN ORDER TO MAINTAIN THE IP65 RATING ON THE LIGHTING FIXTURES, ALL SCREWS MUST BE TIGHTENED TO THE FOLLOWING TORQUE SPECIFICATION USING A TORQUE DRIVER.

Refer to the table and diagram below for torque specifications.

TORQUE DRIVERS (Recommended): UTICA TS-30 (shown)

ALTERNATE DRIVERS:

- Proto J6107A
- Wiha 28887



**CAUTION! DO NOT OVER TORQUE SCREWS, AS THIS CAN CAUSE LEAKAGE ISSUES!**

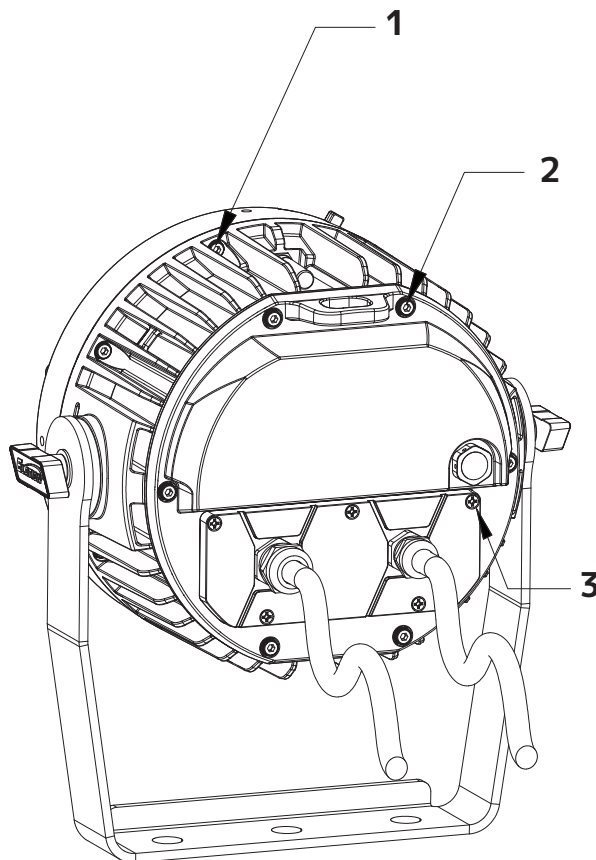

NO.	LOCATION	QUANTITY	TORQUE
1	Front Cover	6	11.3 ± 0.4 lb-in (13.0 ± 0.5 kg-cm)
2	Back Cover	6	11.3 ± 0.4 lb-in (13.0 ± 0.5 kg-cm)
3	Wire Plate (M3 Screws)	5	10.4 ± 0.4 lb-in (12.0 ± 0.5 kg-cm)

# IP TEST PARAMETERS

Following any repair or maintenance procedure that requires disassembly of the fixture, use Elation’s IP Tester to confirm the IP integrity of the fixture. The air valve is located on the same side as the Power Out and DMX Out ports, as shown in the diagram below. Please contact Elation Service for information regarding the Elation IP Tester, or visit the product information page online at: <https://www.elationlighting.com/ip-tester>

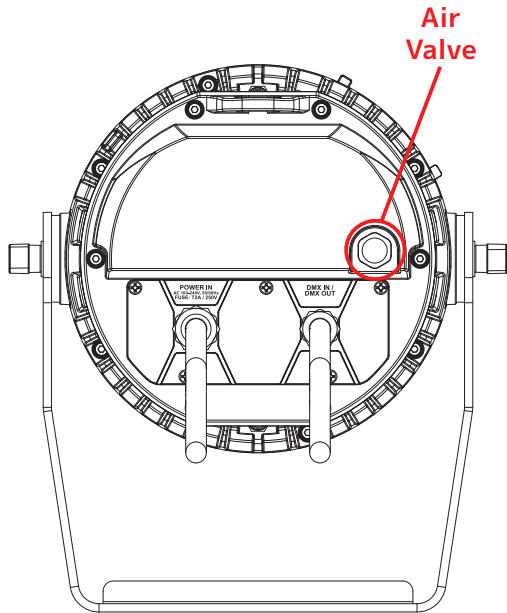

**CAUTION! THE USE OF PROTECTIVE GLOVES AND SAFETY GOGGLES IS STRONGLY RECOMMENDED WHILE PERFORMING THE IP PRESSURE TEST! AVOID PLACING YOUR FACE, EYES, HANDS, ETC IN PROXIMITY TO THE LENS OF THE FIXTURE WHILE PERFORMING THE TEST!**

**DE-HUMIDIFICATION:** IP65 fixtures operating in high-humidity environments may experience residual fogging or condensation. Such fogging will not affect the fixture, and can be removed using the following procedure: position the unit with the air valve pointing upwards, then open the air valve and run the unit for 1-2 hours after reaching operating temperature. Then, while the fixture is still hot, re-install the air valve and allow the unit to cool down. Please note: this procedure should be performed in a dry, climate-controlled environment. Avoid additional fogging by drying the fixture completely before placing into a road case.



IP PRESSURE TESTING PARAMETERS					
Low Pressure Limit	High Pressure Limit	Inflation Time	Balance Time	Inspection Time	Max Leakage
20.0 KPa	23.0 KPa	30s	15s	15s	100 Pa

# INSTALLATION GUIDELINES



## **FLAMMABLE MATERIAL WARNING**

Keep fixture minimum 1.6 feet (0.5m) away from flammable materials and/or pyrotechnics.



## **ELECTRICAL CONNECTIONS**

A qualified electrician should be used for all electrical connections and/or installations.



## **MINIMUM DISTANCE TO OBJECTS/SURFACES IS 8 INCHES (0.2 METERS)**



**AMBIENT OPERATIONAL TEMPERATURE RANGE IS -40°F TO 113°F (-40°C TO 45°C)**



## **DO NOT INSTALL THE FIXTURE IF YOU ARE NOT QUALIFIED TO DO SO!**

Fixture **MUST** be installed following all local, national, and country commercial electrical and construction codes and regulations.

Before rigging/mounting a single fixture or multiple fixtures to any metal truss/structure or placing the fixture(s) on any surface, a professional equipment installer **MUST** be consulted to determine if the metal truss/structure or surface is properly certified to safely hold the combined weight of the fixture(s), clamps, cables, and accessories.

Fixture(s) should be installed in areas outside walking paths, seating areas, or away from areas where unauthorized personnel might reach the fixture by hand.

**NEVER** stand directly below the fixture(s) when rigging, removing, or servicing.

Overhead fixture installation must always be secured with a secondary safety attachment, such as an appropriately rated safety cable.

Allow approximately 15 minutes for the fixture to cool down before serving.

# INSTALLATION GUIDELINES

## CLAMP INSTALLATION

This device features a mounting clamp attachment point built into the mounting bracket. To install, align the hole on the mounting clamp with the central hole in the mounting bracket, then insert a bolt of the appropriate rating through the hole and secure in place with a matching nut. Attach a safety cable of the appropriate rating to the designated attachment point located on the rear face of the fixture near the wire plate. Please note that the spacing of the holes on the mounting bracket has been designed to match the Sixpar 200 and Sixpar 300 fixtures, allowing users to easily swap between these fixtures with minimal impact to the installation hardware.

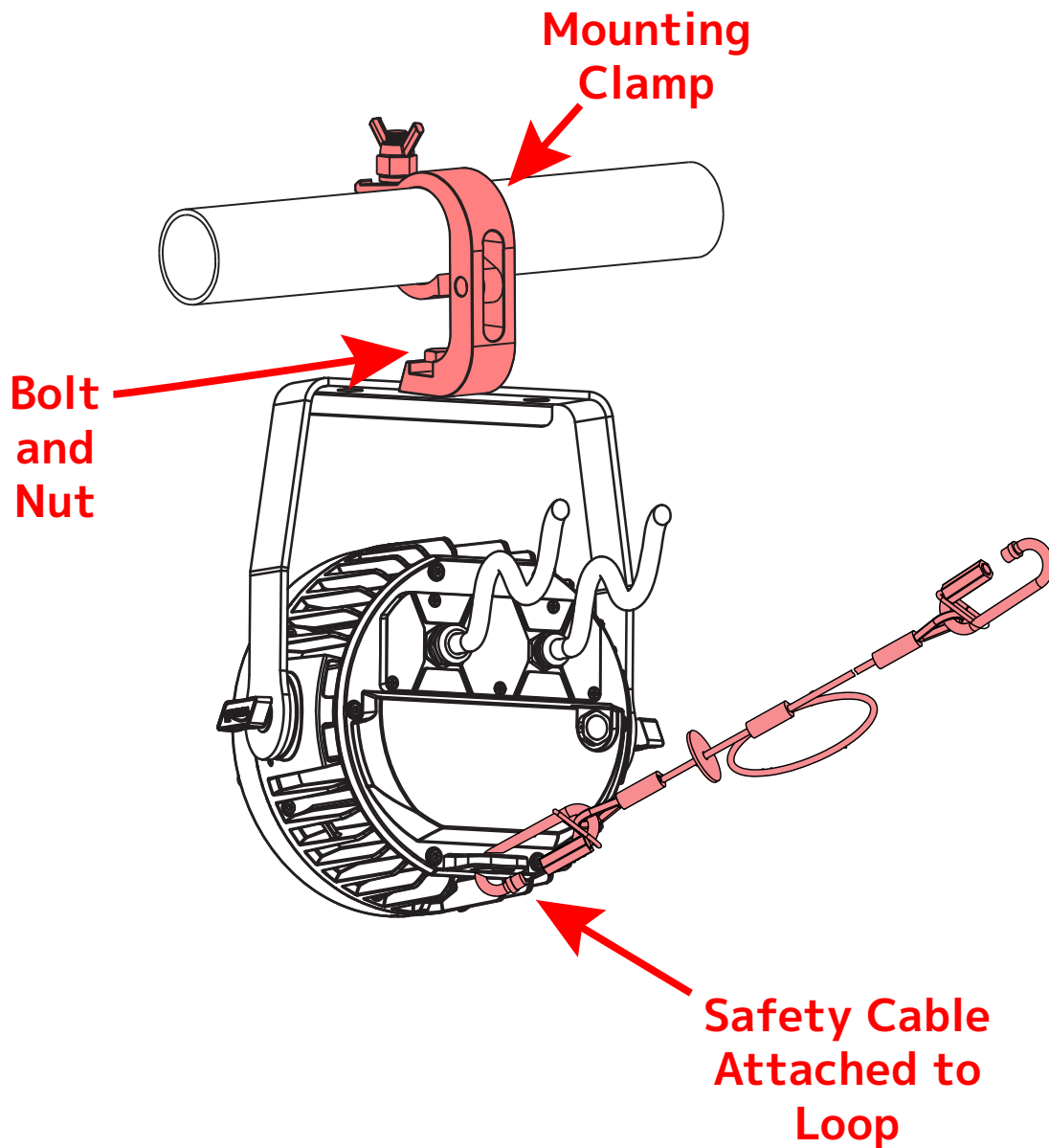

**SAFETY CABLE**  
ALWAYS ATTACH AN APPROPRIATELY RATED SAFETY CABLE WHENEVER INSTALLING THIS FIXTURE IN A SUSPENDED ENVIRONMENT TO ENSURE THE FIXTURE WILL NOT FALL IF THE CLAMP FAILS.



# INSTALLATION GUIDELINES

## FIXTURE INSTALLATION

The Elation SIX+ PAR 5 is fully operational in three different mounting positions, hanging upside-down, mounted sideways on trussing, or set on a flat level surface. Be sure this fixture is kept at least 0.2m (7.9in.) away from any flammable materials (decoration etc.). Always use and install the supplied safety cable as a safety measure to prevent accidental damage and/or injury in the event the clamp fails. Never use the carrying handles for secondary attachment.

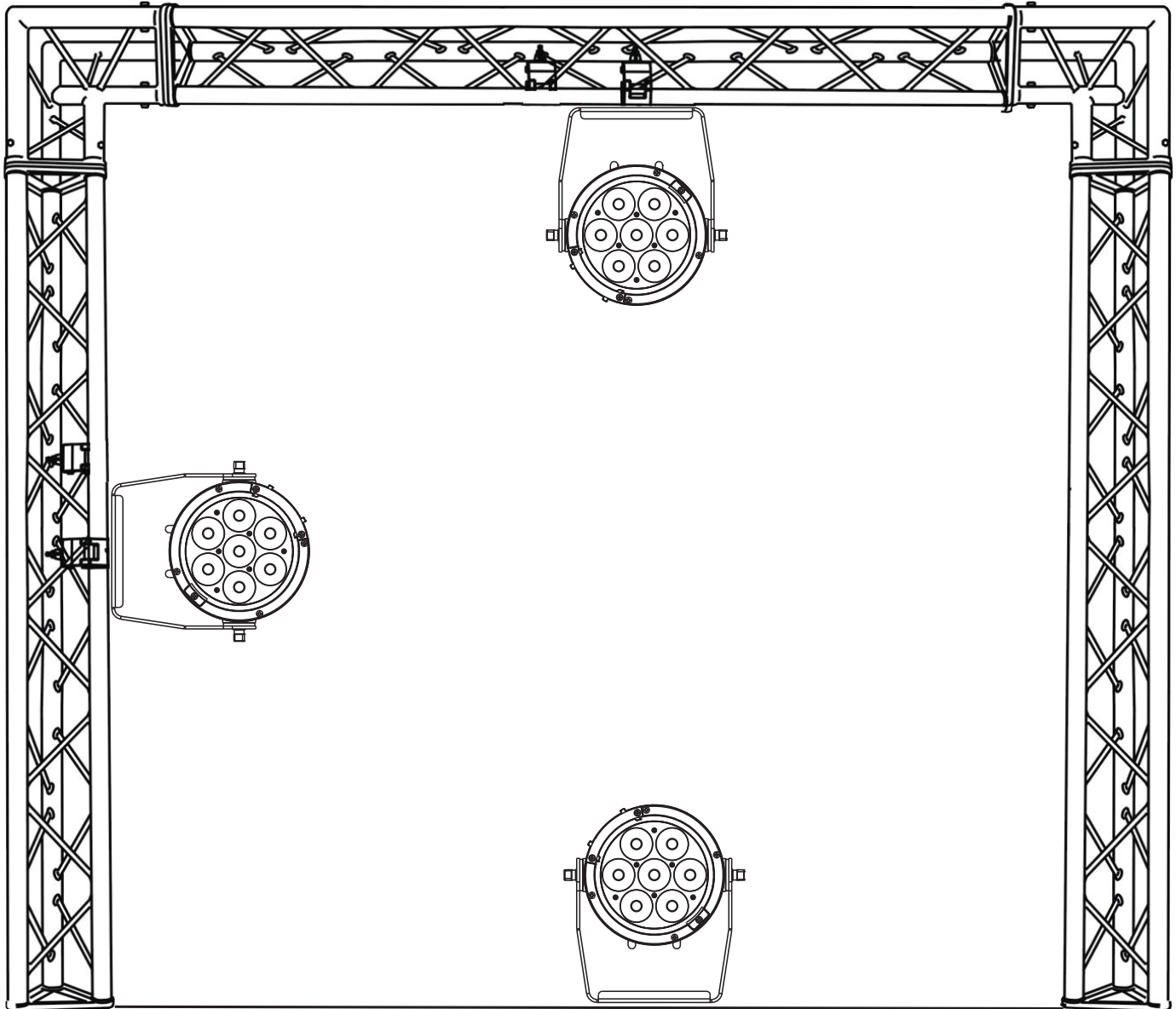

**FALLING FIXTURES CAN CAUSE SEVERE INJURY OR SERIOUS EQUIPMENT DAMAGE! FOR THIS REASON, FIXTURES SHOULD BE INSTALLED AND INSPECTED ONLY BY QUALIFIED PERSONNEL. DO NOT INSTALL THE UNIT IF YOU LACK THE QUALIFICATIONS TO DO SO, OR IF YOU HAVE DOUBTS ABOUT THE SAFETY AND SECURITY OF THE INSTALLATION SETUP OR LOCATION!**



**ALWAYS ATTACH A SAFETY CABLE WHENEVER INSTALLING THIS FIXTURE IN A SUSPENDED ENVIRONMENT TO ENSURE THE FIXTURE WILL NOT FALL IF THE CLAMP FAILS.**



# INSTALLATION GUIDELINES

## POTENTIAL INTERNAL FIXTURE DAMAGE FROM EXTERNAL SOURCES OF LIGHT BEAMS

External sources of light beams from direct sunlight, lighting moving head fixtures, and lasers, which are focused directly towards the exterior housing and/or penetrate the front lens opening of ELATION lighting fixtures, can cause severe internal damage including burning to optics, dichroic color filters, glass and metal gobos, prisms, animation wheels, frost filters, iris, shutters, motors, belts, wiring, discharge lamps, and LEDs.

This issue is not specific only to ELATION lighting fixtures, it is a common issue with lighting fixtures from all manufacturers. Although there is no true way to fully prevent this issue from happening, the guidelines below can prevent any potential damage from occurring if followed. Contact ELATION Service for more details.

**DO NOT EXPOSE THE FIXTURE AND/OR FRONT LENS OPENING TO LIGHT BEAMS FROM DIRECT SUNLIGHT, OTHER FIXTURES, OR LASERS UNDER ANY CIRCUMSTANCES. PLEASE NOTE THAT THIS INCLUDES EXTENDED PERIODS OF NON-USE, AS DAMAGE CAN OCCUR EVEN WHEN THE FIXTURE IS OFF. NEVER FOCUS A LIGHT BEAM FROM ONE LIGHTING FIXTURE DIRECTLY TOWARDS ANOTHER.**

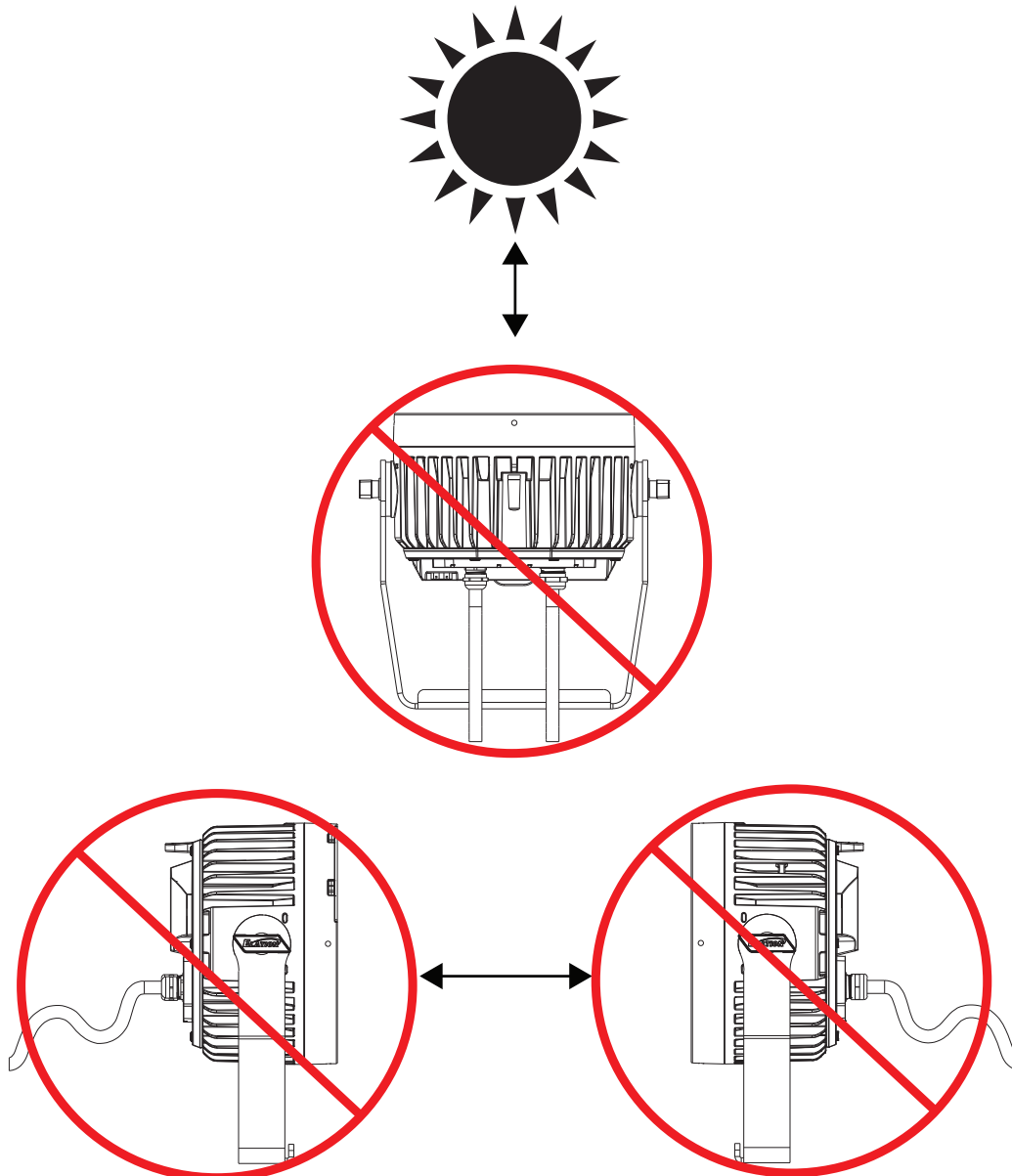

# ACCESSORY INSTALLATION - FROST LENS

1. Slide lock levers inward to retract the locking tabs.

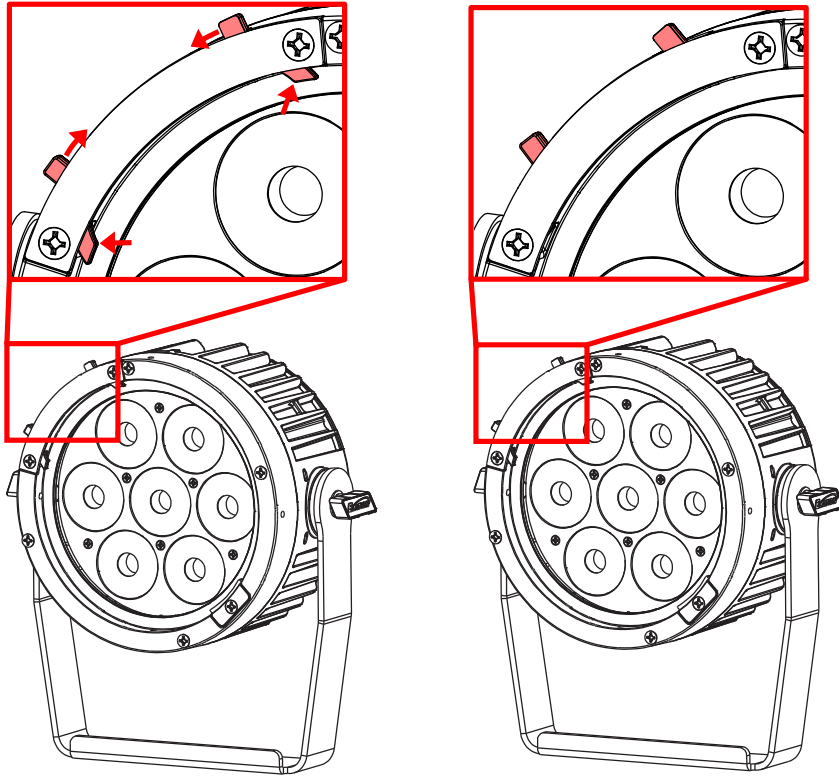

2. Install the Frost Lens by angling the bezel groove of the Frost Lens into the tab and levering it into place.

Frost Lens  
Bezel Groove

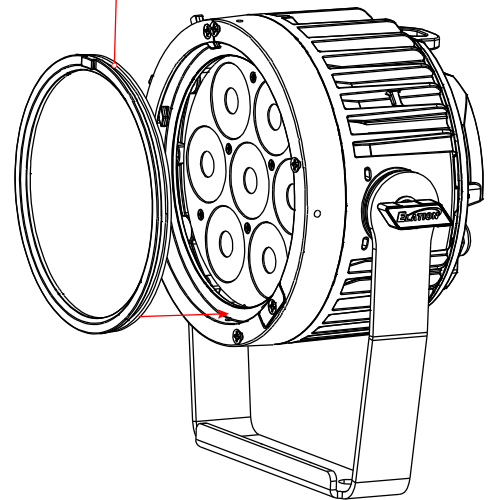

3. With the Frost Lens installed, slide levers outward to lock it in place.

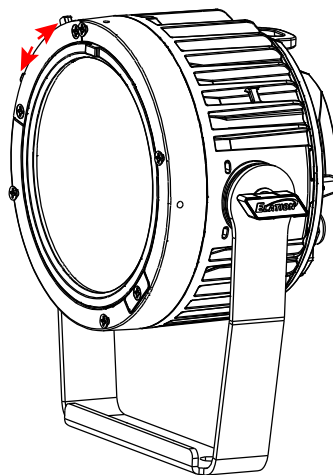

# ACCESSORY INSTALLATION - GEL FRAME

1. Align the 4x holes on the Holder with the face of the fixture, and secure it with 4x philips head screws

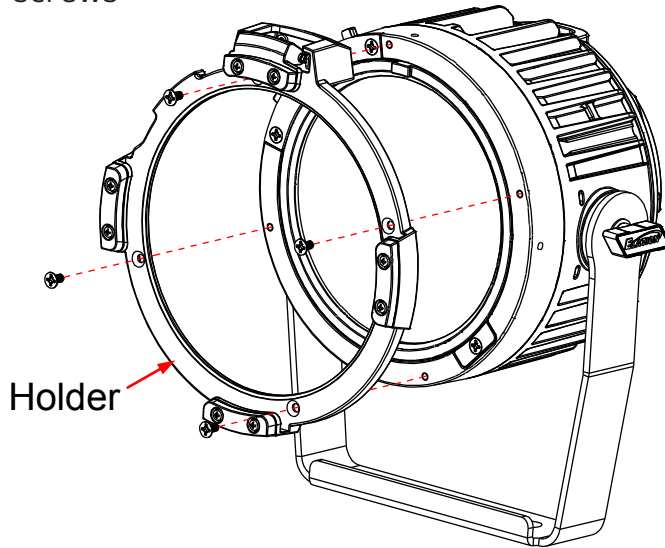

2. Flip up the retaining clip located near the top of the Holder.

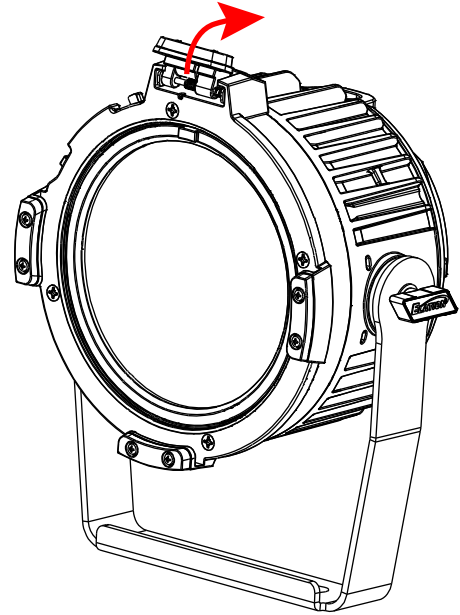

3. Slide the Gel Frame into place. Then close the latch.

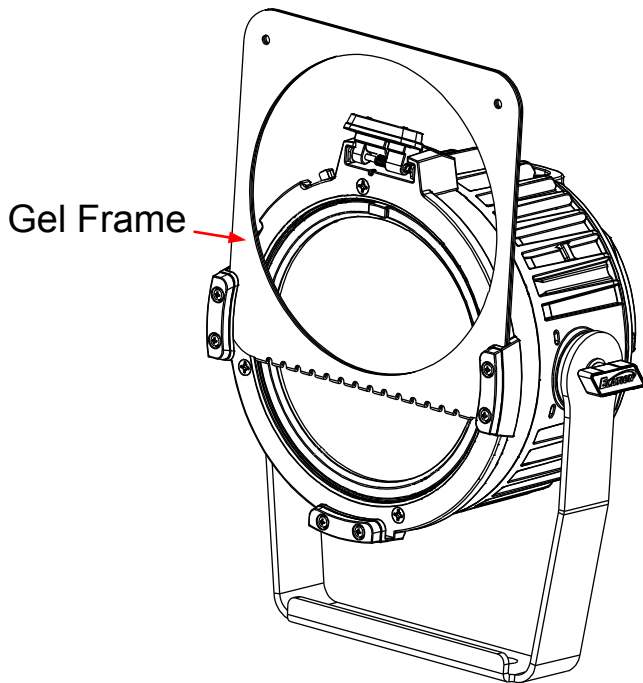

4. Return the retaining clip to the original position.

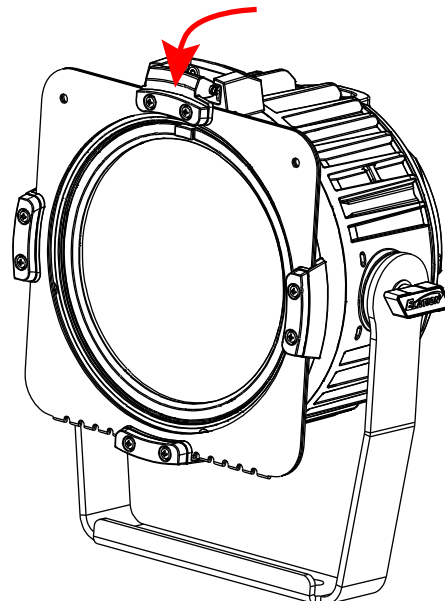

# ACCESSORY INSTALLATION - BARNDOOR

1. Flip open the retaining clip located near the top of the lens.

2. Slide the barndoor into place in front of the Gel Frame.

Gel Frame

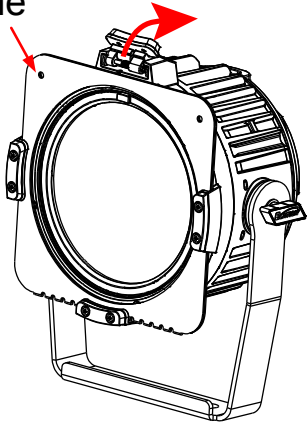

Barndoor

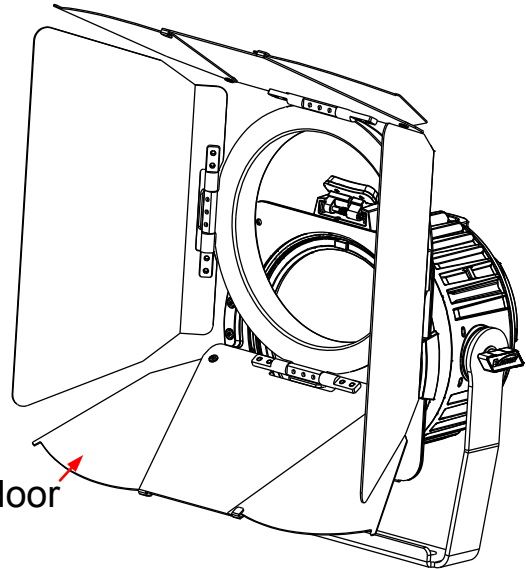

3. Return the retaining clip to the original position to lock the barndoor in place.

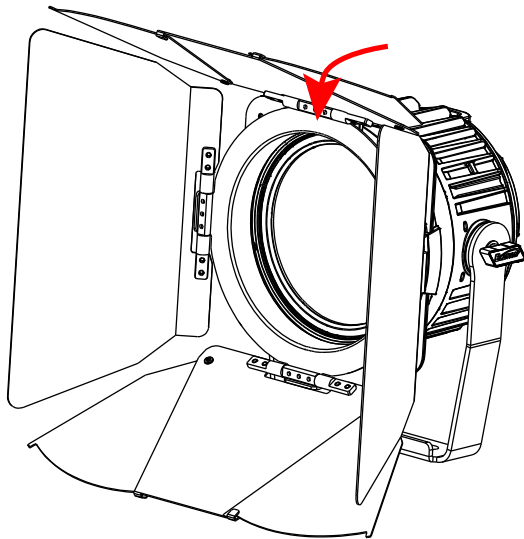

# REMOTE DEVICE MANAGEMENT (RDM)

**NOTE: In order for RDM to work properly, RDM enabled equipment must be used throughout the entire system, including DMX data splitters and wireless systems.**

Remote Device Management (RDM) is a protocol that sits on top of the DMX512 data standard for lighting, and allows the DMX systems of the fixtures to be modified and monitored remotely. This protocol is ideal for instances in which a unit is installed in a location that is not easily accessible.

With RDM, the DMX512 system becomes bi-directional, allowing a compatible RDM enabled controller to send out a signal to devices on the wire, as well as allowing the fixture to respond (known as a GET command). The controller can then use its SET command to modify settings that would typically have to be changed or viewed directly via the unit's display screen, including the DMX Address, DMX Channel Mode, and Temperature Sensors.

## FIXTURE RDM INFORMATION:

Device ID	Device Model ID	RDM Code	Personality ID
005B	91	22A6	1Ch Dimmer, 3Ch RGB, 9Ch RGB Extended, 6Ch Color, 9Ch Color & Dimmer, 11Ch CMY, 14Ch CMY Extended, 14Ch Standard, 20Ch Extended, SixPar Emulation, SixPar 6 Channel, SixPar 7 Channel, SixPar 8 Channel, SixPar 12 Channel

Please be aware that **not all RDM devices support all RDM features**, and therefore it is important to check beforehand to ensure that the equipment that you are considering includes all of the features that you require.

The following parameters are accessible in RDM on this device:

0x00F0	DMX Start Address	0x800B	Set Dim Curves
0x00E0	DMX Personality	0x800C	Set Freq
0x8001	DMX No DMX	0x800D	Set LED Power
0x8002	DMX Protocol	0x800E	Reset Defaults
0x8003	Aria Enable	0x800F	Time Current
0x8004	Aria Freq	0x8010	Time Total
0x8005	Aria GHz	0x8011	Time Last
0x8006	Aria Gig	0x8012	Temp Current
0x8007	Aria Mesh	0x8013	Temp Max
0x8008	Aria Bluetooth	0x8014	Info UID
0x8009	Set Self Test	0x8015	Info Error
0x800A	Set Dim Mode	0x8016	Service Rst Error

# DIMMER MODES & CURVES

DIMMER

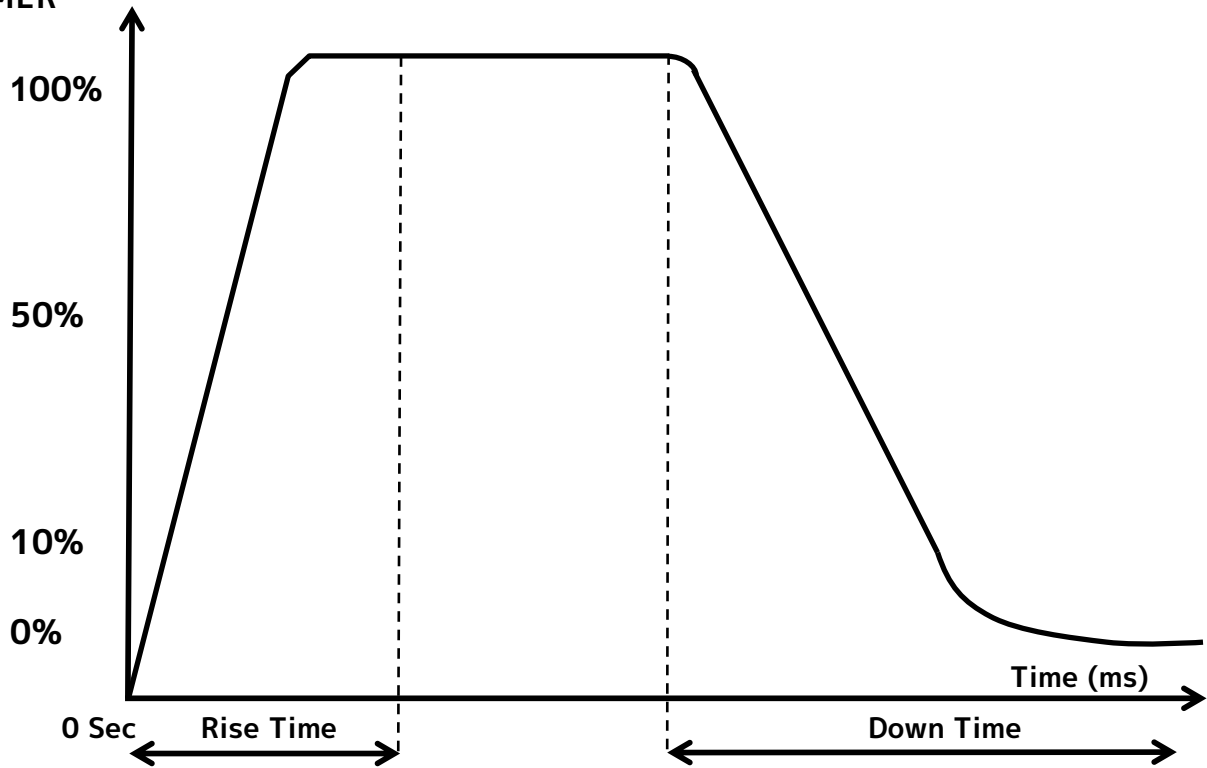

Dimming Curve Ramp Effect	0 sec Fade Time		1 sec Fade Time	
	Rise Time (ms)	Down Time (ms)	Rise Time (ms)	Down Time (ms)
Standard (default)	0	0	0	0
Stage	780	1100	1540	1660
TV	1180	1520	1860	1940
Architectural	1380	1730	2040	2120
Theatre	1580	1940	2230	2280
Stage 2	0	1100	0	1660

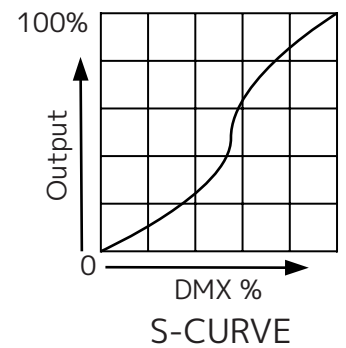
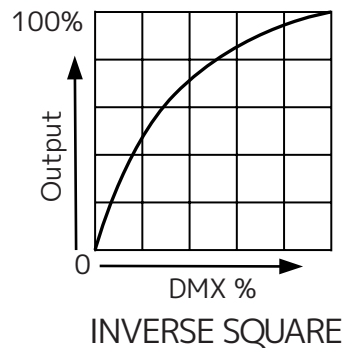
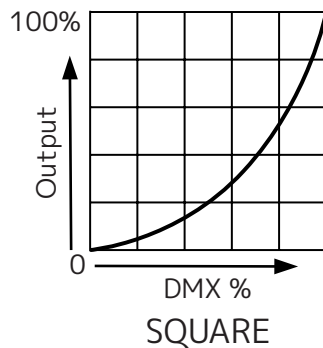
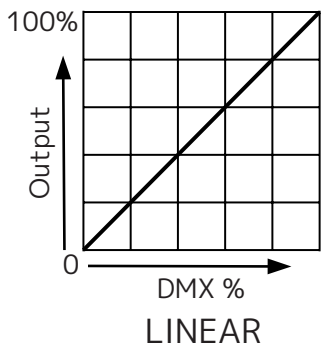

# DMX TRAITS

Dim. 1CH	RGB 3CH	RGB Ext. 9CH	Color 6CH	Color & Dim. 9CH	CMY 11CH	CMY Ext. 14CH	Std. 14CH	Ext. 20CH	DMX Values	Function	Snap	Default Value
1		1		1	1	1	1	1	0-255	<b>Dimmer</b> Intensity 0 → 100%		0
		2		2	2	2	2	2	0-255	<b>Dimmer Fine</b> Fine Intensity Control		0
		3		3	3	3	3	3	0-31	<b>Shutter/Strobe</b> Shutter closed		50
									32-63	No function (shutter open)		
									64-95	Strobe effect slow to fast		
									96-127	No function (shutter open)		
									128-159	Pulse-effect in sequences		
									160-191	No function (shutter open)		
									192-223	Random strobe effect slow to fast		
									224-255	No function (shutter open)		
	1	4	1	4			4	4	0-255	<b>Red</b> 0 → 100%		0
		5						5	0-255	<b>Red Fine</b> Fine Adjustment		0
	2	6	2	5			5	6	0-255	<b>Green</b> 0 → 100%		0
		7						7	0-255	<b>Green Fine</b> Fine Adjustment		0
	3	8	3	6			6	8	0-255	<b>Blue</b> 0 → 100%		0
		9						9	0-255	<b>Blue Fine</b> Fine Adjustment		0
			4	7			7	10	0-255	<b>Lime</b> 0 → 100%		0
								11	0-255	<b>Lime Fine</b> Fine Adjustment		0
			5	8			8	12	0-255	<b>Amber</b> 0 → 100%		0
								13	0-255	<b>Amber Fine</b> Fine Adjustment		0
			6	9			9	14	0-255	<b>UV</b> 0 → 100%		0
								15	0-255	<b>UV Fine</b> Fine Adjustment		0
					4	4			0-255	<b>Cyan</b> 0 → 100%		0
						5			0-255	<b>Cyan Fine</b> Fine Adjustment		0
					5	6			0-255	<b>Magenta</b> 0 → 100%		0
						7			0-255	<b>Magenta Fine</b> Fine Adjustment		0
					6	8			0-255	<b>Yellow</b> 0 → 100%		0
						9			0-255	<b>Yellow Fine</b> Fine Adjustment		0
					7	10	10	16	0-23	<b>Variable CCT</b> Open		0
									24-85	2400K → 8500K (See Sheet)		
									86-255	8500K		
					8	11	11	17	0	<b>CCT Cross Fade</b> Pure CCT output	X	0
									1-254	Fade from pure CCT output to pure color output		
									255	Pure color output		



# DMX TRAITS

Dim. 1CH	RGB 3CH	RGB Ext. 9CH	Color 6CH	Color & Dim. 9CH	CMY 11CH	CMY Ext. 14CH	Std. 14CH	Ext. 20CH	DMX Values	Function	Snap	Default Value
										<b>Color</b>		
									0	Open		
									1-179	Virtual Swatch Book (See Table)		
										<b>Color Scroll</b>		
									180-201	Clockwise Fast → Slow		
									202-207	Stop		
					9	12	12	18	208-229	Counter-clockwise Slow → Fast		0
									230-234	Open		
										<b>Random Slots</b>		
									235-239	Fast		
									240-244	Medium		
									245-249	Slow		
									250-255	Open		
										<b>Dim Modes</b>		
									0-20	Standard		
									21-40	Stage		
									41-60	TV		
									61-80	Architectural		
									81-100	Theatre		
									101-120	Stage 2		
										<b>Dimmer Delay Time</b>		
									121	0s		
									122	0.1s		
									123	0.2s		
									124	0.3s		
									125	0.4s		
									126	0.5s		
					10	13	13	19	127	0.6s	X	0
									128	0.7s		
									129	0.8s		
									130	0.9s		
									131	1.0s		
									132	1.5s		
									133	2.0s		
									134	3.0s		
									135	4.0s		
									136	5.0s		
									137	6.0s		
									138	7.0s		
									139	8.0s		
									140	9.0s		
									141	10s		
									141-255	Idle		

# DMX TRAITS

Dim. 1CH	RGB 3CH	RGB Ext. 9CH	Color 6CH	Color & Dim. 9CH	CMY 11CH	CMY Ext. 14CH	Std. 14CH	Ext. 20CH	DMX Values	Function	Snap	Default Value
										<b>Control</b>		
									0-84	Idle		
									85-89	Bluetooth On		
									90-94	Bluetooth Off (Default)		
									95-99	Idle		
										<b>Refresh Rate (Hz)</b>		
									100	900		
									101	910		
									102	920		
									103	930		
									104	940		
									105	950		
									106	960		
									107	970		
									108	980		
									109	990		
									110	1000		
									111	1010		
									112	1020		
									113	1030		
									114	1040		
					11	14	14	20	115	1050	X	0
									116	1060		
									117	1070		
									118	1080		
									119	1090		
									120	1100		
									121	1110		
									122	1120		
									123	1130		
									124	1140		
									125	1150		
									126	1160		
									127	1170		
									128	1180		
									129	1190		
									130	1200		
									131	1210		
									132	1220		
									133	1230		
									134	1240		
									135	1250		
									136	1260		

# DMX TRAITS

Dim. 1CH	RGB 3CH	RGB Ext. 9CH	Color 6CH	Color & Dim. 9CH	CMY 11CH	CMY Ext. 14CH	Std. 14CH	Ext. 20CH	DMX Values	Function	Snap	Default Value
									137	1270		
									138	1280		
									139	1290		
									140	1300		
									141	1310		
									142	1320		
									143	1330		
									144	1340		
									145	1350		
									146	1360		
									147	1370		
									148	1380		
									149	1390		
									150	1400		
									151	1410		
									152	1420		
									153	1430		
									154	1440		
									155	1450		
					11	14	14	20	156	1460	X	0
									157	1470		
									158	1480		
									159	1490		
									160	1500		
									161	2500		
									162	4000		
									163	5000		
									164	6000		
									165	10000		
									166	15000		
									167	20000		
									168	25000		
									169-200	Idle		
										<b>Dimmer Curves</b>		
									201-210	Dimmer Curve: Linear (Default)		
									211-220	Dimmer Curve: Square		
									221-230	Dimmer Curve: Inverse Square		
									231-240	Dimmer Curve: S-Curve		
									241-255	Idle		

# EMULATION DMX TRAITS

6 ch	7 CH	8 CH	12 CH	Value	Function	Snap	Default Value
1	1	1	1	0-255	<b>Red</b> 0 → 100%		0
2	2	2	2	0-255	<b>Green</b> 0 → 100%		0
3	3	3	3	0-255	<b>Blue</b> 0 → 100%		0
4	4	4	4	0-255	<b>White</b> 0 → 100%		0
5	5	5	5	0-255	<b>Amber</b> 0 → 100%		0
6	6	6	6	0-255	<b>UV</b> 0 → 100%		0
	7	7	7	0-255	<b>Master Dimmer</b> Intensity 0 → 100%		0
					<b>Shutter/Strobe</b>		
				0-31	Shutter Open		
				32-95	Strobe effect slow to fast		
				96-127	No function (shutter open)		
				128-159	Pulse-effect in sequences		
				160-191	No function (shutter open)		
				192-223	Random strobe effect slow to fast		
				224-255	No function (shutter open)		
					<b>Color Macros</b>		
				0-3	OFF		
				4-7	RED		
				8-11	GREEN		
				12-15	BLUE		
				16-19	WHITE		
				20-23	AMBER		
				24-27	UV		
				28-31	RED + GREEN		
				32-35	RED + BLUE		
				36-39	RED + WHITE		
				40-43	RED + AMBER		
				44-47	RED + UV		
				48-51	GREEN + BLUE		
				52-55	GREEN + WHITE		
			9	56-59	GREEN + AMBER		
				60-63	GREEN + UV	X	0
				64-67	BLUE + WHITE		
				68-71	BLUE + AMBER		
				72-75	BLUE + UV		
				76-79	WHITE + AMBER		
				80-83	WHITE + UV		
				84-87	AMBER + UV		
				88-91	RED + GREEN + BLUE		
				92-95	RED + GREEN + WHITE		
				96-99	RED + GREEN + AMBER		
				100-103	RED + GREEN + UV		
				104-107	RED + BLUE + WHITE		
				108-111	RED + BLUE + AMBER		
				112-115	RED + BLUE + UV		
				116-119	RED + WHITE + AMBER		
				120-123	RED + WHITE + UV		

# EMULATION DMX TRAITS

6 ch	7 CH	8 CH	12 CH	Value	Function	Snap	Default Value
			9	124-127	RED + AMBER + UV	X	0
				128-131	GREEN + BLUE + WHITE		
				132-135	GREEN + BLUE + AMBER		
				136-139	GREEN + BLUE + UV		
				140-143	GREEN + WHITE + AMBER		
				144-147	GREEN + WHITE + UV		
				148-151	GREEN + AMBER + UV		
				152-155	BLUE + WHITE + AMBER		
				156-159	BLUE + WHITE + UV		
				160-163	BLUE + AMBER + UV		
				164-167	WHITE + AMBER + UV		
				168-171	RED + GREEN + BLUE + WHITE		
				172-175	RED + GREEN + BLUE + AMBER		
				176-179	RED + GREEN + BLUE + UV		
				180-183	RED + GREEN + WHITE + AMBER		
				184-187	RED + GREEN + WHITE + UV		
				188-191	RED + GREEN + AMBER + UV		
				192-195	RED + BLUE + WHITE + AMBER		
				196-199	RED + BLUE + WHITE + UV		
				200-203	RED + BLUE + AMBER + UV		
				204-207	RED + WHITE + AMBER + UV		
				208-211	GREEN + BLUE + WHITE + AMBER		
				212-215	GREEN + BLUE + WHITE + UV		
				216-219	GREEN + BLUE + AMBER + UV		
				220-223	GREEN + WHITE + AMBER + UV		
				224-227	BLUE + WHITE + AMBER + UV		
				228-231	RED + GREEN + BLUE + WHITE + AMBER		
				232-235	RED + GREEN + BLUE + WHITE + UV		
				236-239	RED + GREEN + BLUE + AMBER + UV		
				240-243	RED + GREEN + WHITE + AMBER + UV		
				244-247	RED + BLUE + WHITE + AMBER + UV		
				248-251	GREEN + BLUE + WHITE + AMBER + UV		
			252-255	RED + GREEN + BLUE + WHITE + AMBER + UV			
			10	<b>Color Chase Macros</b>		X	0
				0-20	No Function		
				21-40	30 Color Chase		
				41-60	6 Color Chase		
				61-80	Color Fade Chase		
				81-255	No Function		
			11	<b>Color Chase Macro Speed</b>			
				0-255	Color Chase Speed Slow to Fast		
			12	<b>Dimming Modes</b>		X	0
				0-20	Standard		
				21-40	Stage		
				41-60	TV		
				61-80	Architectural		
				81-100	Theatre		
			101-255	No Function			

# COLOR TEMPERATURE

DMX VALUE	COLOR TEMPERATURE (K)	DMX VALUE	COLOR TEMPERATURE (K)
24	2400	63	6300
25	2500	64	6400
26	2600	65	6500
27	2700	66	6600
28	2800	67	6700
29	2900	68	6800
30	3000	69	6900
31	3100	70	7000
32	3200	71	7100
33	3300	72	7200
34	3400	73	7300
35	3500	74	7400
36	3600	75	7500
37	3700	76	7600
38	3800	77	7700
39	3900	78	7800
40	4000	79	7900
41	4100	80	8000
42	4200	81	8100
43	4300	82	8200
44	4400	83	8300
45	4500	84	8400
46	4600	85	8500
47	4700		
48	4800		
49	4900		
50	5000		
51	5100		
52	5200		
53	5300		
54	5400		
55	5500		
56	5600		
57	5700		
58	5800		
59	5900		
60	6000		
61	6100		
62	6200		

# VIRTUAL COLORS

VALUE	FILTER #	COLOR	VALUE	FILTER #	COLOR
1	7	Pale Yellow	31	126	Mauve
2	103	Straw	32	49	Medium Purple
3	151	Gold Tint	33	58	Lavender
4	100	Spring Yellow	34	199	Palace Blue
5	10	Medium Yellow	35	119	Dark Blue
6	101	Yellow	36	132	Medium Blue
7	104	Deep Amber	37	120	Deep Blue
8	15	Deep Straw	38	165	Daylight Blue
9	179	Loving Amber	39	161	Slate Blue
10	21	Gold Amber	40	118	Light Blue
11	105	Orange	41	68	Sky Blue
12	158	Deep Orange	42	143	Pale Navy Blue
13	22	Dark Amber	43	131	Marine Blue
14	778	Millennium Gold	44	115	Peacock Blue
15	135	Deep Golden Amber	45	172	Lagoon Blue
16	24	Scarlet	46	116	Medium Blue Green
17	106	Primary Red	47	90	Dark Yellow Green
18	26	Bright Red	48	139	Primary Green
19	27	Medium Red	49	122	Fern Green
20	19	Fire	50	89	Moss Green
21	157	Pink	51	124	Dark Green
22	36	Medium Pink	52	88	Mint Green
23	111	Dark Pink	53	138	Pale Green
24	128	Bright Pink	54	203	Quarter CT Blue
25	148	Bright Rose	55	202	Half CT Blue
26	332	Special Rose Pink	56	201	FULL CT Blue
27	793	Vanity Fair	57	200	Double CT Blue
28	113	Magenta	58	206	Quarter CT Orange
29	46	Dark Magenta	59	205	Half CT Orange
30	48	Rose Purple	60	204	FULL CT Orange



# SOFTWARE UPDATES



**AN ELATION C-LOADER II CAN ALSO BE USED TO UPDATE THE FIXTURE TO THE LATEST SOFTWARE. To order this device, please contact Elation Support for further details.**

Detailed instructions can be found online at [www.elationlighting.com](http://www.elationlighting.com).

**ELATION SERVICE USA - Monday - Friday 8:00am to 4:30pm PST  
323-582-3322 | Fax 323-832-9142 | support@elationlighting.com**

**ELATION SERVICE EUROPE - Monday - Friday 08:30 to 17:00 CET  
+31 45 546 85 63 | Fax +31 45 546 85 96 | support@elationlighting.eu**

# MAINTENANCE GUIDELINES



**DISCONNECT POWER BEFORE PERFORMING ANY MAINTENANCE!**

## **CLEANING**

Frequent cleaning is recommended to ensure proper function, optimized light output, and an extended life. The frequency of cleaning depends on the environment in which the fixture operates: damp, smoky or particularly dirty environments can cause greater accumulation of dirt on the fixture's optics. Clean periodically with a soft cloth to avoid dirt/debris accumulation.

**NEVER** use alcohol, solvents, or ammonia-based cleaners.

## **MAINTENANCE**

Regular inspections are recommended to insure proper function and extended life. There are no user serviceable parts inside this fixture. Please refer all other service issues to an authorized Elation service technician. Should you need any spare parts, please order genuine parts from an authorized Elation dealer.

Please refer to the following points during routine inspections:

- A detailed electrical check by an approved electrical engineer every three months, to make sure the circuit contacts are in good condition and prevent overheating.
- Be sure all screws and fasteners are securely tightened at all times. Loose screws may fall out during normal operation, resulting in damage or injury as larger parts could fall.
- Check for any deformations on the housing, color lenses, rigging hardware and rigging points (ceiling, suspension, trussing). Deformations in the housing could allow for dust to enter into the fixture. Damaged rigging points or unsecured rigging could cause the fixture to fall and seriously injure a person(s).
- Electric power supply cables must not show any damage, material fatigue or sediments.

# SPECIFICATIONS

## SOURCE

(7) x 20W RGBLA+ UV LEDs  
30,000 Hour Average LED Life\*

\*May vary depending on several factors including but not limited to: Environmental Conditions, Power/Voltage, Usage Patterns (On-Off Cycling), Control and Dimming.

## PHOTOMETRIC DATA

3200 Total Lumen Output  
CRI - 87

## EFFECTS

Electronic Dimmer and Strobe  
Variable 16-bit Dimming Modes and Curves

## COLOR

RGBMA+ UV Color Array  
CMY Emulation  
Variable CCT 2400K - 8500K  
Virtual Gel Swatch Book

## CONTROL / CONNECTIONS

9 DMX Channel Modes (1ch, 3ch, 6ch, 9ch, 9ch, 11ch, 14ch, 14ch, 20ch)  
4 SixPar Emulation DMX Channel Modes (6ch, 7ch, 8ch, 12ch)  
RDM (Remote Device Management)  
Hard Wired (Bare Wire) IP Rated Power and Data Cables Attached

## SIZE / WEIGHT

Length: 7.6" (193mm)  
Width: 9.5" (241mm)  
Vertical Height: 9.1" (230mm)  
Weight: 9.5 lbs (4.3 kg)

## ELECTRICAL / THERMAL

AC 100-240V - 50/60Hz  
100W Max Power Consumption  
5°F to 113°F (-15°C to 45°C)  
BTU/hr (+/- 10%) 341

## INCLUDED ITEMS

Safety Cable

## OPTIONAL ITEMS

7.5" Black Barndoor  
Additional Lenses  
Gel Frame & Holder Kit

# DIMENSION DRAWINGS

Drawings not to scale

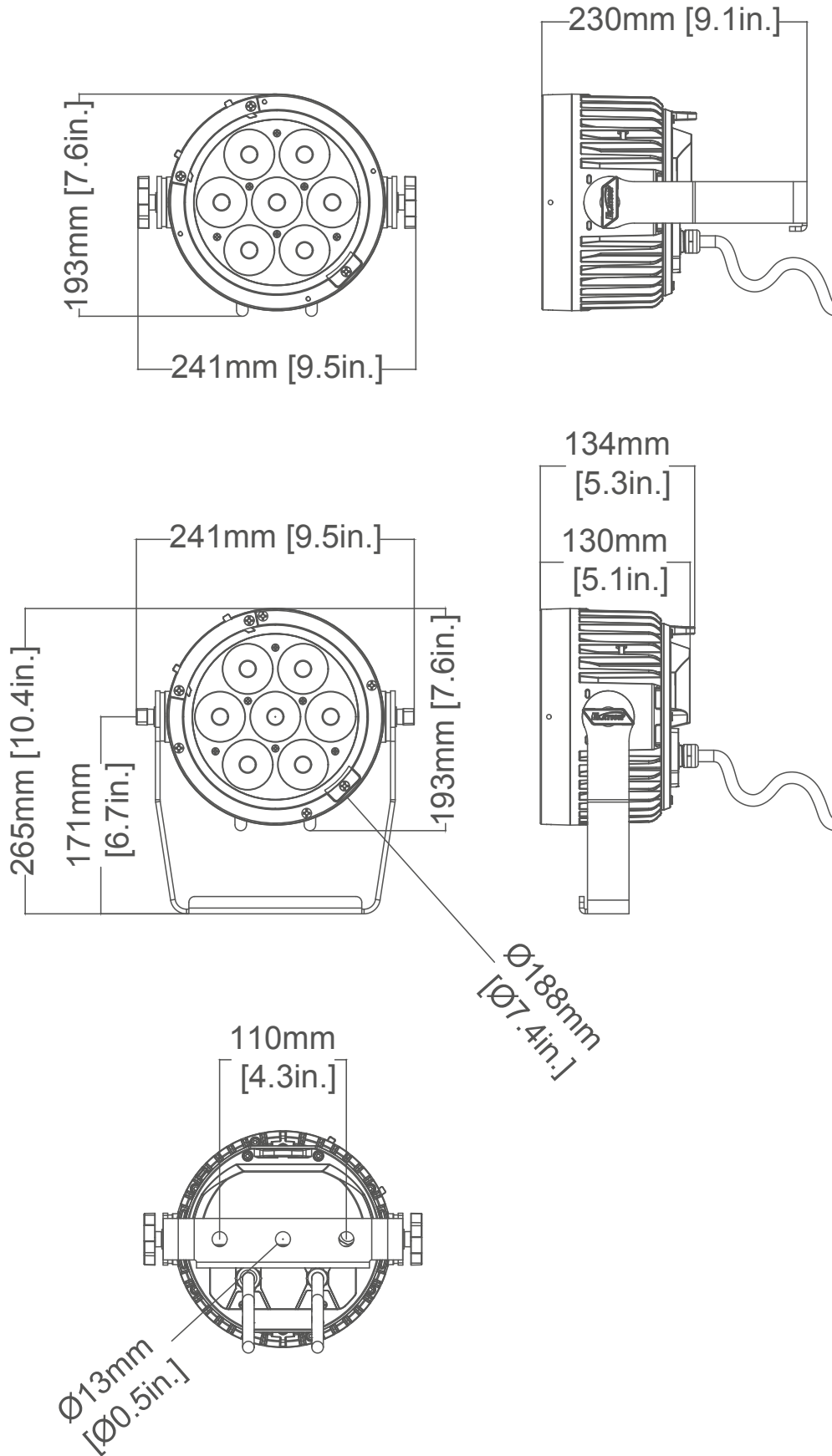

# DIMENSION DRAWINGS

Drawings not to scale

## HOLDER

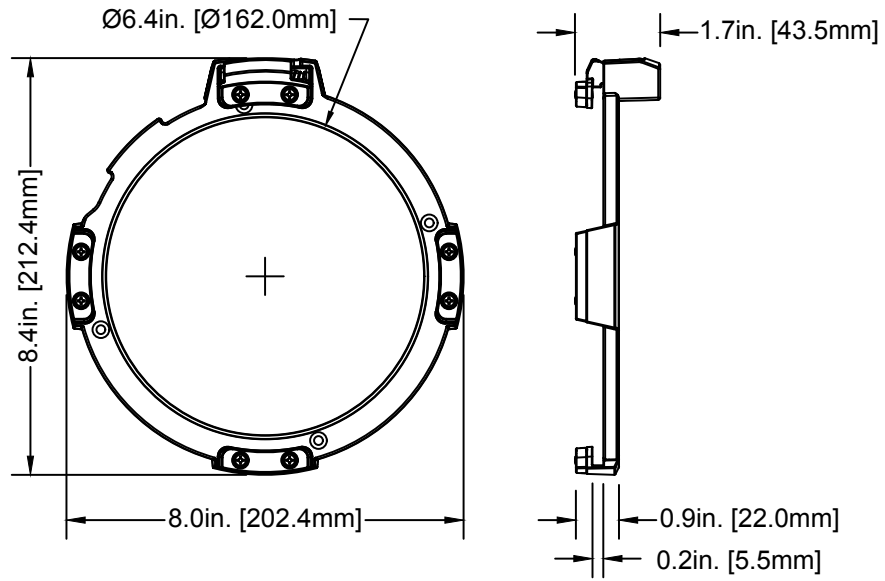

## FROST FILTER

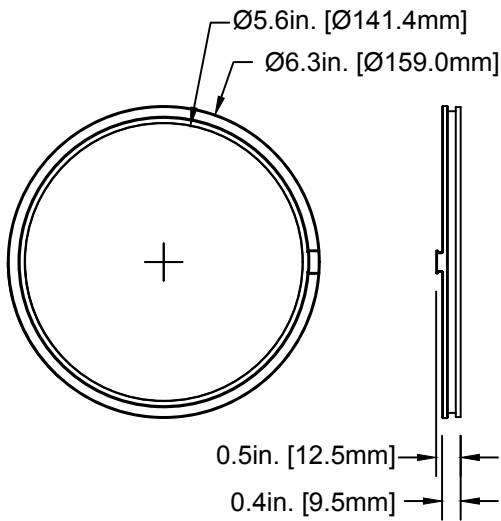

## GEL FRAME

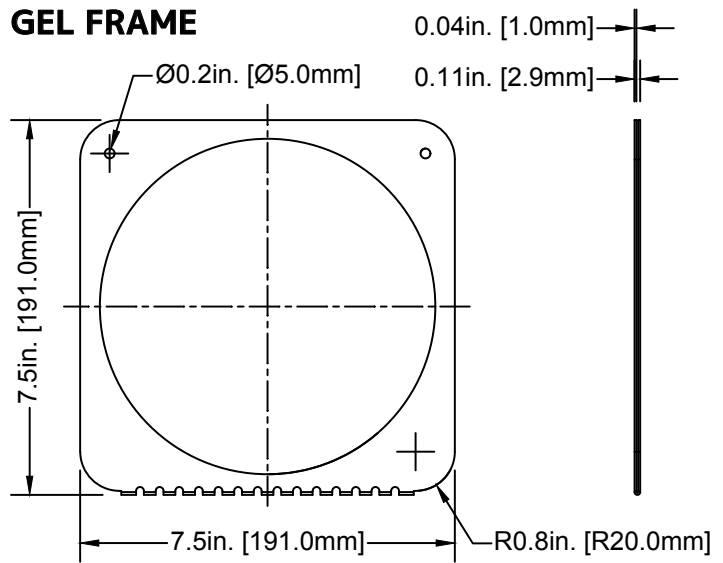

## BARNDOOR

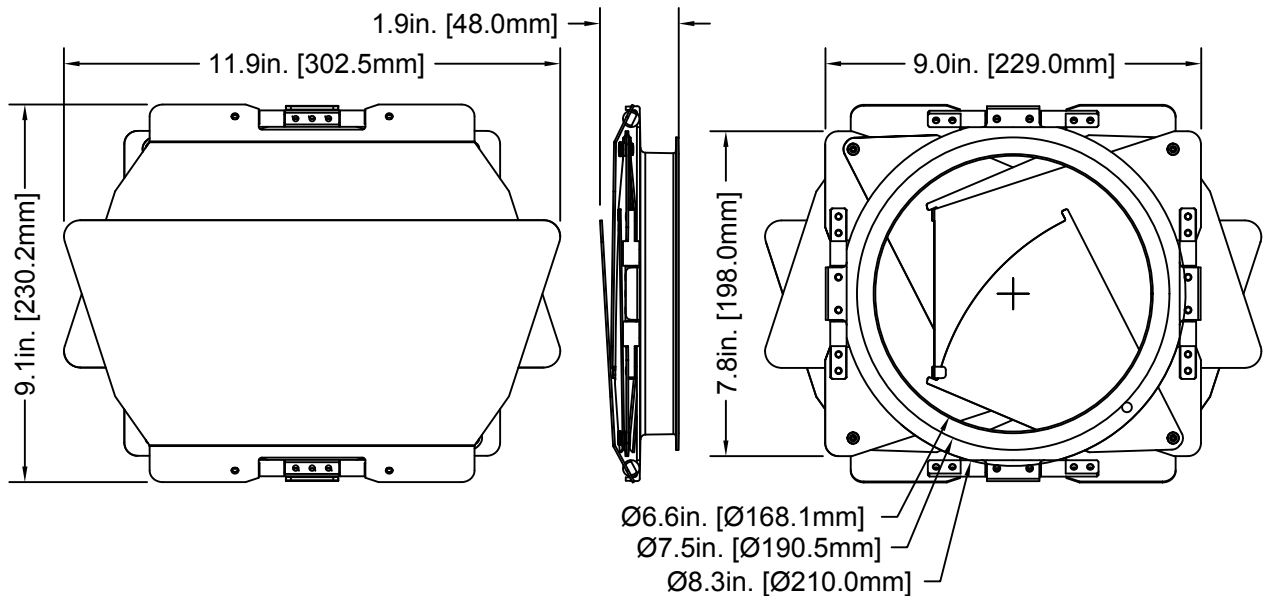

# ORDERING INFORMATION

SKU US/EU		ITEM DESCRIPTION
SIX434	1237000372	SIX+ PAR S OPS
SIX+S WFL	1223200104	60° lens
SIX+S XFL	1223200105	100° Lens
SIX+S L1060	1223200102	10°x60° Lens
SIX+S L140	1223200103	1°x40° Lens
SIX+S GFK	1621000164	Gel Frame Holder & Bumper
KLP959	1236100143	7.5" Barndoor
HWP404	PENDING	4 Wire Hardwire Plate
HWP202	PENDING	2 Wire Hardwire Plate

## ERROR CODES

CODE	ERROR
TEMP	Temperature Error



### FCC STATEMENT

This device complies with Part 15 of the FCC Rules. Operation is subject to the following two conditions: (1) this device may not cause harmful interference, and (2) this device must accept any interference received, including interference that may cause undesired operation.

### FCC RADIO FREQUENCY INTERFERENCE WARNINGS & INSTRUCTIONS

This product has been tested and found to comply with the limits as per Part 15 of the FCC Rules. These limits are designed to provide reasonable protection against harmful interference in a residential installation. This device uses and can radiate radio frequency energy and, if not installed and used in accordance with the included instructions, may cause harmful interference to radio communications. However, there is no guarantee that interference will not occur in a particular installation. If this device does cause harmful interference to radio or television reception, which can be determined by turning the device off and on, the user is encouraged to try to correct the interference by one or more of the following methods:

- Reorient or relocate the device.
- Increase the separation between the device and the receiver.
- Connect the device to an electrical outlet on a circuit different from which the radio receiver is connected.
- Consult the dealer or an experienced radio/TV technician for help.

### Energy Saving Matters (EuP 2009/125/EC)

Saving electric energy is a key to help protecting the environment. Please turn off all electrical products when they are not in use. To avoid power consumption in idle mode, disconnect all electrical equipment from power when not in use. Thank you!

