

ELATION®

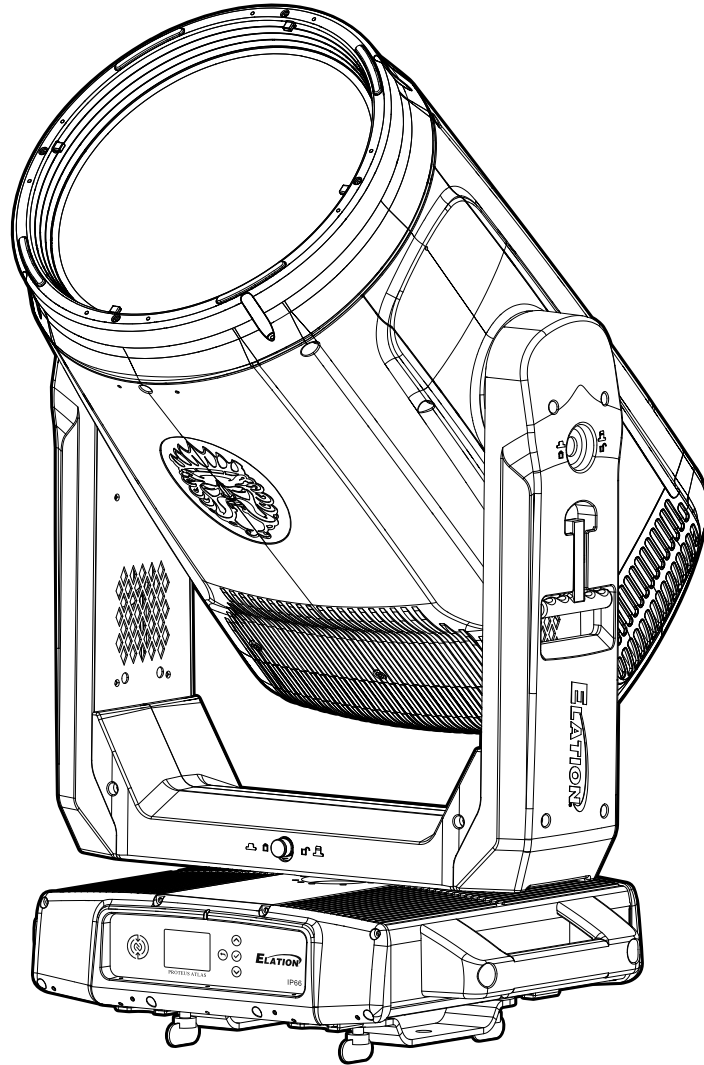

PROTEUS ATLAS

user manual

©2024 **ELATION PROFESSIONAL** all rights reserved. Information, specifications, diagrams, images, and instructions herein are subject to change without notice. ELATION PROFESSIONAL logo and identifying product names and numbers herein are trademarks of ELATION PROFESSIONAL. Copyright protection claimed includes all forms and matters of copyrightable materials and information now allowed by statutory or judicial law or hereinafter granted. Product names used in this document may be trademarks or registered trademarks of their respective companies and are hereby acknowledged. All non-ELATION brands and product names are trademarks or registered trademarks of their respective companies.

ELATION PROFESSIONAL and all affiliated companies hereby disclaim any and all liabilities for property, equipment, building, and electrical damages, injuries to any persons, and direct or indirect economic loss associated with the use or reliance of any information contained within this document, and/or as a result of the improper, unsafe, insufficient and negligent assembly, installation, rigging, and operation of this product.

Elation Professional USA | 6122 S. Eastern Ave. | Los Angeles, CA. 90040

323-582-3322 | 323-832-9142 fax | www.elationlighting.com | info@elationlighting.com

Elation Professional B.V. | Junostraat 2 | 6468 EW Kerkrade, The Netherlands

+31 45 546 85 66 | +31 45 546 85 96 fax | www.elationlighting.eu | info@elationlighting.eu

Elation Professional Mexico | AV Santa Ana 30 | Parque Industrial Lerma, Lerma, Mexico 52000

+52 (728) 282-7070

DOCUMENT VERSION



Due to additional product features and/or enhancements, an updated version of this document may be available online. Please scan the QR Code with your mobile device or visit www.elationlighting.com for the latest revision/update of this manual, before installation and/or programming.

Date	Document Version	Software Version	DMX Channels	Notes
06/25/2024	1.0	1.0.1	26/36	Initial release

CONTENTS

General Information	4
IP66 Rated	5
Limited Warranty (USA Only)	6
Safety Guidelines	7
Overview	9
Colors and Gobos	11
Custom Gobos	13
Gobo Installation	14
Torque Settings for Screws	15
IP Test Parameters	16
Installation Guidelines	17
Sun Protection Mode Hibernation Mode	23
Fan Modes and Low Noise Operation	24
System Menu	25
Dimmer Modes and Dimmer Curves	27
DMX Traits: Channel Functions & Values	28
Remote Device Management (RDM)	36
Error Codes	37
Software Updates	38
Maintenance Guidelines	39
Specifications	44
Dimensional Drawings	45
Optional Accessories	47

INTRODUCTION

Please read and understand the instructions in this manual carefully and thoroughly before attempting to operate this device. These instructions contain important safety and use information. **This device is intended for use by trained personnel only, and is not suitable for private use.**

UNPACKING

Every device has been thoroughly tested and has been shipped in perfect operating condition. Carefully check the shipping carton for damage that may have occurred during shipping. If the carton is damaged, carefully inspect the device for damage, and be sure all accessories necessary to install and operate the device have arrived intact. In the event that damage has been found or parts are missing, please contact our customer support team for further instructions. Please do not return this device to your dealer without first contacting customer support. Please do not discard the shipping carton in the trash. Please recycle whenever possible.

IP66 RATED

An IP rated lighting fixture is commonly installed in outdoor environments and has been designed with an enclosure that effectively protects against the ingress (entry) of external foreign objects such as dust and water. The International Protection (IP) rating system is commonly expressed as "IP" followed by two numbers (i.e. IP66) where the numbers define the degree of protection. The first digit (Foreign Bodies Protection) indicates the extent of protection against particles entering the fixture, while the second digit (Water Protection) indicates the extent of protection against water entering the fixture. **An IP66 rated lighting fixture, such as this one, has been designed and tested to protect against the ingress of dust (6) and powerful water jets from any direction (6).**

BOX CONTENTS

Omega Brackets (x2)

IP66 Rated 5-pin DMX Cable (x1)

IP66 Rated RJ45 Data Cable (x1) - **FIXTURE TO FIXTURE INTERCONNECTION USE ONLY!**

IP66 Locking Power Cable (x1)

CUSTOMER SUPPORT

Contact ELATION Service for any product related service and support needs.

Also visit forums.elationlighting.com with questions, comments or suggestions.

ELATION SERVICE USA - Monday - Friday 8:00am to 4:30pm PST

323-582-3322 | Fax 323-832-9142 | support@elationlighting.com

ELATION SERVICE EUROPE - Monday - Friday 08:30 to 17:00 CET

+31 45 546 85 63 | Fax +31 45 546 85 96 | support@elationlighting.eu

REPLACEMENT PARTS - please visit parts.elationlighting.com

IP66 RATING

The **International Protection (IP)** rating system is denoted as “**IP**” (Ingress Protection) followed by two numbers (e.g., IP66), signifying the level of protection. The initial digit (Protection from Foreign Bodies) indicates the degree of safeguarding against solid particles entering the fixture, while the second digit (Protection from Water) specifies defense against water ingress. An **IP66** rated lighting fixture is meticulously designed and rigorously tested to shield against dust infiltration (**6**) and powerful water jets from any direction (**6**).

Maritime/Coastal Environment Installations:

Coastal environments are located near the sea and pose a corrosive risk to electronics due to exposure to atomized saltwater and high humidity. Maritime settings encompass areas within a 5-mile radius of coastal environments.

Maritime installations necessitate additional precautions and may require more frequent servicing due to their challenging environmental conditions. It’s essential to understand that IP ratings are initially based on freshwater conditions, while maritime environments are generally more “corrosive” to IP fixtures, both internally and externally. Periodic operation may be necessary during periods of high humidity and low temperatures to expel accumulated moisture through the vent valve. Recommendations may vary based on specific installation circumstances.

NOTE: Not all features mentioned apply to all fixtures; these instructions may not be relevant to your specific model. For more information, please contact our support team.

Exterior Maintenance: Inspect the exterior every 30 days. Ensure the unit is powered off/disconnected. Examine the chassis for contaminants and clean optics and chassis as necessary. Schedule maintenance based on findings, considering the exterior’s exposure to the elements. Maintenance is crucial even when luminaires are not in use due to their exterior placement. Applying durable wax to the chassis is recommended to prevent contaminant buildup. Regularly inspect power and data lines for contaminants or corrosion, periodically reapplying dielectric grease, particularly in coastal settings. Clean thoroughly and/or replace connectors if corrosion/contaminants are present. Annual replacement of vent valves is preventive to ensure proper humidity venting. Also, inspect mounting hardware as a precaution.

Interior Maintenance: Inspect the interior every 30 days with the unit powered off/disconnected.

- Examine zoom/focus mechanisms, clean optics, and lubricate linear bearings (Krytox oil) as needed.
- Inspect belts for wear.
- Manually rotate all rotating effect wheels and note any resistance.
- Check remaining rotating belts for wear.
- Inspect and clean fans as required, checking rotation and connections
- Examine the CMY module, manually moving flags and checking for resistance
- Clean guide rods if needed and apply a thin layer of grease (moly lube).
- Clean the interior with low-volume compressed air and clean optics before reassembling head covers.

The pan belt should be inspected for wear, although the base has limited moving parts. Always conduct an IP test when removing any cover.

There is no specific timeframe for routine replacement of parts like belts, stepper motors, PCBs, or LEDs. Replace these items as needed, except for cooling fans, which should be replaced after 10,000 hours of operation as a preventive measure to ensure proper functioning of internal components. A comprehensive service breakdown is available; contact service@elationlighting.com for parts or manuals.

LIMITED WARRANTY (USA ONLY)

- A. Elation Professional hereby warrants, to the original purchaser, Elation Professional products to be free of manufacturing defects in material and workmanship for a period of two years (730 days), and Elation Professional product rechargeable batteries to be free of manufacturing defects in material and workmanship for a period of six months (180 days), from the original date of purchase. This warranty excludes discharge lamps and all product accessories. This warranty shall be valid only if the product is purchased within the United States of America, including possessions and territories. It is the owner's responsibility to establish the date and place of purchase by acceptable evidence, at the time service is sought.
- B. For warranty service, send the product only to the Elation Professional factory. All shipping charges must be pre-paid. If the requested repairs or service (including parts replacement) are within the terms of this warranty, Elation Professional will pay return shipping charges only to a designated point within the United States. If any product is sent, it must be shipped in its original package and packaging material. No accessories should be shipped with the product. If any accessories are shipped with the product, Elation Professional shall have no liability what so ever for loss and/or damage to any such accessories, nor for the safe return thereof.
- C. This warranty is void if the product serial number and/or labels are altered or removed; if the product is modified in any manner which Elation Professional concludes, after inspection, affects the reliability of the product; if the product has been repaired or serviced by anyone other than the Elation Professional factory unless prior written authorization was issued to purchaser by Elation Professional; if the product is damaged because not properly maintained as set forth in the product instructions, guidelines and/or user manual.
- D. This is not a service contract, and this warranty does not include any maintenance, cleaning or periodic check-up. During the periods as specified above, Elation Professional will replace defective parts at its expense, and will absorb all expenses for warranty service and repair labor by reason of defects in material or workmanship. The sole responsibility of Elation Professional under this warranty shall be limited to the repair of the product, or replacement thereof, including parts, at the sole discretion of Elation Professional. All products covered by this warranty were manufactured after January 1, 1990, and bare identifying marks to that effect.
- E. Elation Professional reserves the right to make changes in design and/or performance improvements upon its products without any obligation to include these changes in any products theretofore manufactured.
- F. No warranty, whether expressed or implied, is given or made with respect to any accessory supplied with the products described above. Except to the extent prohibited by applicable law, all implied warranties made by Elation Professional in connection with this product, including warranties of merchantability or fitness, are limited in duration to the warranty periods set forth above. And no warranties, whether expressed or implied, including warranties of merchantability or fitness, shall apply to this product after said periods have expired. The consumer's and/or dealer's sole remedy shall be such repair or replacement as is expressly provided above; and under no circumstances shall Elation Professional be liable for any loss and/or damage, direct and/or consequential, arising out of the use of, and/or the inability to use, this product.
- G. This warranty is the only written warranty applicable to Elation Professional products and supersedes all prior warranties and written descriptions of warranty terms and conditions heretofore published.

WARRANTY RETURNS

All returned service items whether under warranty or not, must be freight pre-paid and accompany a return authorization (R.A.) number. The R.A. number must be clearly written on the outside of the return package. A brief description of the problem as well as the R.A. number must also be written down on a piece of paper and included in the shipping container. If the unit is under warranty, you must provide a copy of your proof of purchase invoice. Items returned without a R.A. number clearly marked on the outside of the package will be refused and returned at customer's expense. You may obtain a R.A. number by contacting customer support.

SAFETY GUIDELINES

This fixture is a sophisticated piece of electronic equipment. To guarantee a smooth operation, it is important to follow all instructions and guidelines in this manual. Elation Professional is not responsible for injury and/or damages resulting from the misuse of this fixture due to the disregard of the information printed in this manual. Only qualified and/or certified personnel should perform installation of this fixture and only the original rigging parts (omega brackets) included with this fixture should be used for installation. Any modifications to the fixture and/or the included mounting hardware will void the original manufacturer's warranty and increase the risk of damage and/or personal injury.

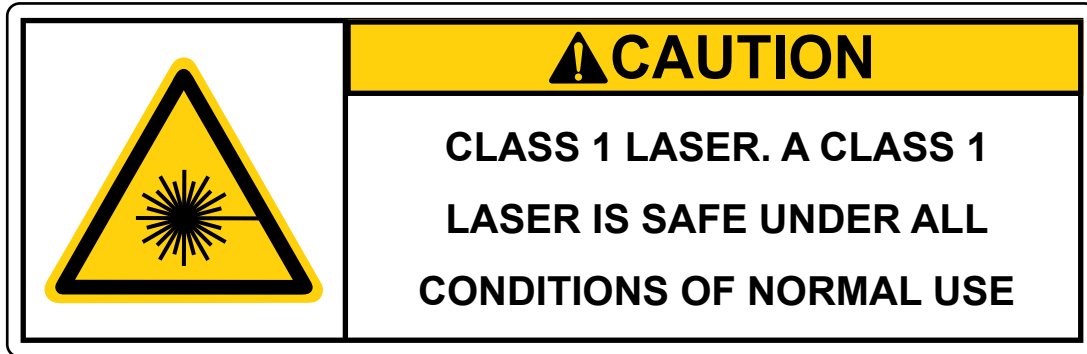

PROTECTION CLASS 1 - FIXTURE MUST BE PROPERLY GROUNDED.



CLASS 1 LASER IS SAFE UNDER ALL CONDITIONS OF NORMAL USE AND CONFORMS TO IEC 60825-1:2014



CAUTION: USE OF CONTROLS, ADJUSTMENTS, OR PROCEDURES OTHER THAN THOSE SPECIFIED HEREIN MAY RESULT IN EXPOSURE TO HAZARDOUS CLASS 3B INVISIBLE LASER RADIATION.



THERE ARE NO USER SERVICEABLE PARTS INSIDE THIS UNIT. DO NOT ATTEMPT ANY REPAIRS YOURSELF; DOING SO WILL VOID YOUR MANUFACTURER'S WARRANTY. DAMAGES RESULTING FROM MODIFICATIONS TO THIS FIXTURE AND/OR THE DISREGARD OF SAFETY INSTRUCTIONS AND GUIDELINES IN THIS MANUAL VOID THE MANUFACTURER'S WARRANTY AND ARE NOT SUBJECT TO ANY WARRANTY CLAIMS AND/OR REPAIRS.



ENSURE ALL CONNECTIONS AND END CAPS ARE PROPERLY SEALED WITH A DIELECTRIC GREASE (AVAILABLE AT MOST ELECTRICAL SUPPLIERS) TO PREVENT WATER CORROSION AND/OR ELECTRICAL SHORT CIRCUIT.



**DO NOT PLUG FIXTURE INTO A DIMMER PACK!
NEVER OPEN THIS FIXTURE WHILE IN USE!
UNPLUG POWER BEFORE SERVICING FIXTURE!
NEVER TOUCH FIXTURE DURING OPERATION, AS IT MAY BE HOT!
KEEP FLAMMABLE MATERIALS AWAY FROM FIXTURE!**



**NEVER LOOK DIRECTLY INTO THE LIGHT SOURCE!
RETINA INJURY RISK - MAY INDUCE BLINDNESS!
SENSITIVE PERSONS MAY SUFFER AN EPILEPTIC SHOCK!**



MINIMUM DISTANCE OF INFLAMMABLE MATERIALS FROM THE SURFACE 1.6 FEET (0.5 METER)

SAFETY GUIDELINES

- **DO NOT TOUCH** the fixture housing during operation. Turn OFF the power and allow approximately 15 minutes for the fixture to cool down before serving.
- **DO NOT** shake fixture, avoid brute force when installing and/or operating fixture.
- **DO NOT** operate fixture if the power cord is frayed, crimped damaged and/or if any of the power cord connectors are damaged and do not insert into the fixture securely with ease.
- **NEVER** force a power cord connector into the fixture. If the power cord or any of its connectors are damaged, replace it immediately with a new one of similar power rating.
- **DO NOT** block any air ventilation slots.
- All fan and air inlets must remain clean and never blocked.
- Allow approx. 10''(25cm) between fixture and other devices or a wall for proper cooling.
- When installing fixture in a suspended environment, always use mounting hardware that is no less than M10x25mm, and always install fixture with an appropriately rated safety cable.
- Always disconnect fixture from main power source before performing any type of service and/or cleaning procedure. Only handle the power cord by the plug end, never pull out the plug by tugging the wire portion of the cord.
- During the initial operation of this fixture, a light smoke or smell may emit from the interior of the fixture. This is a normal process and is caused by excess paint in the interior of the casing burning off from the heat associated with the lamp and will decrease gradually over time.
- Consistent operational breaks will ensure the fixture will function properly for many years.
- **ONLY** use the original packaging and materials to transport the fixture in for service.

OVERVIEW

NFC Access Point LCD Display Up Button Enter Button

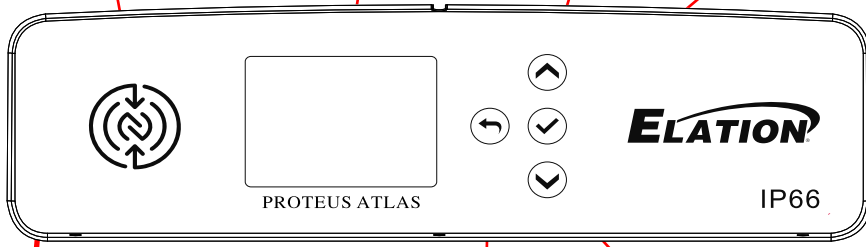

Lens Back Button Down Button

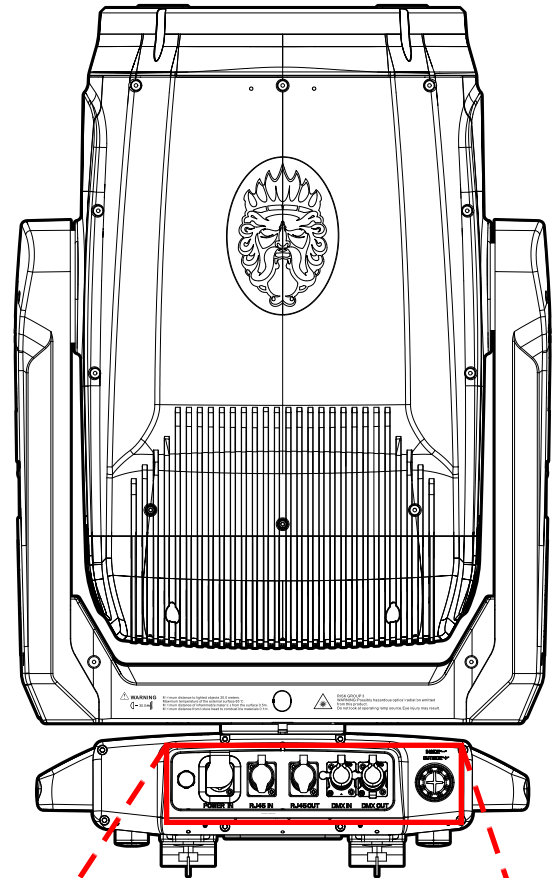
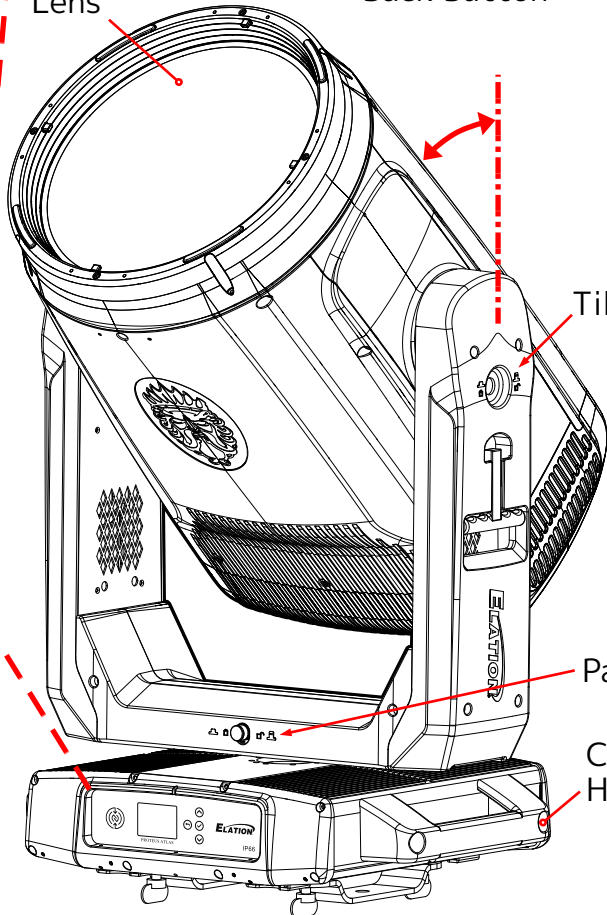

NOTE: TO MAINTAIN THE IP66 RATING INTEGRITY OF THE FIXTURE AND PREVENT WATER FROM ENTERING THE FIXTURE, SEAL ALL UNUSED CONNECTION RUBBER CAPS.

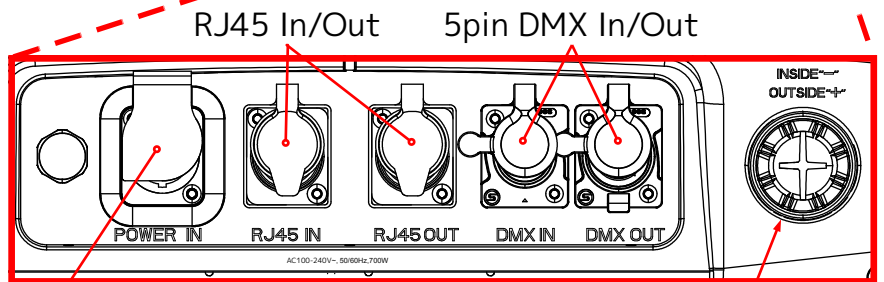

Power In
AC100-240V~, 50/60Hz, 700W

Battery Compartment

OVERVIEW

Distance to Surfaces Warning

Radiation & Eye Injury Warning

WARNING Minimum distance to lighted objects 40.0 meters.
 Maximum temperature of the external surface 65°C.
 Minimum distance of inflammable materials from the surface 0.5m.
 Minimum distance from fixture head to combustible materials 0.1m.

RISK GROUP 3
WARNING: Possibly hazardous optical radiation emitted from this product.
 Do not look at operating lamp source. Eye injury may result.

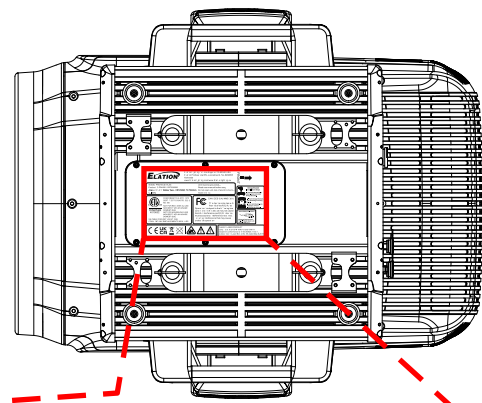
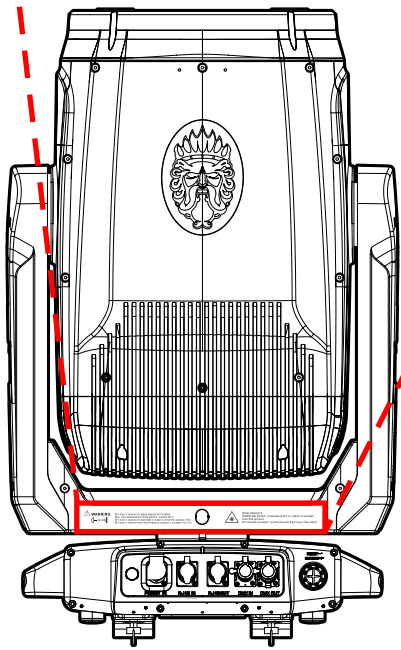

Manufacturer Information

Model Information & Usage Warnings

cETLus Label

Certifications & Warnings

ELATION Elation Lighting Inc- Los Angeles-CA 90040 USA
 Elation Professional BV- Junostraat 2 -NL-6468EW Kerkrade
 www.Elationlighting.com/www.Elationlighting.eu

FRONT →

MODEL: PROTEUS ATLAS
 Product ID: PRA501/1237000285
 Angle: 0.6°~8.5° Battery Type: ICR14500(3.7V 700mAh)
 t_a=45°C

Unit must be grounded.
 Read user manual before use.
 Do not open unit, risk of electric shock.
 Made in China

ETL LISTED US
 CONFORMS TO UL STD. 1573
 CERTIFIED TO CSA STD. C22.2
 NO:166
Intertek
 4010832
 NOT FOR RESIDENTIAL USE
 NON DESTINÉ À UN USAGE DOMESTIQUE
 NOT FOR HOUSEHOLD USE
 NON DESTINÉ À UN USAGE DOMESTIQUE
 SUITABLE FOR WET LOCATIONS
 CONVIENT AUX EMPLACEMENTS MOUILLES

FC CAN ICES-3(A)/NMB-3(A)
 This device complies with Part 15 of the FCC Rules:
 Operation is subject to the following two conditions: (1) this device may not cause harmful interference, and (2) this device must accept any interference received, including interference that may cause undesirable operation.

Omega Bracket Installation Steps
 1. Attached appropriately rated clamps onto both Omega Brackets.
 2. Insert Omega Brackets into matching mounting holes.
 3. Turn both Quick-Lock Fasteners 1/4 turn clockwise to secure.

Attach Safety Cable Here!
 Minimum Requirements:
 12-Fold Weight Quick Link Shackle with Hook

CE UK CA

CLASS 1 LASER PRODUCT
 Complies with 21 CFR 1040.10 and 1040.11
 except for conformance with IEC 60825-1 Ed.3.,
 as described in Laser Notice No. 56, dated May 8, 2019

Omega Bracket Guidelines

Safety Cable Label

FCC Label

Class 1 Laser Warning

COLORS AND GOBOS

COLOR FLAGS

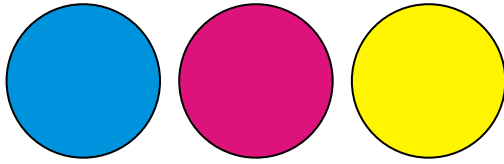

CYAN

MAGENTA

YELLOW

COLOR WHEEL

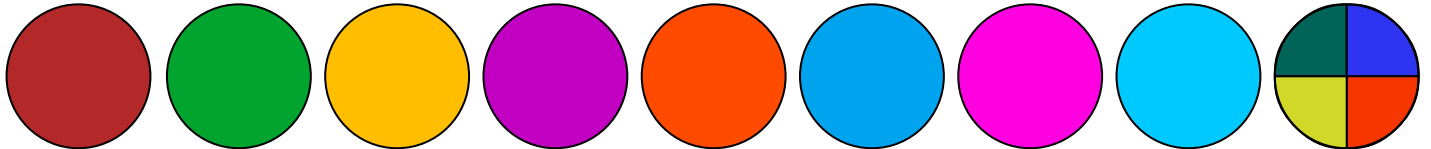

POS 1
RED

POS 2
GREEN

POS 3
YELLOW

POS 4
MAGENTA

POS 5
ORANGE

POS 6
CYAN II

POS 7
PINK

POS 8
CYAN

POS 9
QUAD
COLOR

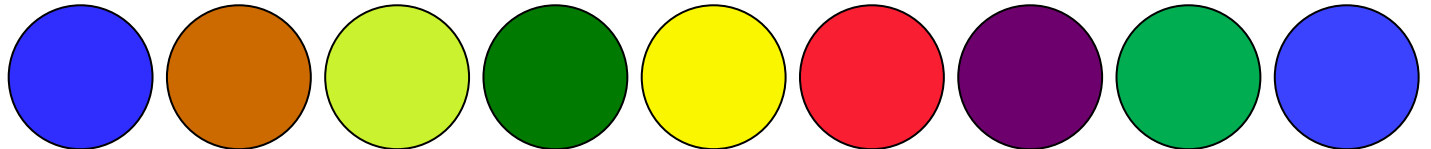

POS 10
DEEP BLUE

POS 11
AMBER

POS 12
YELLOW
GREEN

POS 13
GREEN II

POS 14
LIGHT
YELLOW

POS 15
RED
ORANGE

POS 16
WINE PINK

POS 17
KELLY
GREEN

POS 18
LIGHT
BLUE

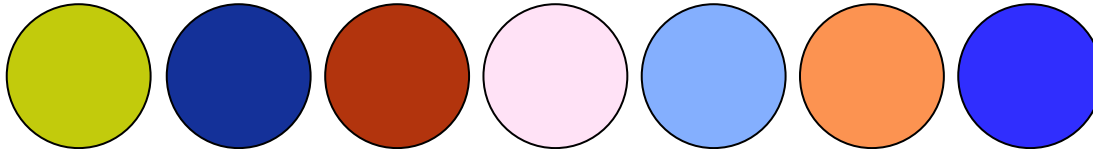

POS 19
DEEP
YELLOW

POS 20
BLUE II

POS 21
RED
AMBER

POS 22
HCRI

POS 23
CTB

POS 24
CTO

POS 25
BLUE

INTERCHANGEABLE ROTATING GOBO WHEEL



POS 1

POS 2

POS 3

POS 4

POS 5

POS 6

POS 7

POS 8

POS 9

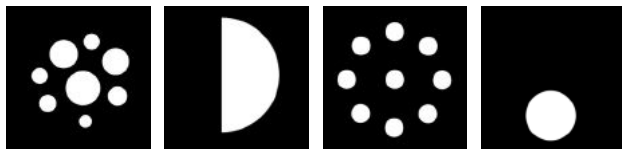

POS 10

POS 11

POS 12

POS 13

COLORS AND GOBOS

FIXED GOBO WHEEL

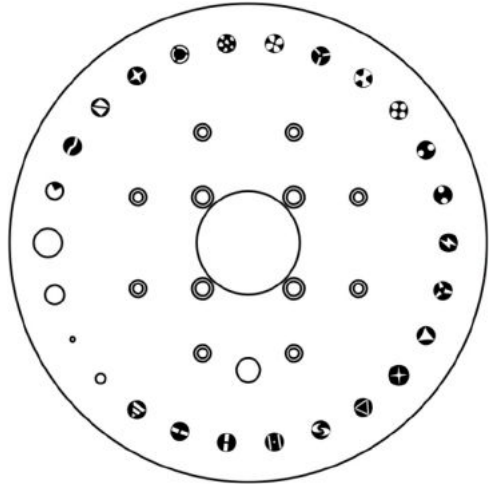
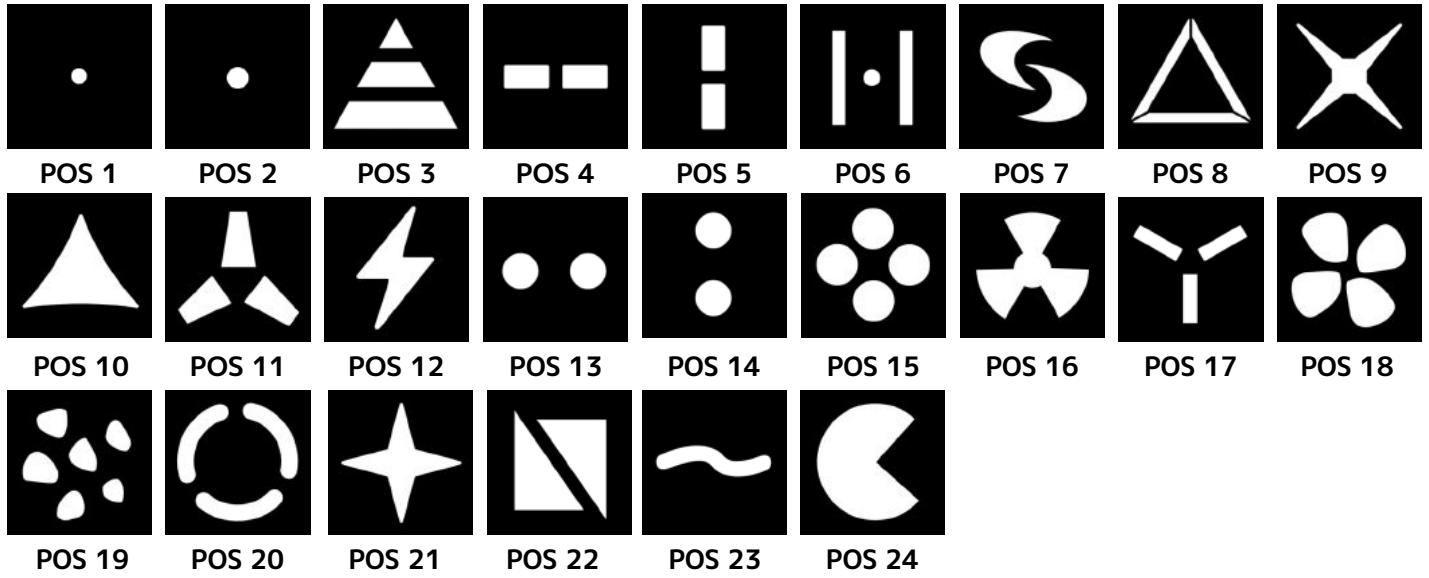

FX WHEEL 1

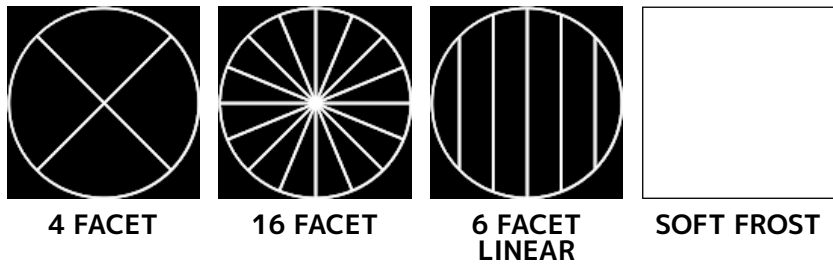

FX WHEEL 2

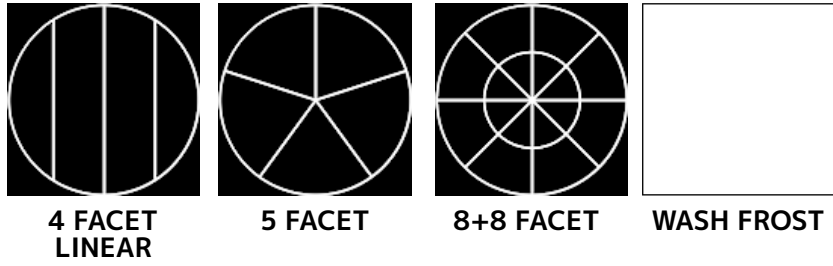

COLORS AND GOBOS - CUSTOM GOBOS

ROTATING GOBO WHEEL GOBOS	
Gobo O.D. (Max. Outer Diameter)	Ø6.9mm
Gobo I.D. (Max. Image Diameter)	Ø3mm
Gobo Thickness	.5mm
Gobo Material	METAL

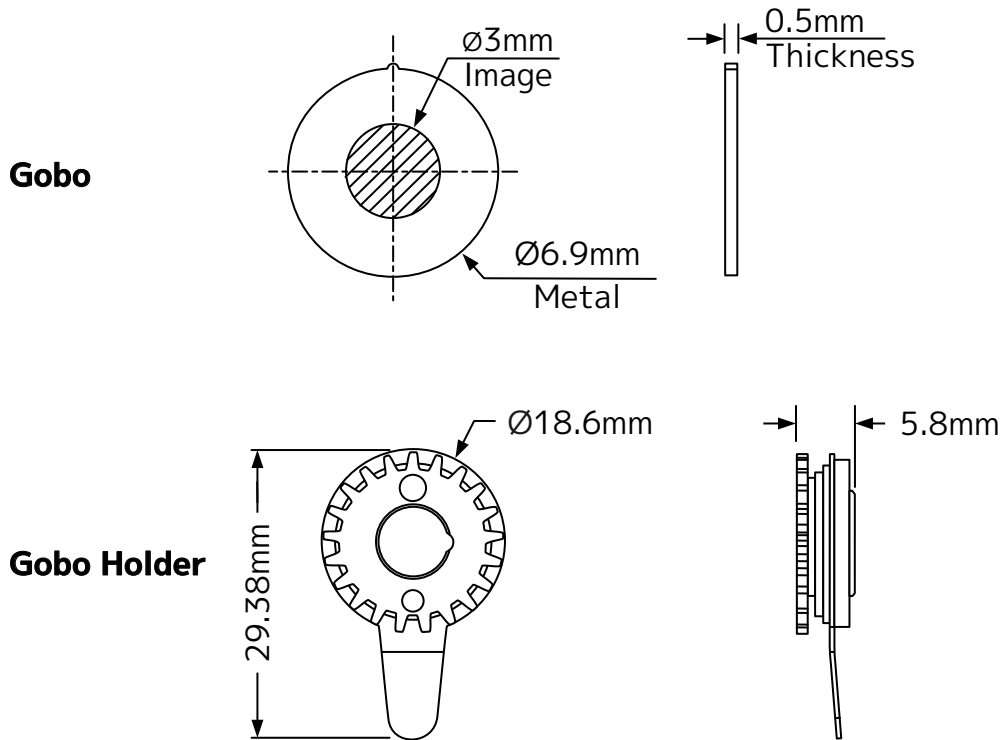

Please be aware of the intended position and correct sizing requirements of custom gobos.

***** IMPORTANT NOTICE REGARDING CUSTOM GOBOS *****

Due to the high temperature optical system, special material is required for custom gobos. Due to varying manufacturing processes and tolerances, it is highly recommended to provide a gobo sample and holder from the fixture to the custom gobo vendor for accurate sizing. Extended testing of custom gobo designs is highly recommended prior to use. Contact ELATION SERVICE for further information.

ELATION SERVICE USA -Monday -Friday 8:00am to 4:30pm PST
323-582-3322 | support@elationlighting.com

ELATION SERVICE EUROPE -Monday -Friday 08:30 to 17:00 CET
+31 45 546 85 63 | support@elationlighting.eu

GOBO INSTALLATION

GOBO REPLACEMENT

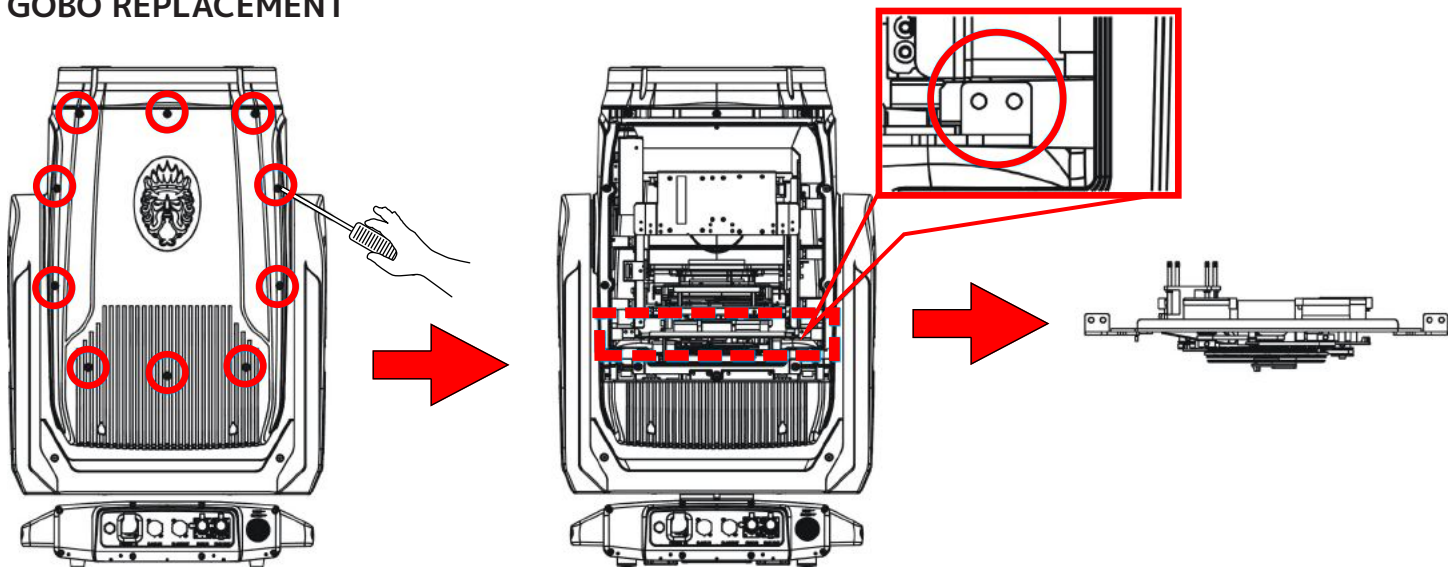

Place the fixture on a firm flat surface. Locate the (10x) screws on the side of the moving head and remove them. With the panel set aside, locate the Pattern Bracket Assembly and remove the (4x) screws that secure it to the internal housing frame.

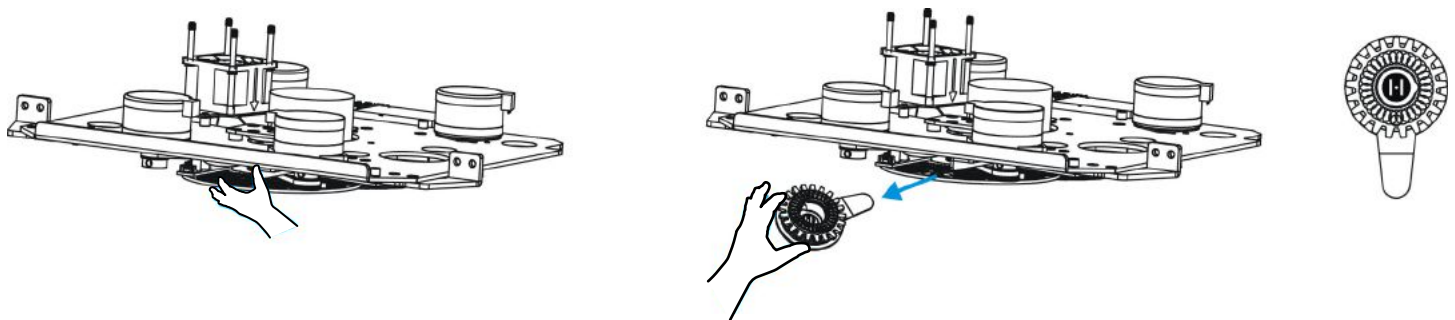

Locate the specific Rotating Gobo to replace. Carefully grip the Gobo using your thumb and index finger, gently lift it slightly, and then pull it out and away until it fully clears the Gobo Wheel.

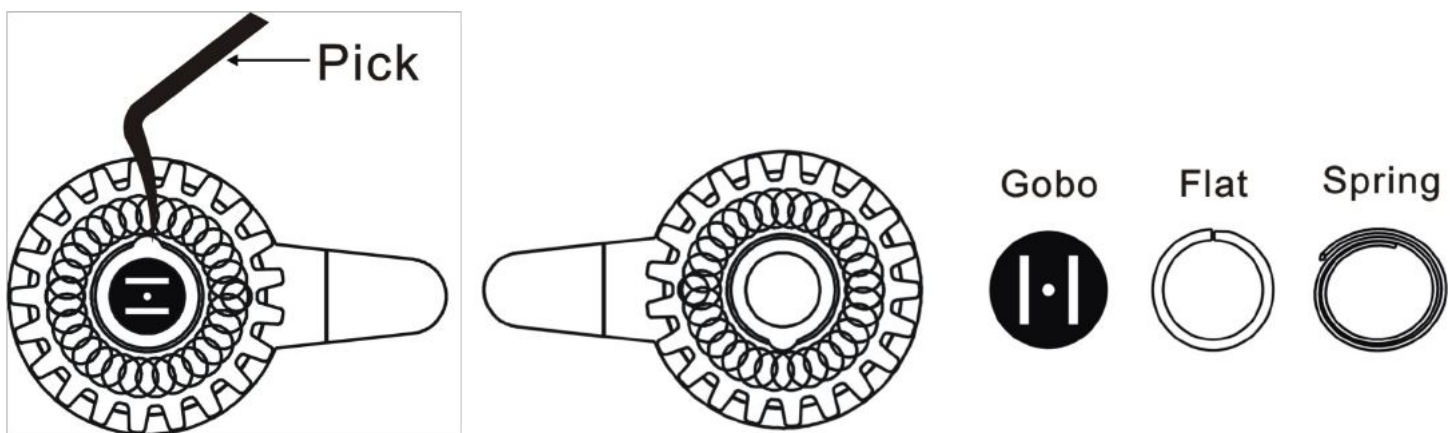

Locate the tab of the spring, and with a precision pick (or similar tool), carefully press the retaining spring inward to relieve the tension. Remove the retaining spring and carefully separate the GOBO from the GOBO Holder. Lastly, remove the flat washer attached to the removed GOBO and attach it to the desired replacement GOBO. Install the replacement Rotating GOBO following the steps above in reverse order.

TORQUE SETTINGS FOR SCREWS



PANEL SCREWS MUST BE TIGHTENED WITH A TORQUE WRENCH ACCORDING TO THE TORQUE SPECIFICATION DESCRIBED BELOW.

The hex-head screws holding the panels **MUST** be tightened with a torque wrench (Torque Wrench Not Included).



CAUTION! DO NOT OVER TORQUE SCREWS AS THIS CAN CAUSE LEAKAGE ISSUES! TO CONFIRM THE IP66 INTEGRITY AFTER A PROCEDURE REQUIRING DISASSEMBLY/REASSEMBLY, TEST THE FIXTURE USING THE IP TESTER. CONTACT ELATION SERVICE FOR MORE DETAILS.



CAUTION! THE USE OF PROTECTIVE GLOVES AND SAFETY GOGGLES IS STRONGLY RECOMMENDED WHILE PERFORMING THE IP PRESSURE TEST! AVOID PLACING YOUR FACE, EYES, HANDS, ETC IN CLOSE PROXIMITY TO THE FIXTURE'S LENS WHILE PERFORMING THE TEST!

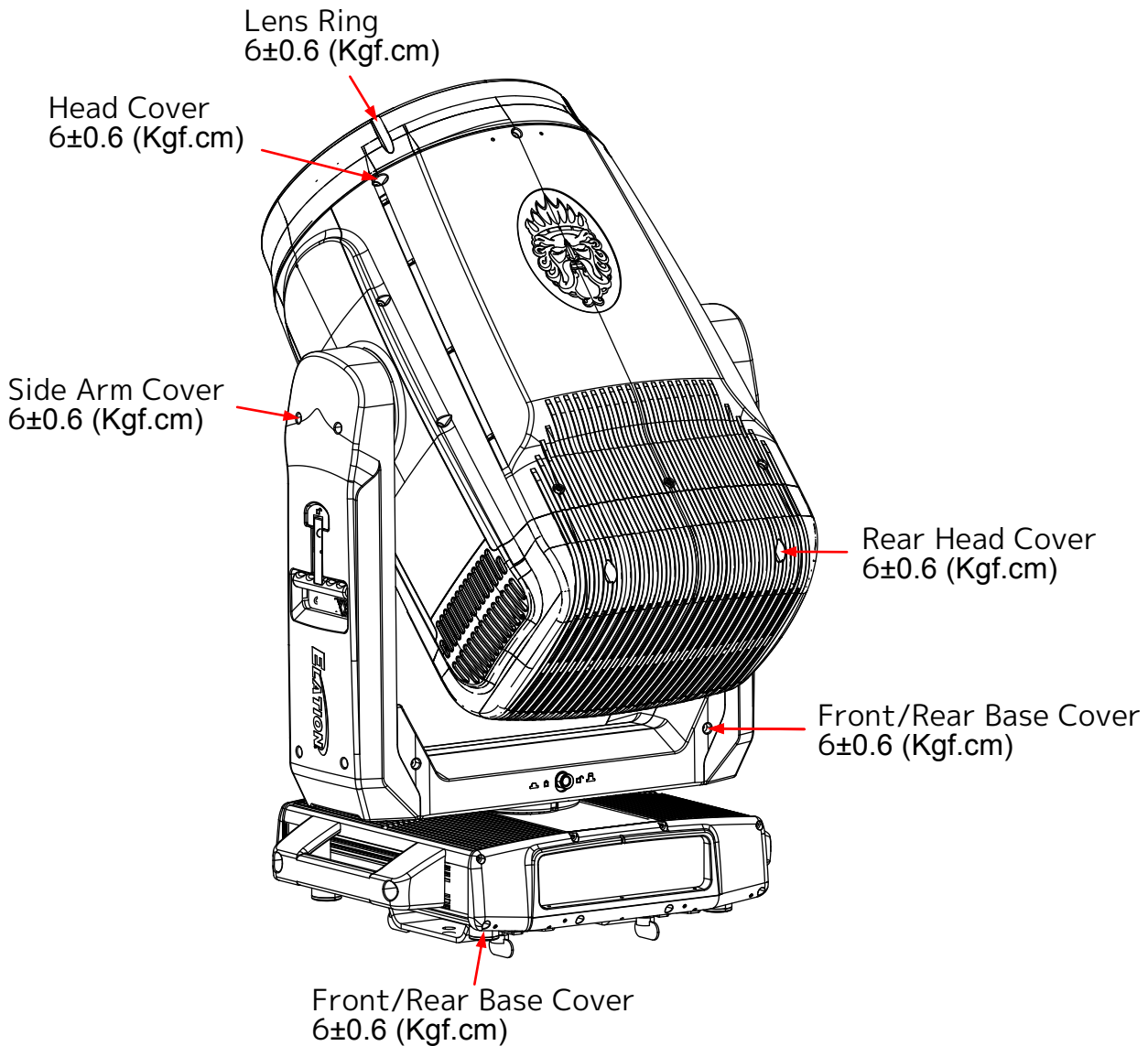

IP TEST PARAMETERS

Following any repair or maintenance procedure that requires disassembly of the fixture, use Elation's IP Tester to confirm the IP integrity of the fixture. Please contact Elation Service for information regarding the Elation IP Tester, or visit the product information page online at: <https://www.elationlighting.com/ip-tester>



CAUTION! THE USE OF PROTECTIVE GLOVES AND SAFETY GOGGLES IS STRONGLY RECOMMENDED WHILE PERFORMING THE IP PRESSURE TEST! AVOID PLACING YOUR FACE, EYES, HANDS, ETC IN PROXIMITY TO THE LENS OF THE FIXTURE WHILE PERFORMING THE TEST!

DE-HUMIDIFICATION: IP66 fixtures operating in high-humidity environments may experience residual fogging or condensation. Such fogging will not affect the fixture, and can be removed using the following procedure: position the unit with the air valve pointing upwards, then open the air valve and run the unit for 1-2 hours after reaching operating temperature. Then, while the fixture is still hot, re-install the air valve and allow the unit to cool down. Please note: this procedure should be performed in a dry, climate-controlled environment. Avoid additional fogging by drying the fixture completely before placing into a road case.

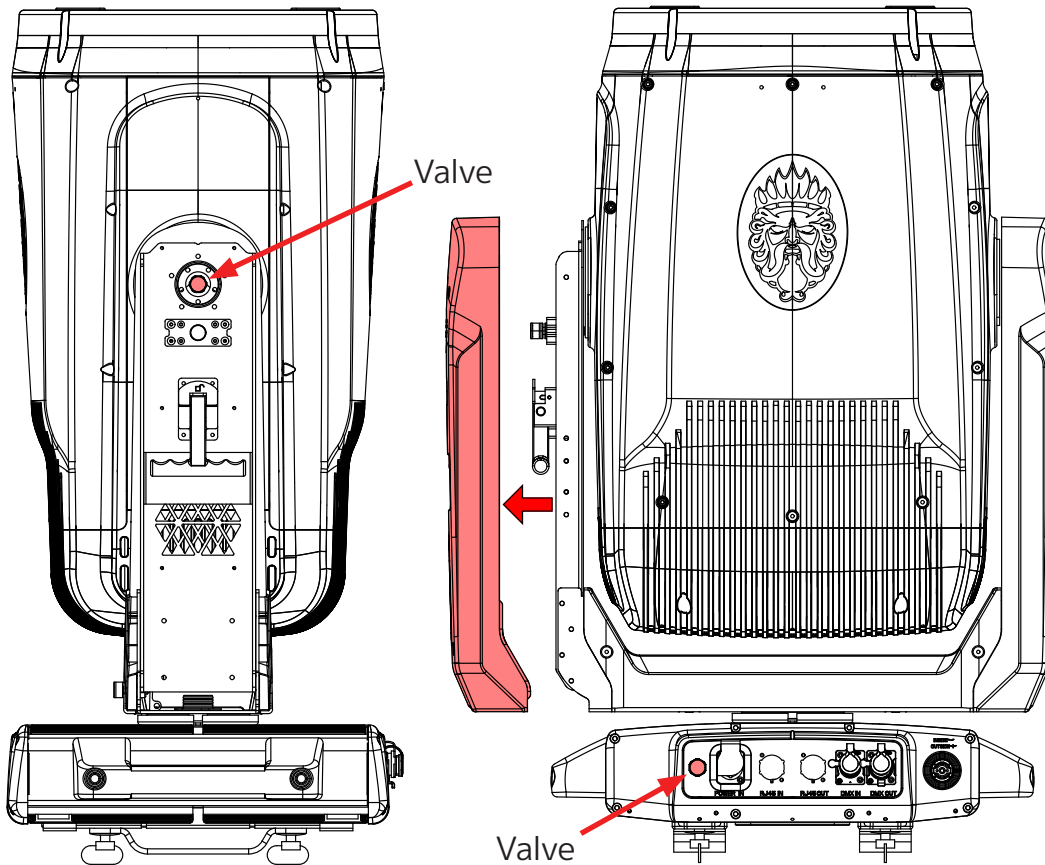

IP PRESSURE TESTING PARAMETERS			
Test Type	Low Pressure Limit	High Pressure Limit	Hold Time
Vacuum Test	-4.35psi (-30.00 KPa)	-5.08psi (-35.00 KPa)	10s
Pressure Test	3.62psi (25.00 KPa)	4.35psi (30.00 KPa)	10s



INSTALLATION GUIDELINES



FLAMMABLE MATERIAL WARNING

Keep fixture minimum 164 feet (40m) away from flammable materials and/or pyrotechnics.



ELECTRICAL CONNECTIONS

A qualified electrician should be used for all electrical connections and/or installations.



USE CAUTION WHEN POWER LINKING OTHER MODEL FIXTURES AS THE POWER CONSUMPTION OF OTHER MODEL FIXTURES MAY EXCEED THE MAX POWER OUTPUT ON THIS FIXTURE. CHECK SILK SCREEN FOR MAX AMPS.



MINIMUM DISTANCE TO OBJECTS/SURFACES MUST BE 1.6 FEET (0.5 METERS)



MAXIMUM TEMPERATURE OF EXTERNAL SURFACE 149°F (65°C)



DO NOT INSTALL THE FIXTURE IF YOU ARE NOT QUALIFIED TO DO SO!

Fixture **MUST** be installed following all local, national, and country commercial electrical and construction codes and regulations.

Before rigging/mounting the fixture to any metal truss/structure or placing the fixture on any surface, a professional equipment installer **MUST** be consulted to determine if the metal truss/structure or surface is properly certified to safely hold the combined weight of the fixture, clamps, cables, and accessories.

Fixture ambient operating temperature range is **-4° to 113°F. (-20° to 45°C)**

Do not use the fixture under or above this temperature.

Fixture should be installed in areas outside walking paths, seating areas, or away from areas where unauthorized personnel might reach the fixture by hand.

NEVER stand directly below the fixture when rigging, removing, or servicing. Overhead fixture installation must always be secured with a secondary safety attachment, such as an appropriately rated safety cable.

Allow approximately 10 minutes for the fixture to cool down before serving.

INSTALLATION GUIDELINES

OMEGA BRACKET WITH CLAMP INSTALLATION

When mounting the fixture to a truss, be sure to secure appropriately rated professional grade rigging clamps to the included Omega Brackets using an M10 or M12 screw fitted through the center hole of the Omega Brackets. **This fixture requires the installation of two Omega brackets and two clamps for secure truss mounting.**

Mount Truss Clamp to Omega Bracket with M10 or M12 screw fitted through the center hole of Omega Bracket.

The fixture also provides a built-in attachment point for a **SAFETY CABLE**. Be sure to only use the designated attachment point for the safety cable and never secure a safety cable to a carrying handle.



ALWAYS ATTACH A SAFETY CABLE WHENEVER INSTALLING THIS FIXTURE IN A SUSPENDED ENVIRONMENT TO ENSURE THAT THE FIXTURE WILL NOT FALL IF THE CLAMP FAILS.

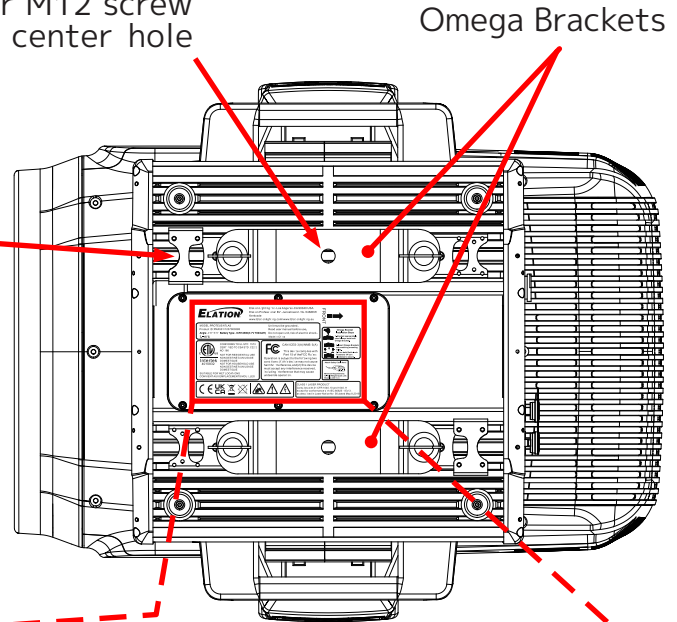

ELATION

Elation Lighting Inc- Los Angeles-CA 90040 USA
 Elation Professional BV- Junostraat 2 -NL-6468EW
 Kerkrade
www.Elationlighting.com/www.Elationlighting.eu

FRONT

MODEL:PROTEUS ATLAS

Product ID:PRA501/1237000285

Angle: 0.6°~8.5° Battery Type: ICR14500(3.7V 700MAH)

t_a=45°C

Unit must be grounded.

Read user manual before use.

Do not open unit,risk of electric shock.

Made in China



CONFORMS TO UL STD. 1573
 CERTIFIED TO CSA STD. C22.2
 NO:166

Intertek
 4010832

NOT FOR RESIDENTIAL USE
 NON DESTINÉ À UN USAGE
 DOMESTIQUE
 NOT FOR HOUSEHOLD USE
 NON DESTINÉ À UN USAGE
 DOMESTIQUE

SUITABLE FOR WET LOCATIONS
 CONVIENT AUX EMPLACEMENTS MOUILLES



CAN ICES-3(A)/NMB-3(A)

This device complies with
 Part 15 of the FCC Rules:

Operation is subject to the following two
 conditions:(1) this device may not cause
 harmful interference,and(2) this device
 must accept any interference received,
 including interference that may cause
 undesirde operation.



**Omega Bracket
 Installation Steps**

1. Attached appropriately
 rated clamps onto both
 Omega Brackets.



2. Insert Omega Brackets
 into matching mounting
 holes.



3. Turn both Quick-Lock
 Fasteners 1/4 turn
 clockwise to secure.

Attach Safety Cable Here!

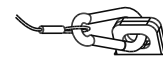

Minimum Requirements:
 12-Fold Weight Quick Link
 Shackle with Hook



CLASS 1 LASER PRODUCT

Complies with 21 CFR 1040.10 and 1040.11
 except for conformance with IEC 60825-1 Ed.3.,
 as described in Laser Notice No. 56,dated May 8,2019

MOUNTING THE FIXTURE ON A TRUSS USING CLAMPS

When mounting the fixture to a truss, be sure to secure an appropriately rated professional grade rigging clamp to the bottom of the fixture using (2x) minimum grade 8.8 steel (2x) M12x25mm bolts fitted through the mounting hole of the Clamp. The fixture provides built-in rigging points for a SAFETY CABLE (not included). Be sure to only use one of the designated rigging points for the safety cable and never secure a safety cable to a carrying handle.

INSTALLATION GUIDELINES

RIGGING

Overhead rigging requires extensive experience, including amongst others calculating working load limits, installation material being used, and periodic safety inspection of all installation material and the fixture. If you lack these qualifications, do not attempt the installation yourself. Improper installation can result in bodily injury. Fixture is fully operational in the specific mounting positions illustrated below.

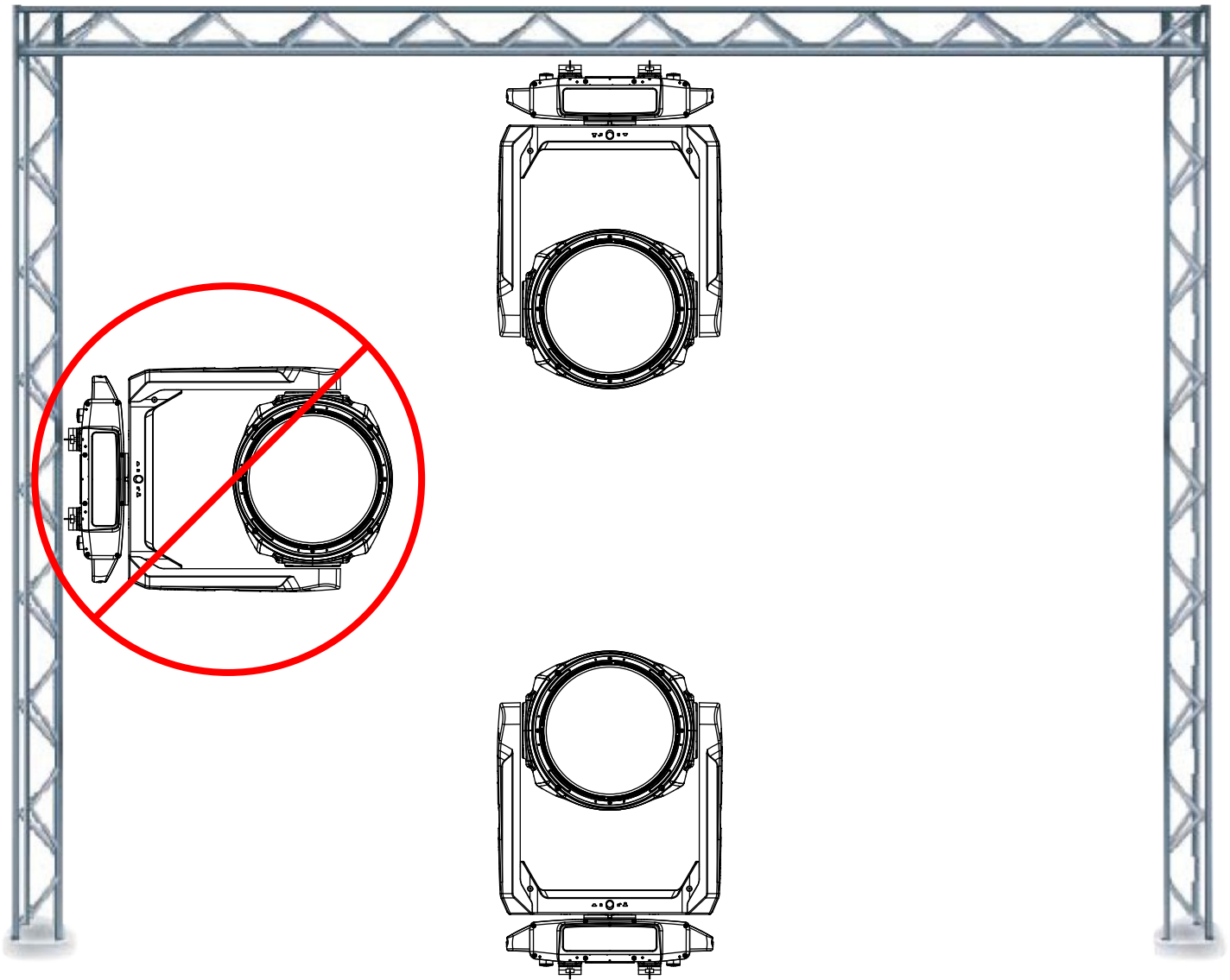

FALLING FIXTURES CAN CAUSE SEVERE INJURY OR SERIOUS EQUIPMENT DAMAGE! FOR THIS REASON, FIXTURES SHOULD BE INSTALLED AND INSPECTED ONLY BY QUALIFIED PERSONNEL. DO NOT INSTALL THE UNIT IF YOU LACK THE QUALIFICATIONS TO DO SO, OR IF YOU HAVE DOUBTS ABOUT THE SAFETY AND SECURITY OF THE INSTALLATION SETUP OR LOCATION!



ALWAYS ATTACH A SAFETY CABLE WHENEVER INSTALLING THIS FIXTURE IN A SUSPENDED ENVIRONMENT TO ENSURE THE FIXTURE WILL NOT FALL IF THE CLAMP FAILS.

INSTALLATION GUIDELINES

ART-NET | sACN CONNECTION

When connecting fixture to a network switch to control multiple devices, a Gigabit Ethernet Switch that supports IGMP (Internet Group Management Protocol) is required. Using a Gigabit Ethernet Switch that does not support IGMP can cause erratic behavior of all connected devices to the switch. Click link below for more information about IGMP.

https://en.wikipedia.org/wiki/Internet_Group_Management_Protocol

POWER AND DATA CABLES



TO MAINTAIN THE IP66 RATING INTEGRITY OF THE FIXTURE, ALL CABLES MUST BE RUN TOWARDS THE GROUND TO PREVENT WATER ACCUMULATION AROUND THE CONNECTIONS.

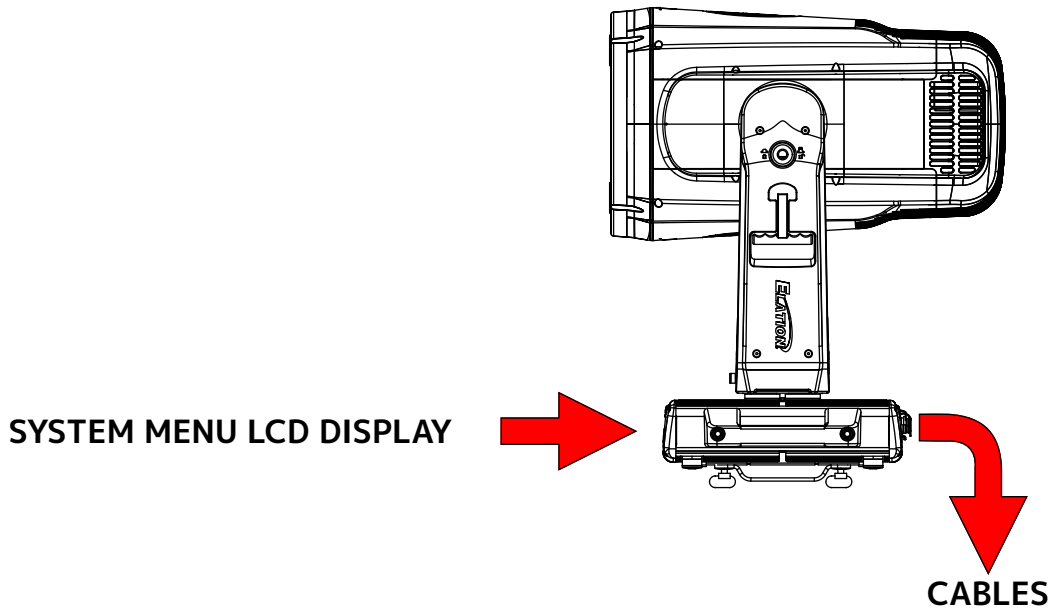

RJ45 DATA CABLES



THE INCLUDED RJ45 DATA CABLE IS FOR FIXTURE TO FIXTURE INTERCONNECTIONS ONLY! THE RJ45 CABLE CONNECTORS MAY NOT BE COMPATIBLE WITH OTHER RJ45 OR ETHERNET TYPE CONNECTORS.

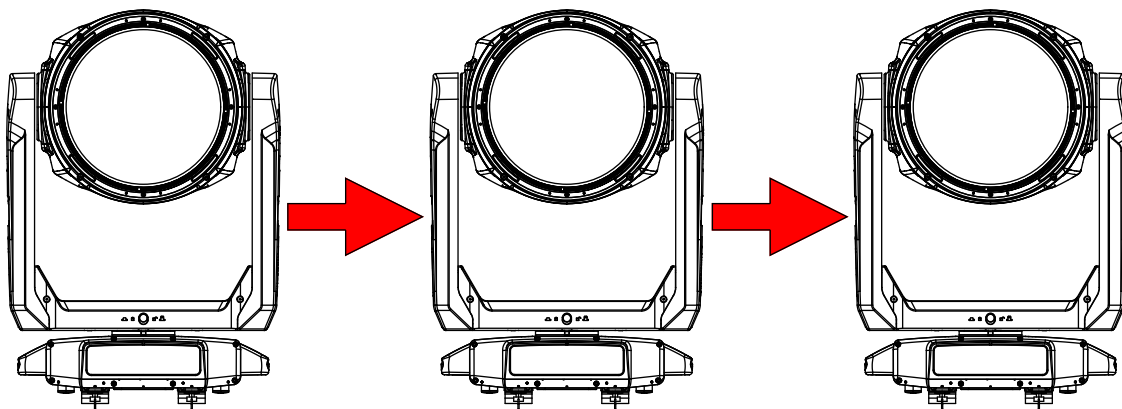

INSTALLATION GUIDELINES

POWER AND DATA CABLES



ENSURE ALL CONNECTIONS AND END-CAPS ARE PROPERLY SEALED WITH DIELECTRIC GREASE (AVAILABLE AT MOST ELECTRICAL SUPPLIERS) TO PREVENT WATER CORROSION AND/OR ELECTRICAL SHORT CIRCUIT.



TO MAINTAIN THE IP66 RATING INTEGRITY OF THE FIXTURE AND PREVENT WATER FROM ENTERING THE FIXTURE, SEAL ALL UNUSED CONNECTION RUBBER CAPS.

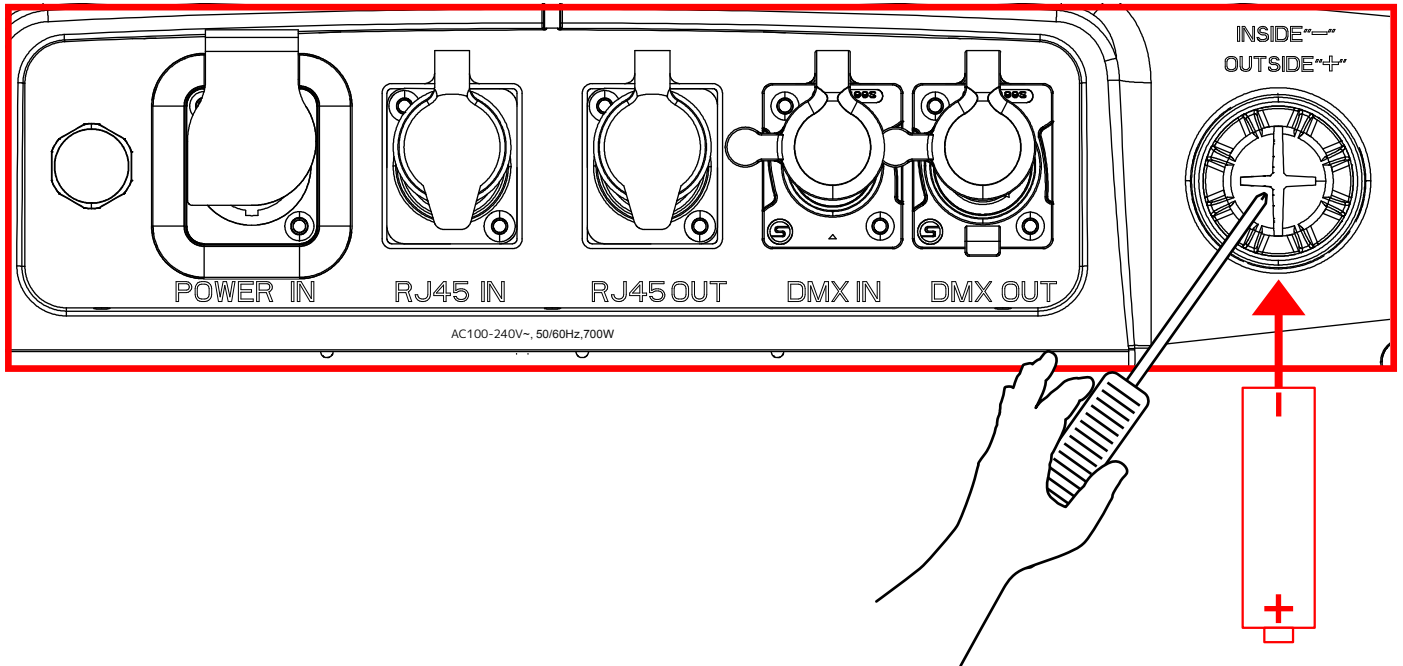

BATTERY REPLACEMENT



Installing the battery incorrectly, in the wrong orientation, where the Plus (+) is inside and Negative (-) is outside, will lead to internal electronics and battery damage. A qualified electrician should be used for all electrical connections and/or installations.

1. Loosen the screw cap for the battery compartment.
2. Remove old battery and replace (**inside "-"**, and **outside "+"**).

NOTE: Replace the battery only with an Li-ion battery (IRC14500/700mAh), which can be ordered from the Elation Parts Website <https://parts.elationlighting.com>. Replace and tighten screw cap for the battery compartment.

INSTALLATION GUIDELINES

POTENTIAL INTERNAL FIXTURE DAMAGE FROM EXTERNAL SOURCES OF LIGHT BEAMS

External sources of light beams from direct sunlight, lighting and moving head fixtures, and lasers, which are focused directly towards the exterior housing and/or penetrate the front lens opening of Elation lighting fixtures, can cause severe internal damage including burning of optics, dichroic color filters, glass and metal gobos, prisms, animation wheels, frost filters, iris, shutters, motors, belts, wiring, discharge lamps, and LEDs.

This issue is not specific only to Elation lighting fixtures, but rather it is a common issue with lighting fixtures from all manufacturers. Although there is no true way to fully prevent this issue from happening, the guidelines below can reduce the risk of potential damage. Contact Elation Service for more details.

DO NOT EXPOSE THE FIXTURE AND/OR FRONT LENS OPENING TO LIGHT BEAMS FROM DIRECT SUNLIGHT, OTHER LIGHTING OR MOVING HEAD FIXTURES, AND LASERS DURING UNPACKING, INSTALLATION, USE, AND EXTENDED IDLE TIMES OUTDOORS. DO NOT FOCUS A LIGHT BEAM FROM ONE LIGHTING FIXTURE DIRECTLY TOWARDS ANOTHER.

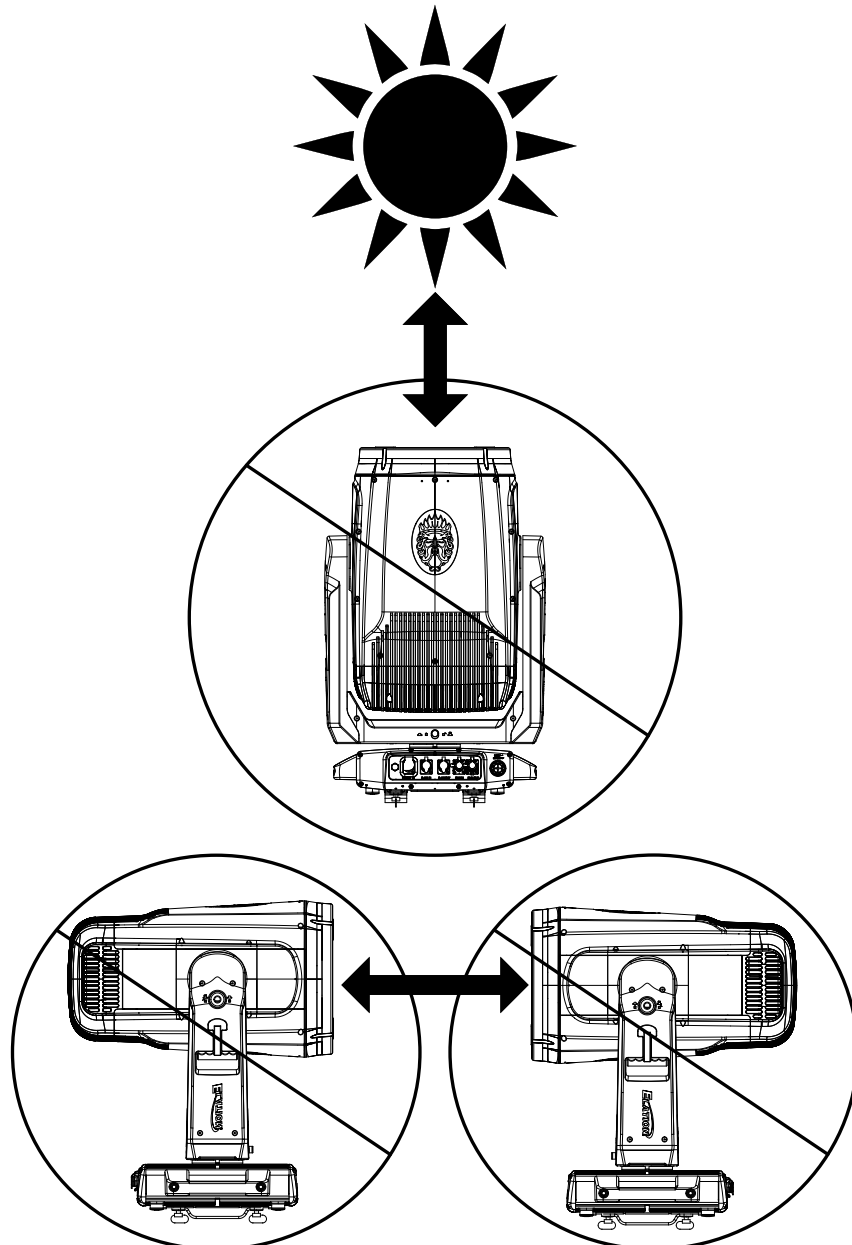

SUN PROTECTION MODE

The fixture incorporates an automatic protection from harmful sunlight, which can damage a fixture's internal components from extended exposure. Fixtures use an internal sensor to determine their physical orientation, then reorient the fixture towards the ground to prevent sunlight from entering the lens.

This automatic feature only works when the fixture is powered. If the fixture is unpowered during setup, it is necessary to manually reorient the lenses away from the sun, and aim them towards the ground. Even a few minutes of sun exposure can cause damage inside the fixture.

The Sun Protection setting is accessed via the "No DMX Status" menu.

The automatic sun protection positioning is activated under the following conditions:

1. Power on without DMX signal: the fixture always starts in sun protection mode.
2. No DMX Status "Sun Protection": the fixture enters sun protection mode after approximately 3 minutes.
3. Remote DMX control: the sun protection position can be **temporarily** activated from the lighting console without the need to create a custom position preset. The fixture senses the correct ground orientation. This means that fixtures already facing the ground may not move their heads.

Hold "Sun Protect Position" for 3s to set the fixture to the sun protection position.

Sun protection status displays as "**Sun Protection: Active**".

The sun protection position deactivates under the following conditions:

1. Connect DMX signal.
2. Remote DMX control: Hold "Sun Protection Off" for 3s.

To avoid harsh or jarring movements, the sun protection position always uses a 5-second fade time when it is activated or deactivated.

HIBERNATION MODE

To reduce wear on the fixture and its components, this mode disables motors and most electronics. Set the hibernation mode countdown time in the Display Menu: "Status Settings / Personality / Hibernation". Hibernation can be fully disabled.

The hibernation mode activates under the following conditions:

1. Loss of DMX: the fixture enters hibernation after the timeout expires. Default is 15 minutes.
2. Remote DMX control: Hold "Hibernate Fixture" for 3s

The hibernation mode deactivates under the following conditions:

1. Connect DMX Signal
2. Remote DMX control: Hold "Hibernate Off" for 3s

The fixture will perform a full calibration cycle, then assume the current DMX status.

Please note that the Hibernation does not change the PT position of the fixtures, allowing the user to set the desired position and then issue the Hibernate command.

To ensure the fixture is protected from harmful sunrays it is recommended to either leave the "No DMX Status" in "Sun Protection" (so the fixture is already in the correct position after 3 minutes of DMX loss) or set the fixture to a safe Tilt position manually first before hibernation.

Burn and heat damage to the fixture's interior components due to external light sources (sun or other fixtures shining into the lens) is never covered under the manufacturers warranty.

FAN MODES and LOW NOISE OPERATION

The Proteus Atlas is a high-performance fixture suited for multiple applications. For noise critical environments such as Theater, Opera or Orchestra Halls, it offers various fan operation modes which remove any distraction for the audience and performers. Fan Modes can be changed remotely via the DMX control channel, allowing the fixture to offer high output or whisper silent operation at a moment's notice. All Fan Modes smoothly transition over a brief time, preventing unwanted attraction to the fixture.

Auto (Default)—Fans only run at the speeds needed to keep the LED engine within a safe temperature range and ensures optimal performance of the fixture. If possible, they will turn-off, for example, when the fixture is dimmed to a low intensity. Fans sense the ambient and fixture temperature, and will always try to keep noise levels to a minimum. The fixture output will only reduce when the LED engine cannot be cooled down to its safe operating range due to high ambient temperature.

NOTE: Recommended for daily operation.

High—Fan speeds are increased throughout for the most efficient cooling of the fixture. This mode will increase wear on the fans and should only be utilized in exceptional circumstances. Fans will always run, even if the fixture is dimmed down. Fixture output is kept at 100% unless the LED engine temperature reaches an unsafe temperature at which point the fixture will reduce power carefully to ensure continued safe operation. This mode is only required in very high ambient temperatures when automatic fan speed adjustments are not desired.

Low Noise Mode

For very critical noise environments, the fixture offers two additional Low Noise Modes for silent operation. The fixture output will be reduced, yet due to the extremely high luminous flux, the fixture still offers outstanding performance. In Low Noise Modes, all parameters of the fixture operate more quietly with reduced fan speeds.

Low - 75-80% max output, fans run at low speed.

SYSTEM MENU

The fixture includes an easy to navigate system menu. The control panel (see image below) located on the front of the fixture, provides access to the main system menu and is where all necessary system adjustments are made to the fixture. During normal operation, pressing **ENTER** button once will access the fixture's main menu. Once in the main menu you can navigate through the different functions and access the submenus with the **UP** and **DOWN** buttons. Once you reach a field that requires adjusting, press the **ENTER** button to activate that field and use the UP and **DOWN** buttons to adjust the field. Pressing the **ENTER** button once more will confirm your setting. You may exit the main menu at any time without making any adjustments by pressing the **ENTER** button.

Display Shortcuts:

Power Off: Long press the **ENTER** button for 3s, activate battery mode

Power On: Long press the **ENTER** button for 10s, unlock display, show 10s countdown

Long press the **UP** button and the **DOWN** button for 3s, disable Pan Tilt

Long press the **BACK** button and the **ENTER** button for 5s, Countdown 10 sec or Reset to Default.

NOTE: To access the LCD Menu Control Display via the internal battery, press and hold the **MODE/ESC** button for 10 seconds. The LCD Menu Control Display will shut **OFF** automatically about 1 minute from the last button press.

PERMANENT INSTALLATION SETTING AND PHANTOM TOUCH

A phantom touch on an LCD screen is an unexpected, unprompted touch that seems to occur without any physical contact, like a raindrop. When installing any fixture in a permanent setting, we recommend setting your display to lock after 10-seconds and not the **OFF** setting. Units in a permanent setting are exposed to various conditions, if a unit is set to **OFF**, the display may interpret a raindrop as a command and change the fixture's setting through a phantom touch. Setting the display to lock after 10-seconds, and not setting the display to **OFF**, prevents this scenario.

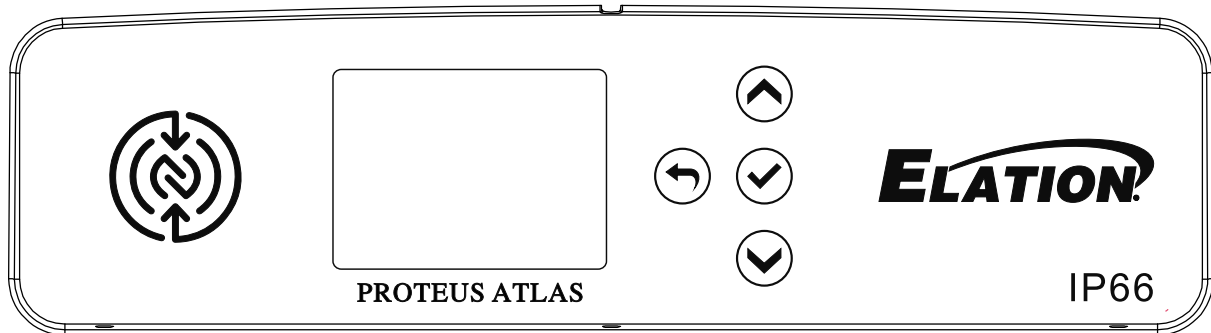

BATTERY

This unit features a dedicated battery that can be used to power the screen display. This allows the user to configure the device's channel mode, DMX address, or any other screen-accessible features without needing to power on the device or even connect it to a power source. To activate the display on battery power, press and hold the **ENTER** button for 3 seconds.

ALTHOUGH ARIA SETTINGS MAY APPEAR IN THE SYSTEM MENU, THIS FEATURE IS NOT ACTIVATED. ARIA WIRELESS DMX IS AN OPTIONAL FEATURE WHICH MUST BE ACTIVATED IN THE SERVICE MENU. PLEASE CONTACT ELATION SERVICE FOR FURTHER DETAILS.



AN ELATION E-LOADER III CAN BE USED TO UPDATE THE FIXTURE TO THE LATEST SOFTWARE. TO ORDER THIS DEVICE, PLEASE CONTACT ELATION SUPPORT FOR FURTHER DETAILS.

**ELATION SERVICE USA - Monday - Friday 8:00am to 4:30pm PST
323-582-3322 | support@elationlighting.com**

**ELATION SERVICE EUROPE - Monday - Friday 08:30 to 17:00 CET
+31 45 546 85 63 | support@elationlighting.eu**

SYSTEM MENU

MAIN MENU	OPTIONS / VALUES (Default Settings in BOLD)		
DMX Settings	DMX Address	001 - 512	
	DMX Mode	Standard, Extended	
	No DMX Status	Hold Last , Fade to Black, Sun Protection	
		Hibernation	Off, 1-99M (Default = 15 Min)
	Protocol	Select Signal	DMX / Art-Net / sACN / Aria In-DMX Out / DMX In - Aria Out
		Universe	1
		DHCP	Off /On
		IP Address	2.x.x.x
Subnet Mask		255.0.0.0	
Ethernet DMX Out	Off /On		
Aria	Aria Channel	0 -14	
Control	Manual Control	Dimmer 0% - 100%	
		Pan	
		Tilt	
		...	
Reset	All, Pan Tilt, Color, Gobo, FocusZoom, Others		
Self Test	All, Dimmer, Movement, Color Mix, Gobo, Beam		
Settings	Movement	Pan Invert	Off /On
		Tilt Invert	Off /On
		Pan Tilt Speed	Smooth/ Fast
		Pan Tilt Brake	Smooth/ Fast
		Pan Degree	540 /360/360 Short
		Pan Path	Short/ Continue
	Pan Tilt Feedback	Off/ On	
	Fans Control	Auto , High, Low	
	Color	CMY Speed	Smooth/ Fast
	Dimmer Curve	Linear, Square, Square Inverse, S-Curve	
Display	Screen Delay	10s - 5min (Default = 1 min)	
	Screen Lock	Off , 10s - 5 min	
	Auto Rotate	Off/ On	
Reset Defaults	Yes / No		
Information	Time	Current Time, Total Run Time, Last Run Time	
	Temperature	Head, Base, Lamp	
	Humidity	Head, Base	
	Fan	Fan 1U (Position), ...	
	DMX Values	Pan, Tilt, ...	
	Product IDs	RDM UID, Product SN, LED SN	
	Error Logs	Fixture Errors	
	Software Version	Vx.x	
Service (Passcode 50)	Vent Clean	Off /On	
	Calibration	Dimmer, Pan, Tilt, ...	
	Reset Last Run	Yes / No	
	Reset Error Logs	Yes / No	

Display Shortcuts

Power Off

ENTER (3s)	Activate battery mode
------------	-----------------------

Power On

Enter (10s)	Unlock display, show 10s countdown
Up+Down (3s)	Disable Pan Tilt
Back + Enter (5s)	Countdown 10 sec
	Reset to Default (No/Yes)

DIMMER MODES AND DIMMER CURVES

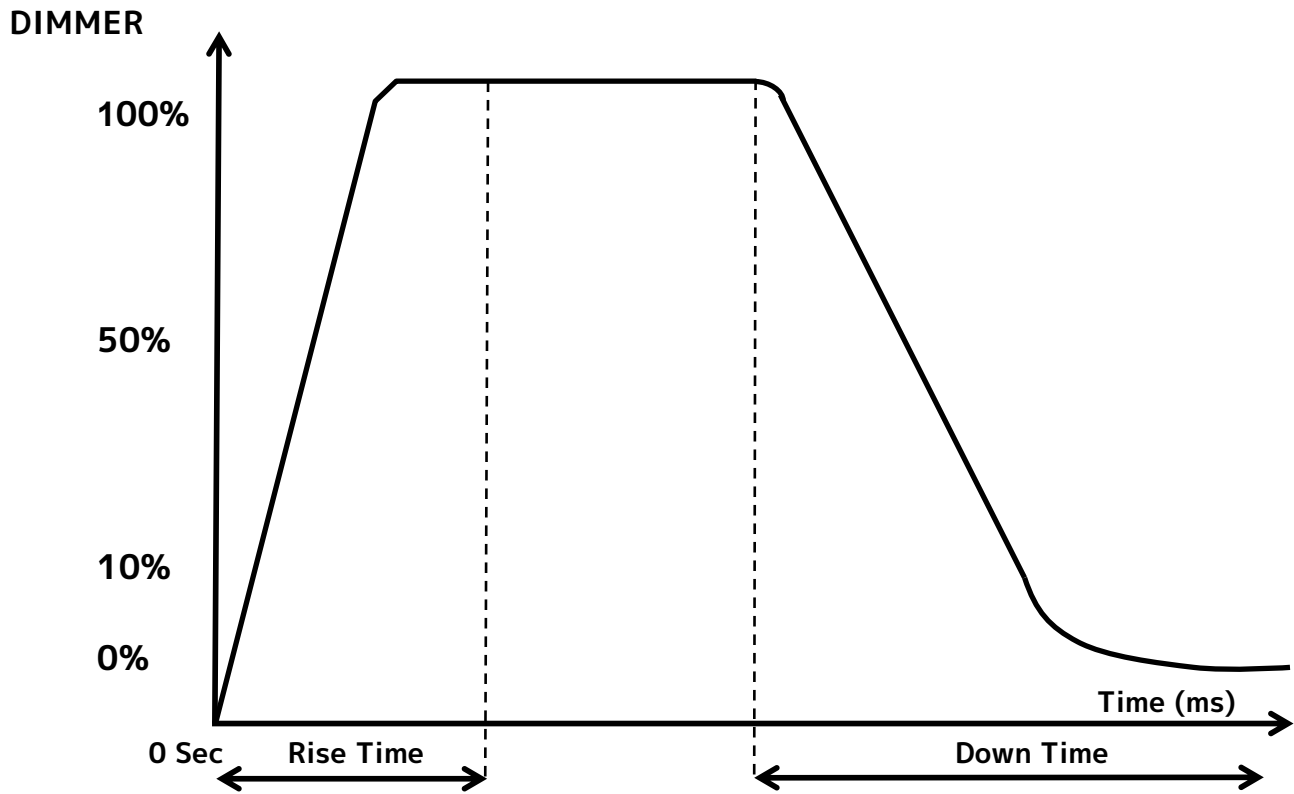

Dimming Curve Ramp Effect	0 sec Fade Time		1 sec Fade Time	
	Rise Time (ms)	Down Time (ms)	Rise Time (ms)	Down Time (ms)
Standard (default)	0	0	0	0
Stage	780	1100	1540	1660
TV	1180	1520	1860	1940
Architectural	1380	1730	2040	2120
Theatre	1580	1940	2230	2280
Stage 2	0	1100	0	1660

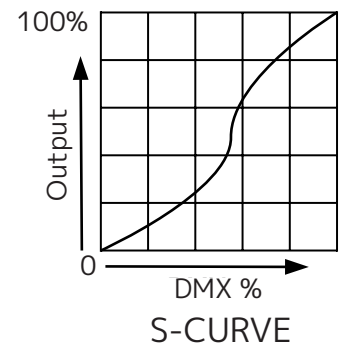
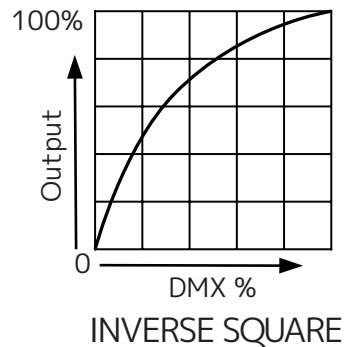
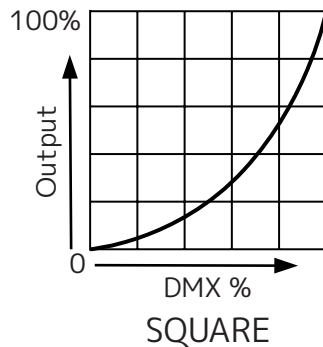
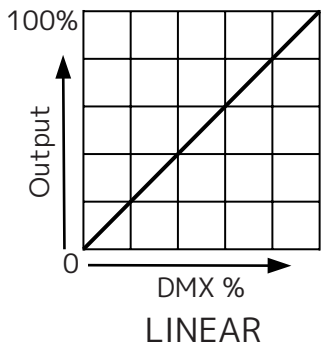

DMX TRAITS

Standard	Extended	Value	Function
1	1	0-255	Pan Left → Right
2	2	0-255	Pan Fine Fine Position
3	3	0-255	Tilt Forward → Backward
4	4	0-255	Tilt Fine Fine Position
5	5		Pan Rotate
		0 – 2	Disabled
		3 – 126	Rotating Clockwise Fast → Slow
		127 – 129	No rotation (Fixture stops at its current position)
		130 – 253	Rotating Counter-Clockwise Fast → Slow
		254 – 255	No rotation (Fixture stops at its current position)
6	6	0-255	Cyan 0 → 100%
	7	0-255	Cyan Fine Fine Saturation
7	8	0-255	Magenta 0 → 100%
	9	0-255	Magenta Fine Fine Saturation
8	10	0-255	Yellow 0 → 100%
	11	0-255	Yellow Fine Fine Saturation
9	12		Color
		0-2	Open
		3-7	Color 1
		8-12	Color 2
		13-17	Color 3
		18-22	Color 4
		23-27	Color 5
		28-32	Color 6
		33-37	Color 7
		38-42	Color 8
		43-47	Color 9
		48-52	Color 10
		53-57	Color 11
		58-62	Color 12
		63-67	Color 13
		68-72	Color 14
		73-77	Color 15
		78-82	Color 16
		83-87	Color 17
		88-92	Color 18
		93-97	Color 19
		98-102	Color 20
		103-107	Color 21
		108-112	Color 22
		113-117	Color 23
		118-122	Color 24
		123-127	Color 25
			Scroll
		128-189	Clockwise Fast → Slow
		190-193	Stop
		194-255	Counter-clockwise Slow → Fast

DMX TRAITS

Standard	Extended	Value	Function		
	13	0-255	Color Fine Position		
10	14		Rotating Gobo		
		0-7	Open		
		8-14	Rotating Gobo 1		
		15-21	Rotating Gobo 2		
		22-28	Rotating Gobo 3		
		29-35	Rotating Gobo 4		
		36-42	Rotating Gobo 5		
		43-49	Rotating Gobo 6		
		50-56	Rotating Gobo 7		
		57-63	Rotating Gobo 8		
		64-70	Rotating Gobo 9		
		71-77	Rotating Gobo 10		
		78-84	Rotating Gobo 11		
		85-91	Rotating Gobo 12		
		92-98	Rotating Gobo 13		
		99-105	Gobo 1 Shake Slow → Fast		
		106-112	Gobo 2 Shake Slow → Fast		
		113-119	Gobo 3 Shake Slow → Fast		
		120-126	Gobo 4 Shake Slow → Fast		
		127-133	Gobo 5 Shake Slow → Fast		
		134-140	Gobo 6 Shake Slow → Fast		
		141-147	Gobo 7 Shake Slow → Fast		
		148-154	Gobo 8 Shake Slow → Fast		
		155-161	Gobo 9 Shake Slow → Fast		
		162-168	Gobo 10 Shake Slow → Fast		
		169-175	Gobo 11 Shake Slow → Fast		
		176-182	Gobo 12 Shake Slow → Fast		
		183-189	Gobo 13 Shake Slow → Fast		
					Scroll
				190-221	Clockwise Fast → Slow
		222-223	Stop		
		224-255	Counter-clockwise Slow → Fast		
11	15		Rotating Gobo Index/ Rotation		
		0-127	Index Position		
			Rotate		
		128-189	Clockwise Fast → Slow		
		190-193	Stop		
		194-255	Counter-clockwise Slow → Fast		
12	16	0-255	Rotating gobo fine indexing:		
			Fine indexing		

DMX TRAITS

Standard	Extended	Value	Function
13	17		Fixed gobo
		0-45	Open
		46-48	Gobo 1
		49-51	Gobo 2
		52-54	Gobo 3
		55-57	Gobo 4
		58-60	Gobo 5
		61-63	Gobo 6
		64-66	Gobo 7
		67-69	Gobo 8
		70-72	Gobo 9
		73-75	Gobo 10
		76-78	Gobo 11
		79-81	Gobo 12
		82-84	Gobo 13
		85-87	Gobo 14
		88-90	Gobo 15
		91-93	Gobo 16
		94-96	Gobo 17
		97-99	Gobo 18
		100-102	Gobo 19
		103-105	Gobo 20
		106-108	Gobo 21
		109-111	Gobo 22
		112-114	Gobo 23
		115-117	Gobo 24
		118-120	Gobo 1 shake slow to fast
		121-123	Gobo 2 shake slow to fast
		124-126	Gobo 3 shake slow to fast
		127-129	Gobo 4 shake slow to fast
		130-132	Gobo 5 shake slow to fast
		133-135	Gobo 6 shake slow to fast
		136-138	Gobo 7 shake slow to fast
		139-141	Gobo 8 shake slow to fast
		142-144	Gobo 9 shake slow to fast
		145-147	Gobo 10 shake slow to fast
		148-150	Gobo 11 shake slow to fast
		151-153	Gobo 12 shake slow to fast
		154-156	Gobo 13 shake slow to fast
		157-159	Gobo 14 shake slow to fast
		160-162	Gobo 15 shake slow to fast
163-165	Gobo 16 shake slow to fast		
166-168	Gobo 17 shake slow to fast		
169-171	Gobo 18 shake slow to fast		
172-174	Gobo 19 shake slow to fast		
175-177	Gobo 20 shake slow to fast		
178-180	Gobo 21 shake slow to fast		
181-183	Gobo 22 shake slow to fast		
184-186	Gobo 23 shake slow to fast		
187-189	Gobo 24 shake slow to fast		
			Scroll
		190-221	Clockwise Fast → Slow
		222-223	Stop
		224-255	Counter-clockwise Slow → Fast

DMX TRAITS

Standard	Extended	Value	Function
	18	0-255	Fixed gobo indexing Fine: Fine indexing
14	19		Rotating Prism 1
		0-15	Open
		16-75	4 Facet
		76-135	16 Facet
		136-195	6 Facet Linear
		196-255	Open
15	20		Rotating Prism 1 Index/Rotation
		0-127	Index Position
			Rotate
		128-189	Clockwise Fast → Slow
		190-193	Stop
		194-255	Counter-clockwise Slow → Fast
	21	0-255	Rotating Prism 1 Index/Rotation Fine Position
16	22		Rotating Prism 2
		0-15	Open
		16-75	4 Facet Linear
		76-135	5 Facet
		136-195	8+8 Facet
		196-255	Open
17	23		Rotating Prism 2 Index/Rotation
		0-127	Index Position
			Rotate
		128-189	Clockwise Fast → Slow
		190-193	Stop
		194-255	Counter-clockwise Slow → Fast
	24	0-255	Rotating Prism 2 Index/Rotation Fine Position
18	25	0 - 255	Frost 1 (Soft) Open → Max
19	26	0 - 255	Frost 2 (Wash) Open → Max
20	27	0-255	Focus Infinity → Near
21	28	0-255	Focus Fine Fine Adjustment
22	29	0-255	Zoom Narrow → Wide
23	30	0-255	Zoom Fine Fine Adjustment
24	31		Shutter/Strobe
		0-31	Closed
		32-63	Open
		64-95	Strobe Slow → Fast
		96-127	Open
		128-159	Pulse-effect
		160-191	Open
		192-223	Random strobe Slow → Fast
224-255	Open		

DMX TRAITS

Standard	Extended	Value	Function
25	32	0-255	Dimmer
			Intensity 0 → 100%
26	33	0-255	Dimmer Fine
			Fine Adjustment
	34		Dim Modes
		0-20	Standard
		21-40	Stage
		41-60	TV
		61-80	Architectural
		81-100	Theatre
		101-120	Stage 2
			Dimmer Delay Time
		121	0s
		122	0.1s
		123	0.2s
		124	0.3s
		125	0.4s
		126	0.5s
		127	0.6s
		128	0.7s
		129	0.8s
		130	0.9s
		131	1.0s
		132	1.5s
		133	2.0s
		134	3.0s
		135	4.0s
		136	5.0s
		137	6.0s
		138	7.0s
		139	8.0s
		140	9.0s
		141	10s
		142-255	Idle
	35		Color Macro Speed
		0-255	Max → Min Speed

DMX TRAITS

Standard	Extended	Value	Function
	36		Color Macros
		0-31	OFF
		32-39	Macro1
		40-47	Macro2
		48-55	Macro3
		56-63	Macro4
		64-71	Macro5
		72-79	Macro6
		80-87	Macro7
		88-95	Macro8
		96-103	Macro9
		104-111	Macro10
		112-119	Macro11
		120-127	Macro12
		128-135	Macro13
		136-143	Macro14
		144-151	Macro15
		152-159	Macro16
		160-167	Macro17
		168-175	Macro18
		176-183	Macro19
		184-191	Macro20
		192-199	Macro21
		200-207	Macro22
		208-215	Macro23
		216-223	Macro24
		224-231	Macro25
232-239	Macro26		
240-247	Macro27		
248-255	Random CMY		
	37		Pan / Tilt Speed:
		0-225	Max → Min Speed
		226-235	Blackout by movement
		236-245	Blackout by wheel changes
		246-255	No function
27	38		Control
		0-10	Idle
		11-12	Color change normal
		13-14	Color change to any position
		15-16	Color & gobo change to any position
			Fan
		17-18	Low
		19-20	High
		21-22	Auto
			Motion
		23-24	Pan Tilt Smooth
		25-26	Pan Tilt Fast
		27-28	Pan Tilt Break Smooth
		29-30	Pan Tilt Break Fast
		31-32	Pan Shortest Path
		33-34	Pan Continue Path
		35-36	Pan Range 540
		37-38	Pan Range 360
39-40	Pan Range 360 Short		
41-79	Idle		

DMX TRAITS

Standard	Extended	Value	Function
27	38		Reset
		80-84	Fixture
		85-87	Pan Tilt
		88-90	Color
		91-93	Gobo
		94-96	Beam
		97-99	Other Features
			Refresh Rate (Hz)
		100	900
		101	910
		102	920
		103	930
		104	940
		105	950
		106	960
		107	970
		108	980
		109	990
		110	1000
		111	1010
		112	1020
		113	1030
		114	1040
		115	1050
		116	1060
		117	1070
		118	1080
		119	1090
		120	1100
		121	1110
		122	1120
		123	1130
		124	1140
		125	1150
		126	1160
		127	1170
		128	1180
		129	1190
		130	1200
131	1210		
132	1220		
133	1230		
134	1240		
135	1250		
136	1260		
137	1270		
138	1280		
139	1290		

DMX TRAITS

Standard	Extended	Value	Function
26	36	140	1300
		141	1310
		142	1320
		143	1330
		144	1340
		145	1350
		146	1360
		147	1370
		148	1380
		149	1390
		150	1400
		151	1410
		152	1420
		153	1430
		154	1440
		155	1450
		156	1460
		157	1470
		158	1480
		159	1490
		160	1500
		161	2500
		162	4000
		163	5000
		164	6000
		165	10000
		166	15000
		167	20000
		168	25000
		169-170	Vent Cleaning On
		171-172	Vent Cleaning Off
		173-174	Hibernation Off
		175-176	Hibernation
		177-178	Sun Protection On
		179-180	Sun Protection Off
		181-200	Idle
	Dimmer Curve		
201-210	Linear		
211-220	Square		
221-230	Inverse Square		
231-240	S-Curve		
241-249	Idle		
250-251	Display Off		
252-253	Display On		
254-255	Idle		

REMOTE DEVICE MANAGEMENT (RDM)

NOTE: In order for RDM to work properly, RDM enabled equipment must be used throughout the entire system, including DMX data splitters and wireless systems.

Remote Device Management (RDM) is a protocol that sits on top of the DMX512 data standard for lighting, allowing the DMX systems of the fixtures to be modified and monitored remotely. This protocol is ideal for instances in which a unit is installed in a location that is not easily accessible.

With RDM, the DMX512 system becomes bi-directional, allowing a compatible RDM enabled controller to send out a signal to devices on the wire, as well as allowing the fixture to respond (known as a GET command). The controller can then use its SET command to modify settings that would typically have to be changed or viewed directly via the unit's display screen, including the DMX Address, DMX Channel Mode, and Temperature Sensors.

FIXTURE RDM INFORMATION:

RDM Code	Device ID	Device Model ID	Personality ID
0x22A6	Open	0x71E	Standard Mode (1) Extended Mode (2)

Please be aware that not all RDM devices support all RDM features, and therefore it is important to check beforehand to ensure that the equipment that you are considering includes all of the features that you require.

The following parameters are accessible in RDM on this device:

[0x0200] Sensor Definition
[0x0201] Sensor Value
[0x0080] Device Model Description
[0x0081] Manufacturer Label
[0x0082] Device Label
[0x00E0] DMX Personality
[0x00E1] DMX Personality Description
[0x0400] Device Hours
[0x0600] Pan Invert
[0x0601] Tilt Invert
[0x0500] Display Invert

ERROR CODES

When power is applied, the unit will automatically enter a "Reset/Test" mode. This mode brings all the internal motors to a home position. If there is an internal problem with one or more of the motors an error code will flash in the display in the form of "XXer" where as XX will represent a function number. For example, when the display shows "0Er" it means there is some type of error with the Pan motor. If there are multiple errors during the start-up process they will all flash in the display. For example: if the fixtures has errors on Channel 1, 2, and 5 all at the same time, you will see the error message "01Er", "02Er", and "05Er" flash repeated 5 times.

If an error does occur during the initial start-up procedure the fixture will self-generate a second reset signal and try to realign all the motors and correct the errors. If the error persists after a second attempt a third attempt will be made. If after a third attempt all the errors have not been corrected the fixture will make the following determinations:

- 3 or More Errors: The fixture cannot function properly with three or more errors therefore the fixture will place itself in a stand-by mode until subsequent repairs can be made.
- Less Than 3 Errors: The fixture has less than 3 errors; therefore, most other functions will work properly. The fixture will attempt to operate normally until the errors can be correct by a technician. The errors in question will remain flashing in the display as a reminder of internal errors.

Note: Error Codes are subject to change without any prior written notice.

ERROR CODES	DESCRIPTION
LED Temp Error	Led thermal sensor abnormal- cannot be detected or can be broken
Base Temp Error	Base thermal sensor abnormal- cannot be detected or can be broken
Base Fan1 Error	Base Fan1 Error
Base Fan2 Error	Base Fan2 Error
Base Fan3 Error	Base Fan3 Error
Base Fan4 Error	Base Fan4 Error
7UHeadFan1 Error	7UHeadFan1 Error
8UHeadFan1 Error	8UHeadFan1 Error
8UHeadFan2 Error	8UHeadFan2 Error
9HeadFan1 Error	9HeadFan1 Error
2U01 Com Fail	2U01 PCB communication Fail
3U01 Com Fail	3U01 PCB communication Fail
4U01 Com Fail	4U01 PCB communication Fail
5U01 Com Fail	5U01 PCB communication Fail
6U01 Com Fail,	6U01 PCB communication Fail,
7U01 Com Fail	7U01 PCB communication Fail
8U01 Com Fail	8U01 PCB communication Fail
9U01 Com Fail	9U01 PCB communication Fail
Base HD Higher	Base humidity >=85%

SOFTWARE UPDATES

E-LOADER III



**ONLY QUALIFIED TECHNICIANS SHOULD PERFORM THIS FUNCTION!
NOTE ALL MENU SETTINGS BEFORE UPDATING SOFTWARE!
FIXTURE SOFTWARE CAN NOT BE DOWNGRADED!
DOWNLOAD FIXTURE SOFTWARE TO PC ONLY! (NO MAC SUPPORT)
PLEASE CONTACT ELATION SERVICE FOR FURTHER INFORMATION.**

An Elation E-Loader III can be used to update the fixture to the latest software. Please visit the E-Loader III product page at the Elation web site and download the product manual for step by step instructions.

<https://www.elationlighting.com/e-loader-iii-software-uploader>

To order the E-Loader III uploader and the updated software for your fixture, please contact Elation support for details.

SOFTWARE UPDATES

ETHERNET UPDATER

Software updates for this fixture can be performed using the Elation Ethernet Updater. Contact Elation Service to obtain this updater device:

ELATION SERVICE USA - Monday - Friday 8:00am to 4:30pm PST
323-582-3322 | support@elationlighting.com

ELATION SERVICE EUROPE - Monday - Friday 08:30 to 17:00 CET
+31 45 546 85 63 | support@elationlighting.eu

The Elation Ethernet Updater is an EXE file, which only works on a PC System. Once you've received the Elation Ethernet Updater RAR file from Elation Service via email, download and extract the EXE file. With the file extracted, click Elation Ethernet Updater setupV100.exe to launch the installation wizard.



Follow the prompts once the Elation Ethernet Updater EXE has launched the Setup Wizard.

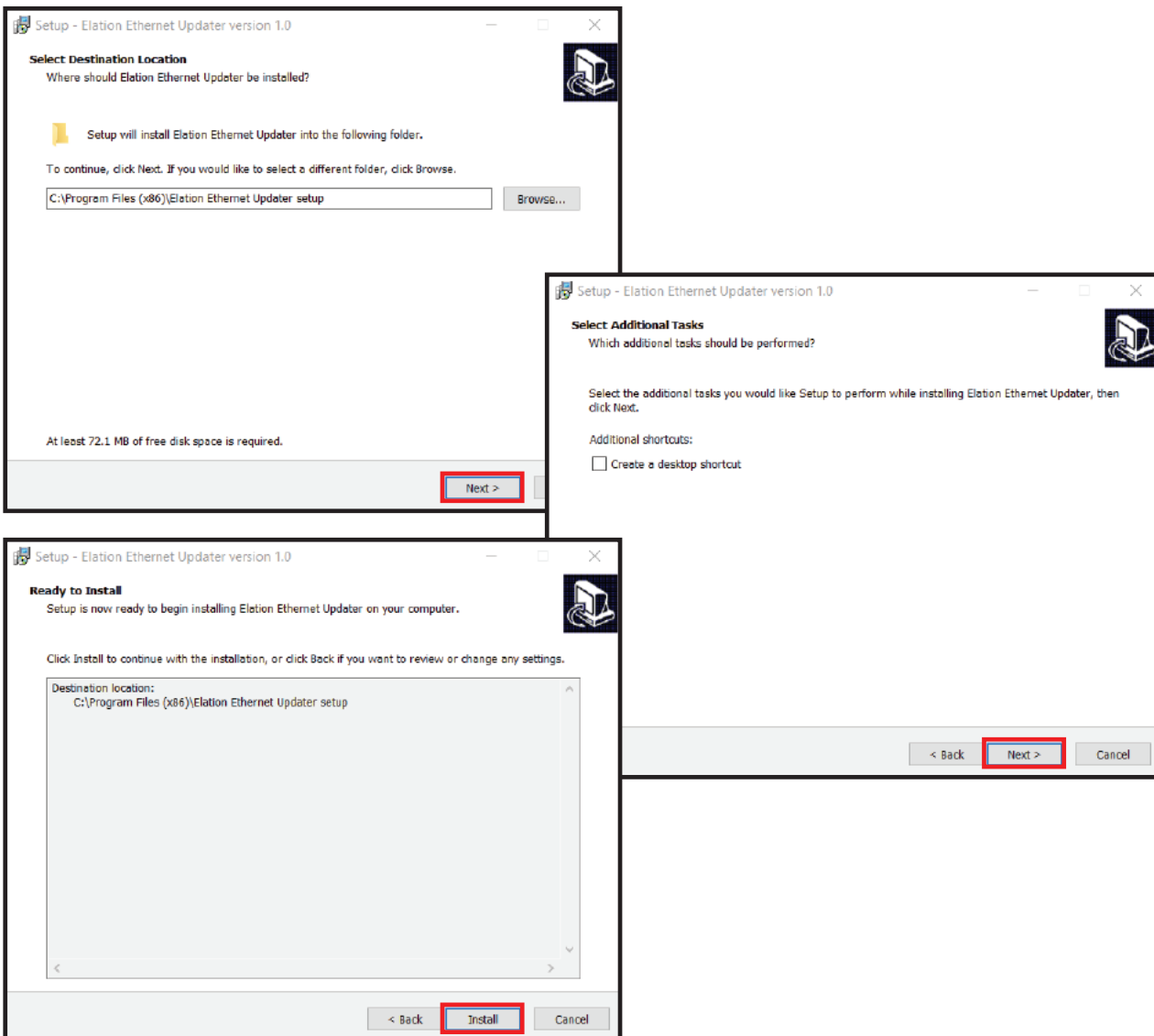

SOFTWARE UPDATES

ETHERNET UPDATER

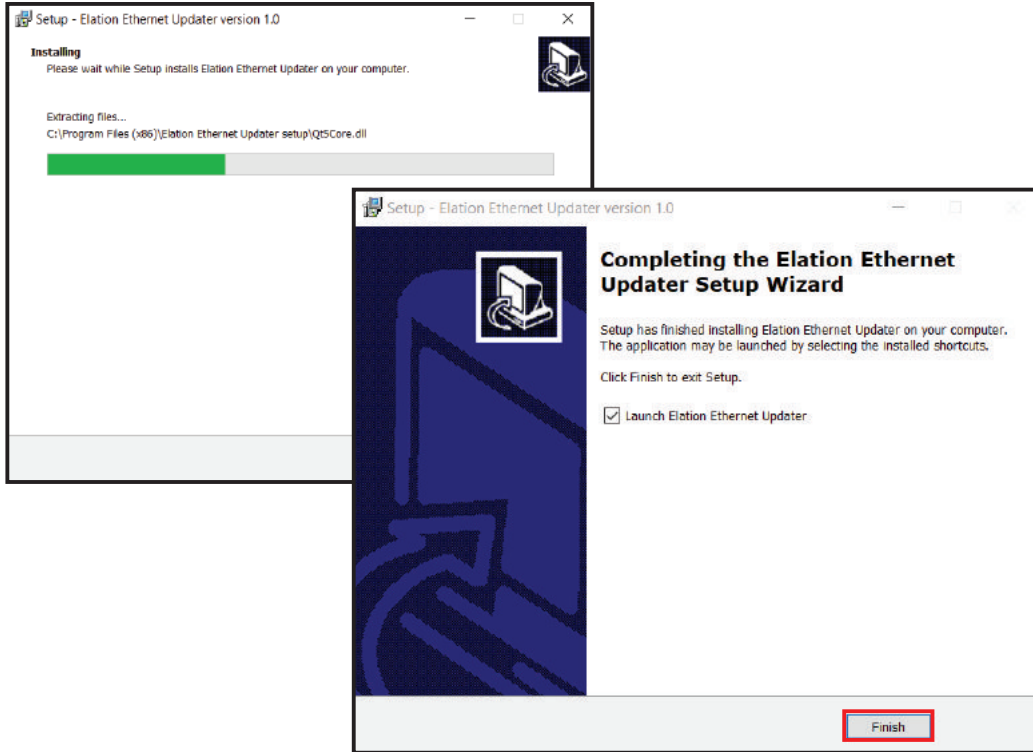

Once you have installed the Elation Ethernet Updater, it will launch automatically (unless you unchecked “Launch Elation Ethernet Updater”), or you can open it any time by clicking on the icon.

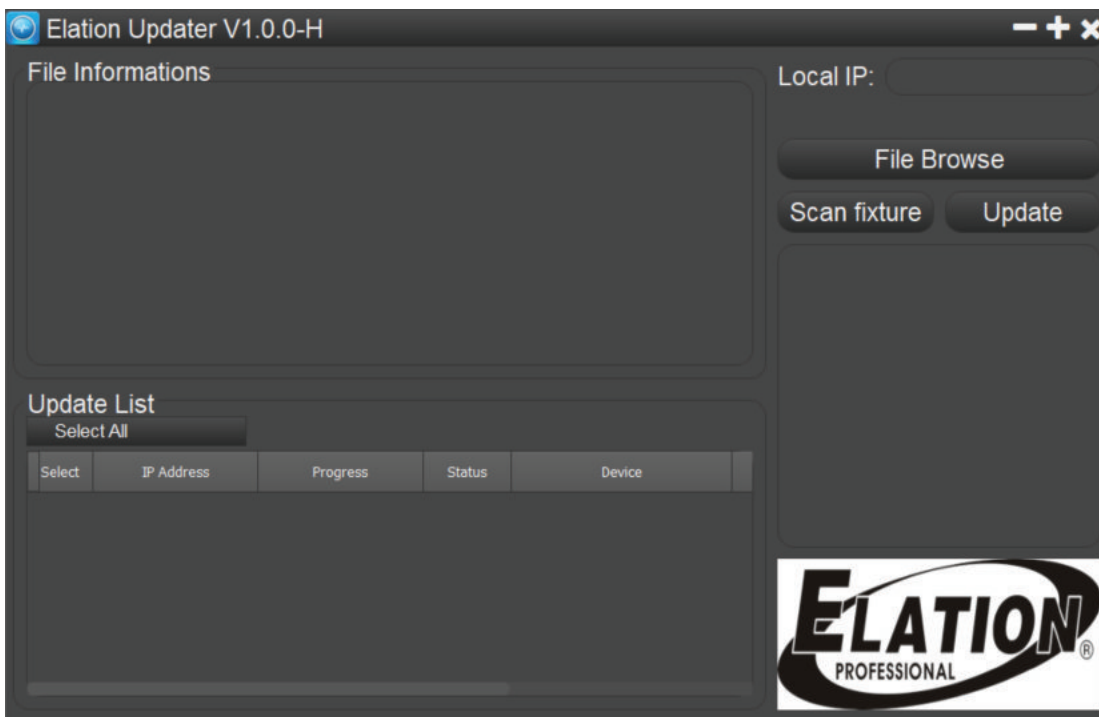

SOFTWARE UPDATES

ETHERNET UPDATER

Once opened, your local IP will automatically be identified. Click "Scan fixture" and create a connection. The fixture identity will appear in the Update List on the left side of browser. A connection will fail to establish if the fixture IP and Local IP are not in the same network segment.

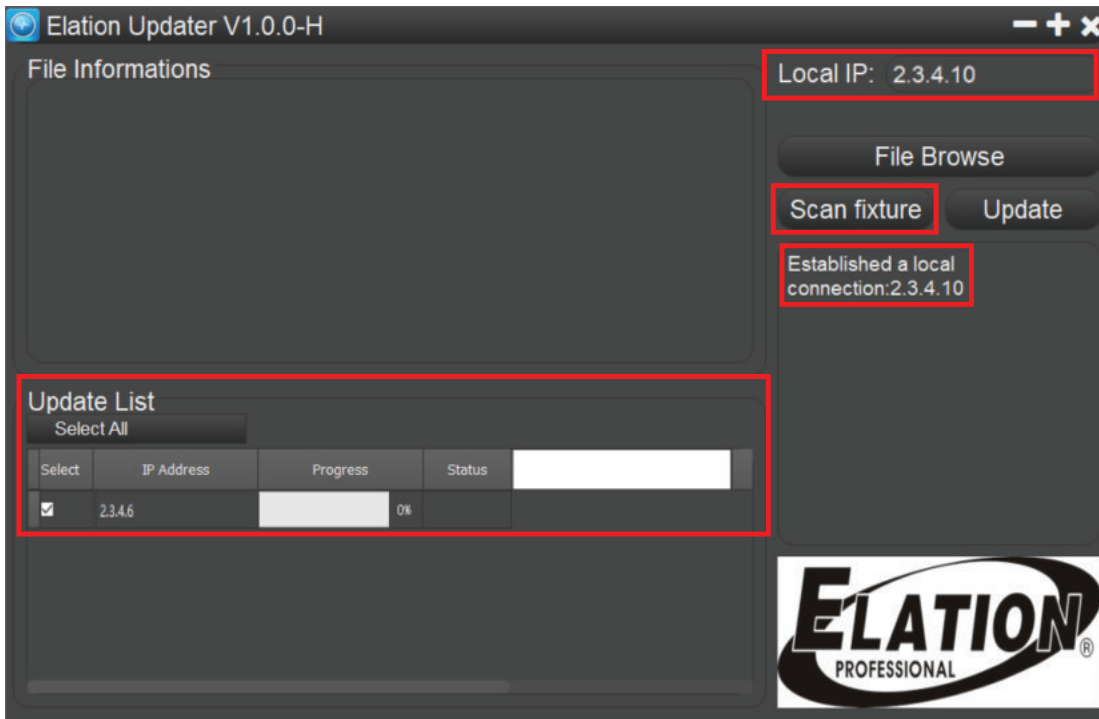

Click "File Browse" to select the files you want to download. The download Progress is displayed in the File information chart as a percentage bar graph.

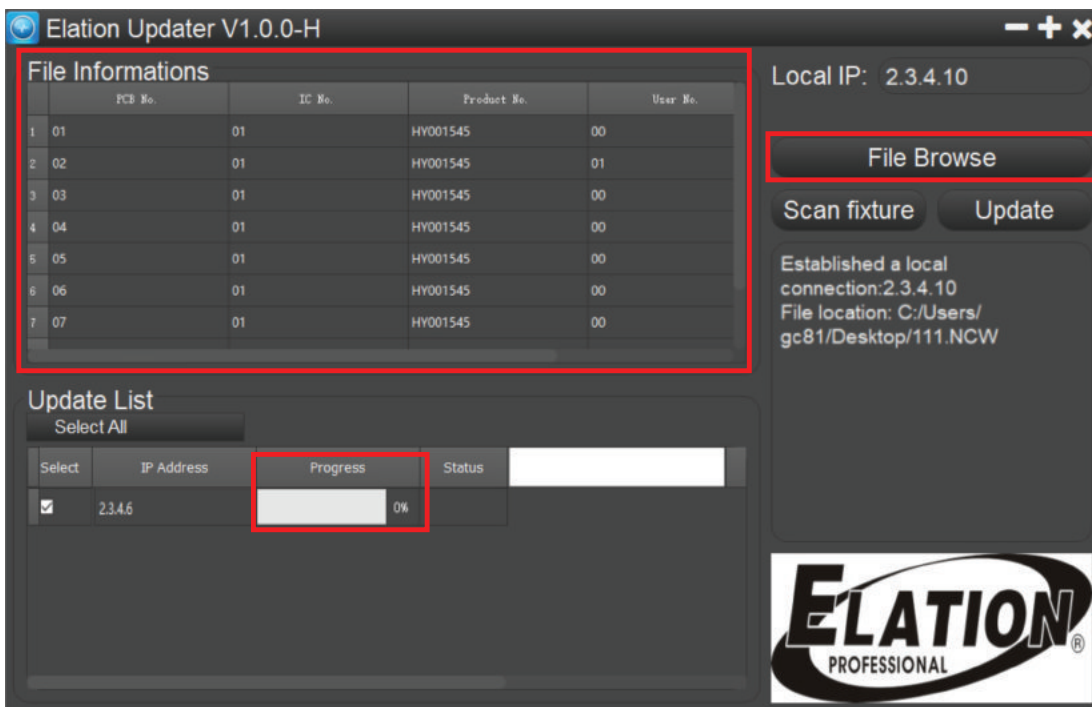

SOFTWARE UPDATES

ETHERNET UPDATER

Click Update, then wait for the download Progress to reach 100% before closing Updater. The Elation Ethernet Updater can update up to 31 fixtures via connection to a PC.

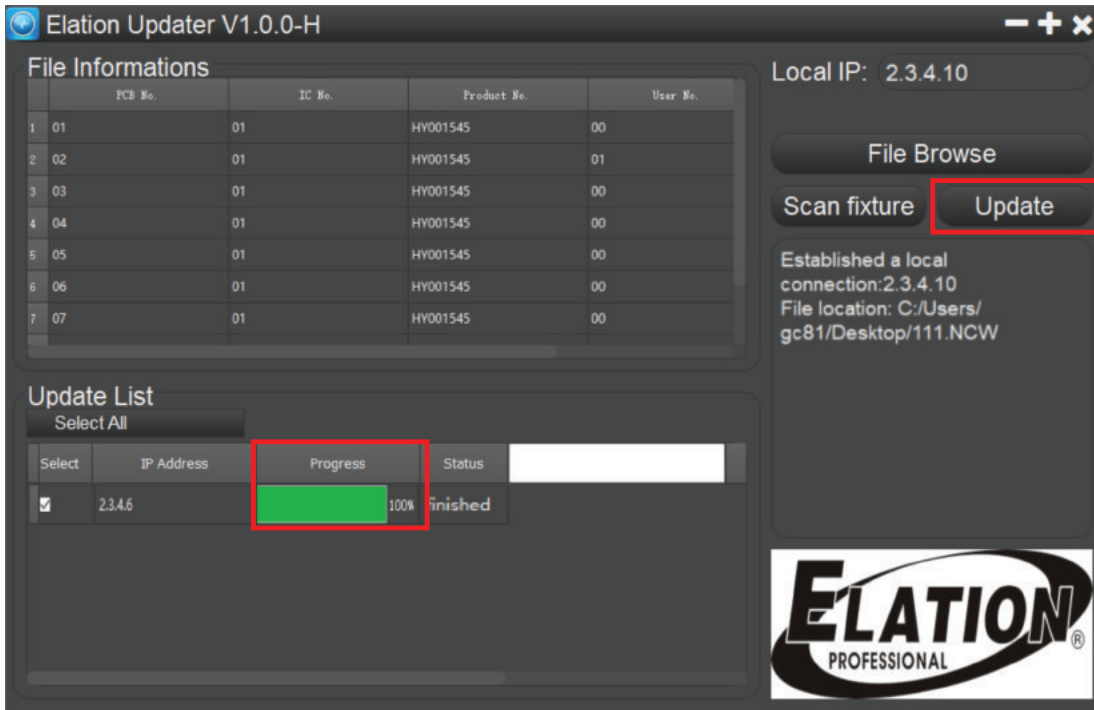

MAINTENANCE GUIDELINES



DISCONNECT POWER BEFORE PERFORMING ANY MAINTENANCE!

CLEANING

Frequent cleaning is recommended to ensure proper function, optimized light output, and an extended life. The frequency of cleaning depends on the environment in which the fixture operates: damp, smoky or particularly dirty environments can cause greater accumulation of dirt on the fixture's optics. Periodically clean the external lens surface with a soft cloth to avoid dirt/debris accumulation. **NEVER** use alcohol, solvents, or ammonia-based cleaners.

MAINTENANCE

Regular inspections are recommended to ensure proper function and extended life. There are no user serviceable parts inside this fixture. Please refer all other service issues to an authorized Elation service technician. Should you need any spare parts, please order genuine parts from your local Elation dealer.

Please refer to the following points during routine inspections:

- A detailed electric check by an approved electrical engineer every three months, to make sure the circuit contacts are in good condition and prevent overheating.
- Be sure all screws and fasteners are securely tightened at all times. Loose screws may fall out during normal operation, resulting in damage or injury as larger parts could fall.
- Check for any deformations on the housing, color lenses, rigging hardware, and rigging points (ceiling, suspension, trussing). Deformations in the housing could allow for dust to enter into the fixture. Damaged rigging points or unsecured rigging could cause the fixture to fall and seriously injure a person(s).
- Electric power supply cables must not show any damage, material fatigue or sediments. **NEVER** remove the ground prong from the power cable.

FIXTURE DISASSEMBLY

The following points should be observed after performing any maintenance procedure that requires disassembly of the unit:

- After the unit has been reassembled, open the valve and allow the unit to run for approximately 2 hours in order to dry out any moisture that has been trapped inside the fixture. The process should continue until indicated humidity drops below 15% for the head and 30% for the base.
- Once this has been achieved, the light can be switched off, but the unit should remain connected to power so that the cooling fan can cool down the unit. Please note that allowing cool down time should **ALWAYS** be done after lamp operation.
- Some units may require partial disassembly in order to gain access to the valve. Please contact Elation service for information regarding the location and access procedure for the valve on your specific unit model.

SPECIFICATIONS

SOURCE

500W Solid State Phosphor-Converted (SSPC) Light Engine
9000K, CRI 70
12,000 Hour Lamp Life

PHOTOMETRIC DATA

1.000.000 Lux @ 20m
100.000 Lux @ 100m
Beam Angle 0.6° - 8.5°

EFFECTS

Dual Frost (Hot- Spot Beam, Wash FX)
Ultra- Fast Zoom
Focus
2x3 Prisms on Dual Planes
Digital Shutter and Strobe
Pan Angle 360° / 540°
Tilt Angle 250°

COLOR

Full CMY Color Mixing System
25 Position Color Wheel

GOBOS

2 Gobo Wheels
13 Interchangeable-Rotating / Indexing Metal Gobos
26 Static-Stamped Metal Gobos

CONTROL / CONNECTIONS

2 DMX Channel Modes (26/36 Ch)
(6) Button Touch Panel
Full Color 180° Reversible LCD Menu Display
DMX, RDM, Art-Net and sACN Protocol Support
NFC Support
Ip65 5pin DMX In/Out
IP65 RJ45 Ethernet In/Out
IP65 Locking Power In

SIZE / WEIGHT (approx.)

Length: 15.0" (380.5mm)
Width: 20" (508mm)
Height: 31.5" (800mm)
Weight: 120.8 lbs. (54.8kg)

ELECTRICAL / THERMAL

AC 100-240V 50/60Hz
700W Max Power Consumption
-4°F to 113°F (-20°C to 45°C)

APPROVALS / RATINGS

CE | cETLus | UKCA | FCC | IP66

DIMENSIONAL DRAWINGS

DRAWINGS NOT TO SCALE

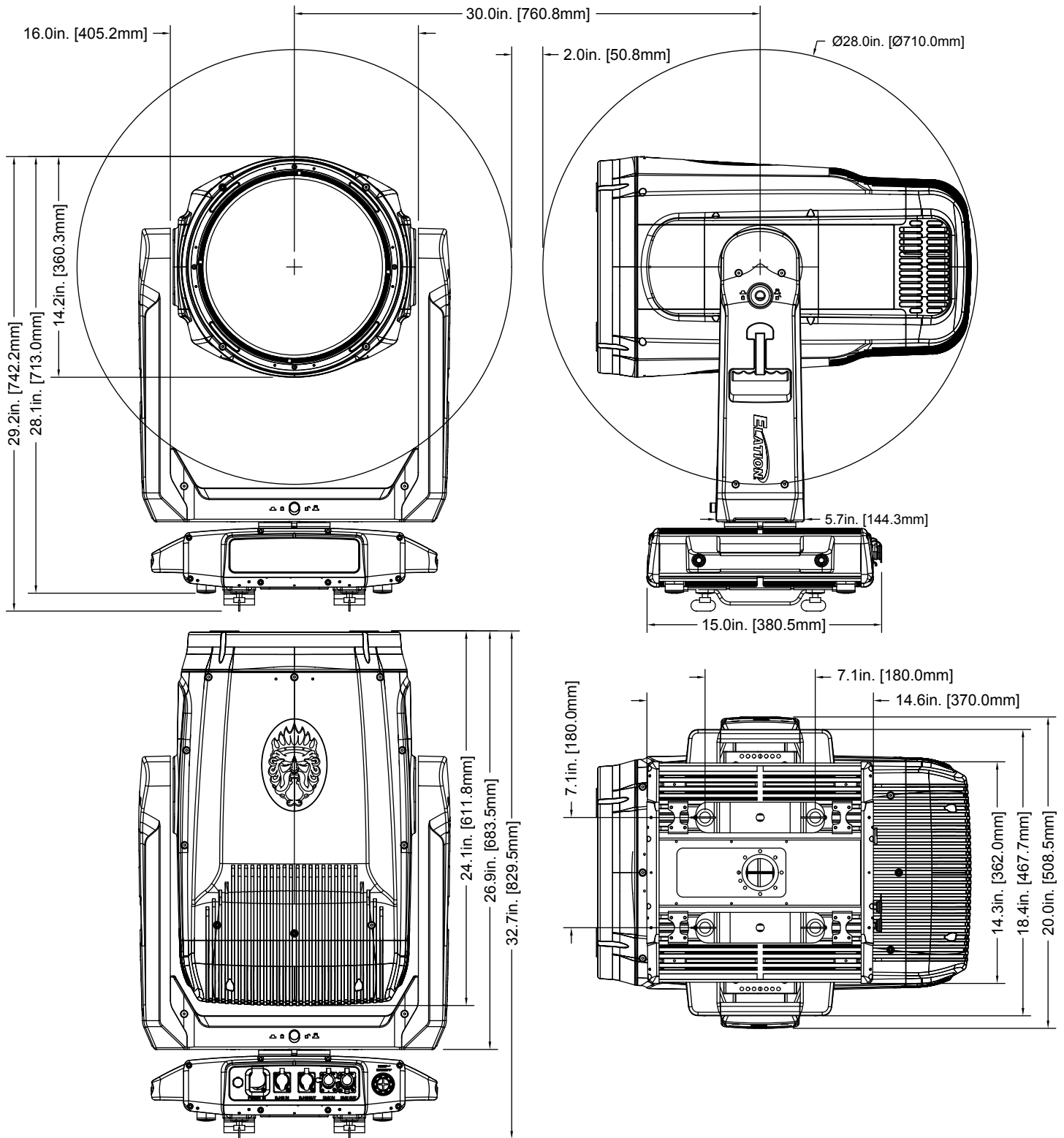

Specifications and documentation subject to change without notice.

DIMENSIONAL DRAWINGS

DRAWINGS NOT TO SCALE

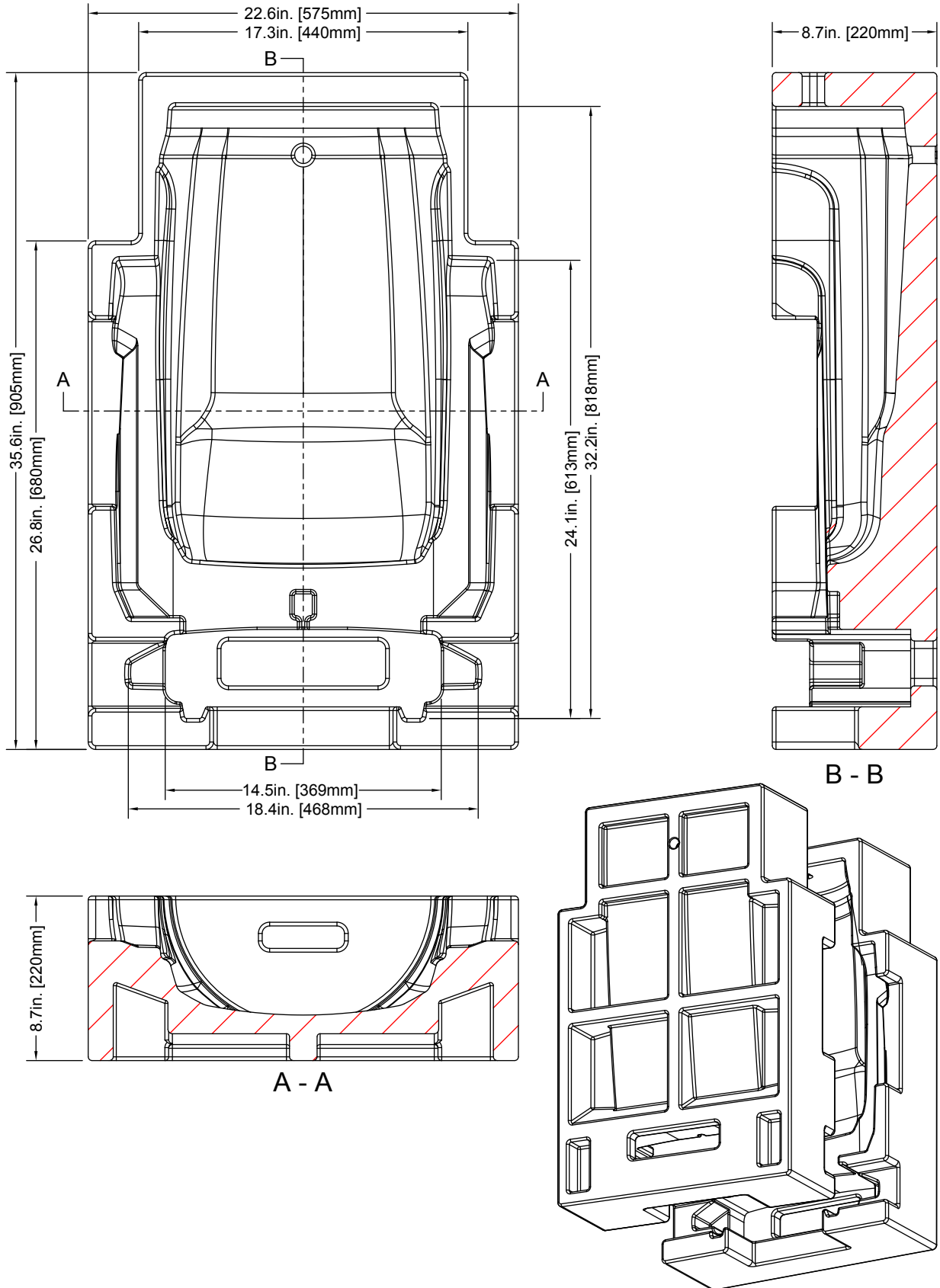

Specifications and documentation subject to change without notice.

OPTIONAL ACCESSORIES

ORDER CODE		ITEM
US	EU	
PRA501	1237000272	Elation Proteus Atlas
TRIGGER CLAMP	N/A	Heavy Duty Wrap Around Hook Style Clamp
SIP126	N/A	5 ft. (1.5m) IP66 Twist Lock Power Link Cable
TOU027	N/A	Tour Link 5pin, 10Ft., Tour Grade, DMX Data Cable
		Additional Cable Lengths Available

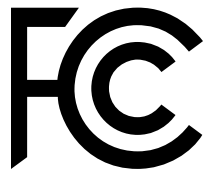

FCC STATEMENT

This device complies with Part 15 of the FCC Rules. Operation is subject to the following two conditions: (1) this device may not cause harmful interference, and (2) this device must accept any interference received, including interference that may cause undesired operation.

FCC RADIO FREQUENCY INTERFERENCE WARNINGS & INSTRUCTIONS

This product has been tested and found to comply with the limits as per Part 15 of the FCC Rules. These limits are designed to provide reasonable protection against harmful interference in a residential installation. This device uses and can radiate radio frequency energy and, if not installed and used in accordance with the included instructions, may cause harmful interference to radio communications. However, there is no guarantee that interference will not occur in a particular installation. If this device does cause harmful interference to radio or television reception, which can be determined by turning the device off and on, the user is encouraged to try to correct the interference by one or more of the following methods:

- Reorient or relocate the device.
- Increase the separation between the device and the receiver.
- Connect the device to an electrical outlet on a circuit different from which the radio receiver is connected.
- Consult the dealer or an experienced radio/TV technician for help.

Energy Saving Matters (EuP 2009/125/EC)

Saving electric energy is a key to help protecting the environment. Please turn off all electrical products when they are not in use. To avoid power consumption in idle mode, disconnect all electrical equipment from power when not in use. Thank you!

