

MAGMATIC

MAGMA FOG 1500IP-II

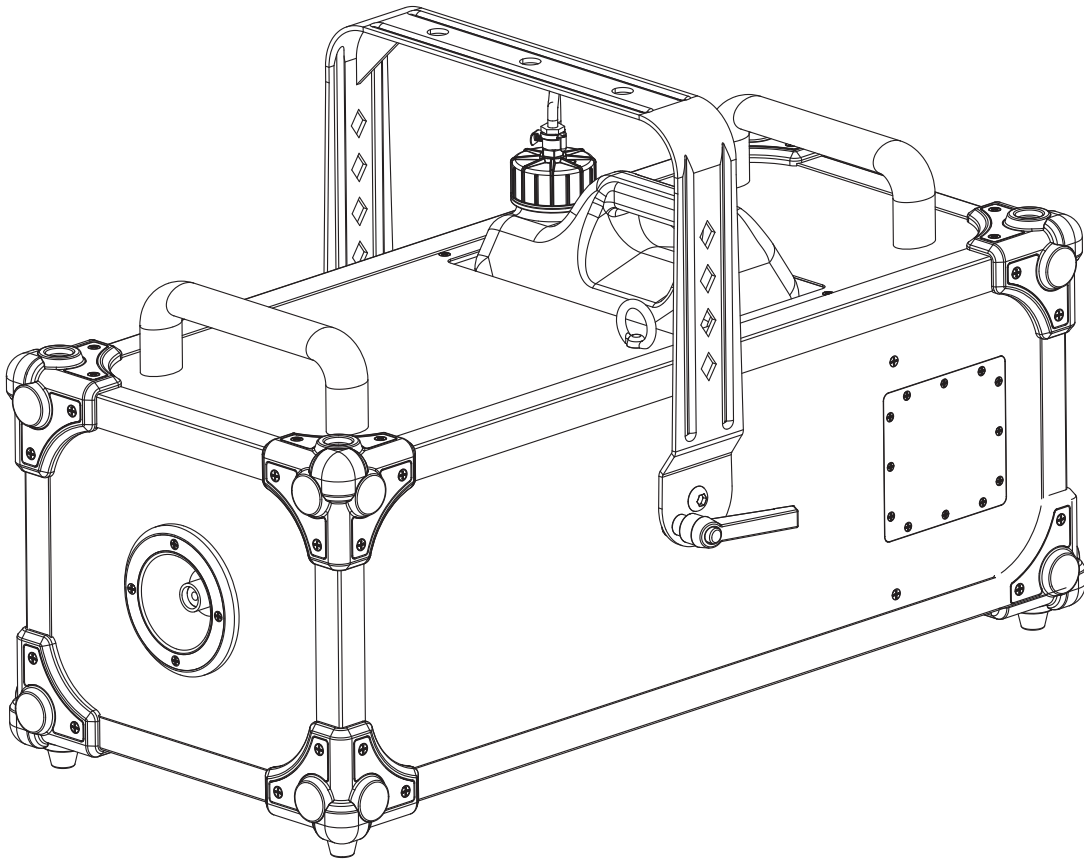

User Manual

©2025 **MAGMATIC EFFECTS** all rights reserved. Information, specifications, diagrams, images, and instructions herein are subject to change without notice. **MAGMATIC EFFECTS** logo and identifying product names and numbers herein are trademarks of **MAGMATIC EFFECTS**. Copyright protection claimed includes all forms and matters of copyrightable materials and information now allowed by statutory or judicial law or hereinafter granted. Product names used in this document may be trademarks or registered trademarks of their respective companies and are hereby acknowledged. All non-MAGMATIC brands and product names are trademarks or registered trademarks of their respective companies.

MAGMATIC EFFECTS and all affiliated companies hereby disclaim any and all liabilities for property, equipment, building, and electrical damages, injuries to any persons, and direct or indirect economic loss associated with the use or reliance of any information contained within this document, and/or as a result of the improper, unsafe, insufficient and negligent assembly, installation, rigging, and operation of this product.

MAGMATIC EFFECTS | 6122 S. Eastern Ave. | Los Angeles, CA. 90040
323-582-3322 | 323-832-9142 fax | www.elationlighting.com | sales@magmaticeffects.com

Elation Professional B.V. | Junostraat 2 | 6468 EW Kerkrade, The Netherlands
+31 45 546 85 66 | +31 45 546 85 96 fax | www.elationlighting.eu | info@elationlighting.eu

Elation Professional Mexico | AC Santa Ana 30 | Parque Industrial Lerma, Lerma, Mexico 52000
+52 (728) 282-7070

DOCUMENT VERSION



Due to additional product features and/or enhancements, an updated version of this document may be available online.

Please check www.elationlighting.com for the latest revision/update of this manual before beginning installation and/or programming.

Date	Document Version	Software Version	DMX Channel Mode	Notes
11/27/23	1	1.5	1 / 2 / 4 channels	Initial Release
05/01/24	1.1	N/C	No Change	Updated Dimensional Drawings, Specifications
09/12/24	1.2	N/C	No Change	Updated Specifications
03/13/25	1.3	N/C	No Change	Updated specifications

CONTENTS

General Information	4
Limited Warranty (USA Only)	5
Warranty Returns (USA Only)	6
IP67 Rated	7
Safety Guidelines	8
Overview	10
Installation Instructions	11
Accessory Installation Instructions	13
Remote Device Management (RDM)	14
Remote Control	15
Setup	16
Control Panel	17
System Menu	18
Message Icons	21
DMX Traits	22
Screw Torque Settings	23
Trouble Shooting Cleaning & Maintenance	25
Dimensional Drawings	26
Specifications	27

GENERAL INFORMATION

INTRODUCTION

Please read and understand the instructions in this manual carefully and thoroughly before attempting to operate this device. These instructions contain important safety and use information. **This product is intended to be used by professionally trained personnel only and is not suitable for private use.**

UNPACKING

Every device has been thoroughly tested and has been shipped in perfect operating condition. Carefully check the shipping carton for damage that may have occurred during shipping. If the carton is damaged, carefully inspect the device for damage, and be sure all accessories necessary to install and operate the device have arrived intact. In the event that damage has been found or parts are missing, please contact our customer support team for further instructions. Please do not return this device to your dealer without first contacting customer support. Please do not discard the shipping carton in the trash. Please recycle whenever possible.

BOX CONTENTS

Twist-Lock Power Cable (x1)

CUSTOMER SUPPORT

Contact **MAGMATIC** customer service for any product related service and support needs. Also visit forums.elationlighting.com with questions, comments, or suggestions.

ELATION SERVICE USA - Monday - Friday 8:00am to 4:30pm PST
323-582-3322 | Fax 323-832-9142 | sales@magmaticeffects.com

ELATION SERVICE EUROPE - Monday - Friday 08:30 to 17:00 CET
Voice: +31 45 546 85 63 | Fax: +31 45 546 85 96 | support@elationlighting.eu

REPLACEMENT PARTS: Please visit parts.elationlighting.com



IMPORTANT NOTICE!

THERE ARE NO USER SERVICEABLE PARTS INSIDE THIS UNIT. DO NOT ATTEMPT ANY REPAIRS YOURSELF, AS DOING SO WILL VOID YOUR MANUFACTURER'S WARRANTY. DAMAGES RESULTING FROM MODIFICATIONS TO THIS FIXTURE AND/OR THE DISREGARD OF SAFETY INSTRUCTIONS AND GUIDELINES IN THIS MANUAL VOID THE MANUFACTURER'S WARRANTY AND ARE NOT SUBJECT TO ANY WARRANTY CLAIMS AND/OR REPAIRS.

NEVER POINT OR AIM A FOG MACHINE TOWARDS PEOPLE OR THEIR CLOTHING. THIS UNIT EMITS HOT VAPOR AND SHOULD BE USED WITH THE SAME CARE THAT YOU WOULD OBSERVE WHEN USING AN ELECTRIC KETTLE OR IRON.

LIMITED WARRANTY (USA ONLY)

- A. Magmatic Effects hereby warrants, to the original purchaser, Magmatic products to be free of manufacturing defects in material and workmanship for a period of two years (730 days) from the original date of purchase. This warranty excludes discharge lamps and all product accessories. This warranty shall be valid only if the product is purchased within the United States of America, including possessions and territories. It is the owner's responsibility to establish the date and place of purchase by acceptable evidence, at the time service is sought.
- B. For warranty service, send the product only to the Magmatic Effects factory. All shipping charges must be pre-paid. If the requested repairs or service (including parts replacement) are within the terms of this warranty, Magmatic Effects will pay return shipping charges only to a designated point within the United States. If any product is sent, it must be shipped in its original package and packaging material. No accessories should be shipped with the product. If any accessories are shipped with the product, Magmatic Effects shall have no liability what so ever for loss and/or or damage to any such accessories, nor for the safe return thereof.
- C. This warranty is void if the product serial number and/or labels are altered or removed; if the product is modified in any manner which Magmatic Effects concludes, after inspection, affects the reliability of the product; if the product has been repaired or serviced by anyone other than the Magmatic Effects factory unless prior written authorization was issued to purchaser by Magmatic Effects; if the product is damaged because not properly maintained as set forth in the product instructions, guidelines and/or user manual.
- D. This is not a service contract, and this warranty does not include any maintenance, cleaning or periodic check-up. During the periods as specified above, Magmatic Effects will replace defective parts at its expense, and will absorb all expenses for warranty service and repair labor by reason of defects in material or workmanship. The sole responsibility of Magmatic Effects under this warranty shall be limited to the repair of the product, or replacement thereof, including parts, at the sole discretion of Magmatic Effects. All products covered by this warranty were manufactured after January 1, 1990, and bear identifying marks to that effect.
- E. Magmatic Effects reserves the right to make changes in design and/or performance improvements upon its products without any obligation to include these changes in any products theretofore manufactured.
- F. No warranty, whether expressed or implied, is given or made with respect to any accessory supplied with the products described above. Except to the extent prohibited by applicable law, all implied warranties made by Magmatic Effects in connection with this product, including warranties of merchantability or fitness, are limited in duration to the warranty periods set forth above. And no warranties, whether expressed or implied, including warranties of merchantability or fitness, shall apply to this product after said periods have expired. The consumer's and/or dealer's sole remedy shall be such repair or replacement as is expressly provided above; and under no circumstances shall Magmatic Effects be liable for any loss and/or damage, direct and/or consequential, arising out of the use of, and/or the inability to use, this product.
- G. This warranty is the only written warranty applicable to Magmatic Effects products and supersedes all prior warranties and written descriptions of warranty terms and conditions heretofore published.

WARRANTY RETURNS (USA ONLY)

To obtain warranty service, a Return Material Authorization (RMA) number must first be obtained from MAGMATIC. It is the Customer's responsibility to provide product proof of purchase and serial number by acceptable evidence such as an invoice copy or an approved MAGMATIC Extended Warranty Certificate ("EWC") and any relevant maintenance records at the time warranty service is sought. Failure to provide acceptable evidence of product proof of purchase or EWC and any relevant maintenance records may be cause for denial of warranty service.

Products returned for warranty service must be sent without any accessories (i.e., power, data, and safety cables, brackets, clamps, rigging hardware, frost filters, gel frames, barn doors, lenses, hoses, nozzles, rack mounting hardware, etc.), must be boxed using the original and/or suitable packaging materials (double-box and foam) that provide ample product protection for ground and/or air freight transit, and must be shipped freight pre-paid and insured to MAGMATIC in Los Angeles, CA or a MAGMATIC Authorized Service Center. The RMA number must be clearly written on the outside of the return box, and a brief description of the problem and the RMA number must be documented and included in the box.

Products returned for warranty service without an RMA number clearly marked on the outside of the package will be refused and returned to the shipper at the Customer's expense. Products returned for warranty service, which are received damaged due to inadequate and/or improper packaging and/or due to damage caused by the shipping carrier, may incur additional repair charges before warranty service begins and/or may void this warranty. If any product accessories (included and/or optional) are shipped with the product, MAGMATIC and/or the MAGMATIC Authorized Service Center shall have no liability what so ever for the loss and/or damage to any such accessories, nor the safe return thereof. If the requested warranty repairs or service (including parts replacement) are within the terms of this warranty, MAGMATIC will pay return ground transportation shipping charges to a single designated point within the United States.

IP67 RATED

The **International Protection (IP)** rating system is commonly expressed as “**IP**” (Ingress Protection) followed by two numbers (i.e. IP67), where the numbers define the degree of protection. The first digit (Foreign Bodies Protection) indicates the extent of protection against particles entering the fixture, and the second digit (Water Protection) indicates the extent of protection against water entering the fixture. An **IP67** rated lighting fixture is designed and tested to protect against the ingress of dust (**6**), and full immersion to a depth of 3.2 ft (1m) (**7**).

NOTE: THIS FIXTURE IS INTENDED FOR TEMPORARY OUTDOOR USE ONLY!

Maritime/Coastal Environment Installations: A coastal environment is seaside adjacent, and caustic to electronics through exposure to atomized salt-water and humidity, whereas maritime is anywhere within 5-miles of a coastal environment. A waterproof dome or similar device is recommended for use in permanent outdoor installations.



NOT suitable for maritime/coastal environment installations. Installing this fixture in a maritime/coastal environment may cause corrosion and/or excessive wear to the interior and/or exterior components of the fixture. Damages and/or performance issues resulting from installation in a maritime/coastal environment will void the manufacturer’s warranty, and will NOT be subject to any warranty claims and/or repairs.

Maritime installations require additional preparation, and additional service intervals may be needed given the maritime use. In general, IP ratings presuppose freshwater conditions VS maritime conditions, which are typically more “caustic” to IP fixtures (both internally and externally). A duty-cycle may also be needed when units are not in use. During times of high humidity and colder temperatures, condensation may occur internally so the fixture may require a duty-cycle to bring it up to running temperature, allowing any accumulation of moisture to be expelled via the vent valve. Recommendations can change based on installation environmental circumstances. A waterproof dome or similar device is recommended for use in permanent outdoor installations. When using a dome, refer to manufacturer recommendations for duty-cycle.

Exterior Maintenance: Inspect the exterior every 30-days. The chassis should be inspected for any signs of contaminants. Inspect optics to determine if the lens is obstructed, then clean optics and chassis accordingly. Based on initial finding, schedule maintenance accordingly, keeping in mind that exterior maintenance will be required. Even if the luminaires are NOT in use, maintenance will still be needed given its location (exterior use). The use of a durable type of wax on the chassis is recommended since it will help prevent contaminant build up. Inspect both power and data lines for any signs of contaminants or corrosion. Periodically reapplying di-electric grease, especially in coastal environments. If any signs of corrosion/contaminants are present, clean thoroughly, and/or replace connectors, then reapply di-electric grease. Typically, this should be done annually, or any time an opportunity presents itself. As a preventive measure, annual replacement of both vent valves is recommended. The vent valve membrane can become contaminated and/or clogged causing improper venting of humidity within the luminaire. Inspect all mounting hardware as a precaution.

Interior Maintenance: An internal inspection of the head is recommended within the first 1,000-1,500 hours of use. The unit must be powered off/disconnected.

- Inspect zoom/focus mechanism, clean optics, lubricate linear bearings (Krytox oil) as needed, inspect belts for wear
- Inspect all rotating effect wheels, manually rotate them, note any resistance
- Inspect all remaining rotating belts for any wear
- Inspect all fans, clean as needed, check rotation, check connections
- Inspect CMY module, manually move flags and check for signs of resistance, and if needed, clean guide rods first, then reapply a thin layer of grease (moly lube)
- Clean interior with low-volume compressed air, then clean optics prior to reassembly of head covers

Although the base has limited moving parts, the pan belt should also be inspected for wear. Remember to always perform an IP test anytime a cover is removed.

There is no specific time frame regarding the routine replacement of parts such as belts/stepper motors, PCBs, or LEDs. These items should only be replaced on an as needed bases, except for cooling fans, which should be replaced once the luminaries reach 10,000-hours. This is a prophylactic measure intended to keep the unit running as cool as possible, insuring proper function of all internal components. A complete service breakdown is available, please contact service@elationlighting.com for any needed parts or manuals.

SAFETY GUIDELINES

This fixture is a sophisticated piece of electronic equipment. To guarantee smooth operation, it is important to follow all instructions and guidelines in this manual. Magmatic Effects is not responsible for injury and/or damages resulting from the misuse of this fixture due to the disregard of the information printed in this manual. Only qualified and/or certified personnel should perform installation of this fixture and only the original parts included with this fixture should be used for installation. Any modifications to the fixture and/or the included mounting hardware will void the original manufacturer's warranty and increase the risk of damage and/or personal injury.



PROTECTION CLASS 1 - FIXTURE MUST BE PROPERLY GROUNDED.



THERE ARE NO USER SERVICEABLE PARTS INSIDE THIS UNIT. DO NOT ATTEMPT ANY REPAIRS YOURSELF. DOING SO WILL VOID YOUR MANUFACTURER'S WARRANTY. DAMAGES RESULTING FROM MODIFICATIONS TO THIS DEVICE AND/OR THE DISREGARD OF SAFETY INSTRUCTIONS AND GUIDELINES IN THIS MANUAL VOID THE MANUFACTURER'S WARRANTY AND ARE NOT SUBJECT TO ANY WARRANTY CLAIMS AND/OR REPAIRS.



**DO NOT PLUG THIS UNIT INTO A DIMMER PACK
KEEP UNIT IN AN UPRIGHT POSITION
NEVER OPERATE THIS UNIT WITH THE COVER REMOVED
UNPLUG FROM POWER DURING LONG PERIODS OF NON-USE
ENSURE TANK IS EMPTY BEFORE STORAGE OR TRANSPORT
DO NOT MOVE WHEN FILLED WITH FLUID
DISCONNECT POWER BEFORE ADDING FLUID OR PERFORMING MAINTENANCE
DO NOT TILT THE MACHINE MORE THAN 30 DEGREES WHILE IN USE**

SAFETY GUIDELINES

- **CAUTION: Fog machines may trigger smoke alarms!**
- Do not attempt to install or operate this device without knowing how to do so.
- Do not direct fog output toward an unsafe direction.
- Do not touch the front nozzle during operation or right after shutdown, as it stays hot then.
- Do not shake the device or use excessive force when installing or operating.
- Keep the packing carton in case the device must be returned for service.
- Confirm the local power source voltage matches the device's required voltage.
- Do not disassemble the device; it has no user-serviceable parts inside.
- Never attach this device to a dimmer pack.
- Do not use this device if it has been damaged in any way.
- Never operate this device with its cover removed.
- Do not use the device if its power cord is frayed, crimped, or damaged. Replace any faulty cords with new ones of matching power rating.
- Do not remove the ground prong from the power cord; it prevents electrical shock and fire.
- Always disconnect the device from power before connecting, cleaning, maintaining, or handling fluid.
- Always empty the fluid before transporting the device.
- Always place this device in an area with adequate ventilation.
- Always unplug power cords during extended periods of non-use.
- Always secure this unit in a safe and stable manner.
- Keep the power cord clear of foot traffic and avoid pinching by objects against them.
- Have the device serviced by qualified personnel when: the power cord or plug is damaged, objects have fallen onto the unit and damaged its casing, or it fails to function normally or shows a clear drop in performance.

OVERVIEW

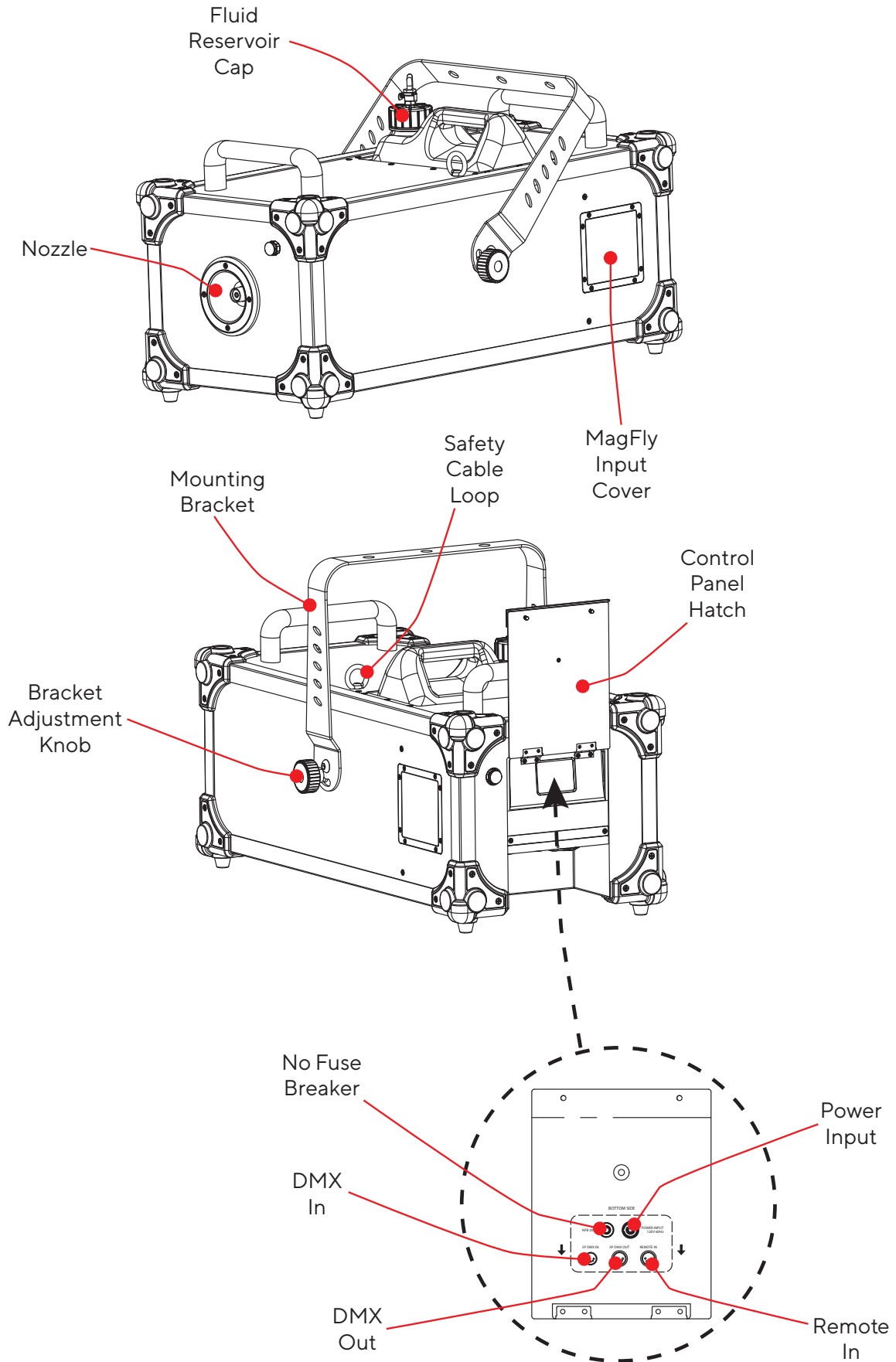

INSTALLATION INSTRUCTIONS



FLAMMABLE MATERIAL WARNING

Keep fixture a minimum of 5 feet (1.5 meters) away from flammable materials and/or pyrotechnics.



ELECTRICAL CONNECTIONS

A qualified electrician should handle all electrical connections and installations.



DO NOT INSTALL THE FIXTURE IF YOU ARE NOT QUALIFIED TO DO SO!

Device **MUST** be installed in accordance with all local, national, and country commercial electrical and construction codes and regulations.

Before rigging/mounting a single device or multiple interconnected devices for custom matrix designs to any metal truss/structure or placing the device(s) on any surface, consult a professional equipment installer to ensure the metal truss/structure or surface is certified to safely hold the combined weight of the device(s), clamps, cables, and accessories.

Maximum ambient operating temperature is **104°F (40°C)**. Do not operate the device if the ambient temperature exceeds this limit.

Install the device(s) outside walking paths, seating areas, and areas where unauthorized personnel might reach the device by hand.

NEVER stand directly below the device(s) when rigging, removing, or servicing.

Allow approximately 15 minutes for the device to cool down before servicing.

Overhead installation must always be secured with a secondary safety attachment, such as an appropriately rated safety cable (not included) that meets all local, national, and country codes and regulations.

INSTALLATION INSTRUCTIONS

CLAMP INSTALLATION

This unit features a mounting yoke with integrated clamp attachment points, as well as a safety cable loop located near the fluid tank (see the illustration below). When mounting this fixture to truss, be sure to secure appropriately rated clamps (not included) to the mounting yoke, and attach a separate **SAFETY CABLE** of the appropriate rating to the safety cable loop. Please note that at least two mounting clamps are required to securely install this device in a suspended environment.

**MOUNTING CLAMP
ATTACHMENT POINT**

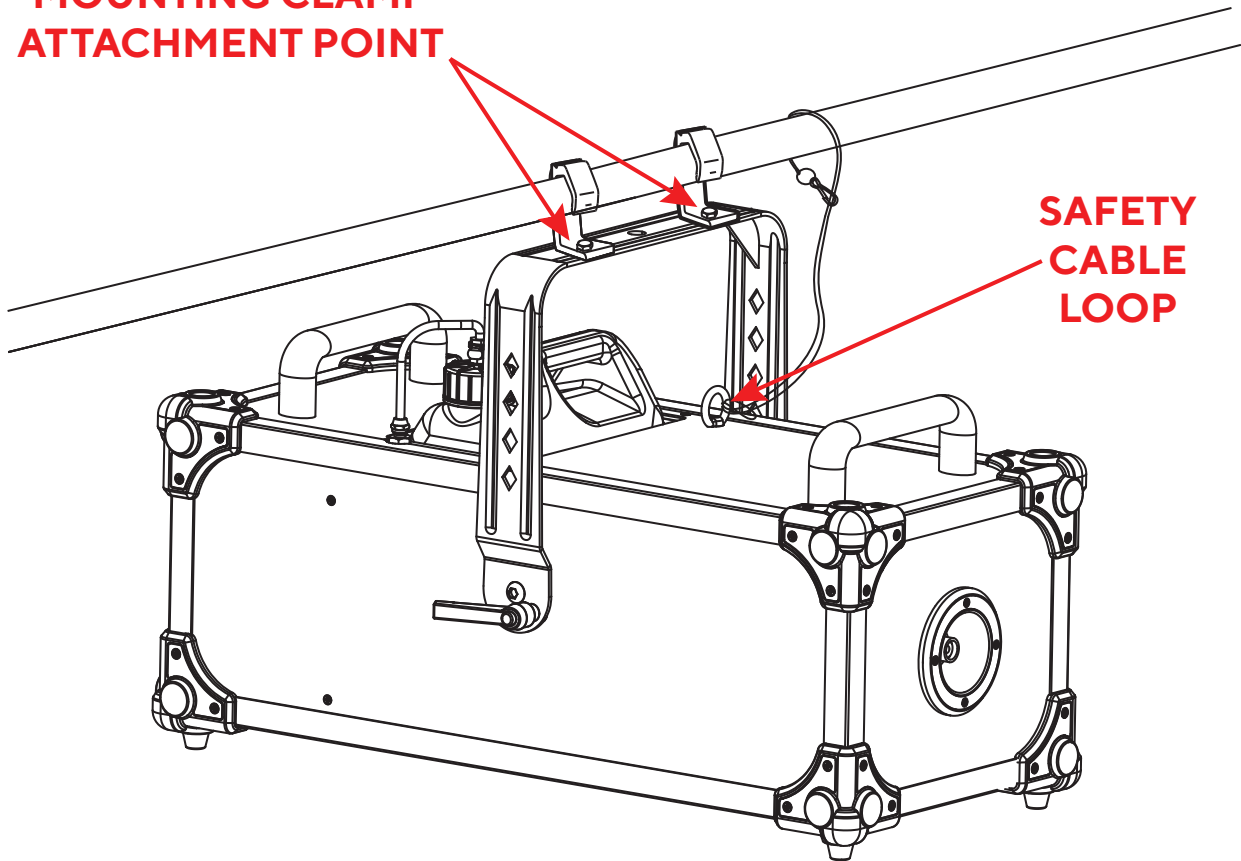

**SAFETY
CABLE
LOOP**



ALWAYS ATTACH A SAFETY CABLE WHEN INSTALLING THIS UNIT IN A SUSPENDED ENVIRONMENT TO ENSURE THAT THE UNIT WILL NOT FALL IN THE EVENT THAT THE CLAMP FAILS.

RIGGING

Overhead rigging requires extensive experience, including but not limited to: calculating working load limits, understanding the installation material being used, and periodic safety inspection of all installation material and the device. If you lack these qualifications, do not attempt the installation yourself. Improper installation can result in bodily injury.

ACCESSORY INSTALLATION INSTRUCTIONS

OPTIONAL MAGFLY WIRELESS CARD

This device features 2 card slots for optional MagFly wireless receiver cards. These card slots are located behind the the MagFly input cover. For ordering information, see the **Accessories** section of this manual.

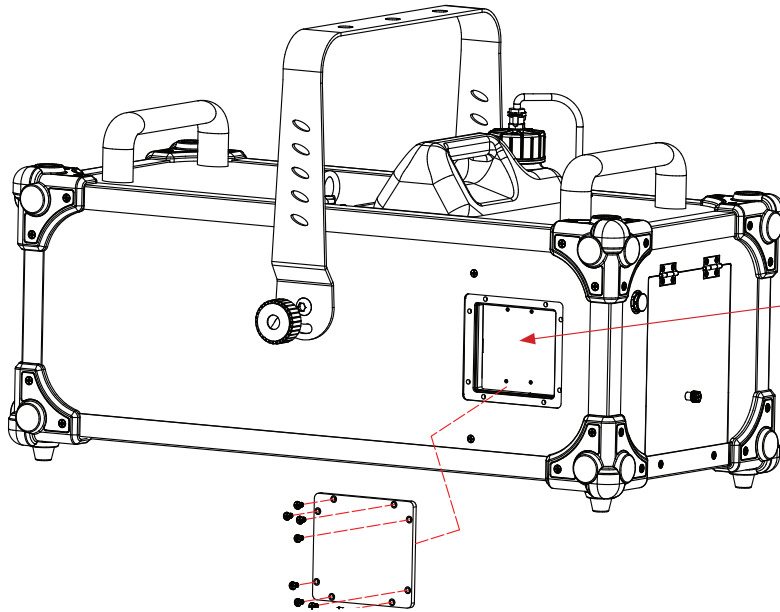

1. Locate the MagFly input cover, and remove all (8) screws with a phillips screw driver.

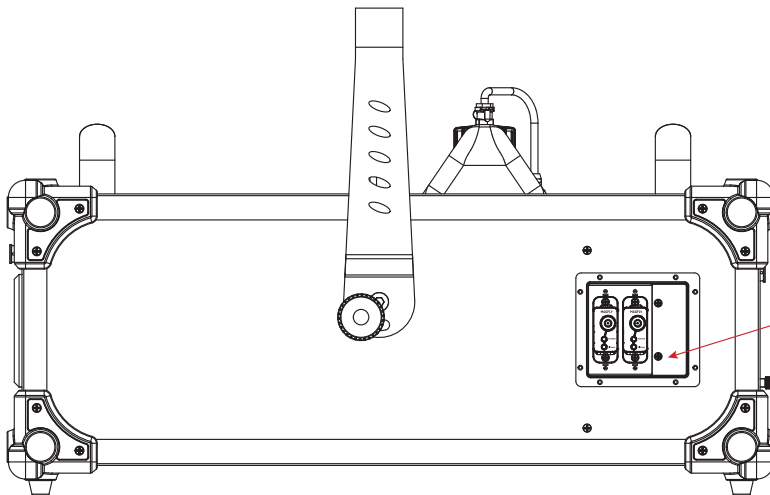

2. Insert up to (2) MagFly receiving cards into the card slots, and press firmly into place. Once the cards are in place, replace the input cover and re-install the screws to fasten the cover in place (see torque settings chapter for correct torque setting specs)

REMOTE DEVICE MANAGEMENT (RDM)

NOTE: In order for RDM to work properly, RDM enabled equipment must be used throughout the entire system, including DMX data splitters and wireless systems.

Remote Device Management (RDM) is a protocol that sits on top of the DMX512 data standard for lighting, allowing the DMX systems of the fixtures to be modified and monitored remotely. This protocol is ideal for instances in which a unit is installed in a location that is not easily accessible.

With RDM, the DMX512 system becomes bi-directional, allowing a compatible RDM enabled controller to send out a signal to devices on the wire, as well as allowing the fixture to respond (known as a GET command). The controller can then use its SET command to modify settings that would typically have to be changed or viewed directly via the unit's display screen, including the DMX Address, DMX Channel Mode, and Temperature Sensors.

FIXTURE RDM INFORMATION:

RDM Code	Device Model ID	Personality ID
22A6H	1110	1-ch (1) 2-ch (2) 4-ch (3)

Please be aware that not all RDM devices support all RDM features, and therefore it is important to check beforehand to ensure that the equipment that you are considering includes all of the features that you require.

The following parameters are accessible in RDM on this device:

[0x1000] Identify Device
[0x00F0] DMX Start Address
[0x00C0] Software Version Label
[0x0060] Device Info
[0x0080] Device Model Description
[0x0081] Manufacturer Label
[0x0082] Device Label
[0x0050] Supported Parameters
[0x00E1] DMX Personality Description
[0x00E0] DMX Personality
[0x0200] Sensor Definition
[0x0201] Sensor Value

REMOTE CONTROL

This unit can be operated using the **MagRemote VIDI** remote control, which is a 4-pin, wired remote that can be used to control the volume, intensity, duration, and interval. Please note that the MagRemote VIDI is a universal remote, and some remote functions may not be applicable to all units.

To operate the device using this remote, simply connect the remote's 4-pin male connector to the matching 4-pin female port on the back of the unit, which is labeled "Remote In." The unit will automatically recognize whether or not the remote has been connection. Available functions are listed below:

Manual Button - Unit outputs when button is pressed, and stops when the button is released. The LED illuminates when unit is outputting, and settings are set on the device's display screen.

Continuous Button - Unit outputs when button is pressed the first time, and continues to output until the button is pressed again or when fog machine needs to reheat. LED flashes when unit is outputting.

Timer On/Off Button - Activates or deactivates the timer function. LED flashes when the function is activated.

Volume Knob - Adjust the volume of the fog output from 5% to 100%.

Intensity Knob - Not applicable to this device.

Duration Knob - Adjust the length of time that the unit will produce fog after reaching the current interval time.

Interval Knob - Adjust the length of time before the unit begins to output fog.

Note - If switching between Vidi Remote and on-screen menu, the unit will respond to the most recent method of input and override the previous method.



SETUP

1. Open the shipping carton and carefully remove the unit. Be sure to remove ALL the packing material, paying particular attention to the area around the fog outlet vent.
2. Set the unit on a flat dry surface, then unscrew the tank cap and fill the reservoir with Atmosity Extreme Filtered Fog Fluid (AEF-2L, AEF-4L, AEF-20L). **Never run the unit on anything other than approved, MAGMATIC branded fluid, as doing so can result in severe damage to your device.**
3. Screw the tank cap back onto the fluid tank. Be careful not to pinch, twist, or tangle the feed tube that is connected to the tank cap.
4. Connect the included power cable to the back of the unit (located underneath the touch-screen display) and connect the the unit to a properly rated power source. Allow the unit to warm up for at least fourteen (14) minutes before beginning fog emission.

CONTROL PANEL

This device includes a system menu with an easy to navigate touch screen control panel where all necessary settings and adjustments can be made. When first powering on the device, the main menu will be displayed.

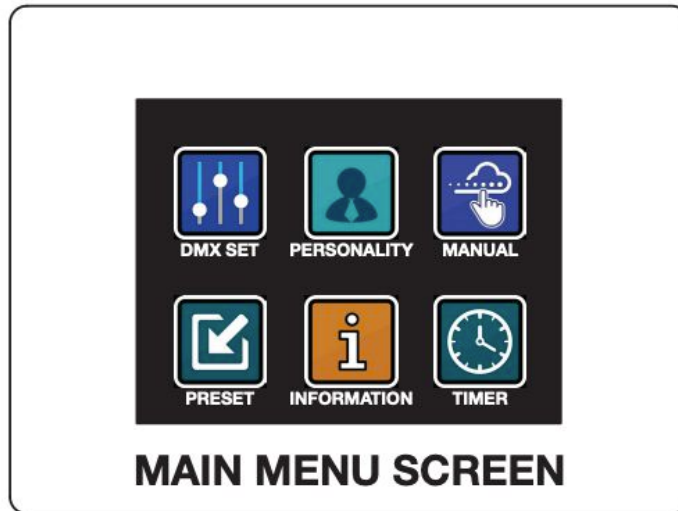

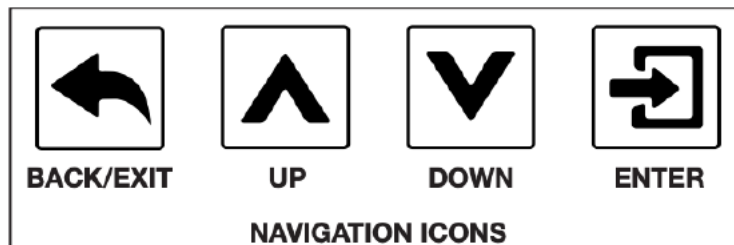

To proceed, press the main menu icon that you would like to access. Use the **ENTER** button to access sub menus and use the **UP** and **DOWN** buttons to make adjustments. Press the **ENTER** button to confirm your adjustments. You may exit the main menu at any time without making any adjustments by pressing the **BACK/EXIT** button.







When using the Timer function, a different set of Timer Icons will be displayed. Press the **SETTINGS** button to adjust the timer function settings. Press the **PLAY/STOP** button at any time to begin operating the device according to the timer settings that have been inputted. You may exit to the main menu at any time by pressing the **BACK/EXIT** button.



SYSTEM MENU

	DMX SET	DMX Addr	1 ~ 512		DMX addressing
		DMX Mode	1-ch		DMX channel mode selection
			2-ch		
4-ch					
	PERSONALITY	MagApp Set	MagApp Name	0~xxxxx	Displays MagApp name
			MagApp Passcode	00000000 - 00009999	MagApp password
			MagApp IP	0 - 255.0	Display IP address
			MagApp Port	0 ~ 65535	Network port
			MagApp Reset	Complete	Network connection reset
				Failed, try again	
		MagApp ->DMX & Magfly	On / Off	Magfly transmit on	
		LCD Set	Screen OFF	Never / 10s / 40s / 1min / 2min / 5min / 10min / 20min	Display blackout time
		MagFly Set	MagFly Channel	0~14	Magfly channel setting
			MagFly	On / Off	Magfly activation
		No Fluid	On / Off		Activate/ deactivate no fluid warning
		MagRF Learn	Connected		Frequency matching capability. Connection failed message displays if connection is unsuccessful after 20s
			Connection Failed, check module and retry		
		Last State	Yes / No		Device adheres to last settings used prior to shutting off
Default	Press "ENTER"		Restores device to factory settings		





SYSTEM MENU

	MANUAL	Fog	1% - 100% (output continuous below 20%)	Manual control
	TIMER	Fog	1% - 100% (output continuous below 20%)	Fog output
		Duration	0s - 250s	Duration setting
		Interval	0s - 2500s	Interval setting
	PRESET	Preset 1: 10s duration, fog 100%, 4s interval		Preset setting 1 (not adjustable)
		Preset 2: 30s duration, fog 80%, 10s interval		Preset setting 2 (not adjustable)
		Preset 3: 60s duration, fog 60%, 30s interval		Preset setting 3 (not adjustable)
		Preset 4: 150s duration, fog 40%, 120s interval		Preset setting 4 (not adjustable)
		Preset 5: 200s duration, fog 30%, 200s interval		Preset setting 5 (not adjustable)
	INFORMATION	State	Normal / Error	Machine status
		Slot 1	Null	Slot 1 status
			MagFly	
			MagApp	
			MagRF	
		Slot 2	Null	Slot 2 status
			MagFly	
			MagApp	
			MagRF	
		Last Control	LCD_auto	Current control status
			LCD_manual	
			DMX	
			MagApp	
MagRF				
MagRemote				
MagRemote State	Yes / No	Remote control status		
MagApp Connect	Null	Wifi connection status		
	Phone			
	Route			
	No			

SYSTEM MENU

	INFORMATION	MagApp IP	No / 0~255, 0~255, 0~255, 0~255	Current Wifi IP status
		MagFly Ch	00 - 14	Current MagFly channel setting
		DMX Addr	1 - 512	Current DMX address
		DMX Mode	1 / 2 / 4	Current DMX channel mode
		Timer Output	0% - 100%	Current timer output
		Timer Int	0s - 2500s	Current timer interval
		Timer Dur	0s - 250s	Current timer duration
		Heating	0% - 100%	Heater progress
		No Fluid	Normal / Empty	Current fluid status
		Heater State	Normal / Error / No Heat	Current heater status
		LCD Ver	Vx.x	Display software version
		Sftwr Ver	Vx.x	Software version

MESSAGE ICONS

Icon	Description
	Icon appears when MagFly module is connected. 4-bar symbol on the right indicates signal strength, with 0 bars being weakest and 4 bars being strongest.
	Icon appears when MagApp module is connected. 4-bar symbol on the right indicates signal strength, with 0 bars being weakest and 4 bars being strongest.
	Icon appears when MagRF module is connected. Note that the icon will only appear if an RF signal exists.
	Icon appears when MagRemote is connected.
	Icon indicates that the fluid tank is empty, and disappears when fluid is added to the tank.

DMX TRAITS

CHANNEL			DMX VALUES	FUNCTION
1-CH	2-CH	4-CH		
				Fog
	1	1	000 - 005	Off
			006 - 255	On
1	2	2	000 - 255	Volume , 1% to 100% (output is continuous at 20% or less)
				Duration
		3	000 - 005	0s
			006 - 255	1s - 250s
				Interval
		4	000 - 005	0s
			006 - 255	10s - 2500s

SCREW TORQUE SETTINGS

TORQUE DRIVERS (Recommended): UTICA TS-30 (Shown)

TORQUE DRIVER (Alternate):

- Proto J6107A
- Wiha 28887



CAUTION! THE USE OF PROTECTIVE GLOVES AND SAFETY GOGGLES IS STRONGLY RECOMMENDED WHILE PERFORMING THE IP PRESSURE TEST! AVOID PLACING YOUR FACE, EYES, HANDS, ETC IN CLOSE PROXIMITY TO THE FIXTURE WHILE PERFORMING THIS TEST!



IP PRESSURE TESTING PARAMETERS		
Low Pressure Limit	High Pressure Limit	Steady/Hold Time
3.04PSI 21kPa	4.49PSI 31kPa	30 seconds

SCREW TORQUE SETTINGS

ALL SCREWS MUST BE TIGHTENED WITH A TORQUE DRIVER. Please refer to the drawing below for screw locations, quantity, and torque settings.



CAUTION! DO NOT OVER TORQUE SCREWS AS THIS CAN CAUSE LEAKAGE ISSUES! TO CONFIRM THE IP67 INTEGRITY AFTER DISASSEMBLY, TEST THE FIXTURE USING THE IP TESTER. CONTACT SERVICE SERVICE FOR MORE DETAILS.

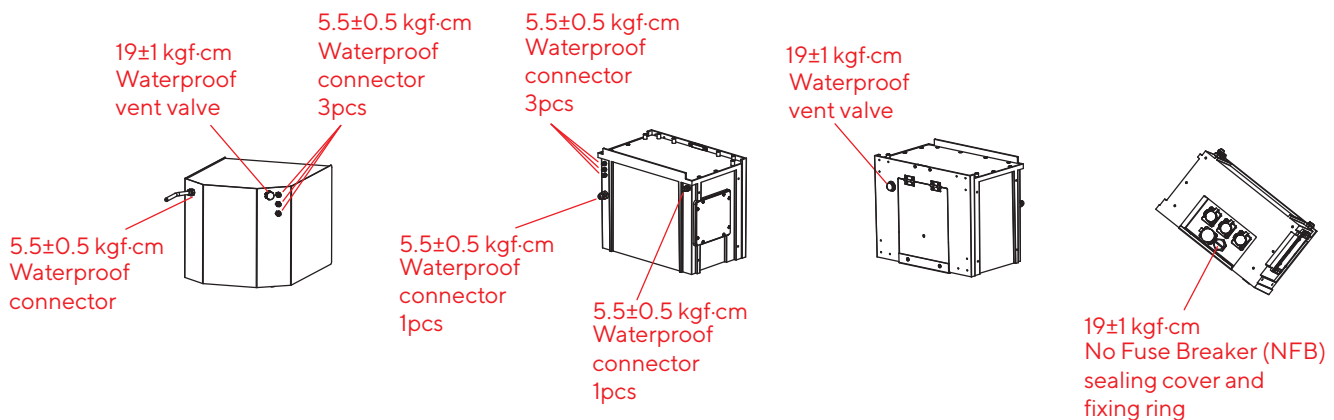
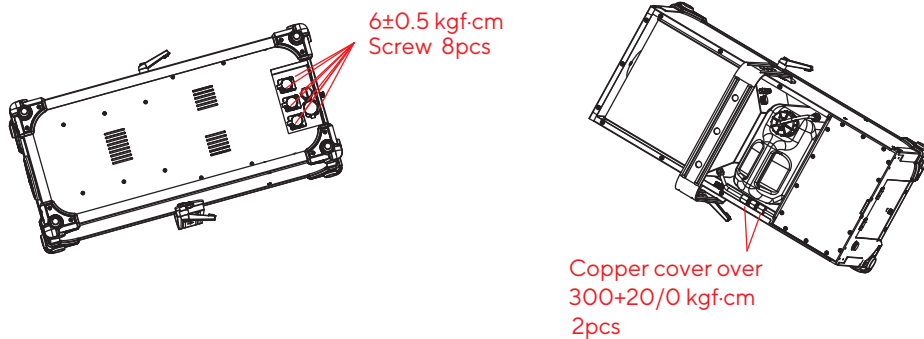
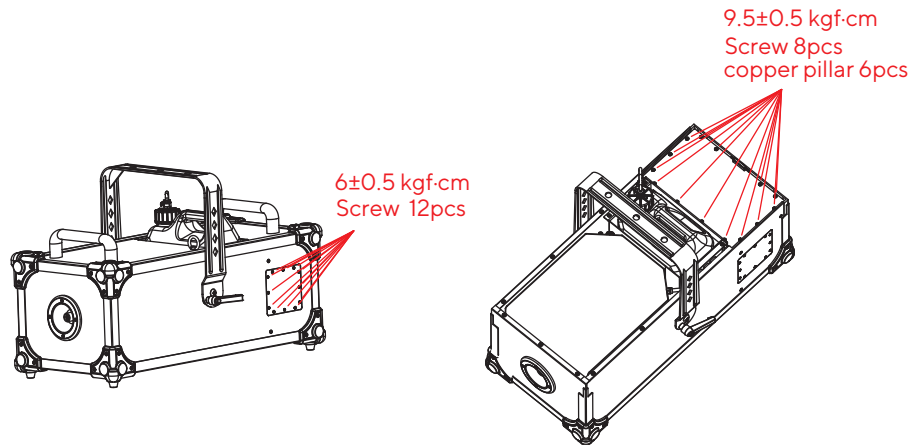

TROUBLE SHOOTING

If you experience low output, pump noise, or no output at all, disconnect the device and discontinue use immediately. Do not attempt to continue operation, as this may damage the machine. Check the fluid level, the breaker, and the wall outlet to make sure that it is sending power. If all the above factors do not appear to be causing the issue, and the unit still fails to operate correctly, the unit will require service. Please contact Magmatic Effects for assistance.

CLEANING & MAINTENANCE

Store this device in a cool area, and cover the device in order to prevent dust build up. When storing for long periods of time, it is highly advisable to run the device at least once every 3-4 months, as long periods of inactivity can severely shorten the life of your device. **Only run Magmatic's Atmosity Extreme Filtered fog fluid through your machine.** Never run plain water, vinegar, or any other liquid solution through your device, as doing so will severely damage your device.

DIMENSIONAL DRAWINGS

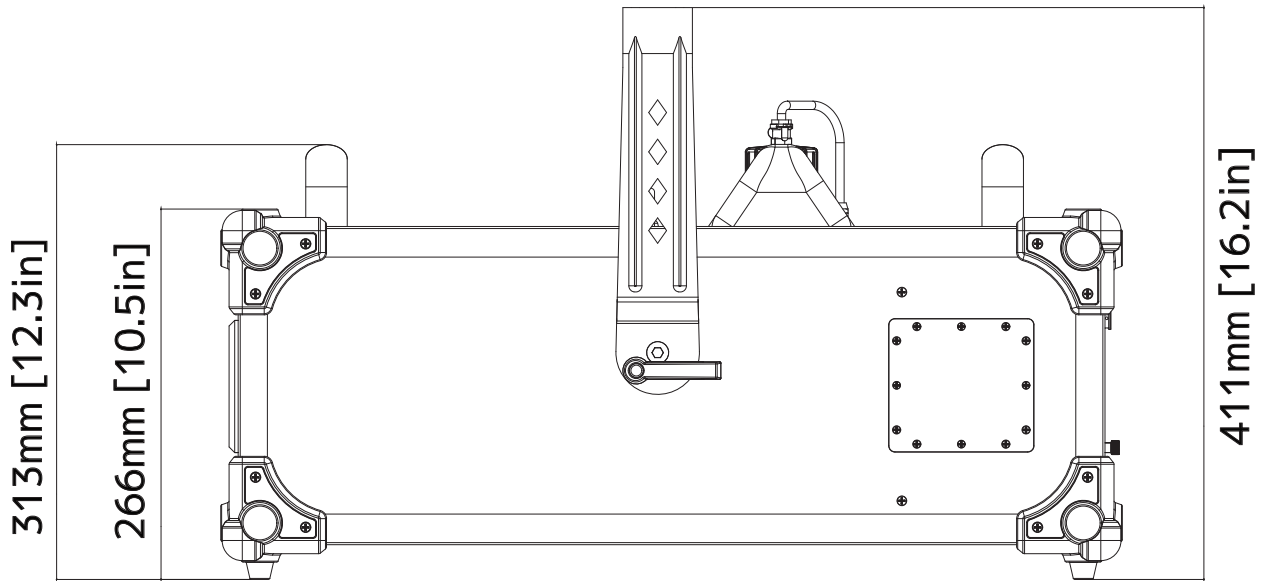
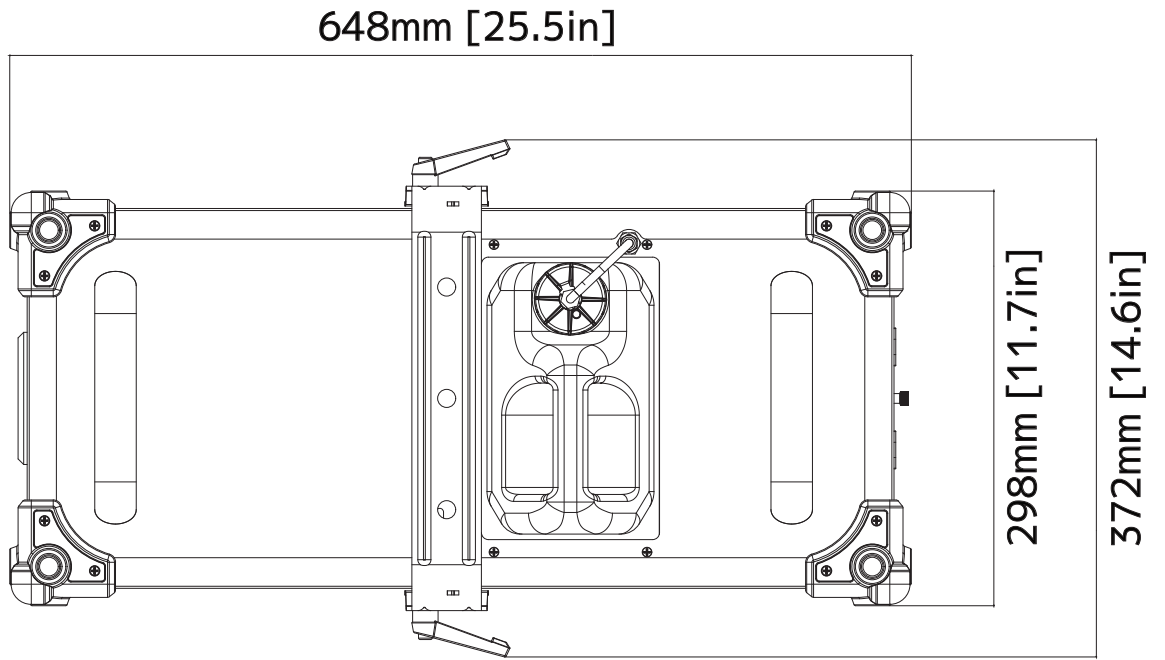

SPECIFICATIONS

PERFORMANCE

Rated Power: 1700W
Max Output: 60,000 CFM* (cu ft/min.)
Ready Time: Initial = 14 Minutes*
Fluid Capacity: 1.32 gallons (5 liters)
Fluid Consumption: 6.76 oz/min (200 ml/min)
*approximate

COMPATIBLE FLUID

Atmosity Extreme Filtered Fog Fluid (AEF-2L, AEF-4L, AEF-20L)

CONSTRUCTION

Thermally Protected Heat Exchanger
Rugged Case Design
Convenient Carry Handles

CONTROL

3 DMX Channel Modes (1 / 2 / 4)
Onboard LCD Touch Control Panel
DMX-512 and RDM Protocol Support
Optional MAGFLY Wireless DMX Transceiver
Optional MAGRF Wireless and MAGREMOTE Wired Remotes

CONNECTIONS

Locking 5pin XLR Connector, DMX In/Out
IP67 Locking Power Connector In
With Wired Digital Communication Network

SIZE / WEIGHT

Length: 25.5 in. (648mm)
Width: 14.6 in. (372mm)
Height: 16.2 in. (411mm)
Weight: 74.3 lbs. (33.7kg)

ELECTRICAL

AC120V 60Hz (US Version)
AC230V 50Hz (EU Version)
20A @ 120VAC(NFB)
10A @ 230VAC - 240VAC
Max Power Consumption: 1700W

THERMAL

Maximum Ambient Temperature (Ta max) 104°F (40°C)
Exterior Surface Temperature, Steady State: 149°F (65°C)

ACCESSORIES

MagFLY (MSR934) Wireless DMX Transceiver Module
MagRF (MSR912) RF Module and Wireless Remote

APPROVALS / RATINGS

CE | IP67 | RoHS | UKCA

