



PROTEUS LUCIUS / W M G

user manual

©2023 ELATION PROFESSIONAL all rights reserved. Information, specifications, diagrams, images, and instructions herein are subject to change without notice. ELATION PROFESSIONAL logo and identifying product names and numbers herein are trademarks of ELATION PROFESSIONAL. Copyright protection claimed includes all forms and matters of copyrightable materials and information now allowed by statutory or judicial law or hereinafter granted. Product names used in this document may be trademarks or registered trademarks of their respective companies and are hereby acknowledged. All non-ELATION brands and product names are trademarks or registered trademarks of their respective companies.

ELATION PROFESSIONAL and all affiliated companies hereby disclaim any and all liabilities for property, equipment, building, and electrical damages, injuries to any persons, and direct or indirect economic loss associated with the use or reliance of any information contained within this document, and/or as a result of the improper, unsafe, insufficient and negligent assembly, installation, rigging, and operation of this product.

Elation Professional USA | 6122 S. Eastern Ave. | Los Angeles, CA. 90040
 323-582-3322 | 323-832-9142 fax | www.elationlighting.com | info@elationlighting.com

Elation Professional B.V. | Junostraat 2 | 6468 EW Kerkrade, The Netherlands
 +31 45 546 85 66 | +31 45 546 85 96 fax | www.elationlighting.eu | info@elationlighting.eu

Elation Professional Mexico | AV Santa Ana 30 | Parque Industrial Lerma, Lerma, Mexico 52000
 +52 (728) 282-7070

DOCUMENT VERSION



Due to additional product features and/or enhancements, an updated version of this document may be available online. Please scan the QR Code with your mobile device or visit www.elationlighting.com for the latest revision/update of this manual, before installation and/or programming.

Date	Document Version	SoftwareVersion ≥	DMX Channel Modes	Notes
08/25/2020	1.0	1.3.0	43 / 68	Initial Release
12/22/2020	2.0	1.3.0	43 / 68	Updated Specifications and Dimensional Drawings
03/25/2021	3.0	1.3.0	43 / 68	Updated Maintenance
05/26/2021	4.0	1.3.0	43 / 68	Updated Maintenance
08/13/2021	5.0	1.3.0	43 / 68	Updated Format
11/04/2021	6.0	1.3.0	43 / 68	Added Battery Installation
01/18/2022	7.0	1.3.0	43 / 68	Updated General Information and Specifications
04/01/2022	8.0	N/C	43 / 68	Updated Specifications
07/14/2022	9.0	1.3.0	No Change	Added Sun Protection
11/09/2022	10.0	1.6.1	No Change	Updated System Menu, DMX Traits, & Specifications
03/17/2023	11.0	1.6.2	No Change	Updated System Menu, DMX Traits
05/11/2023	12.0	N/C	No Change	Updated Installation Guidelines, Dimensional Drawings, Specifications
06/22/2023	13.0	N/C	No Change	Removed Tipping Page
07/19/2023	14.0	N/C	No Change	Updated IP65 Rated, Specifications, Optional Accessories
12/11/2023	15.0	N/C	No Change	Updated Installation Guidelines, Specifications.

CONTENTS

General Information	4
Limited Warranty (USA Only)	5
Safety Guidelines	7
Maintenance Guidelines	8
IP65 Rated	9
Overview	10
Colors and Gobos	11
Gobo Installation	15
Torque Settings for Screws	16
Fan Modes and Low Noise Operation	17
Installation Guidelines	18
Sun Protection Mode Hibernation Mode	25
System Menu	26
Dimmer Mode / Dimmer Curve	33
DMX Traits: Channel Functions & Values	34
Remote Device Management (RDM)	44
Error Codes	45
Specifications	46
Dimensional Drawings	47
Optional Accessories	49

GENERAL INFORMATION

FOR PROFESSIONAL USE ONLY

INTRODUCTION

Please read and understand the instructions in this manual carefully and thoroughly before attempting to operate this device. These instructions contain important safety and use information.

COOLING

After usage, the lamp may be switched off, but the fixture should remain connected to power in order to allow the fan time to cool down the fixture.

UNPACKING

Every device has been thoroughly tested and has been shipped in perfect operating condition. Carefully check the shipping carton for damage that may have occurred during shipping. If the carton is damaged, carefully inspect the device for damage, and be sure all accessories necessary to install and operate the device have arrived intact. In the event damage has been found or parts are missing, please contact our customer support team for further instructions. Please do not return this device to your dealer without first contacting customer support. Please do not discard the shipping carton in the trash. Please recycle whenever possible.

BOX CONTENTS

Omega Brackets (x2)

IP65 Rated 5pin DMX Cable

IP65 Rated RJ45 DATA Cable (Fixture to Fixture Interconnect Use Only!)

IP65 Rated Twist-Lock Power Cable

CUSTOMER SUPPORT

Contact ELATION Service for any product related service and support needs.

Also visit forums.elationlighting.com with questions, comments or suggestions.

ELATION SERVICE USA - Monday - Friday 8:00am to 4:30pm PST

323-582-3322 | Fax 323-832-9142 | support@elationlighting.com

ELATION SERVICE EUROPE - Monday - Friday 08:30 to 17:00 CET

+31 45 546 85 63 | Fax +31 45 546 85 96 | support@elationlighting.eu

REPLACEMENT PARTS please visit parts.elationlighting.com

LIMITED WARRANTY (USA ONLY)

- A. Elation Professional hereby warrants, to the original purchaser, Elation Professional products to be free of manufacturing defects in material and workmanship for a period of two years (730 days), and Elation Professional product rechargeable batteries to be free of manufacturing defects in material and workmanship for a period of six months (180 days), from the original date of purchase. This warranty excludes discharge lamps and all product accessories. This warranty shall be valid only if the product is purchased within the United States of America, including possessions and territories. It is the owner's responsibility to establish the date and place of purchase by acceptable evidence, at the time service is sought.
- B. For warranty service, send the product only to the Elation Professional factory. All shipping charges must be pre-paid. If the requested repairs or service (including parts replacement) are within the terms of this warranty, Elation Professional will pay return shipping charges only to a designated point within the United States. If any product is sent, it must be shipped in its original package and packaging material. No accessories should be shipped with the product. If any accessories are shipped with the product, Elation Professional shall have no liability what so ever for loss and/or damage to any such accessories, nor for the safe return thereof.
- C. This warranty is void if the product serial number and/or labels are altered or removed; if the product is modified in any manner which Elation Professional concludes, after inspection, affects the reliability of the product; if the product has been repaired or serviced by anyone other than the Elation Professional factory unless prior written authorization was issued to purchaser by Elation Professional; if the product is damaged because not properly maintained as set forth in the product instructions, guidelines and/or user manual.
- D. This is not a service contract, and this warranty does not include any maintenance, cleaning or periodic check-up. During the periods as specified above, Elation Professional will replace defective parts at its expense, and will absorb all expenses for warranty service and repair labor by reason of defects in material or workmanship. The sole responsibility of Elation Professional under this warranty shall be limited to the repair of the product, or replacement thereof, including parts, at the sole discretion of Elation Professional. All products covered by this warranty were manufactured after January 1, 1990, and bare identifying marks to that effect.
- E. Elation Professional reserves the right to make changes in design and/or performance improvements upon its products without any obligation to include these changes in any products theretofore manufactured.
- F. No warranty, whether expressed or implied, is given or made with respect to any accessory supplied with the products described above. Except to the extent prohibited by applicable law, all implied warranties made by Elation Professional in connection with this product, including warranties of merchantability or fitness, are limited in duration to the warranty periods set forth above. And no warranties, whether expressed or implied, including warranties of merchantability or fitness, shall apply to this product after said periods have expired. The consumer's and/or dealer's sole remedy shall be such repair or replacement as is expressly provided above; and under no circumstances shall Elation Professional be liable for any loss and/or damage, direct and/or consequential, arising out of the use of, and/or the inability to use, this product.
- G. This warranty is the only written warranty applicable to Elation Professional products and supersedes all prior warranties and written descriptions of warranty terms and conditions heretofore published.

WARRANTY RETURNS

All returned service items whether under warranty or not, must be freight pre-paid and accompany a return authorization (R.A.) number. The R.A. number must be clearly written on the outside of the return package. A brief description of the problem as well as the R.A. number must also be written down on a piece of paper and included in the shipping container. If the unit is under warranty, you must provide a copy of your proof of purchase invoice. Items returned without a R.A. number clearly marked on the outside of the package will be refused and returned at customer's expense. You may obtain a R.A. number by contacting customer support.

SAFETY GUIDELINES

This fixture is a sophisticated piece of electronic equipment. To guarantee a smooth operation, it is important to follow all instructions and guidelines in this manual. Elation Professional is not responsible for injury and/or damages resulting from the misuse of this fixture due to the disregard of the information printed in this manual. Only qualified and/or certified personnel should perform installation of this fixture and only the original rigging parts (omega brackets) included with this fixture should be used for installation. Any modifications to the fixture and/or the included mounting hardware will void the original manufacturer's warranty and increase the risk of damage and/or personal injury.



PROTECTION CLASS 1 - FIXTURE MUST BE PROPERLY GROUNDED.



**THERE ARE NO USER SERVICEABLE PARTS INSIDE THIS UNIT.
DO NOT ATTEMPT ANY REPAIRS YOURSELF; DOING SO WILL VOID YOUR MANUFACTURER'S WARRANTY. DAMAGES RESULTING FROM MODIFICATIONS TO THIS FIXTURE AND/OR THE DISREGARD OF SAFETY INSTRUCTIONS AND GUIDELINES IN THIS MANUAL VOID THE MANUFACTURER'S WARRANTY AND ARE NOT SUBJECT TO ANY WARRANTY CLAIMS AND/OR REPAIRS.**



ENSURE ALL CONNECTIONS AND END CAPS ARE PROPERLY SEALED WITH A DIELECTRIC GREASE (AVAILABLE AT MOST ELECTRICAL SUPPLIERS) TO PREVENT WATER CORROSION AND/OR ELECTRICAL SHORT CIRCUIT.



**DO NOT PLUG FIXTURE INTO A DIMMER PACK!
NEVER OPEN THIS FIXTURE WHILE IN USE!
UNPLUG POWER BEFORE SERVICING FIXTURE!
NEVER TOUCH FIXTURE DURING OPERATION, AS IT MAY BE HOT!
KEEP FLAMMABLE MATERIALS AWAY FROM FIXTURE!**



**NEVER LOOK DIRECTLY INTO THE LIGHT SOURCE!
RETINA INJURY RISK - MAY INDUCE BLINDNESS!
SENSITIVE PERSONS MAY SUFFER AN EPILEPTIC SHOCK!**



**MINIMUM DISTANCE TO OBJECTS/SURFACES
MUST BE 65.6 FEET (20 METERS)
MAXIMUM TEMP OF EXTERNAL SURFACE 185° F (85°C)
MINIMUM DISTANCE OF INFLAMMABLE MATERIALS
FROM THE SURFACE 1.6 FEET (0.5 METER)**

SAFETY GUIDELINES



89.9 lbs. (40.8kg)

WARNING

TWO PERSON LIFT REQUIRED

! CAUTION

HIGH INTENSITY ULTRAVIOLET LIGHT



AVOID DIRECT EYE & SKIN EXPOSURE.
WEAR PROPER EYE & SKIN PROTECTION.
SEE MANUAL FOR SAFETY INSTRUCTIONS.

RISK GROUP 3 - RISK OF EXPOSURE TO ULTRAVIOLET UV RADIATION! FIXTURE EMITS HIGH INTENSITY WAVELENGTH OF ULTRAVIOLET UV LIGHT FROM THE UV COLOR FILTER. WEAR PROPER EYE AND SKIN PROTECTION. AVOID PROLONGED PERIODS OF EXPOSURE TO UV COLOR FILTER. AVOID WEARING WHITE COLOR CLOTHING AND/OR USING UV PAINTS ON SKIN. AVOID DIRECT EYE AND/OR SKIN EXPOSURE AT DISTANCES LESS THAN 65.6 feet (20m). DO NOT OPERATE FIXTURE WITH DAMAGED/MISSING EXTERNAL COVERS. DO NOT LOOK DIRECTLY INTO THE UV LIGHT AND/OR VIEW UV LIGHT DIRECTLY WITH OPTICAL INSTRUMENTS THAT MAY CONCENTRATE THE LIGHT/RADIATION OUTPUT.

INDIVIDUALS SUFFERING FROM A RANGE OF EYE CONDITIONS, SUNLIGHT EXPOSURE DISORDERS, OR INDIVIDUALS USING PHOTSENSITIVE MEDICATION, MAY RECEIVE DISCOMFORT IF EXPOSED TO THE ULTRAVIOLET UV LIGHT EMITTED FROM THE UV LED.

DO NOT TOUCH the fixture housing during operation. Turn OFF the power and allow approximately 15 minutes for the fixture to cool down before serving.

DO NOT shake fixture, avoid brute force when installing and/or operating fixture.

DO NOT operate fixture if the power cord is frayed, crimped, damaged and/or if any of the power cord connectors are damaged and do not insert into the fixture securely with ease. NEVER force a power cord connector into the fixture. If the power cord or any of its connectors are damaged, replace it immediately with a new one of similar power rating.

DO NOT block any air ventilation slots.

All fan and air inlets must remain clean and never blocked.

Allow approx. 6" (15cm) between fixture and other devices or a wall for proper cooling.

Always disconnect fixture from main power source before performing any type of service and/or cleaning procedure. Only handle the power cord by the plug end, never pull out the plug by tugging the wire portion of the cord.

During the initial operation of this fixture, a light smoke or smell may emit from the interior of the fixture. This is a normal process and is caused by excess paint in the interior of the casing burning off from the heat associated with the lamp and will decrease gradually over time.

Consistent operational breaks will ensure fixture will function properly for many years.

ONLY use the original packaging and materials to transport the fixture in for service.

MAINTENANCE GUIDELINES



DISCONNECT POWER BEFORE PERFORMING ANY MAINTENANCE!

CLEANING

Frequent cleaning is recommended to insure proper function, optimized light output, and an extended life. The frequency of cleaning depends on the environment in which the fixture operates: damp, smoky or particularly dirty environments can cause greater accumulation of dirt on the fixture's optics. Clean the external lens surface at least every 20 days with a soft cloth to avoid dirt/debris accumulation.

NEVER use alcohol, solvents, or ammonia-based cleaners.

MAINTENANCE

Regular inspections are recommended to insure proper function and extended life.

There are no user serviceable parts inside this fixture, please refer all other service issues to an authorized Elation service technician. Should you need any spare parts, please order genuine parts from an authorized Elation dealer.

Please refer to the following points during routine inspections:

A detailed electric check by an approved electrical engineer every three months, to make sure the circuit contacts are in good condition and prevent overheating.

Be sure all screws and fasteners are securely tightened at all times. Loose screws may fall out during normal operation resulting in damage or injury as larger parts could fall.

Check for any deformations on the housing, color lenses, rigging hardware and rigging points (ceiling, suspension, trussing). Deformations in the housing could allow for dust to enter into the fixture. Damaged rigging points or unsecured rigging could cause the fixture to fall and seriously injure a person(s).

Electric power supply cables must not show any damage, material fatigue or sediments.

NEVER remove the ground prong from the power cable.

FIXTURE DISASSEMBLY

The following points should be observed after performing any maintenance procedure that requires disassembly of the unit:

- After the unit has been reassembled, open the valve, and allow the light to run for approximately 2 hours in order to dry out any moisture that has been trapped inside the fixture. The process should continue until indicated humidity drops below 15% for the head and 30% for the base.
- Once this has been achieved, the light can be switched off, but the unit should remain connected to power so that the cooling fan can cool down the unit. Please note that allowing cool down time should **ALWAYS** be done after lamp operation.
- Some units may require partial disassembly in order to gain access to the valve. Please contact Elation service for information regarding the location and access procedure for the valve on your specific unit model.

IP65 RATED

The International Protection (IP) rating system is commonly expressed as “IP” (Ingress Protection) followed by two numbers (i.e. IP65), where the numbers define the degree of protection. The first digit (Foreign Bodies Protection) indicates the extent of protection against particles entering the fixture, and the second digit (Water Protection) indicates the extent of protection against water entering the fixture. An **IP65** rated lighting fixture is designed and tested to protect against the ingress of dust (**6**), and low-pressure water jets from any direction (**5**).

Maritime/Coastal Environment Installations: A coastal environment is seaside adjacent, and caustic to electronics through exposure to atomized salt-water and humidity, whereas maritime is anywhere within 5-miles of a coastal environment.

Maritime installations require additional preparation, and additional service intervals may be needed given the maritime use. In general, IP ratings presuppose freshwater conditions VS maritime conditions, which are typically more “caustic” to IP fixtures (both internally and externally). A duty-cycle may also be needed when units are not in use. During times of high humidity and colder temperatures, condensation may occur internally so the fixture may require a duty-cycle to bring it up to running temperature, allowing any accumulation of moisture to be expelled via the vent valve. Recommendations can change based on installation environmental circumstances.

NOTE: NOT ALL FEATURES LISTED ARE AVAILABLE ON ALL FIXTURES; THE FOLLOWING INSTRUCTIONS MAY NOT APPLY. CONTACT SUPPORT FOR ADDITIONAL DETAILS.

Exterior Maintenance: Inspect the exterior every 30-days. The unit must be powered off/disconnected. The chassis should be inspected for any signs of contaminants. Inspect optics to determine if the lens is obstructed, then clean optics and chassis accordingly. Based on initial finding, schedule maintenance accordingly, keeping in mind that exterior maintenance will be required. Even if the luminaires are NOT in use, maintenance will still be needed given its location (exterior use). The use of a durable type of wax on the chassis is recommended since it will help prevent contaminant build up. Inspect both power and data lines for any signs of contaminants or corrosion. Periodically reapplying di-electric grease, especially in coastal environments. If any signs of corrosion/contaminants are present, clean thoroughly, and/or replace connectors, then reapply di-electric grease. Typically, this should be done annually, or any time an opportunity presents itself. As a preventive measure, annual replacement of both vent valves is recommended. The vent valve membrane can become contaminated and/or clogged causing improper venting of humidity within the luminaire. Inspect all mounting hardware as a precaution.

Interior Maintenance: Inspect the interior every 30-days. The unit must be powered off/disconnected.

- Inspect zoom/focus mechanism, clean optics, lubricate linear bearings (Krytox oil) as needed, inspect belts for wear
- Inspect all rotating effect wheels, manually rotate them, note any resistance
- Inspect all remaining rotating belts for any wear
- Inspect all fans, clean as needed, check rotation, check connections
- Inspect CMY module, manually move flags and check for signs of resistance, and if needed, clean guide rods first, then reapply a thin layer of grease (moly lube)
- Clean interior with low-volume compressed air, then clean optics prior to reassembly of head covers

Although the base has limited moving parts, the pan belt should also be inspected for wear. Remember to always perform an IP test anytime a cover is removed.

There is no specific time frame regarding the routine replacement of parts such as belts/stepper motors, PCBs, or LEDs. These items should only be replaced on an as needed bases, except for cooling fans, which should be replaced once the luminaries reach 10,000-hours. This is a prophylactic measure intended to keep the unit running as cool as possible, insuring proper function of all internal components. A complete service breakdown is available, please contact service@elationlighting.com for any needed parts or manuals.

OVERVIEW

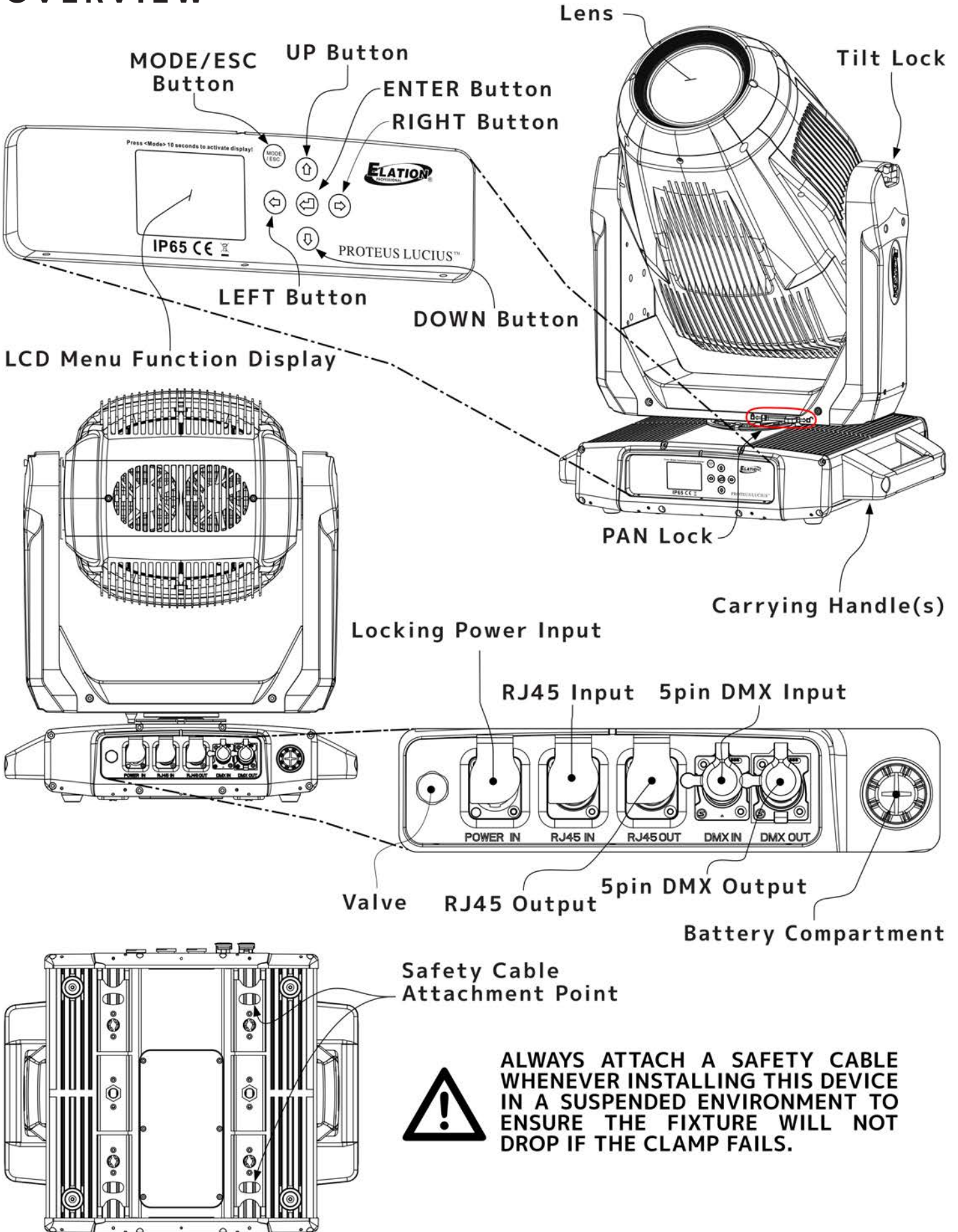

COLORS AND GOBOS

COLOR FLAGS

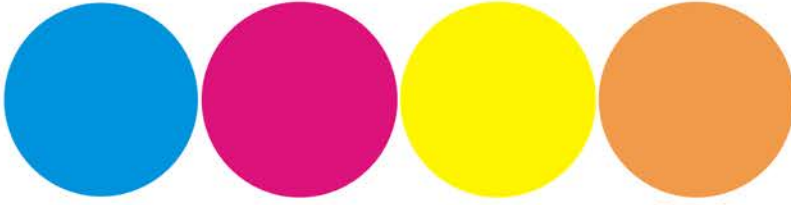

CYAN MAGENTA YELLOW C.T.O.

COLOR WHEEL



RED GREEN HIGH CRI ORANGE BLUE

INTERCHANGEABLE – ROTATING GLASS GOBO WHEEL

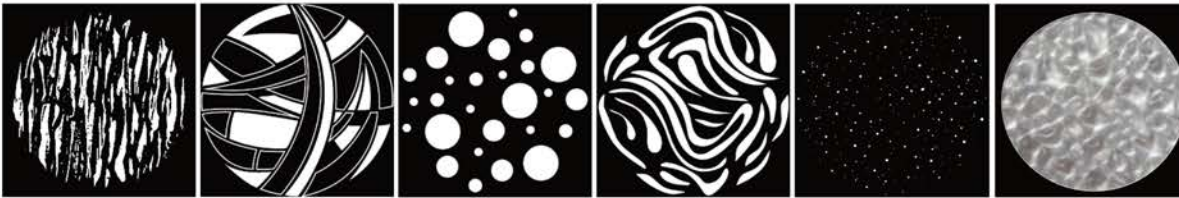

Pos. 1 Pos. 2 Pos. 3 Pos. 4 Pos. 5 Pos. 6

INTERCHANGEABLE – ROTATING GLASS GOBO WHEEL



Pos. 1 Pos. 2 Pos. 3 Pos. 4 Pos. 5 Pos. 6 Pos. 7

INTERCHANGEABLE STATIC – FIXED GLASS GOBO WHEEL



Pos. 1 Pos. 2 Pos. 3 Pos. 4 Pos. 5 Pos. 6 Pos. 7

BI-DIRECTIONAL ANIMATION WHEEL

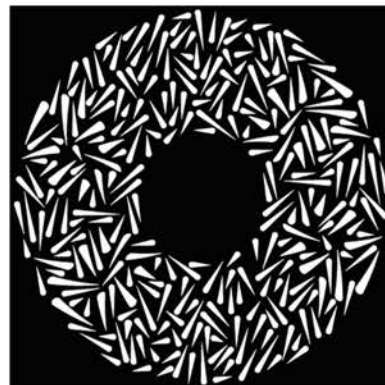

COLORS AND GOBOS

ROTATING WHEEL1 GOBOS - Pos. 1-5:	
Gobo Holder Diameter	Ø34mm
Gobo O.D. (Max. Outer Diameter)	Ø33.8mm
Gobo I.D. (Max. Image Diameter)	Ø21mm
Gobo Thickness	1.1mm±0.1mm
Gobo Material	CORNING

ROTATING WHEEL1 GOBOS - Pos. 6:	
Gobo Holder Diameter	Ø34mm
Gobo O.D. (Max. Outer Diameter)	Ø34mm
Gobo I.D. (Max. Image Diameter)	Ø21mm
Gobo Thickness	2.5mm±0.1mm
Gobo Material	GLASS

ROTATING WHEEL1 GOBOS

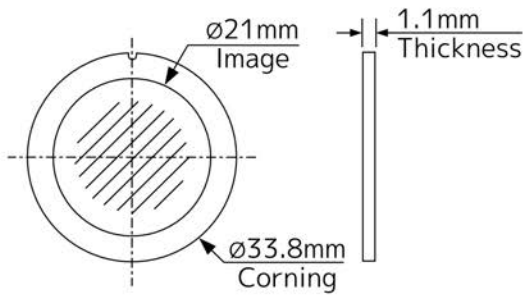

Pos. 1 - Pos. 5

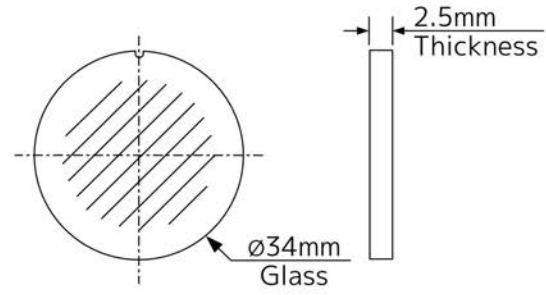

Pos. 6

ROTATING WHEEL1 GOBO HOLDERS

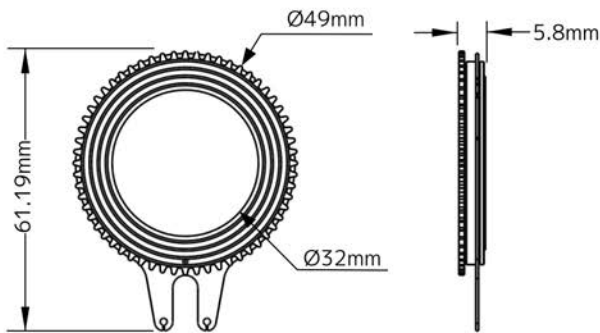

5.01.02.01.0685-0

Pos. 1 - Pos. 5

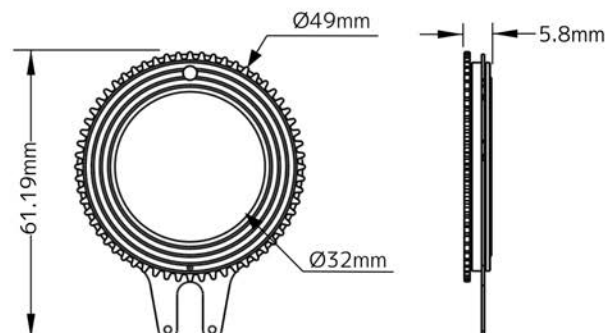

5.01.02.01.0599-0

Pos. 6

Proteus Lucius utilizes different size gobo holders on every wheel.

Please be aware of the intended position and correct sizing requirements of custom gobos.

***** IMPORTANT NOTICE REGARDING CUSTOM GOBOS *****

Due to the high temperature optical system, special glass material is required for custom gobos. Due to varying manufacturing processes and tolerances, it is highly recommended to provide a gobo sample and holder from the fixture to the custom gobo vendor for accurate sizing. Extended testing of custom gobo designs is highly recommended prior to use. Contact ELATION SERVICE for further information.

ELATION SERVICE USA -Monday -Friday 8:00am to 4:30pm PST
323-582-3322 | Fax 323-832-9142 | support@elationlighting.com

ELATION SERVICE EUROPE -Monday -Friday 08:30 to 17:00 CET
+31 45 546 85 63 | Fax +31 45 54685 96 | support@elationlighting.eu

COLORS AND GOBOS

ROTATING WHEEL2 GOBOS - Pos. 1-6:	
Gobo Holder Diameter	Ø27mm
Gobo O.D. (Max. Outer Diameter)	Ø26.8mm
Gobo I.D. (Max. Image Diameter)	Ø21mm
Gobo Thickness	1.1mm±0.1mm
Gobo Material	CORNING

ROTATING WHEEL2 GOBOS - Pos. 7:	
Gobo Holder Diameter	Ø27mm
Gobo O.D. (Max. Outer Diameter)	Ø26.8mm
Gobo I.D. (Max. Image Diameter)	Ø21mm
Gobo Thickness	2.5mm±0.1mm
Gobo Material	CORNING

ROTATING WHEEL2 GOBOS

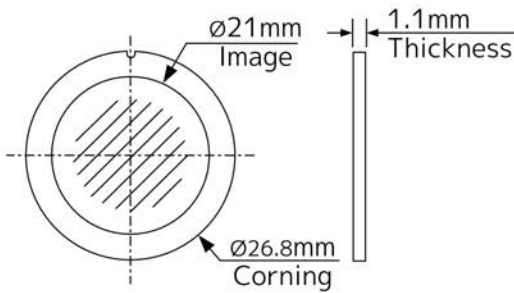

Pos. 1 - Pos. 6

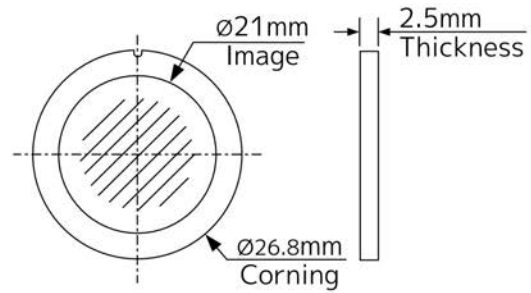

Pos. 7

ROTATING WHEEL2 GOBO HOLDERS

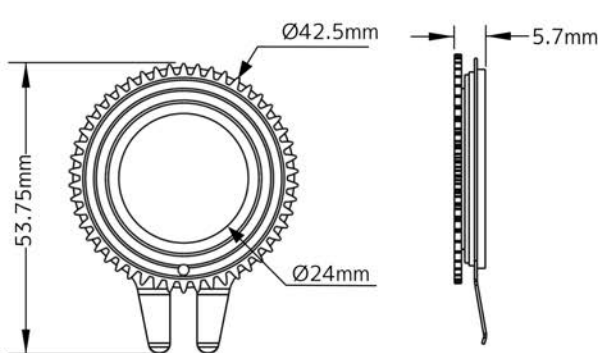

5.01.02.01.0684-0

Pos. 1 - Pos. 6

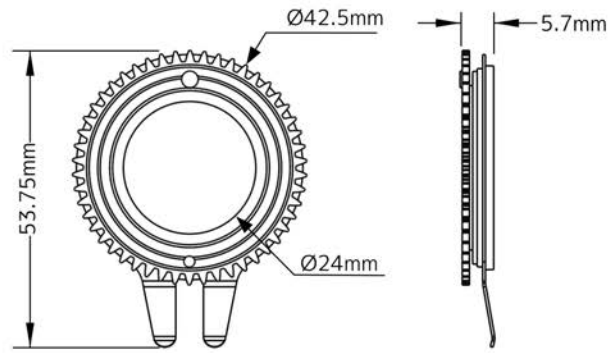

5.01.02.01.0598-0

Pos. 7

Proteus Lucius utilizes different size gobo holders on every wheel.

Please be aware of the intended position and correct sizing requirements of custom gobos.

***** IMPORTANT NOTICE REGARDING CUSTOM GOBOS *****

Due to the high temperature optical system, special glass material is required for custom gobos. Due to varying manufacturing processes and tolerances, it is highly recommended to provide a gobo sample and holder from the fixture to the custom gobo vendor for accurate sizing. Extended testing of custom gobo designs is highly recommended prior to use. Contact ELATION SERVICE for further information.

ELATION SERVICE USA -Monday -Friday 8:00am to 4:30pm PST
323-582-3322 | Fax 323-832-9142 | support@elationlighting.com

ELATION SERVICE EUROPE -Monday -Friday 08:30 to 17:00 CET
+31 45 546 85 63 | Fax +31 45 54685 96 | support@elationlighting.eu

COLORS AND GOBOS

FIXED WHEEL GOBOS:	
Gobo Holder Diameter	Ø30mm
Gobo O.D. (Max. Outer Diameter)	Ø29.8mm
Gobo I.D. (Max. Image Diameter)	Ø21mm
Gobo Thickness	1.1mm±0.1mm
Gobo Material	CORNING

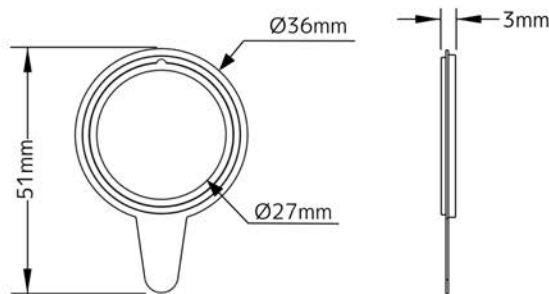
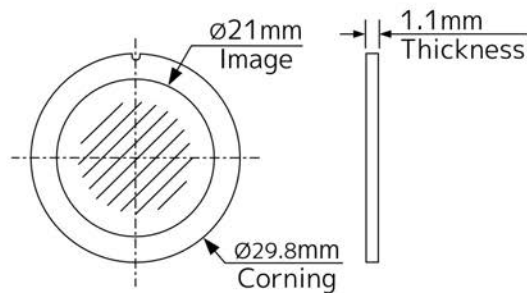

5.01.02.01.0694-0

Proteus Lucius utilizes different size gobo holders on every wheel.

Please be aware of the intended position and correct sizing requirements of custom gobos.

***** IMPORTANT NOTICE REGARDING CUSTOM GOBOS *****

Due to the high temperature optical system, special glass material is required for custom gobos. Due to varying manufacturing processes and tolerances, it is highly recommended to provide a gobo sample and holder from the fixture to the custom gobo vendor for accurate sizing. Extended testing of custom gobo designs is highly recommended prior to use. Contact ELATION SERVICE for further information.

ELATION SERVICE USA -Monday -Friday 8:00am to 4:30pm PST
323-582-3322 | Fax 323-832-9142 | support@elationlighting.com

ELATION SERVICE EUROPE -Monday -Friday 08:30 to 17:00 CET
+31 45 546 85 63 | Fax +31 45 54685 96 | support@elationlighting.eu

GOBO INSTALLATION



REPLACING A ROTATING GOBO

Locate the specific Rotating GOBO to replace. Carefully grip the GOBO using your thumb and index



Locate the tab of the spring, and with a precision pick (or similar tool), carefully press the retaining spring inward to relieve the tension. Remove the retaining spring and carefully separate the GOBO from the GOBO Holder. Lastly, remove the flat washer attached to the removed GOBO and attach it to the desired replacement GOBO. Install the replacement Rotating GOBO following the steps above in reverse order.

CAUTION: TAKE CARE NOT TO SCRATCH GOBO OR GOBO HOLDER

REPLACING A STATIC GOBO



Rotate the Static GOBO Wheel until the desired GOBO is visible through the OPEN slot in the Rotating GOBO Wheel. Using a precision pick (or similar tool), carefully press the Static GOBO Holder down slightly, then using your thumb and index finger, gently pull it out and away until it fully clears the GOBO Wheel.

Locate the tab of the retaining spring. Using a precision pick (or similar tool), carefully press the retaining spring inward to relieve the tension. Remove the retaining spring and carefully separate the GOBO from the GOBO Holder. Lastly, remove the flat washer attached to the removed GOBO and attach it to the desired replacement GOBO. Install the replacement Static GOBO following the steps above in reverse

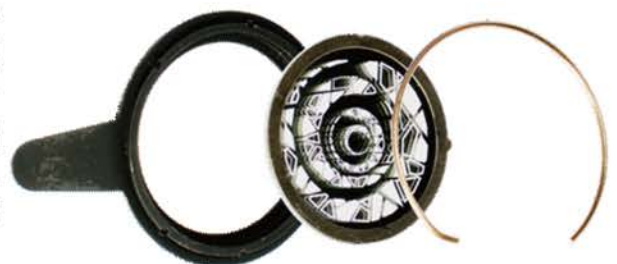

TORQUE SETTINGS FOR SCREWS

The hex-head screws holding either the panels or the base MUST be tightened with a torque wrench (not included).

TORQUE SETTING
11 lbf-in. (12.7kgf-cm)*

* lbf-in = Pound Force Inches
 kgf-cm = Kilogram Force Centimeters



CAUTION! DO NOT OVER TORQUE SCREWS AS THIS CAN CAUSE LEAKAGE ISSUES! TO CONFIRM THE IP65 INTEGRITY AFTER A LAMP REPLACEMENT, TEST FIXTURE USING THE ELATION IP TESTER. CONTACT ELATION SERVICE FOR MORE DETAILS.



CAUTION! THE USE OF PROTECTIVE GLOVES AND SAFETY GOGGLES IS STRONGLY RECOMMENDED WHILE PERFORMING THE IP PRESSURE TEST! AVOID PLACING YOUR FACE, EYES, HANDS, ETC IN CLOSE PROXIMITY TO THE FIXTURE'S LENS WHILE PERFORMING THE TEST!



IP PRESSURE TESTING PARAMETERS			
Test Type	Low Pressure Limit	High Pressure Limit	Hold Time
Vacuum Test	-4.35psi (-30.00 KPa)	-5.08 psi (-35.00 KPa)	10s
Pressure Test	3.62 psi (25.00 KPa)	4.35 psi (30.00 KPa)	10s



FAN CONTROL AND LOW NOISE OPERATION

The Elation Proteus Lucius is a high-performance fixture suited for multiple applications. For noise critical environments such as Theater, Opera, or Orchestral Halls, it offers various fan operation modes which remove unwanted noise distractions for the audience and performers. Fan Modes can be changed remotely via the DMX control channel, allowing the fixture to offer high output or whisper-silent operation at a moment's notice. All Fan Modes smoothly transition over a brief period, preventing unwanted attraction to the fixture.

Mode	dbA at 1m LED off	dbA at 1m Dimmer 100%
Fan Control - Auto (Default)	39	47
Fan Control - High	40	55
Fan Control - Low	37	42
Low Noise – Studio	34	37
Low Noise – Mute/Silent	31	31

Auto (Default) – Fans only run at the speeds needed to keep the LED engine within a safe temperature range, and ensures optimal performance of the fixture. They will turn off if possible; for example, when the fixture is dimmed to a low intensity. Fans sense the ambient and fixture temperature and will, at all times, try to keep noise levels at a minimum. The fixture output will only be reduced when the LED engine cannot be cooled to its safe operating range due to a high ambient temperature.

NOTE: This mode is recommended for daily operation.

Silent – Fan speeds are reduced throughout the fixture for a lower noise profile. The fixture output is also reduced to approximately 80%. This mode should be sufficient for most uses where lower noise is required.

High – Fan speeds are increased throughout the fixture for the most efficient cooling. This mode will increase wear on the fans and should only be utilized in exceptional circumstances. Fans will always run, even if the fixture is dimmed. Fixture output is kept at 100% unless the LED engine temperature reaches an unsafe temperature, at which point the fixture will reduce power carefully to ensure continued safe operation. This mode is only required in very high ambient temperatures when automatic fan speed adjustments are not desired.

Low Noise Modes

For very critical noise environments, the fixture offers two additional Low Noise Modes for silent operation. The fixture output will be reduced, yet due to the extremely high luminous flux, the fixture still offers outstanding performance. In Low Noise Modes, all parameters of the fixture operate more quietly with reduced fan speeds.

Mute – All but one fixture fan is turned off for whisper-quiet operation. The fixture LED power output is reduced to 25%.

INSTALLATION GUIDELINES



FLAMMABLE MATERIAL WARNING

Keep fixture minimum 5.0 feet (1.5m) away from flammable materials and/or pyrotechnics.



ELECTRICAL CONNECTIONS

A qualified electrician should be used for all electrical connections and/or installations.



USE CAUTION WHEN POWER LINKING OTHER MODEL FIXTURES AS THE POWER CONSUMPTION OF OTHER MODEL FIXTURES MAY EXCEED THE MAX POWER OUTPUT ON THIS FIXTURE. CHECK SILK SCREEN FOR MAX AMPS.



MINIMUM DISTANCE TO OBJECTS/SURFACES MUST BE 1.6 FOOT (0.5 METERS)



MINIMUM DISTANCE OF INFLAMMABLE MATERIALS FROM THE SURFACE 1.6 FEET (0.5 METER)



AMBIENT TEMPERATURE RANGE IS -4° F TO 113° F (-20°C TO 45°C)



DO NOT INSTALL THE FIXTURE IF YOU ARE NOT QUALIFIED TO DO SO!

Fixture **MUST** be installed following all local, national, and country commercial electrical and construction codes and regulations.

Before rigging/mounting the fixture to any metal truss/structure or placing the fixture on any surface, a professional equipment installer **MUST** be consulted to determine if the metal truss/structure or surface is properly certified to safely hold the combined weight of the fixture, clamps, cables, and accessories.

Overhead rigging requires extensive experience, including, amongst others, calculating working load limits, installation material being used, and periodic safety inspection of all installation material and the fixture. If you lack these qualifications, do not attempt the installation yourself. Improper installation can result in bodily injury.

Fixture ambient operating temperature range is **-4° to 113°F. (-20° to 45°C).**

Do not use the fixture under or above this temperature.

Fixture should be installed in areas outside walking paths, seating areas, or away from areas where unauthorized personnel might reach the fixture by hand.

NEVER stand directly below the fixture when rigging, removing or servicing.

Overhead fixture installation must always be secured with a secondary safety attachment, such as an appropriately rated safety cable.

Allow approximately 10 minutes for the fixture to cool down before serving.

INSTALLATION GUIDELINES

OMEGA BRACKETS WITH CLAMP INSTALLATION

Insert the Omega Brackets into the matching holes on the bottom of the fixture. Secure the Omega Brackets to the fixture by turning each quick-lock fastener $\frac{1}{4}$ turn clockwise; making sure the fastener is completely locked. Omega Brackets can be installed into the fixture base as illustrated below.

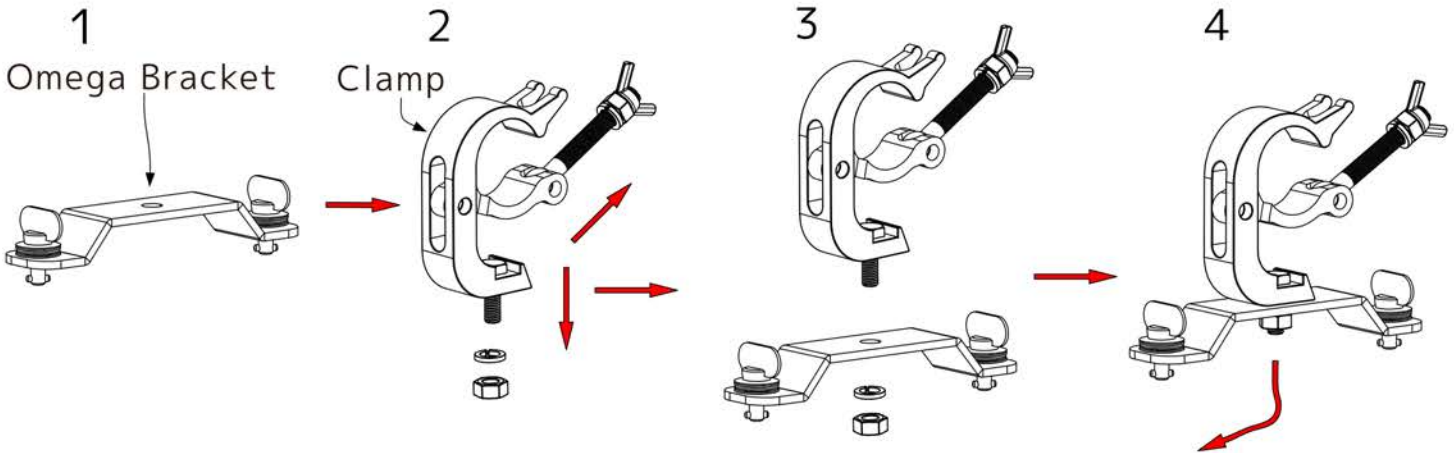

SAFETY CABLE

ALWAYS ATTACH AN APPROPRIATELY RATED SAFETY CABLE WHENEVER INSTALLING THIS FIXTURE IN A SUSPENDED ENVIRONMENT TO ENSURE THE FIXTURE WILL NOT FALL IF THE CLAMP FAILS.

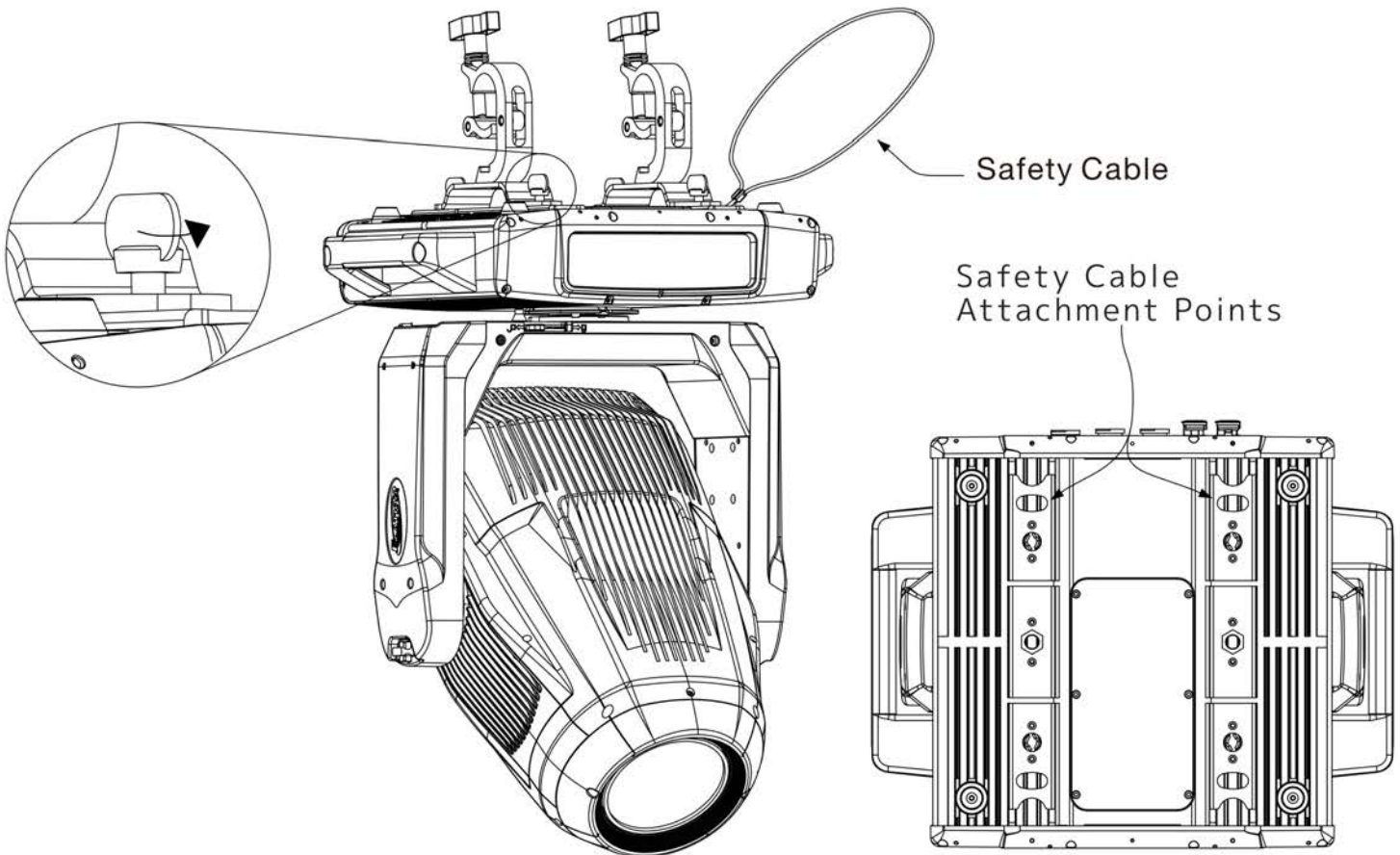

MOUNTING THE FIXTURE ON A TRUSS USING CLAMPS WITH OMEGA BRACKETS

When mounting the fixture to a truss, be sure to secure an appropriately rated professional grade rigging clamp to the included **Omega Brackets** using an M10 screw fitted through the center hole of the **Omega Brackets**. The fixture provides built-in rigging points for a **SAFETY CABLE** (not included). Be sure to only use one of the designated rigging points for the safety cable and never secure a safety cable to a carrying handle.

INSTALLATION GUIDELINES

CLAMP INSTALLATION

Insert (2x) minimum grade 8.8 steel M12x25mm bolts (not included) through the respective mounting hole of the clamp (not included), and then thread it into the matching 12M holes on the bottom of the fixture base. Both bolts must be threaded at least 18mm (0.7ins) into the fixture base.

(2xM12) Threaded Holes,
max. Screw length 19mm

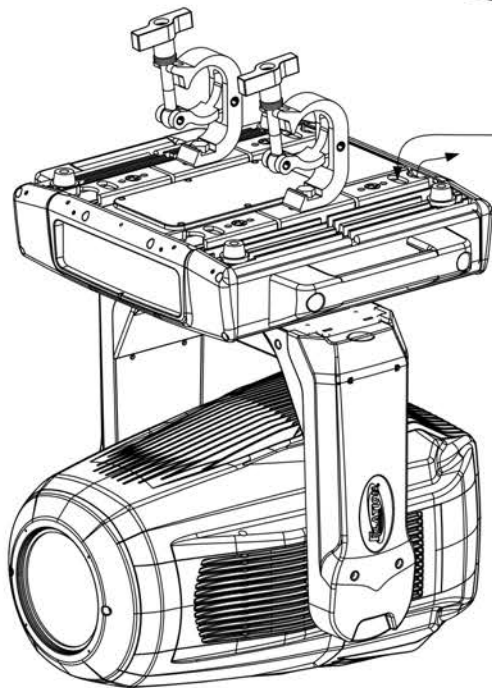
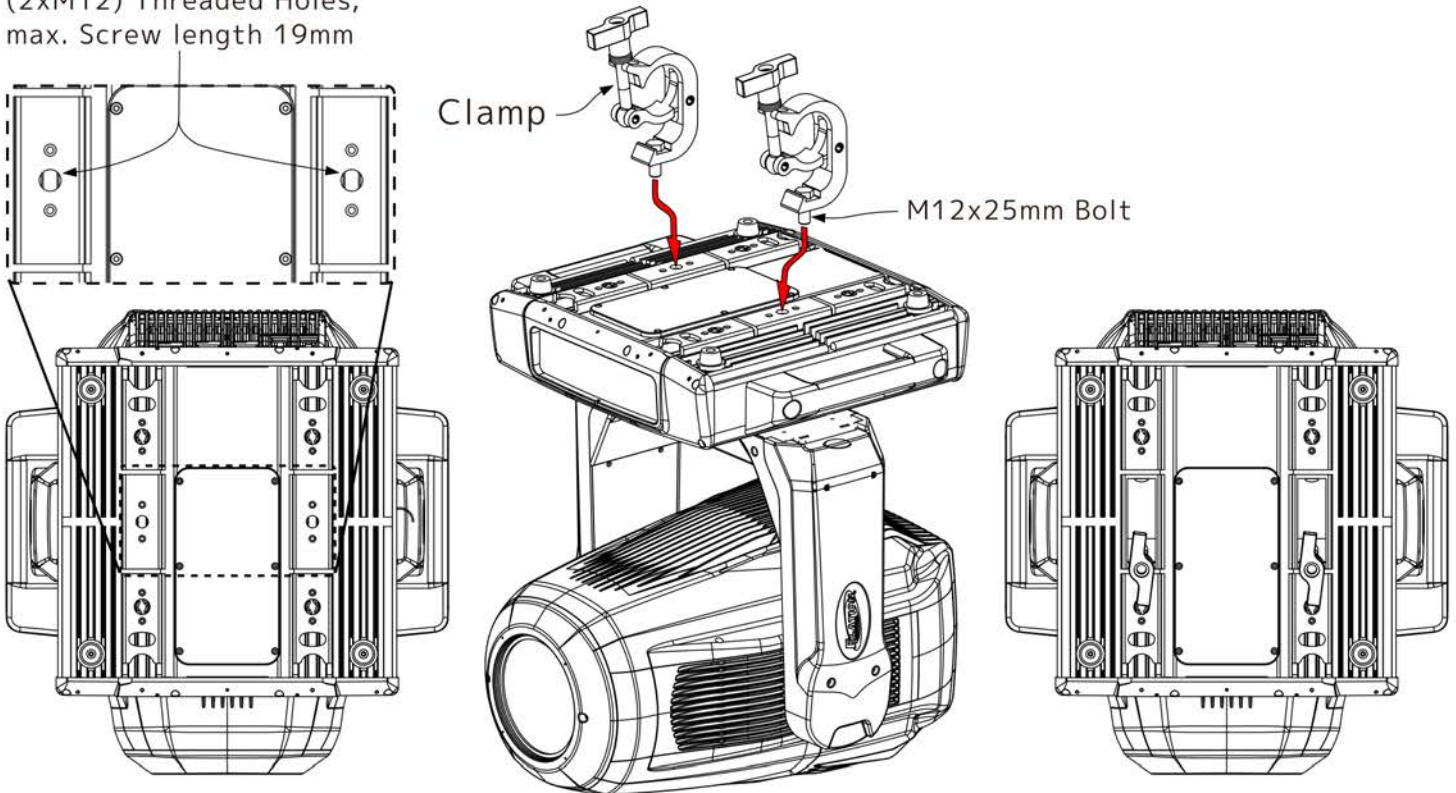

Route Safety Cable through
Safety Cable Attachment
Points and around truss

MOUNTING THE FIXTURE ON A TRUSS USING CLAMPS

When mounting the fixture to a truss, be sure to secure an appropriately rated professional grade rigging clamp to the bottom of the fixture using (2x) minimum grade 8.8 steel (2x) M12x25mm bolts fitted through the mounting hole of the Clamp. The fixture provides built-in rigging points for a SAFETY CABLE (not included). Be sure to only use one of the designated rigging points for the safety cable and never secure a safety cable to a carrying handle.

INSTALLATION GUIDELINES

RIGGING

Overhead rigging requires extensive experience, including among others calculating working load limits, installation material being used, and periodic safety inspection of all installation material and the fixture. If you lack these qualifications, do not attempt the installation yourself. Improper installation can result in bodily injury.

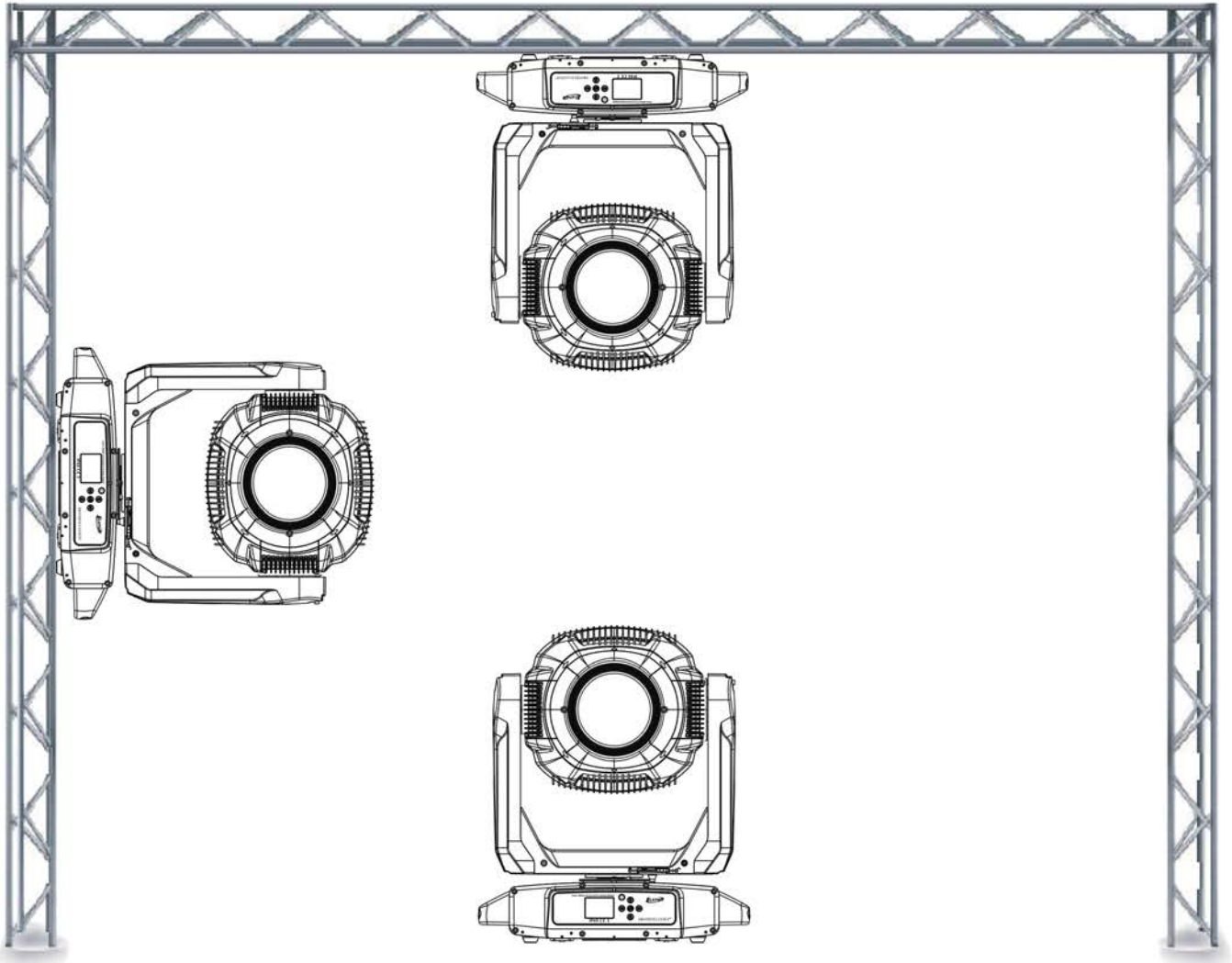

CAUTION: Falling fixtures can cause severe injury or serious equipment damage!



For this reason, fixtures should be installed and inspected only by qualified personnel. Do not install the unit if you lack the qualifications to do so, or if you have doubts about the safety and security of the installation setup or location!

INSTALLATION GUIDELINES

ART-NET | sACN CONNECTION

When connecting fixture to a network switch to control multiple devices, a **Gigabit Ethernet Switch** that supports **IGMP (Internet Group Management Protocol)** is required. Using a **Gigabit Ethernet Switch** that does not support **IGMP** can cause erratic behavior of all connected devices to the switch. Click link below for more information about IGMP.

https://en.wikipedia.org/wiki/Internet_Group_Management_Protocol

POWER AND DATA CABLES



TO MAINTAIN THE IP65 RATING INTEGRITY OF THE FIXTURE, ALL CABLES MUST BE RUN TOWARDS THE GROUND TO PREVENT WATER ACCUMULATION AROUND THE CONNECTIONS.

SYSTEM MENU LCD DISPLAY

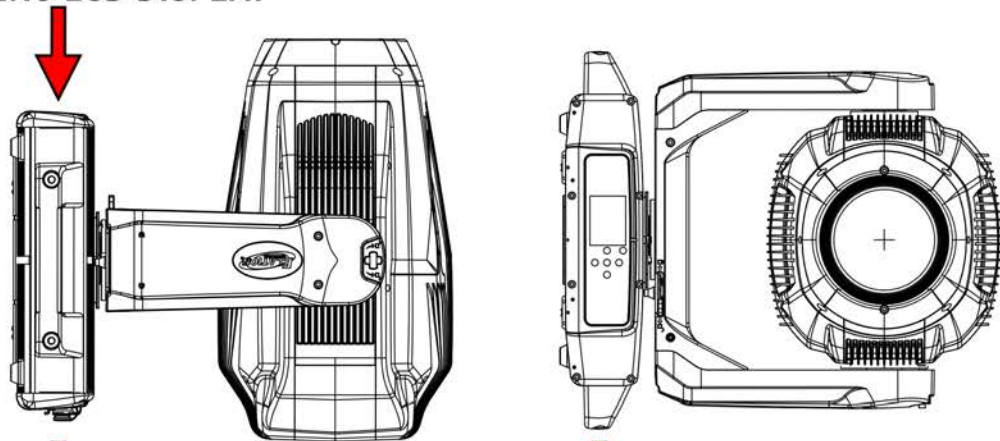

CABLES

CABLES

INCLUDED RJ45 DATA CABLE



THE INCLUDED RJ45 DATA CABLE IS FOR FIXTURE TO FIXTURE INTERCONNECTION ONLY! THE RJ45 CABLE CONNECTORS MAY NOT BE COMPATIBLE WITH OTHER RJ45/ETHERCON TYPE CONNECTORS.

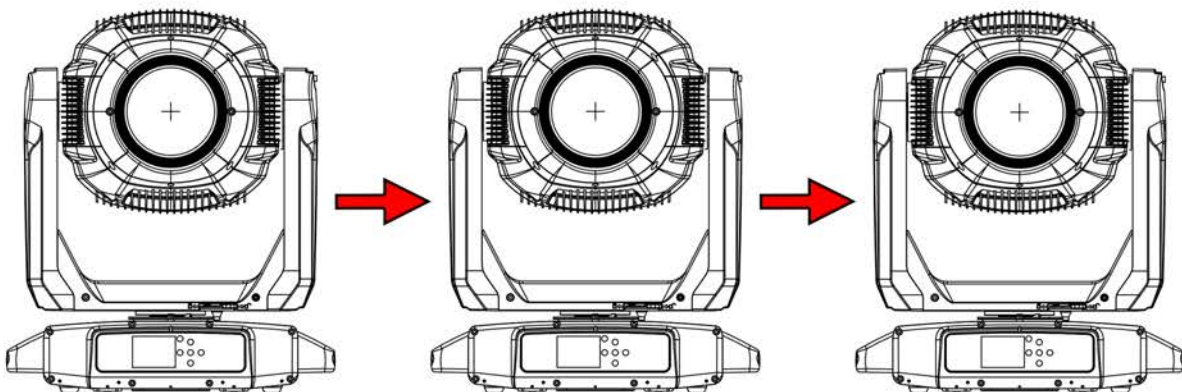

INSTALLATION GUIDELINES

POWER AND DATA CABLES



ENSURE ALL CONNECTIONS AND ENDCAPS ARE PROPERLY SEALED WITH DIELECTRIC GREASE (AVAILABLE AT MOST ELECTRICAL SUPPLIERS) TO PREVENT WATER CORROSION AND/OR ELECTRICAL SHORT CIRCUIT.



TO MAINTAIN THE IP65 RATING INTEGRITY OF THE FIXTURE AND PREVENT WATER FROM ENTERING THE FIXTURE, SEAL ALL UNUSED CONNECTION RUBBER CAPS.

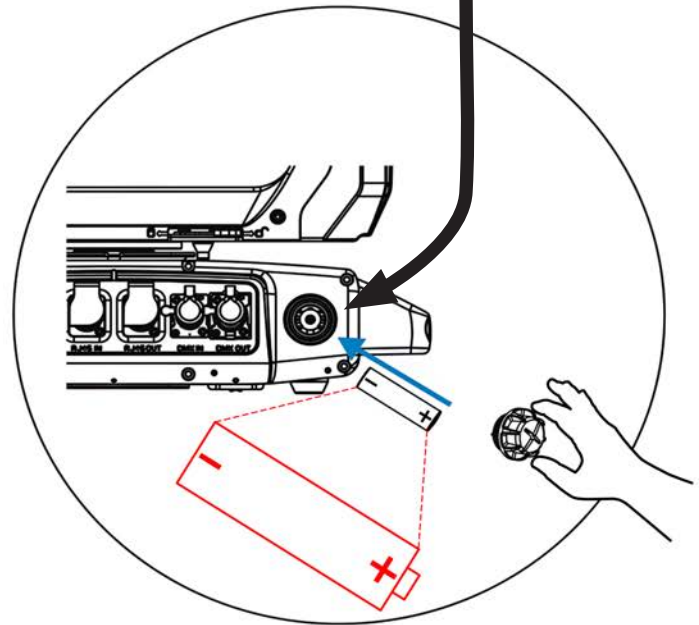
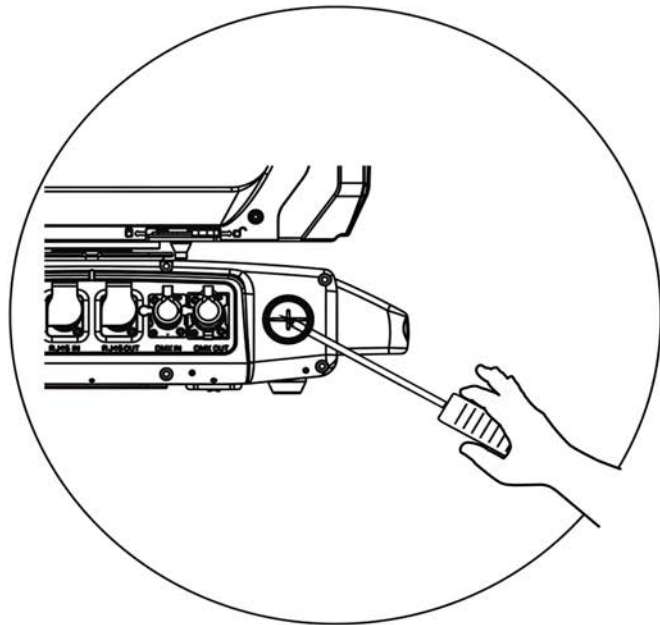
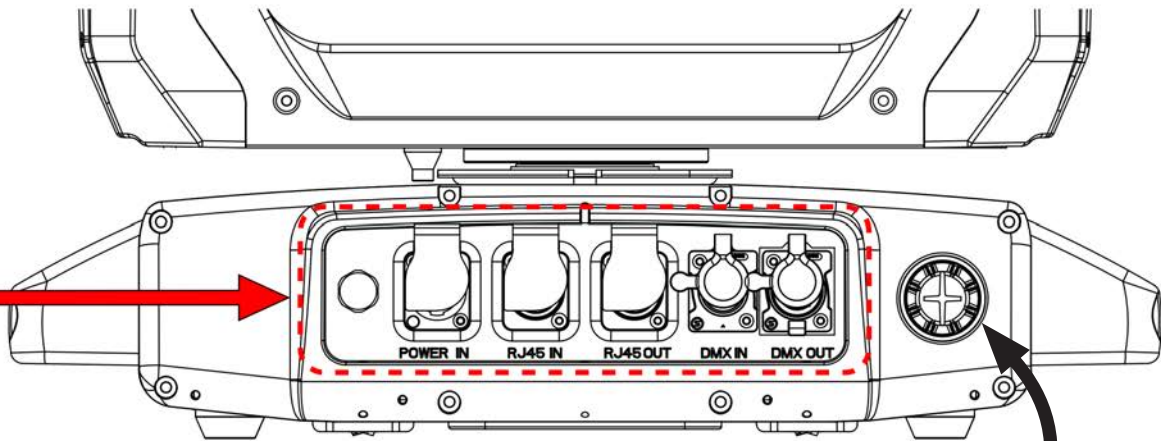

BATTERY REPLACEMENT



Installing the battery incorrectly, in the wrong orientation, where the Plus (+) is inside and Negative (-) is outside, will lead to internal electronics and battery damage. A qualified electrician should be used for all electrical connections and/or installations.

1. Loosen the screw cap for the battery compartment.
2. Remove old battery and replace (inside "-", and outside "+").

NOTE: Replace the battery only with an Li-ion battery (IRC14500/700mAh), which can be ordered from the Elation Parts Website <https://parts.elationlighting.com/catalog/product/view/id/18373/s/60420050026/category/2/>

3. Replace and tighten screw cap for the battery compartment.

INSTALLATION GUIDELINES

POTENTIAL INTERNAL FIXTURE DAMAGE FROM EXTERNAL SOURCES OF LIGHT BEAMS

External sources of light beams from direct sunlight, lighting moving head fixtures, and lasers, which are focused directly towards the exterior housing and/or penetrate the front lens opening of ELATION lighting fixtures, can cause severe internal damage including burning to optics, dichroic color filters, glass and metal gobos, prisms, animation wheels, frost filters, iris, shutters, motors, belts, wiring, discharge lamps, and LEDs.

This issue is not specific only to ELATION lighting fixtures, it is a common issue with lighting fixtures from all manufacturers. Although there is no true way to fully prevent this issue from happening, the guidelines below can prevent any potential damage from occurring if followed. Contact ELATION Service for more details.

DO NOT EXPOSE THE FIXTURE AND/OR FRONT LENS OPENING TO LIGHT BEAMS FROM DIRECT SUNLIGHT, OTHER LIGHTING MOVING HEAD FIXTURES, AND LASERS WHILE UNPACKING, INSTALLATION, USE, AND EXTENDED IDLE TIMES OUTDOORS. DO NOT FOCUS A LIGHT BEAM FROM ONE LIGHTING FIXTURE DIRECTLY TOWARDS ANOTHER.

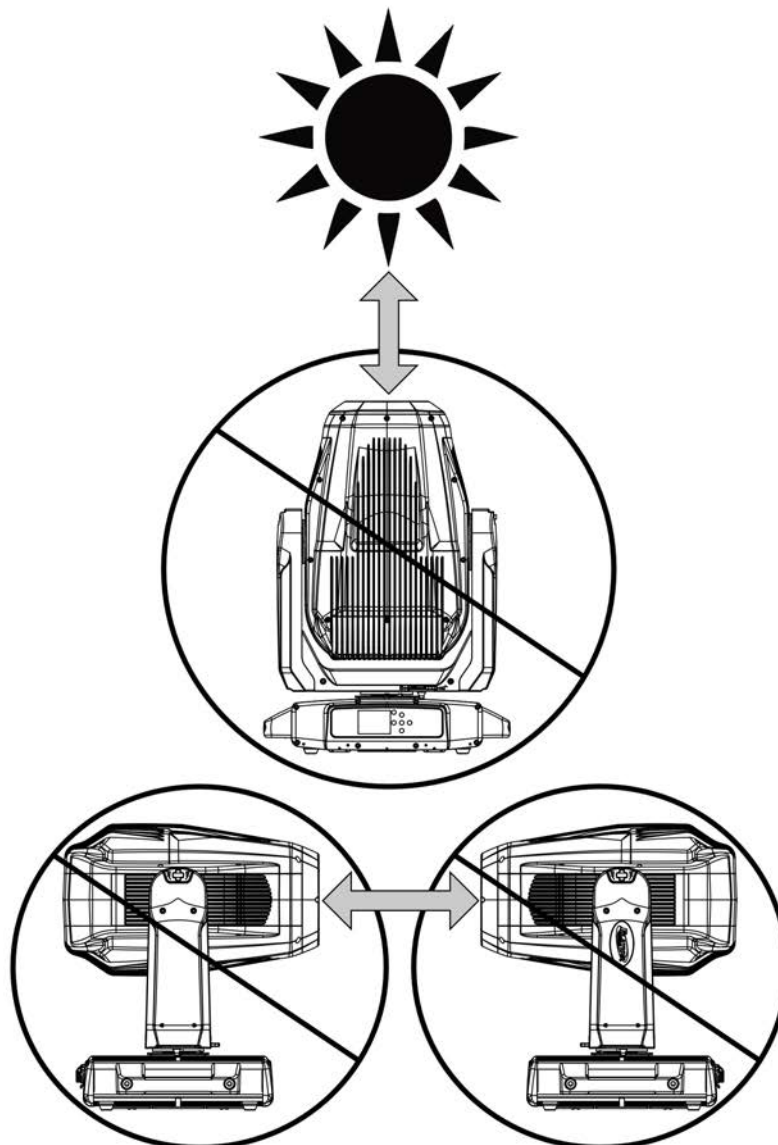

SUN PROTECTION MODE

The fixture incorporates an automatic protection from harmful sunlight, which can damage a fixture's internal components from extended exposure. Fixtures use an internal sensor to determine their physical orientation, then reorient the fixture towards the ground to prevent sunlight from entering the lens.

This automatic feature only works when the fixture is powered. If the fixture is unpowered during setup, it is necessary to manually reorient the lenses away from the sun, and aim them towards the ground. Even a few minutes of sun exposure can cause damage inside the fixture.

The Sun Protection setting is accessed via the "No DMX Status" menu.

The automatic sun protection positioning is activated under the following conditions:

1. Power on without DMX signal: the fixture always starts in sun protection mode.
2. No DMX Status "Sun Protection": the fixture enters sun protection mode after approximately 3 minutes.
3. Remote DMX control: the sun protection position can be **temporarily** activated from the lighting console without the need to create a custom position preset. The fixture senses the correct ground orientation. This means that fixtures already facing the ground may not move their heads.

Hold "Sun Protect Position" for 3s to set the fixture to the sun protection position.

Sun protection status displays as "**Sun Protection: Active**".

The sun protection position deactivates under the following conditions:

1. Connect DMX signal.
2. Remote DMX control: Hold "Sun Protection Off" for 3s.

To avoid harsh or jarring movements, the sun protection position always uses a 5-second fade time when it is activated or deactivated.

HIBERNATION MODE

To reduce wear on the fixture and its components, this mode disables motors and most electronics. Set the hibernation mode countdown time in the Display Menu: "Status Settings / Personality / Hibernation". Hibernation can be fully disabled.

The hibernation mode activates under the following conditions:

1. Loss of DMX: the fixture enters hibernation after the timeout expires. Default is 15 minutes.
2. Remote DMX control: Hold "Hibernate Fixture" for 3s

The hibernation mode deactivates under the following conditions:

1. Connect DMX Signal
2. Remote DMX control: Hold "Hibernate Off" for 3s

The fixture will perform a full calibration cycle, then assume the current DMX status.

Please note that the Hibernation does not change the PT position of the fixtures, allowing the user to set the desired position and then issue the Hibernate command.

To ensure the fixture is protected from harmful sunrays it is recommended to either leave the "No DMX Status" in "Sun Protection" (so the fixture is already in the correct position after 3 minutes of DMX loss) or set the fixture to a safe Tilt position manually first before hibernation.

Burn and heat damage to the fixture's interior components due to external light sources (sun or other fixtures shining into the lens) is never covered under the manufacturers warranty.

SYSTEM MENU

The fixture includes an easy to navigate system menu. The control panel (see image below) located on the front of the fixture, provides access to the main system menu and is where all necessary system adjustments are made to the fixture. During normal operation, pressing **MODE/ESC** button once will access the fixture's main menu. Once in the main menu you can navigate through the different functions and access the sub-menus with the **UP, DOWN, RIGHT,** and **LEFT** buttons. Once you reach a field that requires adjusting, press the **ENTER** button to activate that field and use the **UP** and **DOWN** buttons to adjust the field. Pressing the **ENTER** button once more will confirm your setting. You may exit the main menu at any time without making any adjustments by pressing the **MODE/ESC** button.

NOTE: To access the LCD Menu Control Display via the internal battery, press and hold the **MODE/ESC** button for 10 seconds. The LCD Menu Control Display will shut **OFF** automatically about 1 minute from the last button press.

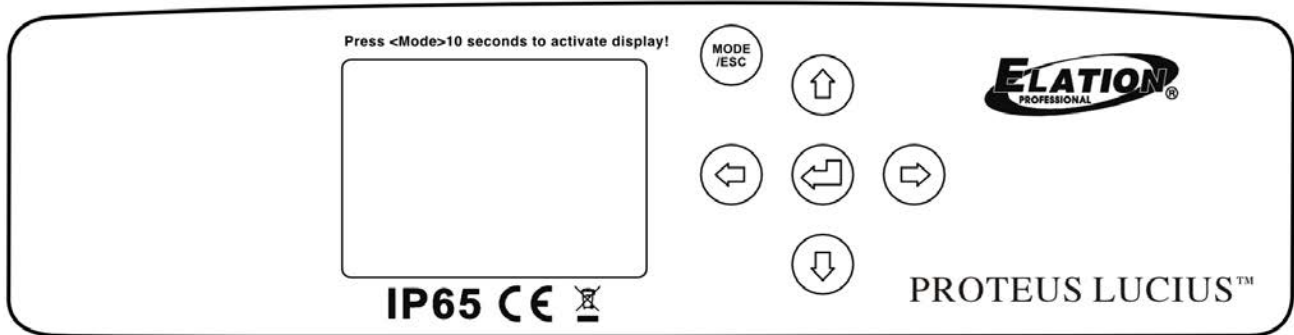

AN ELATION E-LOADER III CAN BE USED TO UPDATE THE FIXTURE TO THE LATEST SOFTWARE. TO ORDER THIS DEVICE, PLEASE CONTACT ELATION SUPPORT FOR FURTHER DETAILS.

**ELATION SERVICE USA - Monday - Friday 8:00am to 4:30pm PST
323-582-3322 | Fax 323-832-9142 | support@elationlighting.com**

**ELATION SERVICE EUROPE - Monday - Friday 08:30 to 17:00 CET
+31 45 546 85 63 | Fax +31 45 546 85 96 | support@elationlighting.eu**

SYSTEM MENU

MAIN MENU	OPTIONS / VALUES (Default Settings in BOLD)		DESCRIPTION	
Function	Set Dmx Address	A001~AXXX	DMX Address Setting	
	Dmx Value	PAN.....	DMX Value Display	
	Secondary Mode	Secondary1, Secondary2, Secondary3	Secondary Setting	
	Auto Program	Primary / Alone	Auto Program	
Information	Time Information	Current Time	XXXX(Hours)	Power On Running Time
		Total Run Time	XXXX(Hours)	Fixture Running Time
		Last Run Time	XXXX(Hours)	Fixture Last Times Clear
		LastRun Password	Password=XXX	Timer Password 038
		Clear Last Run	ON/OFF	Clear Fixture Last Time
	Temperature Info	LED Temperature	XXX°C/°F	Temperature in LED
		Base Temperature	XXX°C/°F	Temperature in Base
		Head Temperature	XXX°C/°F	Temperature in Fixture
	Humidity Info	Base Humidity	XXX%	Humidity in Base
		Head Humidity	XXX%	Humidity in Fixture
	Ethernet IP	Ethernet IP XXX. XXX. XXX. XXX XXX. XXX. XXX. XXX	Ethernet IP	
	Fan Info	HeadFan1: xxxx RPM	Fan information	
	Software Version	Vx.x.x		
	Error Info	Error Record 1 Error Record 2 Error Record 10	Software Version	
Personality	Status Settings	Address Via DMX	ON/OFF	Address Via DMX
		No DMX Status	Close/Hold/Auto/ SunProt	Auto Run If No DMX
		Pan Reverse	ON/OFF	Pan Reverse movement
		Tilt Reverse	ON/OFF	Tilt Reverse movement
		Pan Degree	630/ 540	Pan Degree Select
		Feedback	ON/OFF	Movement Feedback
		Movement Speed	Normal /Slow	Movement Speed
		CMY Speed	Normal/ Fast	Adjust CMY speed
		P/T Brake Mode	Smooth /Fast	P/T Brake Mode
		Gobo Color Cor.	Enable /Disable	Cobo Color Correction
		Hibernation	OFF, 01M~99M, 15M	Standby Mode
	Service Setting	Password	Password=XXX	Password"=050"
		Clear Err. Info	ON/OFF	Clear Err. Info
	Fans Control	Auto / High/ Low/ Studio/ Mute	Fans Control	
	Display Setting	Shutoff Time	02~60m 05m	Display Shut Off Time
		Display Reverse	OFF/ ON/AUTO	Reverse 180 degree
		Key Lock	ON/OFF	LCD Control Panel Key Lock

SYSTEM MENU

MAIN MENU	OPTIONS / VALUES (Default Settings in BOLD)		DESCRIPTION	
Personality	Temperature C/F	Celsius	Temp C/F	
		Fahrenheit		
	Initial Status	PAN =XXX ...	Initial effect position	
	Select Signal	DMX Only	Select Signal	
		Art-Net		
		sACN		
	Ethernet IP	XXX. XXX. XXX. XXX	Ethernet IP	
	Ether Mask IP	XXX. XXX. XXX. XXX	Ether Mask IP	
	Set Universe	000~32767	Setting Art-Net Universe	
	Dimmer Mode	Standard	Dimmer Mode	
		Stage		
TV				
Architectural				
Theatre				
Stage2				
	Delay 0s, 0.1s, 0.2s, ..., 10s			
Refresh	1200 , 900-1500, 2500, 4000, 5000, 6000, 10000, 15000, 20000, 25000(Hz)	Refresh Frequency Rate Setting		
DimmerCurve	Linear , Square, InverseSquare, S-Curve	DimmerCurve Setting		
ResetDef	ON	PassCode (011)	Restore factory settings Password = " 011 "	
	Off			
Reset Function	Reset All		Reset Function	
	Reset Pan&Tilt			
	Reset Colors			
	Reset Gobos			
	ResetZoomModules			
	Reset Others			
Effect Adjust	Test Channel	Pan = XXX :	Test function	
	Manual Control	Pan = XXX :	Manual adjustment	
	Calibration	Calibrate Password Pan=XXX :	Password = " 050 " Calibrate and adjust the effects to standard/right position	
User Mode Set	User Mode	Standard Mode Extended Mode	User's mode to change channel numbers	
Edit Program	Select Program	Auto Pro Part 1 = Program 1 ~ 10 Program 1	Select Programs To Be Run	
		Auto Pro Part 2 = Program 1 ~ 10 Program 1		
		Auto Pro Part 3 = Program 1 ~ 10 Program 1		
	Edit Program	Prog 1 : Prog 10	ProgTest	Testing Program
			Step 01 = SCxxx	Program In Loop
			SStep 64 = SCxxx	Save and Exit
Edit Scenes	Edit Scene 001 ~ Edit Scene 250	Pan, Tilt, - Fade Time - - Scene Time - Input By Out	Save and Automatically Return Manual Scenes Edit	
Rec. Controller	XX~XX		Automatic Scenes Recorder	

SYSTEM MENU

FUNCTION - Auto Program

Define fixture mode (Primary or Alone) for running Auto Programs. Select desired internal programs under "Select Program", set the number of steps under "Edit program", and edit individual scenes under "Edit Scenes".

PERSONALITY - Status Settings - Address Via DMX

When ON, define the desired DMX address via an external controller.

NOTE: This process assumes the fixture DMX address is set to 001. If fixture DMX address is not at 001, you must adjust the channel numbers accordingly in order for this feature to work. For example: if your fixture address is 010, then Channel 1 becomes Channel 10, Channel 2 becomes Channel 11, and Channel 3 becomes Channel 12.

1. Connect the fixture to the external controller and power ON.
2. Set the DMX value of Channel 1 on the controller to (7).
3. Set the DMX value of Channel 2 on the controller to (7) or (8). When set to (7), the DMX address can be set between (1) and (255). When set to (8), the DMX address can be set between (256) and (511).
4. Using Channel 3 on the controller set the desired DMX address of the fixture.

Example 1:

If the desired DMX address is 57, set Channel 1 to a value of (7), set Channel 2 to a value of (7), and then set Channel 3 to a value of (57).

Example 2:

If the desired DMX address is 420, set Channel 1 to a value of (7), set Channel 2 to a value of (8), and then set Channel 3 to a value of (164). (256+164=420)

5. After setting Channel 3 to the desired DMX address value, wait approximately 20 seconds for the fixture to complete the address reset function.

PERSONALITY - Status Settings - Movement Speed

Select Movement Speed (Normal, Slow).

NOTE: For hanging position only use slow speed

PERSONALITY - Service Settings - Password (050)

NOTE: The Service Password MUST be entered in order to access the following menus:

Clear Err. Info .

PERSONALITY - Display Setting - Key Lock

When ON, Control Panel buttons lock automatically after exiting main menu for 15 seconds. To unlock, keep MODE/ESC button pressed for 3 seconds.

PERSONALITY - Dimmer Curve

Select dimming curve (Linear, Square, InverseSquare, S-Curve).

PERSONALITY - Reset Default (011)

SYSTEM MENU



ONLY QUALIFIED TECHNICIANS SHOULD PERFORM THIS FUNCTION!
NOTE: SAVED WHITE BALANCE IS ERASED AFTER A RESET IS PERFORMED!

This function restores all fixture settings to the factory default settings. The password is 011 and must be entered each time a reset is performed.

EFFECT ADJUST - Test Channel

Auto test each individual channel function independently from the DMX control board.

EFFECT ADJUST - Manual Control

Select and manually test and fine adjust each individual channel function Independently from DMX control board. This function will center PAN and TILT motors and set dimmer to 100%. PAN and TILT functions will still operate if the fixture needs to be positioned to a flat clear surface. With the individual functions, you can focus the light on a flat surface (wall) and perform fine adjustments.



EFFECT ADJUST - Calibration
ONLY QUALIFIED TECHNICIANS SHOULD PERFORM THIS FUNCTION.

This function allows small adjustments to be made to the Pan, Tilt, and Zoom movements to compensate for wear or in the event a sensor has been knocked slightly out of place. Because improper use of this function can result in undesired operation this function has been password protected. The password is 050 and must be entered each time the calibration menu function is entered. Because calibration is an extremely delicate procedure, instructions on performing this action are left out of this manual. For a first-time calibrator, please contact our customer support team for step-by-step instructions.

EDIT PROGRAM - Rec. Controller

The fixture features an integrated DMX-recorder by which you can transmit the programmed scenes from your DMX-controller to the moving head. Adjust the desired scene numbers via the encoder (from – to). When you call up the scenes at your controller, they will automatically be transmitted to the moving head.

SYSTEM MENU

EDIT PROGRAM - Record Controller - Working With Built - In Programs

A Primary unit can send up to 3 different data groups to the Secondary units, i.e. a Primary unit can start 3 different Secondary units, which run 3 different programs. The Primary unit sends the 3 program parts in a continuous loop.



The Secondary unit receives data from the Primary unit according to the group which the Secondary unit was assigned to. If e.g. a Secondary unit is set to "Secondary 1" in the menu "Set to Secondary", the Primary unit sends "Auto Program Part 1" to the Secondary unit. If set to "Secondary 2", the Secondary unit receives "Auto Program Part 2".

To start an Auto Program proceed as follows:

1. Secondary Setting
 - Select "Function Mode".
 - Press ENTER to confirm.
 - Select "Set to Secondary".
 - Press ENTER to confirm.
 - Select "Secondary 1", "Secondary 2" or "Secondary 3".
 - Press ENTER to confirm.
 - Press MODE/ESC in order to return to the main menu.
2. Automatic Program Run
 - Select "Function Mode".
 - Press ENTER to confirm.
 - Select "Auto Program".
 - Press ENTER to confirm.
 - Select "Primary" or "Alone".
 - Press ENTER to confirm.
 - Press MODE/ESC in order to return to the main menu.

SYSTEM MENU

EDIT PROGRAM - Record Controller - Working With Built-In Program [continued]

3. Program Selection for Auto Pro Part
 - Select "Edit Program".
 - Press ENTER to confirm.
 - Select "Select Programs".
 - Press ENTER to confirm.
 - Select "Auto Pro Part 1", "Auto Pro Part 2" or "Auto Pro Part 3", and select which Secondary program is to be sent. Selection "Part 1" means, that the Secondary unit runs the same program as the Primary units.
 - Press ENTER to confirm.
 - Press MODE/ESC in order to return to the main menu.
4. Program Selection for Edit Program
 - Select "Edit Program".
 - Press ENTER to confirm.
 - Select "Edit Program".
 - Press ENTER to confirm.
 - Select the desired program to edit specific scenes into a specific program.
 - Press ENTER to confirm.
 - Press MODE/ESC in order to return to the main menu.
5. Automatic Scene Recording
 - Select "Edit Program".
 - Press ENTER to confirm.
 - Select "Edit Scenes".
 - Press ENTER to confirm.
 - Select desired scene numbers. A maximum of 250 scenes can be programmed.
 - Press ENTER to confirm.
 - Press MODE/ESC in order to return to the main menu.

EDIT PROGRAM - Record Controller - Working With Built - In Program [continued]

Example:

Program 2 includes scenes: 10, 11, 12, & 13

Program 4 includes scenes: 8, 9, & 10

Program 6 includes scenes: 12, 13, 14, & 15

Auto Pro Part 1 is Program 2

Auto Pro Part 2 is Program 3

Auto Pro Part 3 is Program 6

The 3 Secondary groups run the Auto Program in certain time segments.

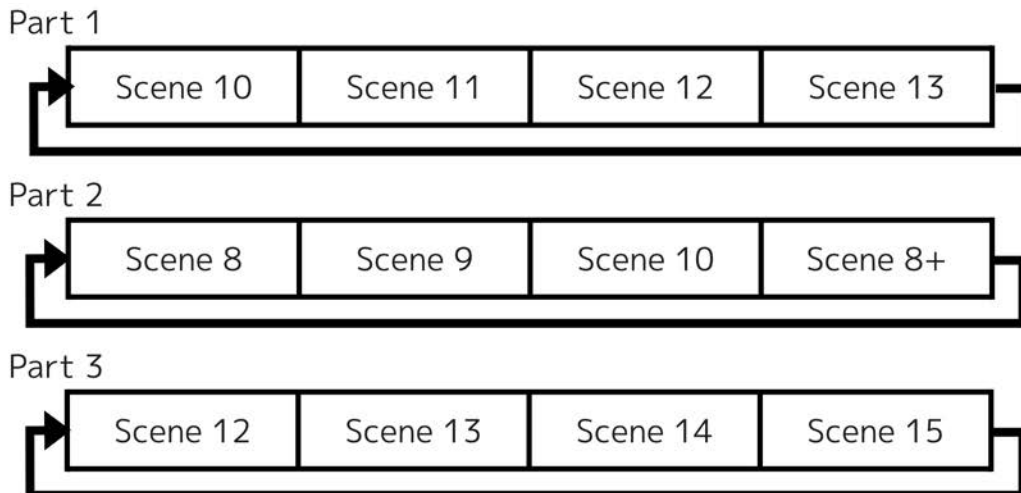

DIMMER MODE / DIMMER CURVES

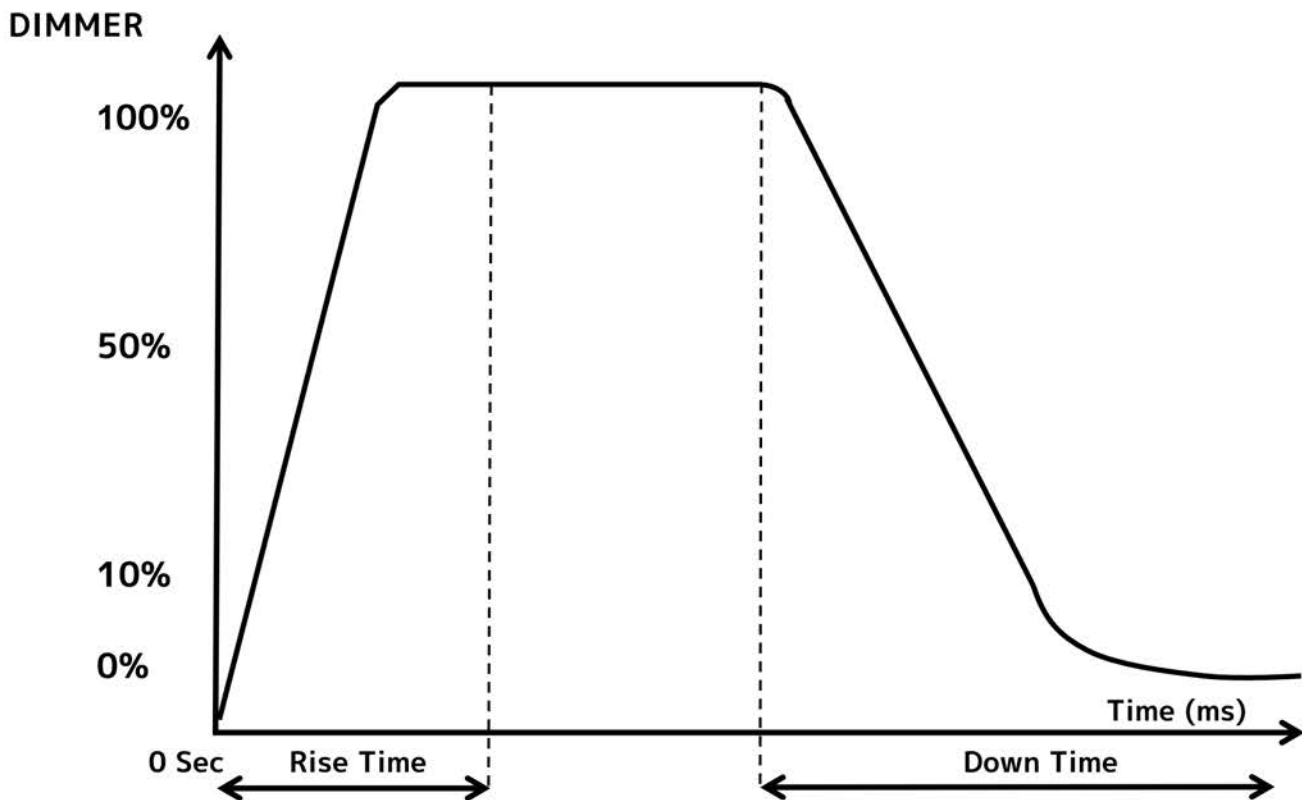

Dimming Curve Ramp Effect	0 sec Fade Time		1 sec Fade Time	
	Rise Time (ms)	Down Time (ms)	Rise Time (ms)	Down Time (ms)
Standard (default)	0	0	0	0
Stage	780	1100	1540	1660
TV	1180	1520	1860	1940
Architectural-	1380	1730	2040	2120
Theatre	1580	1940	2230	2280
Stage 2	0	1100	0	1660

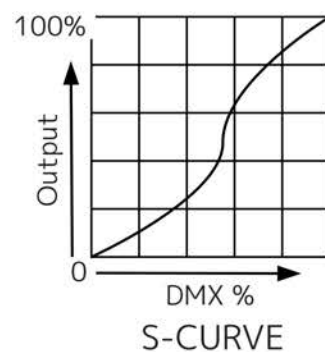
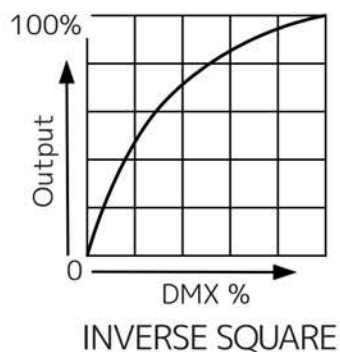
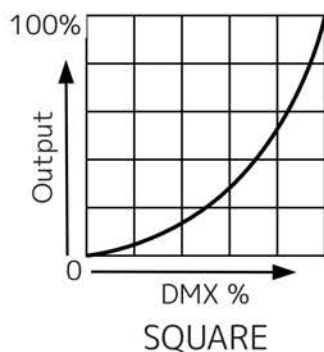
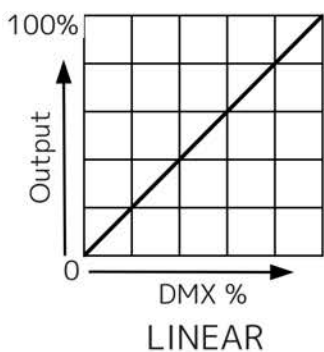

DMX TRAITS: CHANNEL FUNCTIONS & VALUES

Features subject to change without notice						
MODE/CHANNEL		VALUE	FUNCTION	HOLD TIME	DEFAULT	SNAP
STANDARD	EXTENDED					
1	1		PAN Movement 8bit:		127	
		0-255	Pan Movement			
2	2		Pan Fine 16bit:		127	
		0-255	Fine control of Pan movement			
3	3		TILT Movement 8bit:		127	
		0-255	Tilt Movement			
4	4		Tilt Fine 16bit:		127	
		0-255	Fine control of Tilt movement			
5	5		Cyan:			
		0-255	Cyan (0-100% Cyan)			
	6		Cyan Fine:			
		0-255	Cyan Fine			
6	7		Magenta:			
		0-255	Magenta (0-100% Magenta)			
	8		Magenta Fine:			
		0-255	Magenta Fine			
7	9		Yellow:			
		0-255	Yellow (0-100% Yellow)			
	10		Yellow Fine:			
		0-255	Yellow Fine			
8	11		CTO:			
		0-255	CTO (0-100% CTO)			
	12		CTO Fine:			
		0-255	CTO Fine			
9	13		Color Wheel:			X
		0-7	Open			
		8-31	Red			
		32-55	Green			
		56-79	High CRI			
		80-103	Orange			
		104-127	Medium Blue			
		128-189	Clockwise effect from fast to slow			
		190-193	No rotation			
194-255	Counter-clockwise effect from slow to fast					
	14		Color Wheel Fine:			X
		0-255	Fine Control of Color Wheel position			

Features subject to change without notice

MODE/CHANNEL		VALUE	FUNCTION	HOLD TIME	DEFAULT	SNAP	
STANDARD	EXTENDED						
10	15		Rotating Gobo 1				
		0-9	Open				
		10-19	Rot. gobo 1				
		20-29	Rot. gobo 2				
		30-39	Rot. gobo 3				
		40-49	Rot. gobo 4				
		50-59	Rot. gobo 5				
		60-69	Rot. gobo 6				
		70-89	Gobo 1 shake slow to fast				X
		90-109	Gobo 2 shake slow to fast				
		110-129	Gobo 3 shake slow to fast				
		130-149	Gobo 4 shake slow to fast				
		150-169	Gobo 5 shake slow to fast				
		170-189	Gobo 6 shake slow to fast				
		190-221	Scroll CW fast to slow				
		222-223	Stop				
224-255	Scroll CCW slow to fast						
11	16		Rotating Gobo1 Index, Rotation				
		0-127	Gobo indexing				
		128-189	Clockwise gobo scroll from fast to slow				
		190-193	No rotation				
194-255	Counter-clockwise gobo scroll from slow to fast						
12	17		Rotating gobo1 fine indexing:				
		0-255	Fine indexing				
13	18		Rotating Gobo 2				
		0-9	Open				
		10-19	Rot. gobo 1				
		20-29	Rot. gobo 2				
		30-39	Rot. gobo 3				
		40-49	Rot. gobo 4				
		50-59	Rot. gobo 5				
		60-69	Rot. gobo 6				
		70-77	Rot. gobo 7				
		78-93	Gobo 1 shake slow to fast				X
		94-109	Gobo 2 shake slow to fast				
		110-125	Gobo 3 shake slow to fast				
		126-141	Gobo 4 shake slow to fast				
		142-157	Gobo 5 shake slow to fast				
		158-173	Gobo 6 shake slow to fast				
174-189	Gobo 7 shake slow to fast						
190-221	Scroll CW fast to slow						
222-223	Stop						
224-255	Scroll CCW slow to fast						

Features subject to change without notice						
MODE/CHANNEL		VALUE	FUNCTION	HOLD TIME	DEFAULT	SNAP
STANDARD	EXTENDED					
14	19		Rotating Gobo2 Index, Rotation			
		0-127	Gobo indexing			
		128-189	Clockwise gobo scroll from fast to slow			
		190-193	No rotation			
		194-255	Counter-clockwise gobo scroll from slow to fast			
15	20		Rotating gobo2 fine indexing:			
		0-255	Fine indexing			
16	21		Fixed gobo			
		0-9	Open			
		10-19	Gobo 1			
		20-29	Gobo 2			
		30-39	Gobo 3			
		40-49	Gobo 4			
		50-59	Gobo 5			
		60-69	Gobo 6			
		70-77	Gobo 7			
		78-93	Gobo 1 shake slow to fast			
		94-109	Gobo 2 shake slow to fast			
		110-125	Gobo 3 shake slow to fast			
		126-141	Gobo 4 shake slow to fast			
		142-157	Gobo 5 shake slow to fast			
		158-173	Gobo 6 shake slow to fast			
		174-189	Gobo 7 shake slow to fast			
				190-221	Clockwise gobo scroll from fast to slow	
		222-223	No rotation			
		224-255	Counter-clockwise gobo scroll from slow to fast			
	22		Fixed gobo indexing Fine:			
		0-255	Fine indexing			X
17	23		Rotating prism, Prism/Gobo macros:			
		0-63	Open			
		64-127	4 Facet Prism			
		128-135	Macro1			
		136-143	Macro2			
		144-151	Macro3			
		152-159	Macro4			
		160-167	Macro5			
		168-175	Macro6			
		176-183	Macro7			
		184-191	Macro8			
		192--199	Macro9			
		200-207	Macro10			
		208-215	Macro11			
		216-223	Macro12			
		224-231	Macro13			
232-239	Macro14					
240-247	Macro15					
248-255	Macro16					

Features subject to change without notice

MODE/CHANNEL		VALUE	FUNCTION	HOLD TIME	DEFAULT	SNAP
STANDARD	EXTENDED					
18	24		Rotating 4 prism Index, Rotating gobo rotation:			
		0-127	Prism indexing			
		128-189	Clockwise prism rotation from fast to slow			
		190-193	No rotation			
		194-255	Counter-clockwise prism rotation from slow to fast			
	25		Rotating 4 prism indexing Fine:			
		0-255	Fine indexing			
19	26		Rotating 4 prism linear:			
		0-63	Open			X
		64-255	4 Facet Linear Prism			
20	27		4 Prism Linear index, rotating gobo rotation:			
		0-127	Prism indexing			
		128-189	Clockwise prism rotation from fast to slow			
		190-193	No rotation			
		194-255	Counter-clockwise prism rotation from slow to fast			
	28		4 Prism Linear indexing Fine :			
		0-255	Fine indexing			
21	29		Focus:		127	
		0-255	Focus edge adjustment			
22	30		Focus Fine:		127	
		0-255	Focus adjustment Fine			
23	31		Zoom:		127	
		0-255	Zoom adjustment from small to big			
24	32		Zoom Fine:		127	
		0-255	Zoom adjustment Fine			
	33		Auto Focus :			
		0-50	Auto Focus Off			
		51-100	5m			X
		101-150	7.5m			
		151-200	10m			
		201-255	15m			
	34		AutoFocus Fine:			
		0-255	Continuous adjustment Fine			
25	35		Shutter, strobe:		50	
		0-31	Shutter closed			
		32-63	No function (shutter open)			
		64-95	Strobe effect slow to fast			
		96-127	No function (shutter open)			
		128-159	Pulse-effect in sequences			
		160-191	No function (shutter open)			
		192-223	Random strobe effect slow to fast			
		224-255	No function (shutter open)			
26	36		Dimmer:			
		0-255	Intensity 0 to 100%			
27	37		Dimmer Fine:			
		0-255	Dimmer fine			

Features subject to change without notice						
MODE/CHANNEL		VALUE	FUNCTION	HOLD TIME	DEFAULT	SNAP
STANDARD	EXTENDED					
28	38		Dim Modes	0		X
		0-20	Standard			
		21-40	Stage			
		41-60	TV			
		61-80	Architectural			
		81-100	Theatre			
		101- 120	Stage 2			
			Dimmer Delay Time			
		121	0s			
		122	0.1s			
		123	0.2s			
		124	0.3s			
		125	0.4s			
		126	0.5s			
		127	0.6s			
		128	0.7s			
		129	0.8s			
		130	0.9s			
		131	1.0s			
		132	1.5s			
		133	2.0s			
		134	3.0s			
		135	4.0s			
136	5.0s					
137	6.0s					
138	7.0s					
139	8.0s					
140	9.0s					
141	10s					
142 - 255	Idle					
29	39		Iris:			
		0-191	Max. diameter to Min. diameter			
		192-223	Pulse opening fast to slow			
		224-255	Pulse closing slow to fast			
	40		Iris Fine:			
		0-255	Iris Fine			
30	41		Frost1:			
		0-255	0-100% Linear Frost1			
31	42		Frost2:			
		0-255	0-100% Linear Frost2			
32	43		Animation wheel:			
		0-7	Open			
		8-255	Animation min to max			
33	44		Animation index, animation rotation:			
		0-127	Animation indexing			
		128-189	Clockwise animation rotation from fast to slow			
		190-193	No rotation			
		194-255	Counter-clockwise animation rotation from slow to fast			
	45		Speed Of CMY & Color macro Speed:			
		0-255	Speed Max -> Min.			

Features subject to change without notice

MODE/CHANNEL		VALUE	FUNCTION	HOLD TIME	DEFAULT	SNAP
STANDARD	EXTENDED					
			Color macros - CMY and color wheel			
		0-31	OFF			
		32-39	Macro1			
		40-47	Macro2			
		48-55	Macro3			
		56-63	Macro4			
		64-71	Macro5			
		72-79	Macro6			
		80-87	Macro7			
		88-95	Macro8			
		96-103	Macro9			
		104-111	Macro10			
		112-119	Macro11			
		120-127	Macro12			
		128-135	Macro13			
	46	136-143	Macro14			X
		144-151	Macro15			
		152-159	Macro16			
		160-167	Macro17			
		168-175	Macro18			
		176-183	Macro19			
		184-191	Macro20			
		192-199	Macro21			
		200-207	Macro22			
		208-215	Macro23			
		216-223	Macro24			
		224-231	Macro25			
		232-239	Macro26			
		240-247	Macro27			
		248-255	Random CMY			

Features subject to change without notice						
MODE/CHANNEL		VALUE	FUNCTION	HOLD TIME	DEFAULT	SNAP
STANDARD	EXTENDED					
34	47		Blade 1A			
		0-255				
	48		Blade 1A Fine			
		0-255				
35	49		Blade 1B			
		0-255				
	50		Blade 1B Fine			
		0-255	Open to Close Fine			
36	51		Blade 2A			
		0-255	Open to Close			
	52		Blade 2A Fine			
		0-255	Open to Close Fine			
37	53		Blade 2B			
		0-255	Open to Close			
	54		Blade 2B Fine			
		0-255	Open to Close Fine			
38	55		Blade 3A			
		0-255	Open to Close			
	56		Blade 3A Fine			
		0-255	Open to Close Fine			
39	57		Blade 3B			
		0-255	Open to Close			
	58		Blade 3B Fine			
		0-255	Open to Close Fine			
40	59		Blade 4A			
		0-255	Open to Close			
	60		Blade 4A Fine			
		0-255	Open to Close Fine			
41	61		Blade 4B			
		0-255	Open to Close			
	62		Blade 4B Fine			
		0-255	Open to Close Fine			
42	63		Framing Rotation:			
		0-126	Min (-45 degrees)			
		127-128	Parallel (0 degrees)			
	64		Framing Rotation Fine:			
		0-255	Framing Rotation Fine			
	65		Framing Speed:			
		0-255	Speed Max -> Min.			

Features subject to change without notice

MODE/CHANNEL		VALUE	FUNCTION	HOLD TIME	DEFAULT	SNAP
STANDARD	EXTENDED					
	66		Framing Macro:			X
		0-7	OFF			
		8-15	Macro1			
		16-23	Macro2			
		24-31	Macro3			
		32-39	Macro4			
		40-47	Macro5			
		48-55	Macro6			
		56-63	Macro7			
		64-71	Macro8			
		72-79	Macro9			
		80-87	Macro10			
		88-95	Macro11			
		96-103	Macro12			
		104-111	Macro13			
		112-119	Macro14			
		120-127	Macro15			
		128-135	Macro16			
		136-143	Macro17			
		144-151	Macro18			
		152-159	Macro19			
		160-167	Macro20			
		168-175	Macro21			
		176-183	Macro22			
		184-191	Macro23			
		192-199	Macro24			
		200-207	Macro25			
		208-215	Macro26			
		216-223	Macro27			
		224-231	Macro28			
		232-239	Macro29			
		240-247	Macro30			
248-255	Macro31					
	67		Pan / Tilt Speed:			X
		0-225	Max to min speed			
		226-235	Blackout by movement			
		236-245	Blackout by all wheel changing			
		246-255	No function			
43	68		Control:	0		
		0-19	Color change normal			
		20-29	Color change to any position			
		30-39	Color & gobo change to any position			
		40-44	Low Noise - Mute			
		45-49	Low Noise - Studio			
		50-59	Fan Control - Low			
		60-69	Fan Control - High			
		70-79	Fan Control - Auto (Default)			
		80-84	All motor reset	3s		
		85-87	Pan / Tilt reset			
		88-90	Color reset			
		91-93	Gobo reset			
		94-96	Focus and Zoom reset			
97-99	Other motor reset					

Features subject to change without notice

MODE/CHANNEL		VALUE	FUNCTION	HOLD TIME	DEFAULT	SNAP
STANDARD	EXTENDED					
43	68	100-168	Refresh Rate (Hz)	1s		X
		100	900			
		101	910			
		102	920			
		103	930			
		104	940			
		105	950			
		106	960			
		107	970			
		108	980			
		109	990			
		110	1000			
		111	1010			
		112	1020			
		113	1030			
		114	1040			
		115	1050			
		116	1060			
		117	1070			
		118	1080			
		119	1090			
		120	1100			
		121	1110			
		122	1120			
		123	1130			
		124	1140			
		125	1150			
		126	1160			
		127	1170			
		128	1180			
		129	1190			
		130	1200			
		131	1210			
		132	1220			
133	1230					
134	1240					
135	1250					
136	1260					
137	1270					
138	1280					
139	1290					
140	1300					
141	1310					
142	1320					

Features subject to change without notice						
MODE/CHANNEL		VALUE	FUNCTION	HOLD TIME	DEFAULT	SNAP
STANDARD	EXTENDED					
43	68	143	1330	1s		X
		144	1340			
		145	1350			
		146	1360			
		147	1370			
		148	1380			
		149	1390			
		150	1400			
		151	1410			
		152	1420			
		153	1430			
		154	1440			
		155	1450			
		156	1460			
		157	1470			
		158	1480			
		159	1490			
		160	1500			
		161	2500			
		162	4000			
		163	5000			
		164	6000			
		165	10000			
		166	15000			
		167	20000			
		168	25000			
		169-170	Gobo Color Correction disable	3s		
		171-172	Gobo Color Correction enable (default)			
		173-174	Hibernation Off			
		175-176	Hibernation			
		177-178	Sun Protection On			
		179-180	Sun Protection Off			
		181-190	PanTilt Smooth (default)			
		191-200	PanTilt Fast			
201-210	Dimmer Curve Linear (default)					
211-220	Dimmer Curve Square					
221-230	Dimmer Curve Inverse Square					
231-240	Dimmer Curve S-Curve					
241	Internal program 1 (scene1~8)					
242	Internal program 2 (scene9~16)					
243	Internal program 3 (scene17~24)					
244	Internal program 4 (scene25~32)					
245	Internal program 5 (scene33~40)					
246	Internal program 6 (scene41~48)					
247	Internal program 7 (scene49~56)					
248-249	CMY Normal					
250-251	CMY Fast (default)					
252-255	Idle					

REMOTE DEVICE MANAGEMENT (RDM)

NOTE: In order for RDM to work properly, RDM enabled equipment must be used throughout the entire system, including DMX data splitters and wireless systems.

Remote Device Management (RDM) is a protocol that sits on top of the DMX512 data standard for lighting, allowing the DMX systems of the device to be managed, modified, and monitored remotely (hence, remote device management). This protocol is ideal for fixtures installed in locations that are not easily accessible.

With RDM, the DMX512 system becomes bi-directional, allowing a compatible RDM enabled controller to send out a signal to devices on the wire, as well as allowing the fixture to respond (known as a GET command). The controller can then use it's SET command to modify settings that would typically have to be changed or viewed directly via the unit's display screen, including the DMX Address, DMX Channel Mode, and Temperature Sensors.

FIXTURE RDM INFORMATION:

RDM Code	Device ID	Device Model ID	Personality ID
0X667	OPEN	1639	OPEN

Please be aware that not all RDM devices support all RDM features, and therefore it is important to check beforehand to ensure that the equipment that you are considering includes all of the features that you require.

The following parameters are accessible in RDM on this device:

LED FIXTURE
Sensor Definition
Sensor Value
Device Model Description
Manufacturer Label
Device Label
DMX Personality
DMX Personality Description
Device Hours
Tilt Invert
Display Invert

ERROR CODES

When power is applied, the unit will automatically enter a "Reset/Test" mode. This mode brings all the internal motors to a home position. If there is an internal problem with one or more of the motors an error code will flash in the display in the form of "XXer" where as XX will represent a function number. For example, when the display shows "0Er" it means there is some type of error with the Pan motor. If there are multiple errors during the start-up process they will all flash in the display. For example: if the fixtures has errors on Channel 1, 2, and 5 all at the same time, you will see the error message "01Er", "02Er", and "05Er" flash repeated 5 times.

If an error does occur during the initial start-up procedure the fixture will self-generate a second reset signal and try to realign all the motors and correct the errors. If the error persists after a second attempt a third attempt will be made. If after a third attempt all the errors have not been corrected the fixture will make the following determinations:

- 3 or More Errors: The fixture cannot function properly with three or more errors therefore the fixture will place itself in a stand-by mode until subsequent repairs can be made.
- Less Than 3 Errors: The fixture has less than 3 errors; therefore, most other functions will work properly. The fixture will attempt to operate normally until the errors can be correct by a technician. The errors in question will remain flashing in the display as a reminder of internal errors.

Error Codes subject to change without notice	
ERROR CODES	DESCRIPTION
Pan Tilt Cyan Megenta Yellow CTO CTB Color Wheel Gobol Gobol_ROT Gobo2 Gobo2_ROT Fixed_Gobo Focus Zoom Prism1 Prism_Rot1 Prism2 Prism_Rot2 Frost1 Frost2 Iris Animation AnimationRot Blade_Rot LED Temp Error Head Temp Error Base Temp Error 3UHeadFan1 Error 3UHeadFan2 Error 3UHeadFan3 Error 3UHeadFan4 Error 3UHeadFan5 Error 5UHeadFan1 Error 8UHeadFan1 Error 11UHeadFan1 Error 11UHeadFan2 Error 11UHeadFan5 Error 11UHeadFan6 Error Base Fan1 Error Base Fan2 Error Base HD Warning. Base HD Higher. Head HD Warning. Head HD Higher. Base HD Error. Head HD Error.	Movement is not located in the default position after the reset. This message will appear after a fixture reset if the magnetic-indexing circuit malfunctions (sensor failed, or magnet is missing) or there is a motor failure (defective motor or a defective motor IC drive on the main PCB).

SPECIFICATIONS

SOURCE

580W 6,500K Bright White Peak Field LED Engine
30,000 Hour Average LED Life*

*Test lab conditions. May vary depending on several factors including but not limited to:
Environmental Conditions, Power/Voltage, Usage Patterns (On-Off Cycling), Control, and Dimming.

PHOTOMETRIC DATA

33,500 Total Lumen Fixture Output
CRI 71+ (85+ with HCRI Filter)
2.5:1 Hotspot Ratio
Zoom Range 5.5° - 50°
Beam Angle 6° - 36.7°
Field Angle 7.6° - 51.3°

EFFECTS

Motorized Zoom
4 Rotating Full Blackout Framing Blades
+/-45° Framing Indexing
Full 360° Bi-Directional Animation Wheel
4-Facet and Linear Rotating Prisms
2 Variable Frost Filters (Light and Wash)
Internal Color, Framing, Prism, and Frost Macros
Motorized Iris with Variable Pulse Effects
Variable 16-bit Dimming Curve Modes
High Speed Electronic Shutter and Strobe
DMX Controllable LED Refresh Rate
Pan Angle: 540°/630°
Tilt Angle: 250°

COLOR

CMY Color Mixing
Linear CTO Color Correction
5 Dichroic Colors including High CRI Filter

GOBOS

3 Gobo Wheels
6 Rotating Gobos (Wheel #1)
7 Rotating Gobos (Wheel #2)
7 Static Gobos (Wheel #3)

CONTROL / CONNECTIONS

2 DMX Channel Modes (43/68 Ch.)
16-bit Pan, Tilt and Dimming Control
Motorized Focus and Auto-Focus Presets
DMX, RDM, Art-NET, sACN Protocol Support
(6) Button Touch Control Panel
Full Color 180° Reversible LCD Menu Display
Hibernation Mode (Power Save)
IP65 Locking 5pin XLR Connector In/Out
IP65 Locking RJ45 Ethernet Connector In/Out
IP65 Locking Power Connector In
With Wired Digital Communication Network

SIZE / WEIGHT

Length: 18.41 in (468mm)
Width: 14.6 in (370mm)
Height: 26.8 in (682mm)
Center-to-Center Spacing: 24.6 in (626mm)
Weight: 89.9 lbs. (40.8 kg)

ELECTRICAL

AC 100-240V 50/60Hz
Max Power Consumption 1000W
-4°F to 113°F (-20°C to 45°C)
BTU/hr (+/- 10%) 3239.5

INCLUDED ITEMS

Omega Brackets (x2)
IP65 Rated 5pin DMX Cable
IP65 Rated RJ45 DATA Cable (Fixture to Fixture Interconnect Use Only!)
IP65 Rated Twist-Lock Power Cable

APPROVALS / RATINGS

CE | cETLus | IP65



Specifications and documentation subject to change without notice.

DIMENSIONS

*Drawings not to scale. Specifications and improvements in the design of this unit and this manual are subject to change without notice.

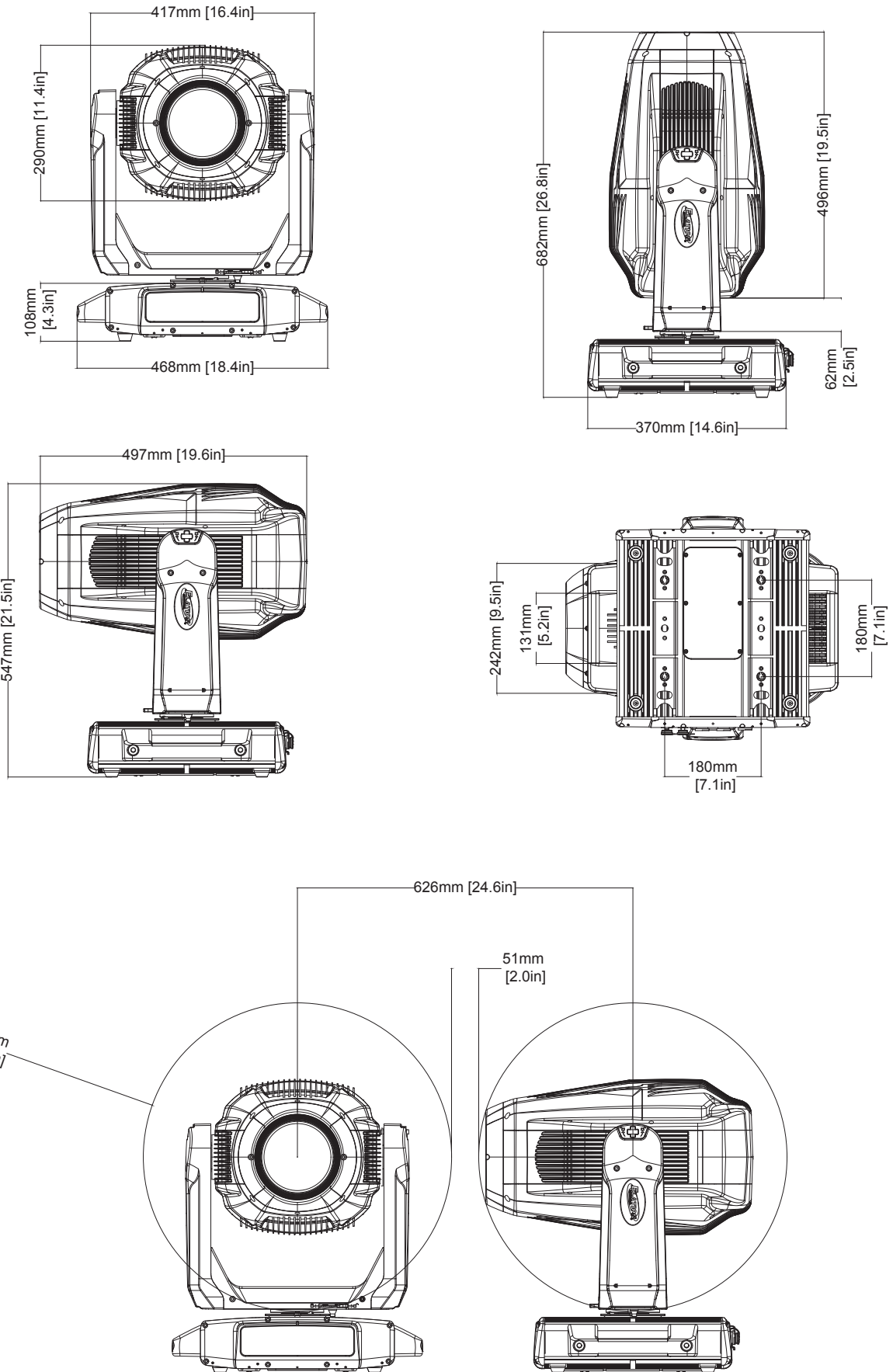

DIMENSIONS

*Drawings not to scale. Specifications and improvements in the design of this unit and this manual are subject to change without notice.

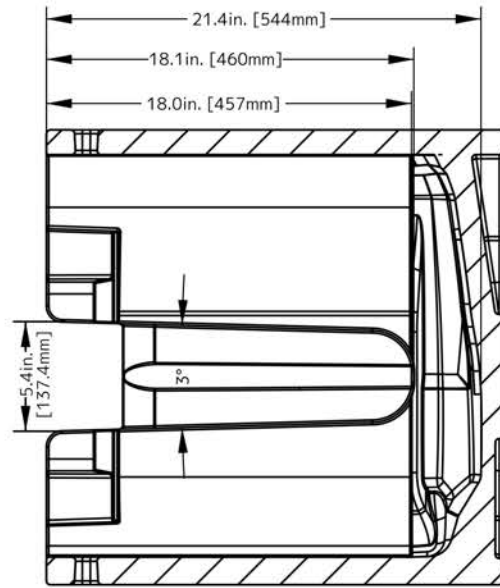
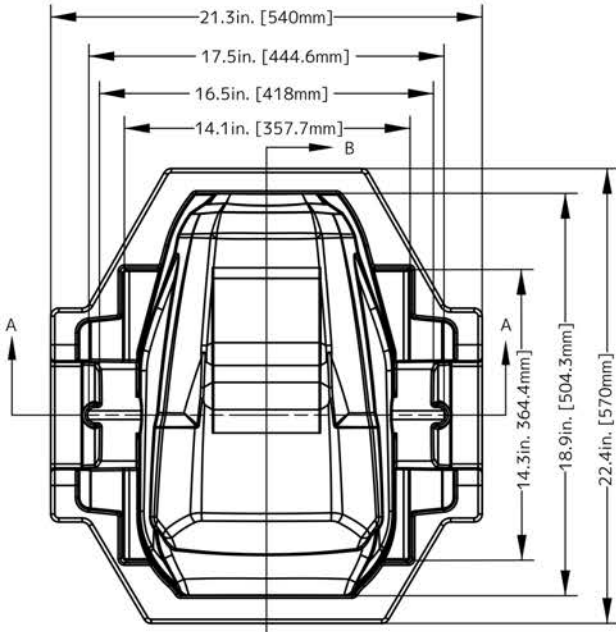

B-B

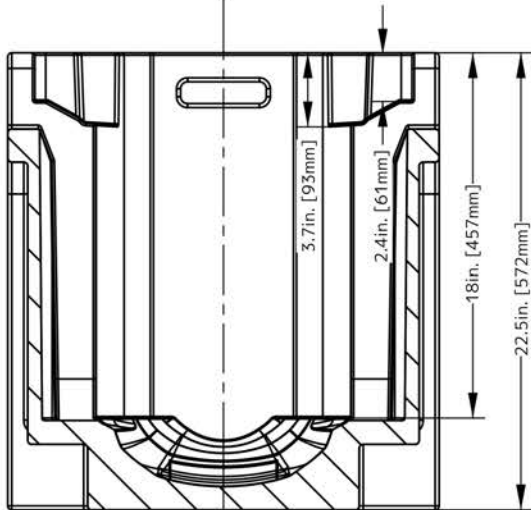

A-A

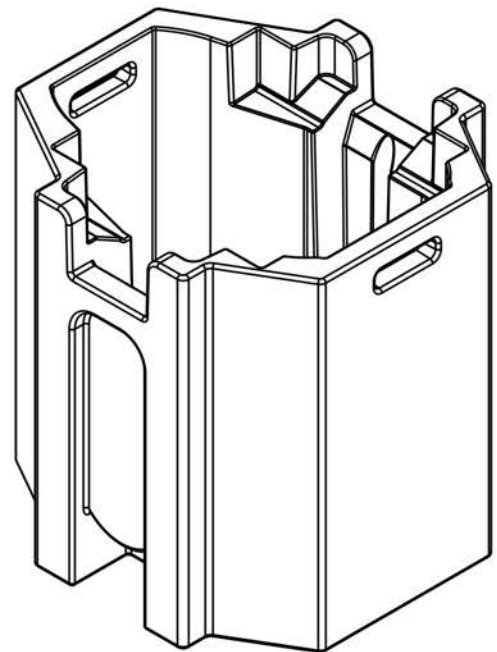
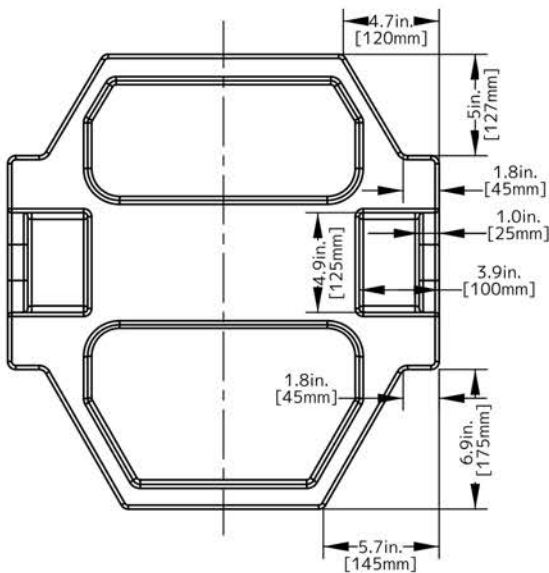

OPTIONAL ACCESSORIES

ORDER CODE (US)	ORDER CODE (EU)	ITEM
PRL546	1237000226	Proteus Lucius
TRIGGER CLAMP	1741000032	Heavy Duty Wrap Around Hook Style Clamp
SIP126	1621000076	5 ft. (1.5m) IP65 Twist Lock Power Link Cable
AC5PDMX5PRO	N/A	5 ft. (1.5m) 5pin PRO DMX Cable
		Additional Cable Lengths Available

FCC STATEMENT

This device complies with Part 15 of the FCC Rules. Operation is subject to the following two conditions: (1) this device may not cause harmful interference, and (2) this device must accept any interference received, including interference that may cause undesired operation.

FCC RADIO FREQUENCY INTERFERENCE WARNINGS & INSTRUCTIONS

This product has been tested and found to comply with the limits as per Part 15 of the FCC Rules. These limits are designed to provide reasonable protection against harmful interference in a residential installation. This device uses and can radiate radio frequency energy and, if not installed and used in accordance with the included instructions, may cause harmful interference to radio communications. However, there is no guarantee that interference will not occur in a particular installation. If this device does cause harmful interference to radio or television reception, which can be determined by turning the device off and on, the user is encouraged to try to correct the interference by one or more of the following methods:

- Reorient or relocate the device.
- Increase the separation between the device and the receiver.
- Connect the device to an electrical outlet on a circuit different from which the radio receiver is connected.
- Consult the dealer or an experienced radio/TV technician for help.

Energy Saving Matters (EuP 2009/125/EC)

Saving electric energy is a key to help protecting the environment. Please turn off all electrical products when they are not in use. To avoid power consumption in idle mode, disconnect all electrical equipment from power when not in use. Thank you!



