

ELATION®

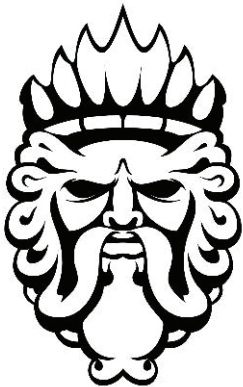

PROTEUS RAYZOR 1960

User Manual

©2023 ELATION PROFESSIONAL all rights reserved. Information, specifications, diagrams, images, and instructions herein are subject to change without notice. ELATION PROFESSIONAL logo and identifying product names and numbers herein are trademarks of ELATION PROFESSIONAL. Copyright protection claimed includes all forms and matters of copyrightable materials and information now allowed by statutory or judicial law or hereinafter granted. Product names used in this document may be trademarks or registered trademarks of their respective companies and are hereby acknowledged. All non-ELATION brands and product names are trademarks or registered trademarks of their respective companies.

ELATION PROFESSIONAL and all affiliated companies hereby disclaim any and all liabilities for property, equipment, building, and electrical damages, injuries to any persons, and direct or indirect economic loss associated with the use or reliance of any information contained within this document, and/or as a result of the improper, unsafe, insufficient and negligent assembly, installation, rigging, and operation of this product.

Elation Professional USA | 6122 S. Eastern Ave. | Los Angeles, CA. 90040
323-582-3322 | 323-832-9142 fax | www.elationlighting.com | info@elationlighting.com

Elation Professional B.V. | Junostraat 2 | 6468 EW Kerkrade, The Netherlands
+31 45 546 85 66 | +31 45 546 85 96 fax | www.elationlighting.eu | info@elationlighting.eu

Elation Professional Mexico
AV Santa Ana 30 | Parque Industrial Lerma, Lerma, Mexico 52000
+52 (728) 282-7070

DOCUMENT VERSION



Due to additional product features and/or enhancements, an updated version of this document may be available online. Please check www.elationlighting.com for the latest revision/update of this manual before beginning installation and/or programming.

Date	Document Version	Software Version	DMX Channels	Notes
09/08/2022	1.0	2.0.0	25 / 100 / 176 ch.	Initial Release
09/21/2022	1.1	N/C	No Change	Updated Installation, Specifications
09/28/2022	1.2	N/C	No Change	Corrected Specifications
11/04/2022	1.3	N/C	No Change	Updated Introduction, Installation Instructions, Torque Settings for Screws, Specifications
01/24/2023	1.4	N/C	No Change	Updated Specifications; Added IP65 Rated
02/06/2023	1.5	N/C	No Change	Updated Introduction
03/30/2023	1.6	N/C	No Change	Updated System Menu
10/31/2023	1.7	N/C	No Change	Updated Introduction, IP65 Rated, Torque Settings for Screws, Specifications; added IP Test Parameters
12/11/2023	1.8	N/C	No Change	Updated Specifications

TABLE OF CONTENTS

Introduction	4
IP65 Rated	6
Warranty Returns	7
Safety Precautions	8
Maintenance Guidelines	10
Overview	12
Installation	13
Torque Settings for Screws	21
IP Test Parameters	22
Remote Device Management (RDM)	24
Control Panel	25
System Menu	26
Record Controller	29
Fan Control and Low Noise Operation	31
Lighting Console Patching Guidelines	32
DMX Traits	37
FX Generator Guidelines	48
RGBW Pixel FX Table	49
Spark LED FX Table	54
Waveforms	58
Dimmer Curves	59
Color Temperature Table	60
Primary-Secondary Set Up	62
Error Codes	63
Software Update	64
Dimensional Drawings	65
Specifications	67
FCC Statement	68

INTRODUCTION

Please read and understand the instructions in this manual carefully and thoroughly before attempting to operate this device. These instructions contain important safety and use information. **This device is intended for use by trained personnel only, and is not suitable for private use.**

UNPACKING

Every device has been thoroughly tested and has been shipped in perfect operating condition. Carefully check the shipping carton for damage that may have occurred during shipping. If the carton is damaged, carefully inspect the device for damage, and be sure all accessories necessary to install and operate the device have arrived intact. In the event that damage has been found or parts are missing, please contact our customer support team for further instructions. Please do not return this device to your dealer without first contacting customer support. Please do not discard the shipping carton in the trash. Please recycle whenever possible.

IP65 RATED

An IP rated lighting fixture is commonly installed in outdoor environments and has been designed with an enclosure that effectively protects the ingress (entry) of external foreign objects such as dust and water. The International Protection (IP) rating system is commonly expressed as "IP" followed by two numbers (i.e. IP65) where the numbers define the degree of protection. The first digit (Foreign Bodies Protection) indicates the extent of protection against particles entering the fixture, while the second digit (Water Protection) indicates the extent of protection against water entering the fixture. **An IP65 rated lighting fixture, such as this one, has been designed and tested to protect against the ingress of dust (6) and low-pressure water jets from any direction (5). This fixture is intended for temporary outdoor use only!**

BOX CONTENTS

Power Cable (x1)

CUSTOMER SUPPORT

Contact ELATION Service for any product related service and support needs. Also visit forums.elationlighting.com with questions, comments or suggestions.

ELATION SERVICE USA - Monday - Friday 8:00am to 4:30pm PST
323-582-3322 | Fax 323-832-9142 | support@elationlighting.com

ELATION SERVICE EUROPE - Monday - Friday 08:30 to 17:00 CET
+31 45 546 85 63 | Fax +31 45 546 85 96 | support@elationlighting.eu

REPLACEMENT PARTS - please visit parts.elationlighting.com

INTRODUCTION

LENS POSITION FOR SHIPPING AND PACKAGING:

When re-packaging this fixture for shipping or transportation, the device must be placed securely into the form-fitting foam in-lay (FIL) that was included in the box when the fixture was first purchased. Please refer to the **Dimensional Drawings** section of this manual for detailed information about the foam in-lay.

Additionally, it is **CRITICALLY IMPORTANT** to orient the head of the fixture so that the lens is pointing toward the base of the unit, as illustrated below. **Failure to do so can result in damage to the fixture's zoom function while in transit.** Reminder notices will be stamped into the foam in-lay itself as a precautionary measure.



IP65 RATED

The International Protection (IP) rating system is commonly expressed as “IP” (Ingress Protection) followed by two numbers (i.e. IP65), where the numbers define the degree of protection. The first digit (Foreign Bodies Protection) indicates the extent of protection against particles entering the fixture, and the second digit (Water Protection) indicates the extent of protection against water entering the fixture. An **IP65** rated lighting fixture is designed and tested to protect against the ingress of dust (**6**), and low-pressure water jets from any direction (**5**).

Maritime/Coastal Environment Installations: A coastal environment is seaside adjacent, and caustic to electronics through exposure to atomized salt-water and humidity, whereas maritime is anywhere within 5-miles of a coastal environment.

Maritime installations require additional preparation, and additional service intervals may be needed given the maritime use. In general, IP ratings presuppose freshwater conditions VS maritime conditions, which are typically more “caustic” to IP fixtures (both internally and externally). A duty-cycle may also be needed when units are not in use. During times of high humidity and colder temperatures, condensation may occur internally so the fixture may require a duty-cycle to bring it up to running temperature, allowing any accumulation of moisture to be expelled via the vent valve. Recommendations can change based on installation environmental circumstances.

NOTE: NOT ALL FEATURES LISTED ARE AVAILABLE ON ALL FIXTURES; THE FOLLOWING INSTRUCTIONS MAY NOT APPLY. CONTACT SUPPORT FOR ADDITIONAL DETAILS.

Exterior Maintenance: Inspect the exterior every 30-days. The unit must be powered off/disconnected. The chassis should be inspected for any signs of contaminants. Inspect optics to determine if the lens is obstructed, then clean optics and chassis accordingly. Based on initial finding, schedule maintenance accordingly, keeping in mind that exterior maintenance will be required. Even if the luminaires are NOT in use, maintenance will still be needed given its location (exterior use). The use of a durable type of wax on the chassis is recommended since it will help prevent contaminant build up. Inspect both power and data lines for any signs of contaminants or corrosion. Periodically reapplying di-electric grease, especially in coastal environments. If any signs of corrosion/contaminants are present, clean thoroughly, and/or replace connectors, then reapply di-electric grease. Typically, this should be done annually, or any time an opportunity presents itself. As a preventive measure, annual replacement of both vent valves is recommended. The vent valve membrane can become contaminated and/or clogged causing improper venting of humidity within the luminaire. Inspect all mounting hardware as a precaution.

Interior Maintenance: Inspect the interior every 30-days. The unit must be powered off/disconnected.

- Inspect zoom/focus mechanism, clean optics, lubricate linear bearings (Krytox oil) as needed, inspect belts for wear
- Inspect all rotating effect wheels, manually rotate them, note any resistance
- Inspect all remaining rotating belts for any wear
- Inspect all fans, clean as needed, check rotation, check connections
- Inspect CMY module, manually move flags and check for signs of resistance, and if needed, clean guide rods first, then reapply a thin layer of grease (moly lube)
- Clean interior with low-volume compressed air, then clean optics prior to reassembly of head covers

Although the base has limited moving parts, the pan belt should also be inspected for wear. Remember to always perform an IP test anytime a cover is removed.

There is no specific time frame regarding the routine replacement of parts such as belts/stepper motors, PCBs, or LEDs. These items should only be replaced on an as needed bases, except for cooling fans, which should be replaced once the luminaries reach 10,000-hours. This is a prophylactic measure intended to keep the unit running as cool as possible, insuring proper function of all internal components. A complete service breakdown is available, please contact service@elationlighting.com for any needed parts or manuals.

LIMITED WARRANTY (USA ONLY)

- A. Elation Professional hereby warrants, to the original purchaser, Elation Professional products to be free of manufacturing defects in material and workmanship for a period of two years (730 days), and Elation Professional product rechargeable batteries to be free of manufacturing defects in material and workmanship for a period of six months (180 days), from the original date of purchase. This warranty excludes discharge lamps and all product accessories. This warranty shall be valid only if the product is purchased within the United States of America, including possessions and territories. It is the owner's responsibility to establish the date and place of purchase by acceptable evidence, at the time service is sought.
- B. For warranty service, send the product only to the Elation Professional factory. All shipping charges must be pre-paid. If the requested repairs or service (including parts replacement) are within the terms of this warranty, Elation Professional will pay return shipping charges only to a designated point within the United States. If any product is sent, it must be shipped in its original package and packaging material. No accessories should be shipped with the product. If any accessories are shipped with the product, Elation Professional shall have no liability what so ever for loss and/or or damage to any such accessories, nor for the safe return thereof.
- C. This warranty is void if the product serial number and/or labels are altered or removed; if the product is modified in any manner which Elation Professional concludes, after inspection, affects the reliability of the product; if the product has been repaired or serviced by anyone other than the Elation Professional factory unless prior written authorization was issued to purchaser by Elation Professional; if the product is damaged because not properly maintained as set forth in the product instructions, guidelines and/or user manual.
- D. This is not a service contract, and this warranty does not include any maintenance, cleaning or periodic check-up. During the periods as specified above, Elation Professional will replace defective parts at its expense, and will absorb all expenses for warranty service and repair labor by reason of defects in material or workmanship. The sole responsibility of Elation Professional under this warranty shall be limited to the repair of the product, or replacement thereof, including parts, at the sole discretion of Elation Professional. All products covered by this warranty were manufactured after January 1, 1990, and bare identifying marks to that effect.
- E. Elation Professional reserves the right to make changes in design and/or performance improvements upon its products without any obligation to include these changes in any products theretofore manufactured.
- F. No warranty, whether expressed or implied, is given or made with respect to any accessory supplied with the products described above. Except to the extent prohibited by applicable law, all implied warranties made by Elation Professional in connection with this product, including warranties of merchantability or fitness, are limited in duration to the warranty periods set forth above. And no warranties, whether expressed or implied, including warranties of merchantability or fitness, shall apply to this product after said periods have expired. The consumer's and/or dealer's sole remedy shall be such repair or replacement as is expressly provided above; and under no circumstances shall Elation Professional be liable for any loss and/or damage, direct and/or consequential, arising out of the use of, and/or the inability to use, this product.
- G. This warranty is the only written warranty applicable to Elation Professional products and supersedes all prior warranties and written descriptions of warranty terms and conditions heretofore published.

WARRANTY RETURNS

All returned service items whether under warranty or not, must be freight pre-paid and accompanied by a return authorization (R.A.) number. The R.A. number must be clearly written on the outside of the return package. A brief description of the problem, as well as the R.A. number, must also be written down on a piece of paper and included in the shipping container. If the unit is under warranty, you must provide a copy of your proof of purchase invoice. Items returned without an R.A. number clearly marked on the out-side of the package will be refused and returned at customer's expense. You may obtain an R.A. number by contacting customer support.

SAFETY PRECAUTIONS

This fixture is a sophisticated piece of electronic equipment. To guarantee a smooth operation, it is important to follow all instructions and guidelines in this manual. Elation Professional is not responsible for injuries and/or damages resulting from the misuse of this fixture due to the disregard of the information printed in this manual. Only qualified and/or certified personnel should perform installation of this fixture and only the original rigging parts included with this fixture should be used for installation. Any modifications to the fixture and/or the included mounting hardware will void the original manufacturer's warranty and increase the risk of damage and/or personal injury



PROTECTION CLASS 1 - FIXTURE MUST BE PROPERLY GROUNDED.



THERE ARE NO USER SERVICEABLE PARTS INSIDE THIS UNIT. DO NOT ATTEMPT ANY REPAIRS YOURSELF, AS DOING SO WILL VOID YOUR MANUFACTURER'S WARRANTY. DAMAGES RESULTING FROM MODIFICATIONS TO THIS FIXTURE AND/OR THE DISREGARD OF SAFETY INSTRUCTIONS AND GUIDELINES IN THIS MANUAL VOID THE MANUFACTURER'S WARRANTY AND ARE NOT SUBJECT TO ANY WARRANTY CLAIMS AND/OR REPAIRS.



**DO NOT PLUG FIXTURE INTO A DIMMER PACK!
NEVER OPEN THIS FIXTURE WHILE IN USE!
UNPLUG POWER BEFORE SERVICING FIXTURE!
NEVER TOUCH FIXTURE DURING OPERATION, AS IT MAY BE HOT! KEEP FLAMMABLE MATERIALS AWAY FROM FIXTURE!**



**NEVER LOOK DIRECTLY INTO THE LIGHT SOURCE!
RETINA INJURY RISK - MAY INDUCE BLINDNESS!
SENSITIVE PERSONS MAY SUFFER AN EPILEPTIC SHOCK!**



ENSURE ALL CONNECTIONS AND END CAPS ARE PROPERLY SEALED WITH A DIELECTRIC GREASE (AVAILABLE AT MOST ELECTRICAL SUPPLIERS) TO PREVENT WATER CORROSION AND/OR ELECTRICAL SHORT CIRCUIT.



**MINIMUM DISTANCE TO OBJECTS/SURFACES
MUST BE 3.3 FEET (1 METER)
MAXIMUM TEMP OF EXTERNAL SURFACE 185° F (85°C)
MINIMUM DISTANCE OF FLAMMABLE MATERIALS FROM THE SURFACE 1.6 FEET
(0.5 METER)**

SAFETY PRECAUTIONS

- DO NOT TOUCH the fixture housing during operation. Turn OFF the power and allow approximately 15 minutes for the fixture to cool down before servicing.
- DO NOT shake fixture, and avoid using brute force when installing and/or operating the fixture.
- DO NOT operate the fixture if the power cord is frayed, crimped, damaged, and/or if any of the power cord connectors are damaged and do not plug into the fixture securely with ease.
- NEVER force a power cord connector into the fixture. If the power cord or any of its connectors are damaged, replace it immediately with a new one of the same power rating.
- DO NOT block any air ventilation slots.
- All fan and air inlets must remain clean and never blocked.
- Leave approx. 6" (15cm) between the fixture and other devices or a wall in order to allow for proper cooling.
- Always disconnect the fixture from the main power source before performing any type of service and/or cleaning procedure.
- Only handle the power cord by the plug end. Never pull out the plug by tugging on the wire portion of the cord.
- During the initial operation of this fixture, a light smoke or smell may emit from the interior of the fixture. This is a normal process and is caused by excess paint in the interior of the casing burning off from the heat associated with the lamp. This will decrease gradually over time.
- Consistent operational breaks will ensure fixture will function properly for many years.
- ONLY use the original packaging and materials to transport the fixture for service.

MAINTENANCE GUIDELINES



DISCONNECT POWER BEFORE PERFORMING ANY MAINTENANCE!

CLEANING

Frequent cleaning is recommended to ensure proper function, optimized light output, and an extended life. The frequency of cleaning depends on the environment in which the fixture operates: damp, smoky or particularly dirty environments can cause greater accumulation of dirt on the fixture's optics. Periodically clean the external lens surface with a soft cloth to avoid dirt/debris accumulation. **NEVER** use alcohol, solvents, or ammonia-based cleaners.

MAINTENANCE

Regular inspections are recommended to insure proper function and extended life. There are no user serviceable parts inside this fixture. Please refer all other service issues to an authorized Elation service technician. Should you need any spare parts, please order genuine parts from your local Elation dealer.

Please refer to the following points during routine inspections:

- A detailed electric check by an approved electrical engineer every three months, to make sure the circuit contacts are in good condition and prevent overheating.
- Be sure all screws and fasteners are securely tightened at all times. Loose screws may fall out during normal operation, resulting in damage or injury as larger parts could fall.
- Check for any deformations on the housing, color lenses, rigging hardware, and rigging points (ceiling, suspension, trussing). Deformations in the housing could allow for dust to enter into the fixture. Damaged rigging points or unsecured rigging could cause the fixture to fall and seriously injure a person(s).
- Electric power supply cables must not show any damage, material fatigue or sediments. **NEVER** remove the ground prong from the power cable.

FIXTURE DISASSEMBLY

The following points should be observed after performing any maintenance procedure that requires disassembly of the unit:

- After the unit has been reassembled, open the valve and allow the unit to run for approximately 2 hours in order to dry out any moisture that has been trapped inside the fixture. The process should continue until indicated humidity drops below 15% for the head and 30% for the base.
- Once this has been achieved, the light can be switched off, but the unit should remain connected to power so that the cooling fan can cool down the unit. Please note that allowing cool down time should **ALWAYS** be done after lamp operation.
- Some units may require partial disassembly in order to gain access to the valve. Please contact Elation service for information regarding the location and access procedure for the valve on your specific unit model.

MAINTENANCE GUIDELINES

BATTERY REPLACEMENT



Installing the battery in the incorrect orientation will lead to internal electronics and battery damage. A qualified electrician should be used for all electrical connections and/or installations.

Follow the directions below to replace the battery:

1. Loosen the screw cap for the battery compartment, as shown below to the left.
2. Remove old battery and replace. **Make sure the battery is oriented with the negative "-" terminal towards the inside and the positive "+" terminal towards the outside.** Refer to the illustration below to the right.
3. Replace and tighten screw cap to secure the battery in place.

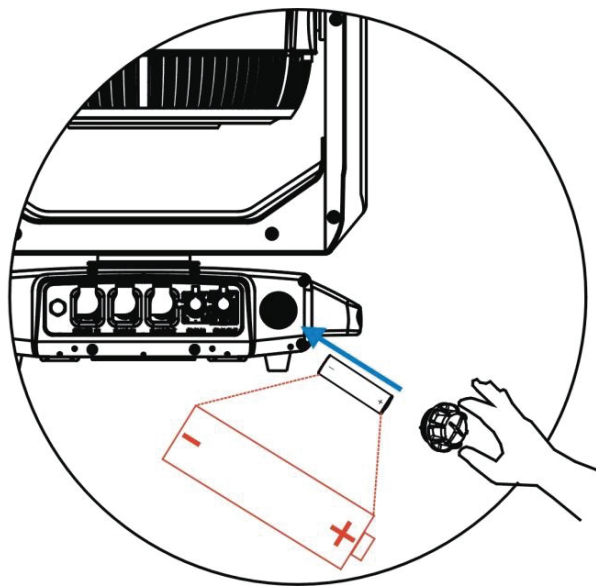
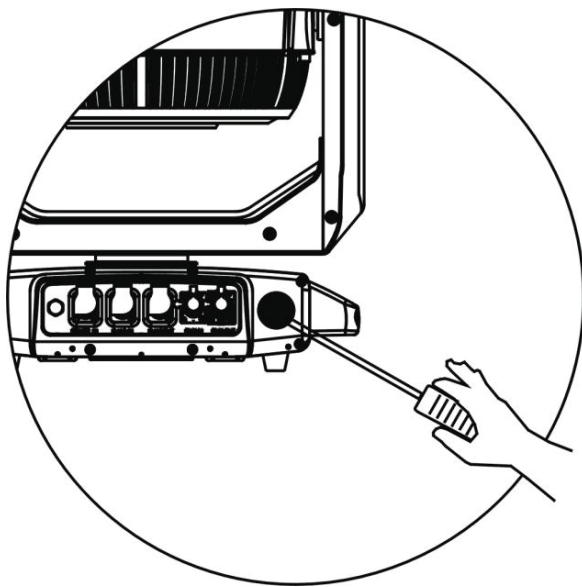

NOTE: Replace the battery only with an Li-ion battery (IRC14500/700mAh), which can be ordered from the Elation Parts Website.

<https://parts.elationlighting.com/catalog/product/view/id/18373/s/60420050026/category/2/>

OVERVIEW

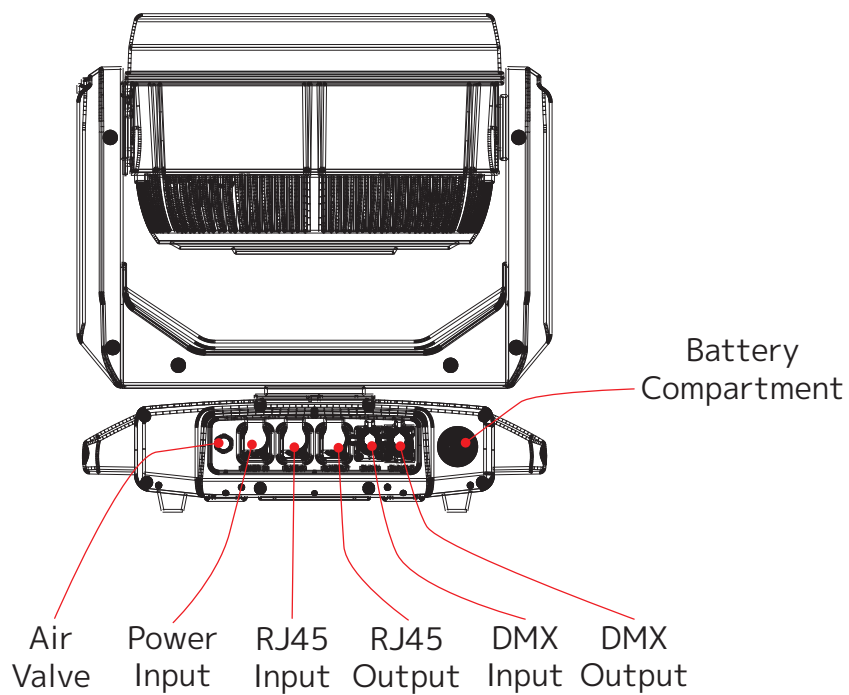
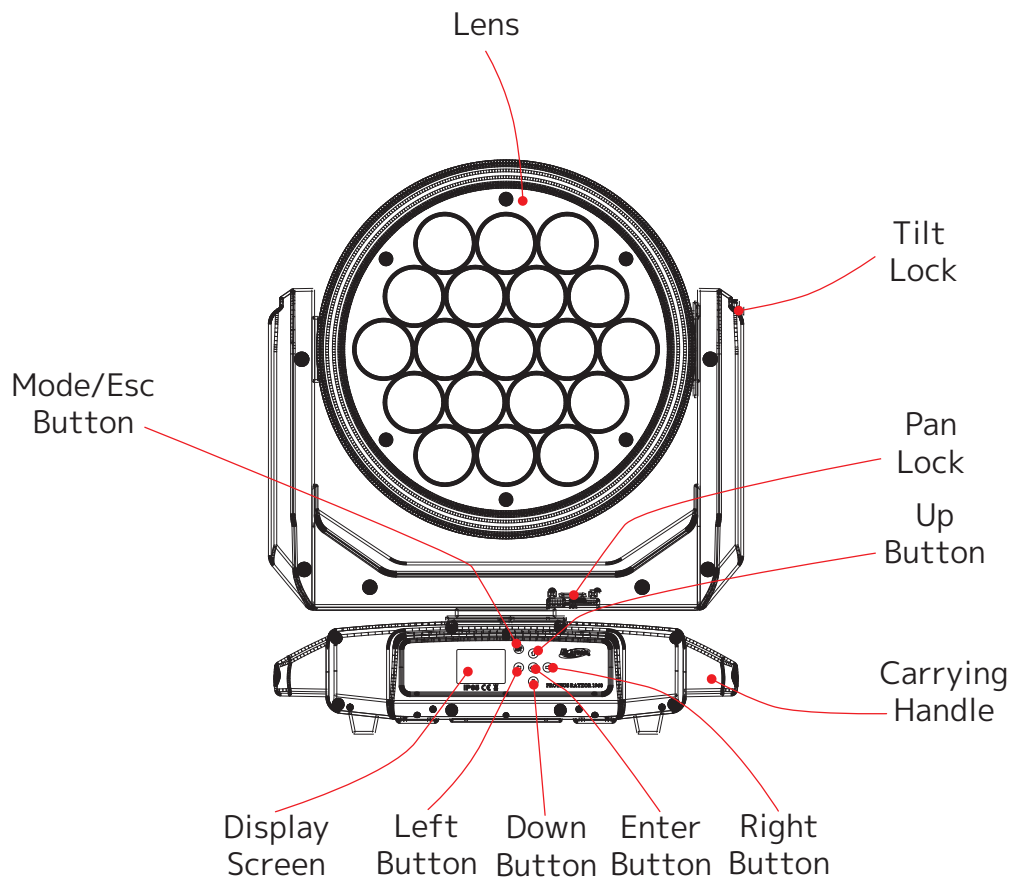

INSTALLATION



FLAMMABLE MATERIAL WARNING

Keep fixture minimum 3.3 feet (1.0m) away from flammable materials and/or pyrotechnics.



ELECTRICAL CONNECTIONS

A qualified electrician should be used for all electrical connections and/or installations.



MINIMUM DISTANCE TO SURFACES/OBJECTS IS 3.3 FEET (1 METER).

MINIMUM DISTANCE TO FLAMMABLE MATERIALS IS 1.6 FEET (0.5 METER).

EXTERNAL SURFACE CAN REACH TEMPERATURES OF 185° F (85° C).



DO NOT INSTALL THE FIXTURE IF YOU ARE NOT QUALIFIED TO DO SO!

Fixture **MUST** be installed following all local, national, and country commercial electrical and construction codes and regulations.

Before rigging/mounting a single fixture or multiple fixtures to any metal truss/structure or placing the fixture(s) on any surface, a professional equipment installer **MUST** be consulted to determine if the metal truss/structure or surface is properly certified to safely hold the combined weight of the fixture(s), clamps, cables, and accessories.

Overhead rigging requires extensive experience, including calculating working load limits, installation material being used, and periodic safety inspection of all installation material and the fixture, among other skills. If you lack these qualifications, do not attempt the installation yourself. Improper installation can result in bodily injury.

Fixture ambient operating temperature range is **-4° to 113°F (-20° to 45°C)**. Do not operate the fixture when the ambient temperature falls outside of this range.

Fixture(s) should be installed away from walking paths, seating areas, or areas where unauthorized personnel might reach the fixture by hand.

NEVER stand directly below the fixture(s) when rigging, removing, or servicing.

Overhead fixture installation must always be secured with a secondary safety attachment, such as an appropriately rated safety cable.

Allow approximately 15 minutes for the fixture to cool down before serving.

INSTALLATION GUIDELINES

OMEGA BRACKET INSTALLATION

When mounting the fixture to a truss using Omega brackets, first attach a mounting clamp to each Omega bracket using an M10 screw inserted through the center hole of each Omega bracket (see top illustration). Then, insert the Omega Brackets into the outer mounting holes on the underside of the fixture (see lower illustration). Secure the Omega Brackets to the fixture by turning each quick-lock fastener $\frac{1}{4}$ turn clockwise. **Always check to make sure that each fastener is completely locked.**

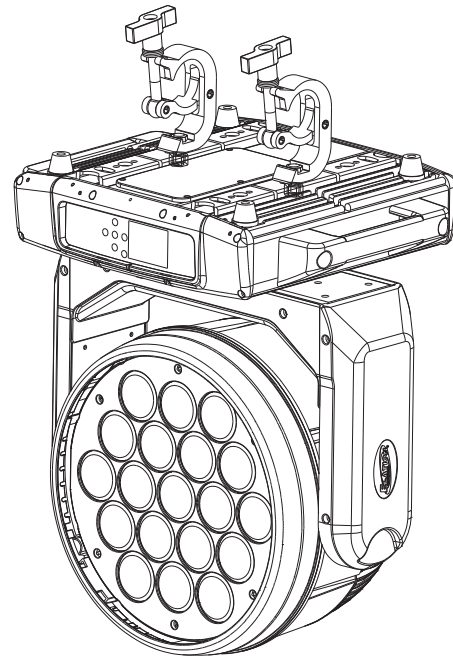
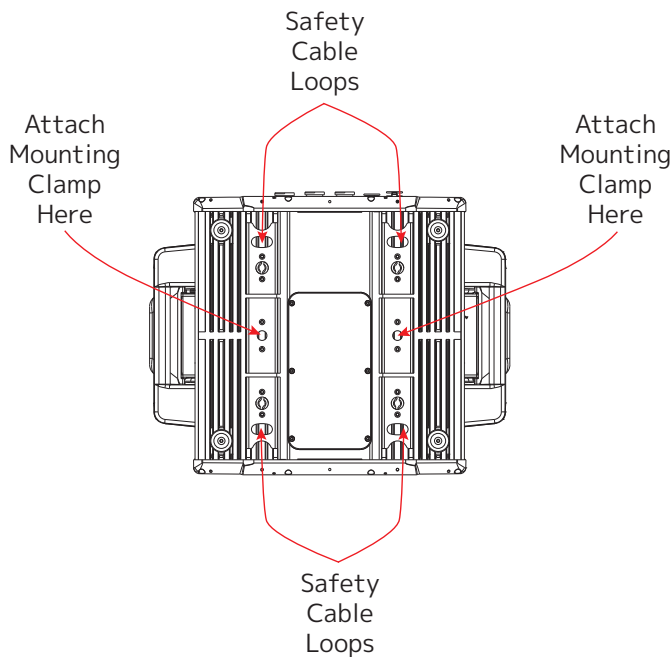
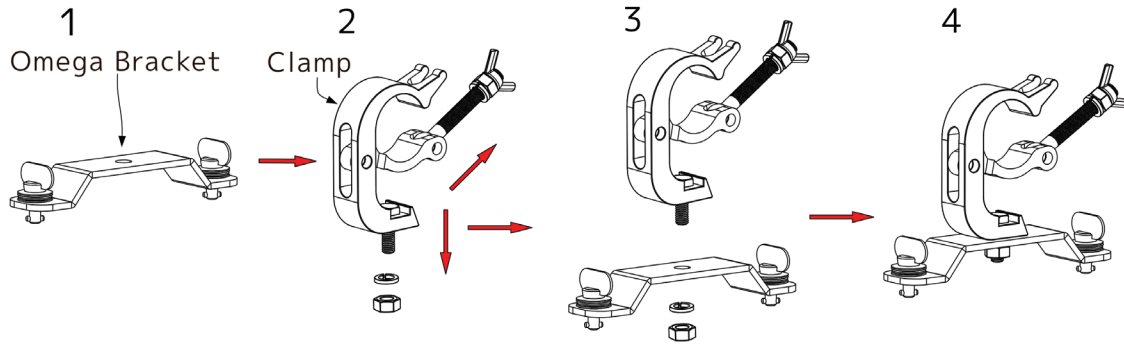

SAFETY CABLE:

ALWAYS ATTACH A SAFETY CABLE WHENEVER INSTALLING THIS FIXTURE IN A SUSPENDED ENVIRONMENT TO ENSURE THAT THE FIXTURE WILL NOT FALL IF THE CLAMP FAILS. ONLY USE DESIGNATED RIGGING POINTS FOR SAFETY CABLE, AND NEVER ATTACH A SAFELY CABLE TO A CARRYING HANDLE.



INSTALLATION GUIDELINES

CLAMP INSTALLATION

Alternately, the fixture can be mounted to a truss using mounting clamps secured directly to the fixture itself. Insert one minimum grade 8.8 steel M12x25mm bolts (not included) into the mounting hole of each mounting clamp. **Please note that TWO (2) MOUNTING CLAMPS are required to support the fixture safely and securely.** Thread each bolt into the matching 12M holes on the underside of the fixture, as shown in the illustration below. Both bolt must be threaded to a depth of at least 18mm (0.7in) into the fixture base.

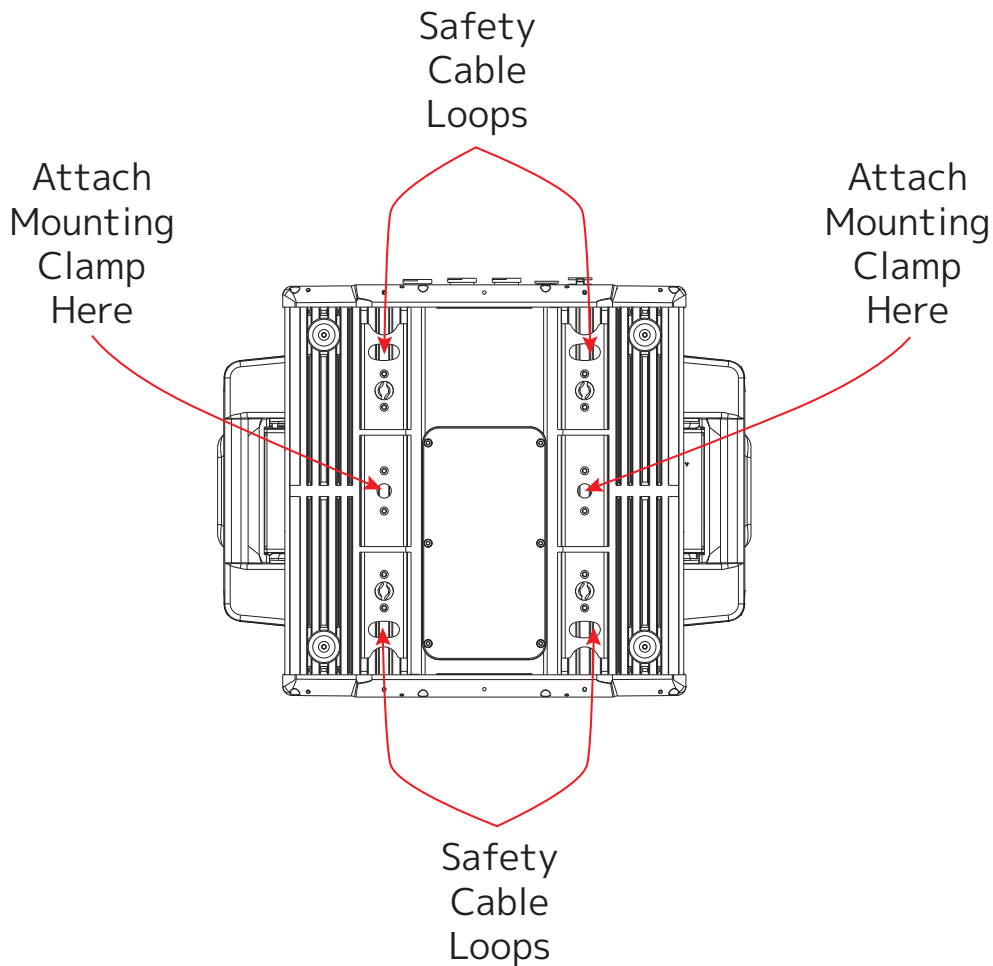

SAFETY CABLE:
ALWAYS ATTACH A SAFETY CABLE WHENEVER INSTALLING THIS FIXTURE IN A SUSPENDED ENVIRONMENT TO ENSURE THAT THE FIXTURE WILL NOT FALL IF THE CLAMP FAILS. ONLY USE DESIGNATED RIGGING POINTS FOR SAFETY CABLE, AND NEVER ATTACH A SAFELY CABLE TO A CARRYING HANDLE.

INSTALLATION GUIDELINES

RIGGING

Overhead rigging requires extensive experience, including calculating working load limits, installation material being used, and periodic safety inspection of all installation material and the fixture, among other skills. If you lack these qualifications, do not attempt the installation yourself. Improper installation can result in bodily injury.

The fixture is fully operational in the following positions: hanging from a horizontal truss, suspended sideways from a vertical truss, or standing upright on a flat, level surface. See the illustration below for reference.

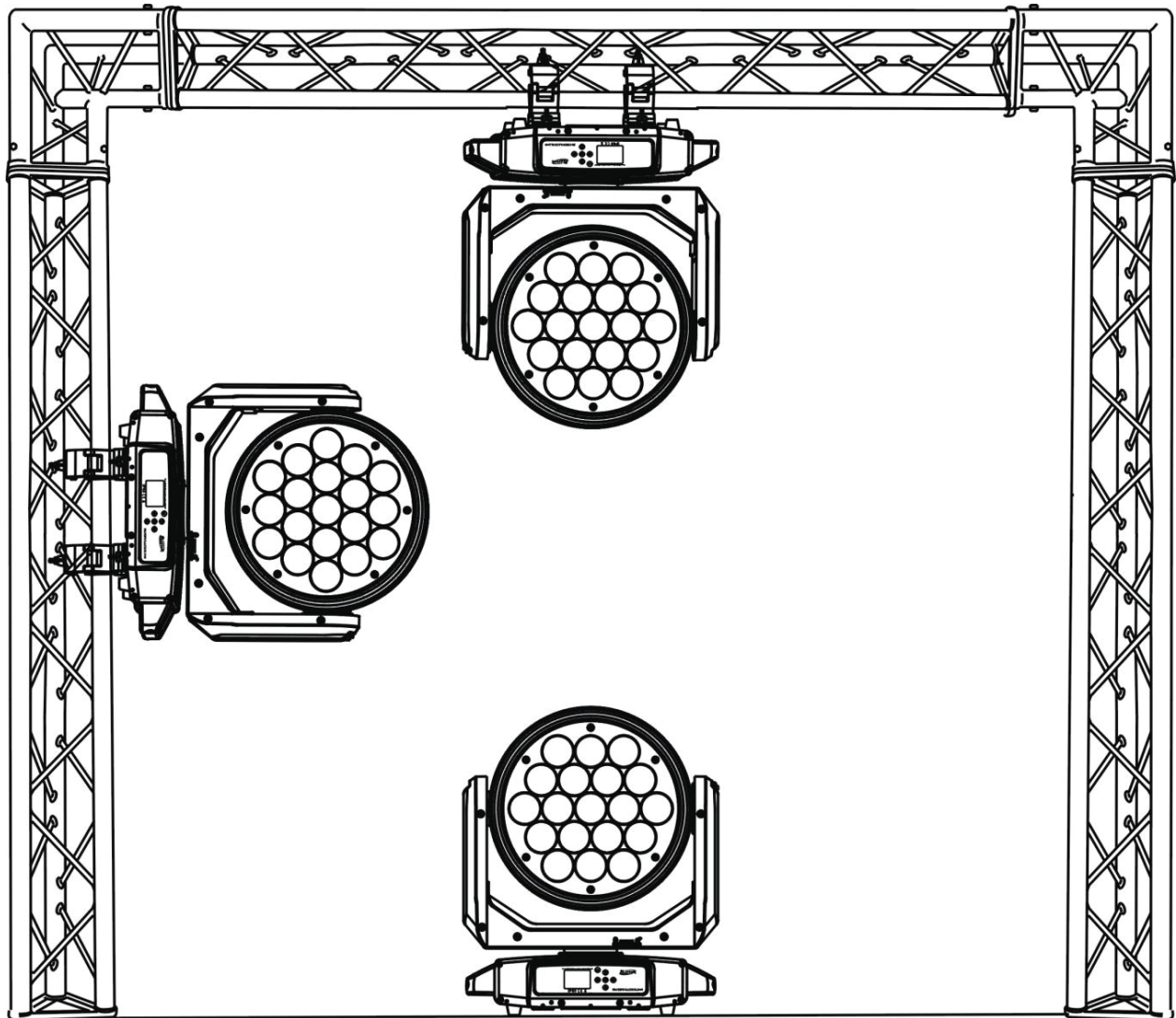

INSTALLATION GUIDELINES

ART-NET AND sACN CONNECTION

When connecting the fixture to a network switch to control multiple devices, a Gigabit Ethernet Switch that supports IGMP (Internet Group Management Protocol) is required. Using a Gigabit Ethernet Switch that does not support IGMP can cause erratic behavior of all connected devices to the switch. Visit the link below for more information about IGMP.

https://en.wikipedia.org/wiki/Internet_Group_Management_Protocol

POWER AND DATA CABLES



TO MAINTAIN THE IP65 RATING INTEGRITY OF THE FIXTURE, ALL CABLES MUST BE RUN TOWARDS THE GROUND IN ORDER TO PREVENT WATER ACCUMULATION AROUND THE CONNECTIONS.

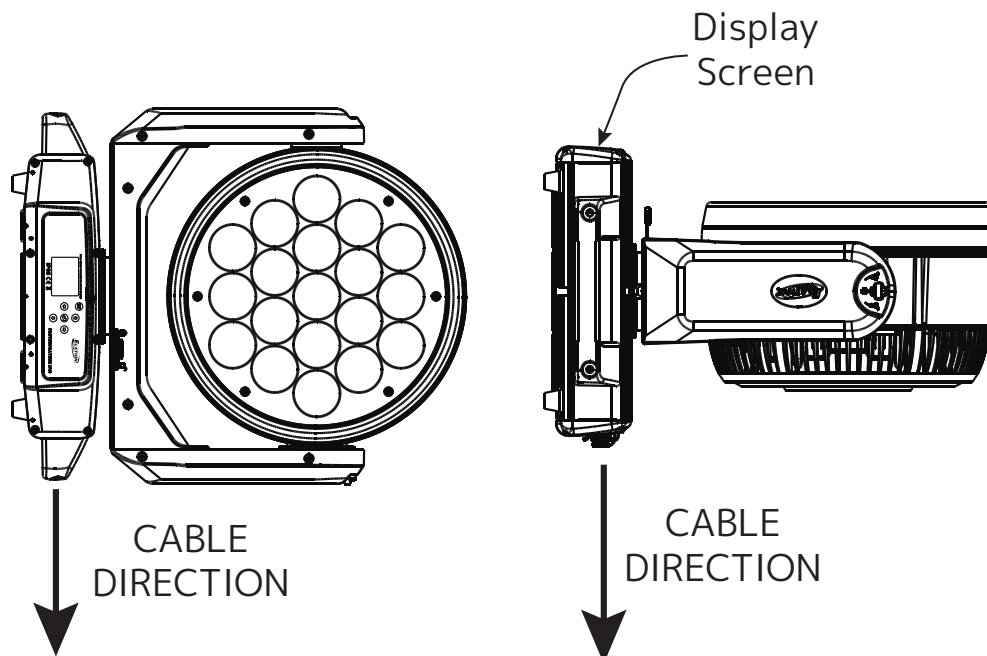

RJ45 DATA CABLES



THE INCLUDED RJ45 DATA CABLE IS FOR FIXTURE TO FIXTURE INTERCONNECTIONS ONLY! THE RJ45 CABLE CONNECTORS MAY NOT BE COMPATIBLE WITH OTHER RJ45 OR ETHERNET TYPE CONNECTORS.

POWER AND DATA CONNECTIONS



ENSURE ALL CONNECTIONS AND END CAPS ARE PROPERLY SEALED WITH A DIELECTRIC GREASE (AVAILABLE AT MOST ELECTRICAL SUPPLIERS) IN ORDER TO PREVENT WATER CORROSION AND/OR ELECTRICAL SHORT CIRCUIT.



TO MAINTAIN IP65 RATING INTEGRITY AND PREVENT WATER FROM ENTERING THE FIXTURE, SEAL ALL UNUSED CONNECTION RUBBER CAPS.

INSTALLATION

POTENTIAL INTERNAL FIXTURE DAMAGE FROM EXTERNAL SOURCES OF LIGHT BEAMS

External sources of light beams from direct sunlight, lighting and moving head fixtures, and lasers, which are focused directly towards the exterior housing and/or penetrate the front lens opening of Elation lighting fixtures, can cause severe internal damage including burning of optics, dichroic color filters, glass and metal gobos, prisms, animation wheels, frost filters, iris, shutters, motors, belts, wiring, discharge lamps, and LEDs.

This issue is not specific only to Elation lighting fixtures, but rather it is a common issue with lighting fixtures from all manufacturers. Although there is no true way to fully prevent this issue from happening, the guidelines below can reduce the risk of potential damage. Contact Elation Service for more details.

DO NOT EXPOSE THE FIXTURE AND/OR FRONT LENS OPENING TO LIGHT BEAMS FROM DIRECT SUNLIGHT, OTHER LIGHTING OR MOVING HEAD FIXTURES, AND LASERS DURING UNPACKING, INSTALLATION, USE, AND EXTENDED IDLE TIMES OUTDOORS. DO NOT FOCUS A LIGHT BEAM FROM ONE LIGHTING FIXTURE DIRECTLY TOWARDS ANOTHER.

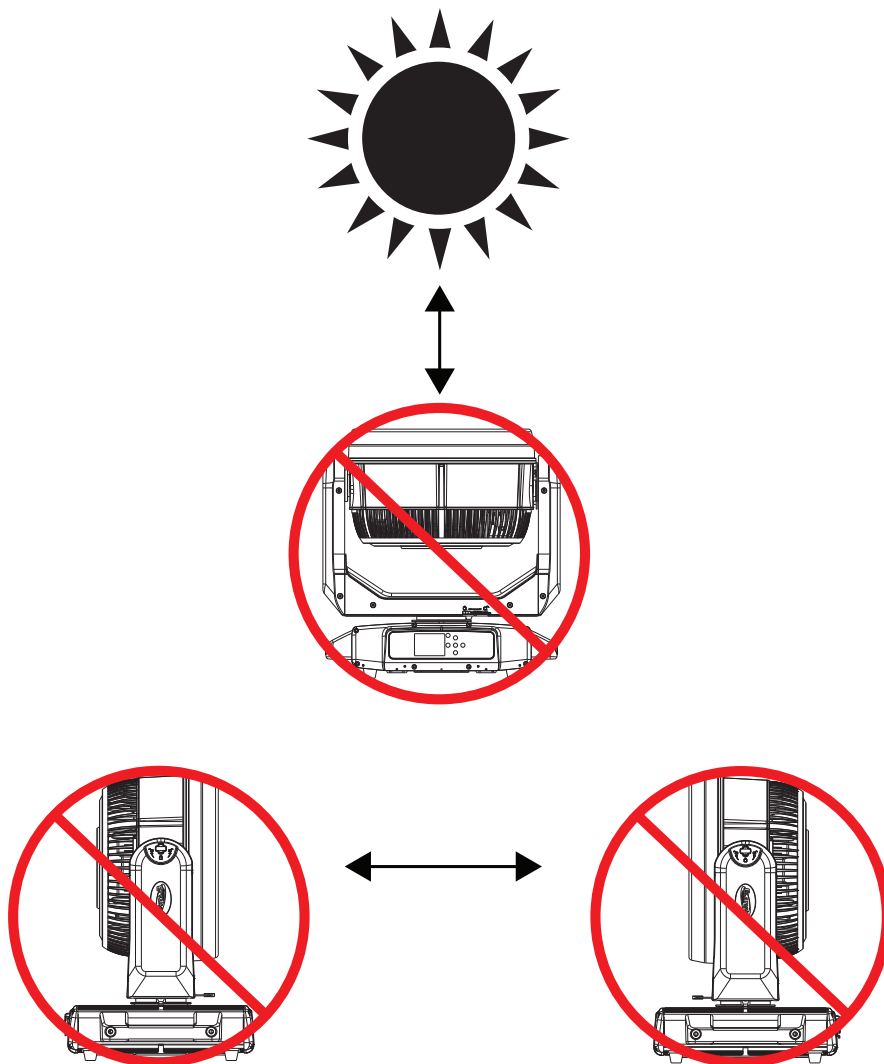

INSTALLATION

SUN PROTECTION MODE

This fixture incorporates an automatic protection from harmful sun rays, which can damage the fixture’s internal components as a result of extended exposure. The fixture uses an internal sensor to determine physical orientation, then point the fixture towards the ground to prevent sunlight from entering the lens.

Please note that this feature only works when the fixture is powered on. When performing installation or maintenance with the fixture powered off, it is important to always move the lenses out of direct sunlight and/or point them manually to the ground. **Even a few minutes of sunlight exposure can cause damage to components inside the fixture.**

The Sun Protection setting is part of the “No DMX Status” menu, and can be accessed by navigating to PERSONALITY > STATUS SETTINGS > NO DMX STATUS > SUN PROTECTION. A quick reference is provided in the table below. Refer to the **System Menu** section of this manual for detailed information.

MAIN MENU	SUB MENU	OPTIONS	
Personality	Status Settings	No DMX Status	Sun Protection (default)
			Close
			Hold
			Auto Program

The sun protection position is activated under the following conditions:

- **Power on without DMX signal:** The fixture always starts in sun protection mode.
- **No DMX Status set to “Sun Protection” option:** The fixture enters sun protection mode after approximately 3 minutes.
- **Remote DMX control:** The sun protection position can be temporarily activated from the lighting console without the need to create a custom position preset. The ability to correctly orient the lens towards the ground is built into the fixture. Note that this also means some fixtures hanging straight down may not move their heads. Hold “Sun Protect Position” for 3s to set the fixture to the sun protection position.

The display screen should display the phrase “Sun Protection: Active” to confirm that this feature has been activated.

The sun protection position is deactivated under the following conditions:

- **DMX signal is connected.**
- **Remote DMX control:** Hold “Sun Protection Off” for 3s.

The sun protection position always uses a 5 second fade time when it is activated or deactivated to avoid harsh movements of the fixture.

INSTALLATION

HIBERNATION MODE

This mode disables motors and most electronics in order to reduce wear on the fixture's internal components. The user has the ability to define the period of time that the fixture can remain inactive before it enters hibernation mode. This feature can be accessed by navigating in the main menu to PERSONALITY > STATUS SETTINGS > HIBERNATION (see the **System Menu** section of this manual for detailed information). The default setting for hibernation delay time is 15 minutes, but it can be adjusted from 1 min to 99 min, or switched off completely.

Hibernation mode is activated under the following conditions:

- **Loss of DMX signal:** the fixture enters hibernation after the timeout expires. Default is 15 minutes.
- **Remote DMX control:** Press and hold "Hibernate Fixture" for 3s.

Hibernation mode is deactivated under the following conditions:

- **DMX signal is connected.**
- **Remote DMX control:** Hold "Hibernate Off" for 3s.

The fixture will perform a full calibration cycle, then assume the current DMX status.

Please note that the Hibernation does not change the PT position of the fixtures. This allows the user to set the desired position and then issue the Hibernate command.

To ensure the fixture is protected from harmful sunrays, it is recommended to either leave the "No DMX Status" in "Sun Protection" mode (so that the fixture is already in the correct position after 3 minutes of DMX loss) or set the fixture to a safe Pan Tilt position manually prior to putting the fixture in hibernation mode.

Burn and heat damage to the fixture's interior components due to external light sources (sun or other fixtures shining into the lens) is never covered under the manufacturer's warranty.

TORQUE SETTINGS FOR SCREWS



PANEL SCREWS MUST BE TIGHTENED WITH A TORQUE WRENCH. REFER TO THE TABLE AND DIAGRAM BELOW FOR PROPER TORQUE SETTINGS.



CAUTION! DO NOT OVER TORQUE SCREWS AS THIS CAN CAUSE LEAKAGE ISSUES! TO CONFIRM THE IP65 INTEGRITY, TEST THE FIXTURE USING THE IP TESTER FOLLOWING ANY INSTANCE IN WHICH THE FIXTURE CASE IS OPENED OR REMOVED. CONTACT ELATION SERVICE FOR MORE DETAILS.

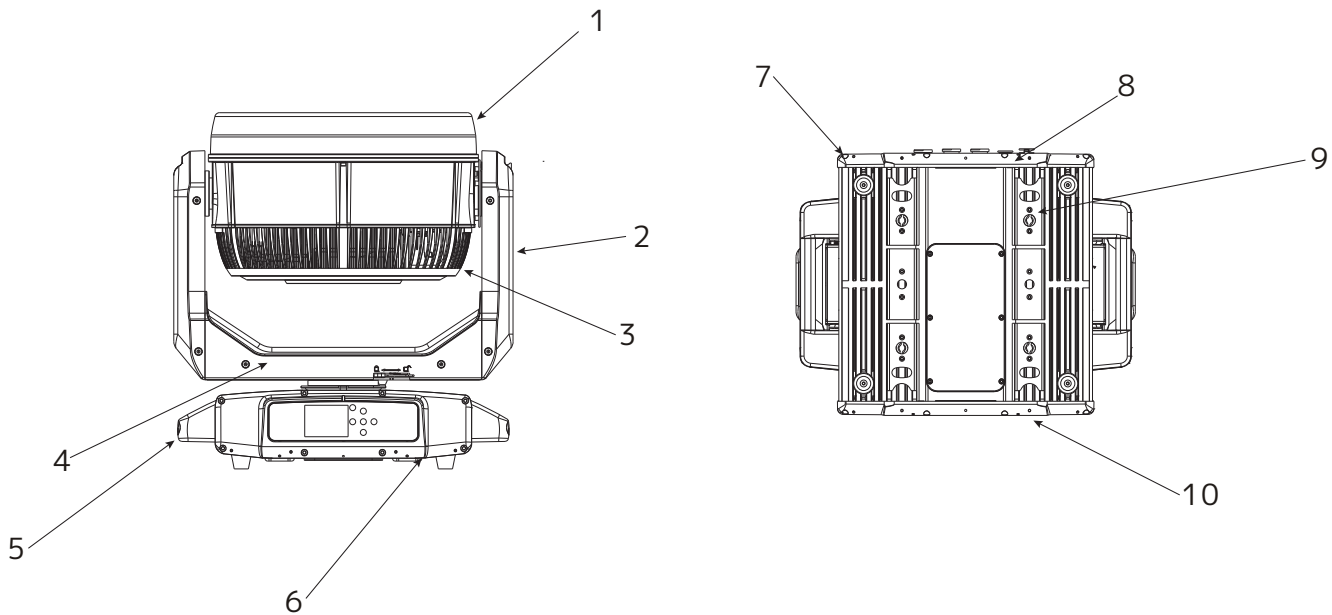

ITEM NO.	DESCRIPTION	TORQUE SETTING
1	Upper Head Cover	8.7 ± 0.9 lb-in (10 ± 1 kgf-cm)
2	Arm Cover	8.7 ± 0.9 lb-in (10 ± 1 kgf-cm)
3	Lower Head Cover	8.7 ± 0.9 lb-in (10 ± 1 kgf-cm)
4	Upper Arm Cover	8.7 ± 0.9 lb-in (10 ± 1 kgf-cm)
5	Handle	20.0 ± 2.0 lb-in (23 ± 2.3 kgf-cm)
6	Display Board	8.7 ± 0.9 lb-in (10 ± 1 kgf-cm)
7	Machine Leg	8.7 ± 0.9 lb-in (10 ± 1 kgf-cm)
8	Bottom Seal Plate	5.2 ± 0.5 lb-in (6 ± 0.6 kgf-cm)
9	Quick Lock Base Holder	8.7 ± 0.9 lb-in (10 ± 1 kgf-cm)
10	XLR Board	8.7 ± 0.9 lb-in (10 ± 1 kgf-cm)

IP TEST PARAMETERS

Following any repair or maintenance procedure that requires disassembly of the fixture, use Elation's IP Tester to confirm the IP integrity of the fixture.

This device features two air valves: one for the head and one for the base. The base air valve is located on the connection panel, beside the Power In port. The head air valve is concealed, and can be accessed by removing the fan shroud on the back of the head. Please refer to the illustration below.

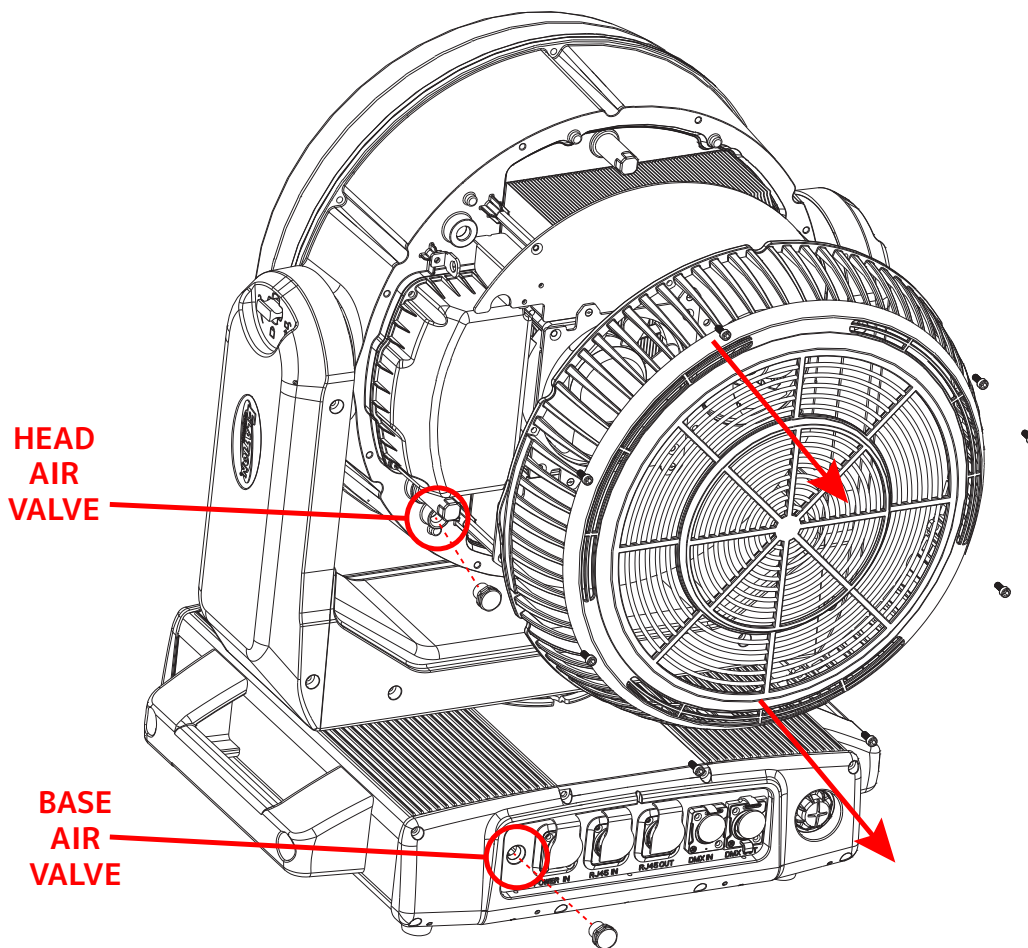

DE-HUMIDIFICATION: IP65 fixtures operating in high-humidity environments may experience residual fogging or condensation. Such fogging will not affect the fixture, and can be removed using the following procedure: position the unit with the air valve pointing upwards, then open the air valve and run the unit for 1-2 hours after reaching operating temperature. Then, while the fixture is still hot, re-install the air valve and allow the unit to cool down. Please note: this procedure should be performed in a dry, climate-controlled environment. Avoid additional fogging by drying the fixture completely before placing into a road case.

IP TEST PARAMETERS



CAUTION! THE USE OF PROTECTIVE GLOVES AND SAFETY GOGGLES IS STRONGLY RECOMMENDED WHILE PERFORMING THE IP PRESSURE TEST! AVOID PLACING YOUR FACE, EYES, HANDS, ETC IN PROXIMITY TO THE LENS OF THE FIXTURE WHILE PERFORMING THE TEST!



IP PRESSURE TESTING PARAMETERS			
Test Type	Minimum Pressure	Maximum Pressure	Steady/Hold Time
Vacuum Test	-4.35 psi (-30.00 KPa)	5.08 psi (-35.00 KPa)	10 sec
Pressure Test	3.62 psi (25.00 KPa)	4.35 psi (30.00 KPa)	10 sec

Please contact Elation Service for information regarding the Elation IP Tester, or visit the product information page online at: <https://www.elationlighting.com/ip-tester>.

REMOTE DEVICE MANAGEMENT (RDM)

NOTE: In order for RDM to work properly, RDM enabled equipment must be used throughout the entire system, including DMX data splitters and wireless systems.

Remote Device Management (RDM) is a protocol that sits on top of the DMX512 data standard for lighting, allowing the DMX systems of the fixtures to be modified and monitored remotely. This protocol is ideal for instances in which a unit is installed in a location that is not easily accessible.

With RDM, the DMX512 system becomes bi-directional, allowing a compatible RDM enabled controller to send out a signal to devices on the wire, as well as allowing the fixture to respond (known as a GET command). The controller can then use its SET command to modify settings that would typically have to be changed or viewed directly via the unit's display screen, including the DMX Address, DMX Channel Mode, and Temperature Sensors.

FIXTURE RDM INFORMATION:

RDM Code	Device ID	Device Model ID	Personality ID
0x61F	Open	1567	Open

Please be aware that not all RDM devices support all RDM features, and therefore it is important to check beforehand to ensure that the equipment that you are considering includes all of the features that you require.

The following parameters are accessible in RDM on this device:

Sensor Definition
Sensor Value
Device Model Description
Manufacturer Label
Device Label
DMX Personality
DMX Personality Description
Device Hours
Pan Invert
Tilt Invert
Display Invert

CONTROL PANEL

This fixture features an easy to navigate system menu. The control panel located on the front of the fixture (see image below) provides access to the main system menu and is where all necessary system adjustments are made to the fixture. During normal operation, pressing the MODE/ESC button once will access the fixture's main menu. Once in the main menu, you can navigate through the different functions and access the sub-menus with the UP, DOWN, RIGHT, and LEFT buttons. Once you reach a field that requires adjusting, press the ENTER button to select that field and use the UP and DOWN buttons to adjust the setting options for that field. Pressing the ENTER button once more will confirm your setting. You may exit the main menu at any time without making any adjustments by pressing the MODE/ESC button.

To access the LCD Menu Control Display via the internal battery, press and hold the MODE/ESC button for 10 seconds. The LCD Menu Control Display will shut OFF automatically about 1 minute from the last button press.

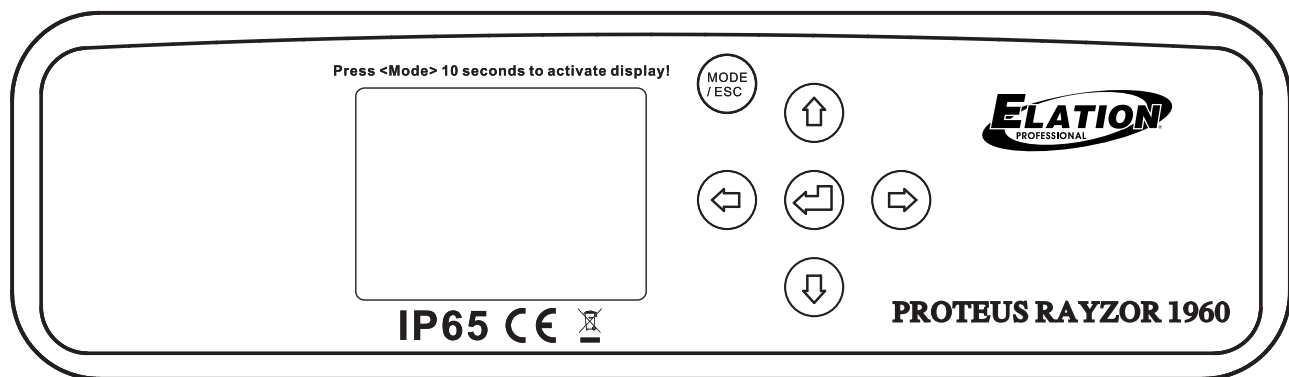

BATTERY

This unit features a dedicated battery that can be used to power the screen display. This allows the user to configure the device's channel mode, DMX address, or any other screen-accessible features without needing to power on the device or even connect it to a power source. To activate the display on battery power, press and hold the MODE button for 3 seconds.

SYSTEM MENU

ELATION PROTEUS RAYZOR 1960 SYSTEM MENU					
Supports Software Versions: 2.0.0					
Features subject to change without notice. Rotation direction (clockwise/counter-clockwise) and control of effects depend on head orientation and pan/tilt settings. Default settings listed in bold .					
MAIN MENU	SUB MENU	OPTIONS / VALUES		DESCRIPTION	
FUNCTION	Set DMX Address	A001 - Axxx			
	DMX Value	ALL...		Displays DMX value	
	Secondary Mode	Secondary1			
		Secondary2			
		Secondary3			
	Auto Program	Primary		Auto Program	
Alone					
INFORMATION	Time Information	Current Time	xxxx hours	Power On Running Time	
		Total Run Time	xxxx hours	Fixture running time	
		Last Run Time	xxxx hours	Run time since last reset	
		Clear Last Run Password = 038	On / Off	Clear last run time	
	Temperature Info	LED Temperature	xxx °C / °F		
		Head Temperature	xxx °C / °F		
		Base Temperature	xxx °C / °F		
	Humidity Info	Head Humidity	xxx %		
		Base Humidity	xxx %		
	Ethernet IP	Ethernet IP xxx. xxx. xxx. xxx xxx. xxx. xxx. xxx			
	Fan Info	Head Fan 1	xxxx RPM		
			
	Software Info	Vx.x.x			
	Error Info	Error Record 1	Pan...		
....		...			
Error Record 10		Pan...			
PERSONALITY	Status Settings	Address via DMX	On / Off		
		No DMX Status	SunProt	Select operation mode when DMX signal is lost or interrupted	
			Close		
			Hold		
			Auto		
		Pan Reverse	On / Off		
		Tilt Reserve	On / Off		
		Pan Degree	360 / 540		
		Tilt Degree	360 / 270		
		Pan Tilt Path	Shortest Path		
Continue Path					

CONTINUED ON NEXT PAGE

SYSTEM MENU

ELATION PROTEUS RAYZOR 1960 SYSTEM MENU					
MAIN MENU	SUB MENU	OPTIONS / VALUES		DESCRIPTION	
PERSONALITY (continued)	Status Settings (continued)	Zoom Speed	Fast / Normal		
		Feedback	On / Off		Movement Feedback
		Hibernation	Off, 01min - 99min		Default = 15min
	Service Setting	Password = 050			
		Clear Err Info	On / Off		Clear Error Info
	Fans Control	Auto			
		High			
		Silent			
		Studio			
		Mute			
	Display Setting	Shutoff Time	02min - 60min		Default = 05min
		Display Reverse	Off		Normal orientation
			On		Inverted orientation
			Auto		Automatically switch orientation to keep display upright
	Key Lock	On / Off			
	Temperature C/F	Celsius / Fahren			
	Initial Status	Pan = xxx ...		Initial effect position	
	Select Signal	DMX Only			
		Art-Net			
		sACN			
	Klingnet	On / Off			
	Ethernet IP	xxx. xxx. xxx. xxx			
	Ether Mask IP	xxx. xxx. xxx. xxx			
	Set Universe	000 - 32767		Set Art-Net universe	
	DHCP	On / Off		Auto assign IP address	
	Dimmer Mode	Standard			
		Stage			
		TV			
		Architectural			
		Theatre			
		Stage2			
		Delay	0s, 0.1s...10s		
Refresh	900Hz - 25KHz		Default = 1200Hz		
Dimmer Curve	Linear				
	Square				
	Inverse Square				
	S-Curve				
Reset Def	On	Passcode = 050		Restore to factory settings	
	Off				

CONTINUED ON NEXT PAGE

SYSTEM MENU

ELATION PROTEUS RAYZOR 1960 SYSTEM MENU					
MAIN MENU	SUB MENU	OPTIONS / VALUES		DESCRIPTION	
RESET FUNCTION	Reset All				
	Reset Pan & Tilt				
	Reset Others				
EFFECT ADJUST	Test Channel	Pan...			
	Manual Control	Pan = xxx ...		Use for fine adjustment	
	Calibration	Passcode = 050 Pan = xxx ...		Calibrate and adjust effects	
USER MODE SET	User Mode	Standard			
		Pixels			
		Extended			
EDIT PROGRAM	Select Program	Auto Pro Part 1 = Program 1 - 10		Default = Program 1	
		Auto Pro Part 2 = Program 1 - 10		Default = Program 1	
		Auto Pro Part 3 = Program 1 - 10		Default = Program 1	
	Edit Program	Prog 1 : Prog 10	Prog Test		Testing Program
			Step 01 = SCxxx		Program In Loop
			Step 64 = SCxxx		Save and Exit
	Edit Scenes	Scene 001 - Scene 250	Pan, Tilt,....		Save and automatically return to manual scenes edit
			-- Fade Time --		
			-- Scene Time --		
			Input by Out		
Rec. Controller	xx ~ xx		Automatic scenes recorder		

RECORD CONTROLLER

The fixture features an integrated DMX recorder that can be used to transmit the programmed scenes from your DMX controller to the moving head. Adjust the desired scene numbers via the encoder (from – to). When you call up the scenes with your controller, they will automatically be transmitted to the moving head.

WORKING WITH BUILT-IN PROGRAMS

A Primary unit can send up to 3 different data groups to the Secondary units. In other words, a Primary unit can operate up to 3 different Secondary units, with each Secondary unit operating a different set of programs. The Primary unit sends the 3 program parts in a continuous loop.



The Secondary unit receives data from the Primary unit according to the group that the Secondary unit was assigned to. For example, suppose we have a unit that has been assigned as a “Secondary 1” unit. Upon receiving the 3-part Auto Program from the Primary unit, the Secondary 1 unit will implement Part 1 of the Auto Program, while ignoring Part 2 and Part 3.

To start running an Auto Program, follow the directions below:

- 1. Set the Secondary unit(s) to the desired Secondary group.** In the main menu of any unit that you want to set as a Secondary, navigate to Function > Secondary Mode. Select “Secondary 1”, “Secondary 2”, or “Secondary 3” to designate the desired Secondary group. Press ENTER to confirm, and press MODE/ESC to return to the main menu,
- 2. Set the Primary unit.** In the Main Menu of the unit you want to set as the Primary, navigate to Function > Auto Program. Select “Primary” and press ENTER to confirm. Then press MODE/ESC to return to the main menu.
- 3. Program selection for each part of the Auto Program.** In the main menu of the Primary unit, navigate to Edit Program > Select Programs. Select “Auto Pro Part 1”, then select which program (1 - 10) to set as Part 1. Press ENTER to confirm. Repeat the process for “Auto Pro Part 2” and “Auto Pro Part 3”.
- 4. Program selection for edit program.** In the main menu of the Primary unit, navigate to Edit Program > Edit Program, then press ENTER. Select the desired program to edit specific scenes into a specific program, then press ENTER to confirm.
- 5. Automatic Scene Recording.** In the main menu of the Primary unit, navigate to Edit Program > Edit Scenes, then press ENTER. Select the desired scene numbers, noting that a maximum of 250 scenes can be programmed. Press ENTER to confirm.

See the following page for an example.

RECORD CONTROLLER

EXAMPLE: WORKING WITH BUILT-IN PROGRAMS

Program 2 includes scenes: 10, 11, 12, & 13

Program 4 includes scenes: 8, 9, & 10

Program 6 includes scenes: 12, 13, 14, & 15

Auto Pro Part 1 is Program 2

Auto Pro Part 2 is Program 3

Auto Pro Part 3 is Program 6

The 3 Secondary groups run the Auto Program in certain time segments, as illustrated in the diagram below.

Part 1:

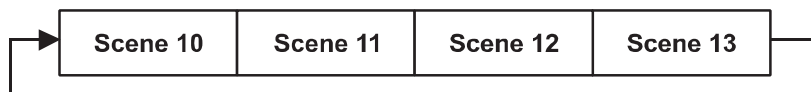

Part 2:

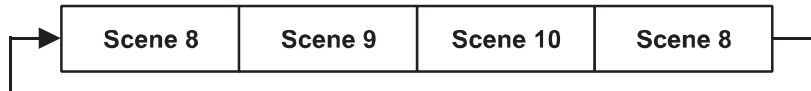

Part 3:

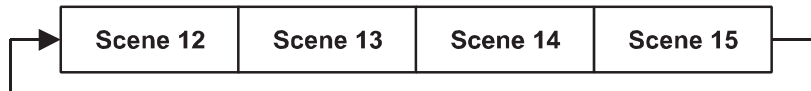

FAN CONTROL AND LOW NOISE OPERATION

The Proteus Rayzor 1960 is a high-performance fixture suited for multiple applications. For noise critical environments such as Theater, Opera, or Orchestral Halls, it offers various fan operation modes which remove unwanted noise distractions for the audience and performers. Fan Modes can be changed remotely via the DMX control channel, allowing the fixture to offer high output or whisper-silent operation at a moment's notice. All Fan Modes smoothly transition over a brief period, preventing unwanted attraction to the fixture.

Auto (Default) – Fans only run at the speeds needed to keep the LED engine within a safe temperature range, and ensures optimal performance of the fixture. They will turn off if possible; for example, when the fixture is dimmed to a low intensity. Fans sense the ambient and fixture temperature and will, at all times, try to keep noise levels at a minimum. The fixture output will only be reduced when the LED engine cannot be cooled to its safe operating range due to a high ambient temperature.

NOTE: This mode is recommended for daily operation.

Silent – Fan speeds are reduced throughout the fixture for a lower noise profile. The fixture output is also reduced to approximately 80%. This mode should be sufficient for most uses where lower noise is required.

High – Fan speeds are increased throughout the fixture for the most efficient cooling. This mode will increase wear on the fans and should only be utilized in exceptional circumstances. Fans will always run, even if the fixture is dimmed. Fixture output is kept at 100% unless the LED engine temperature reaches an unsafe temperature, at which point the fixture will reduce power carefully to ensure continued safe operation. This mode is only required in very high ambient temperatures when automatic fan speed adjustments are not desired.

Low Noise Modes

For very critical noise environments, the fixture offers two additional Low Noise Modes for silent operation. The fixture output will be reduced, yet due to the extremely high luminous flux, the fixture still offers outstanding performance. In Low Noise Modes, all parameters of the fixture operate more quietly with reduced fan speeds.

Studio – Almost all fixture fans are turned off, and only run when absolutely necessary. The fixture LED power output is reduced to 50%.

Mute – All but one fixture fan is turned off for whisper-quiet operation. The fixture LED power output is reduced to 25%.

LIGHTING CONSOLE PATCHING GUIDELINES

The PROTEUS RAYZOR 1960 is a versatile luminaire which combines two fixtures into one housing, allowing it to produce multiple unique lighting effects typically not found in a single lighting fixture. The DMX layout is designed to offer a variety of options for controlling each fixture efficiently.

The main fixture contains 19 x 60W RGBW pixel cells, while the SparkLED fixture contains 76 x 2W white LEDs. For ease of use the DMX layout is arranged to allow lighting consoles to separate the fixture into multiple segments or parts. It is especially important to arrange the fixture in such segments or parts when using the fixture in the full extended 176 channel DMX mode. For simpler programming, reduced DMX channel modes can be used. However, for easy recall of interesting pixel animations, both the RGBW and SparkLED fixtures contain two FX systems: one which controls the RGBW cells, and a second that is dedicated to the SparkLEDs.

The pixels are arranged in a grid pattern as illustrated below. (RGBW 1-19 | SparkLED 1-76)

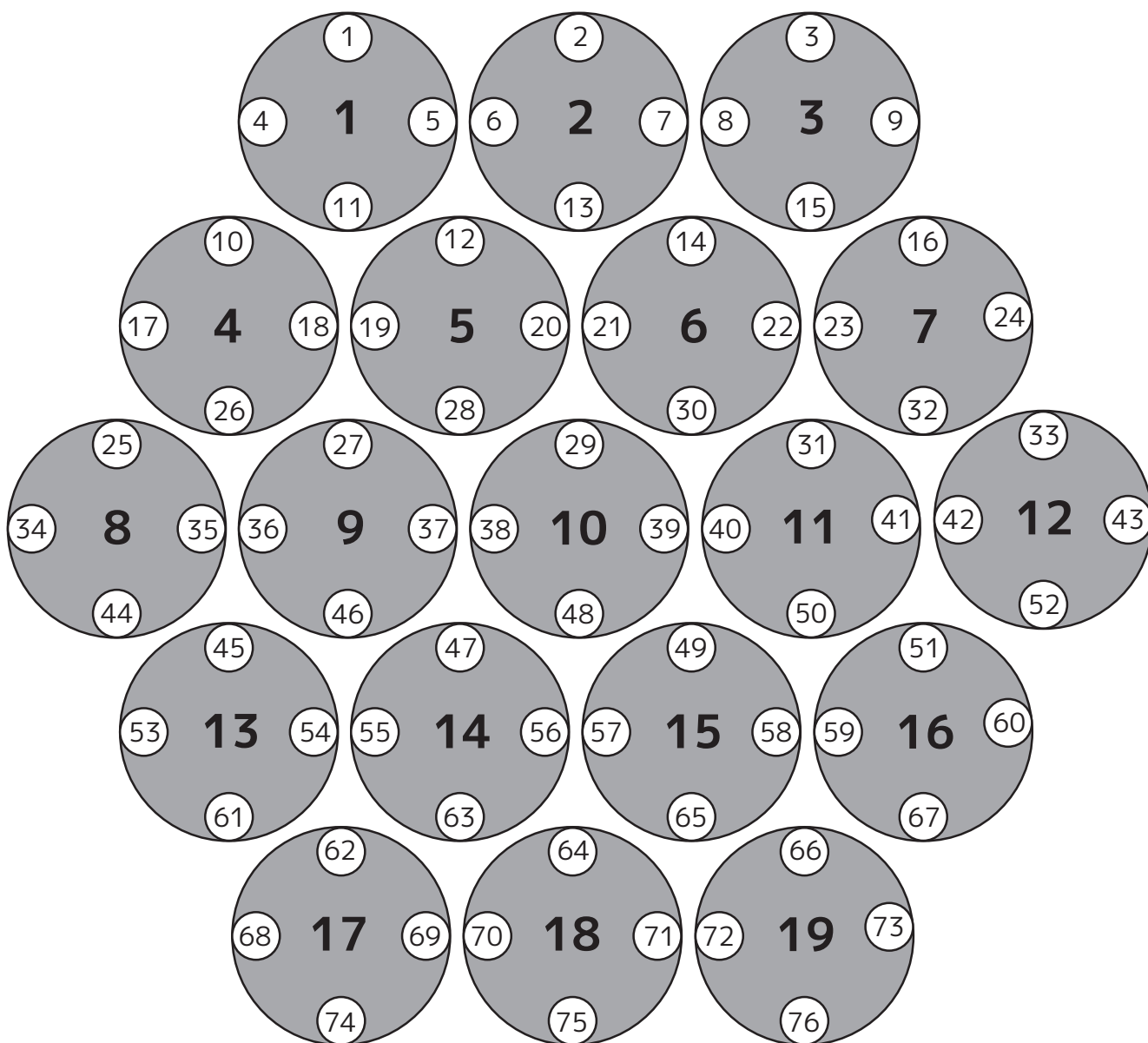

LIGHTING CONSOLE PATCHING GUIDELINES

CATEGORY	GROUP	PIXELS
RGBW Pixel Columns	Column 1	8
	Column 2	4, 13
	Column 3	1, 9, 17
	Column 4	5, 14
	Column 5	2, 10, 18
	Column 6	6, 15
	Column 7	3, 11, 19
	Column 8	7, 16
	Column 9	12
RGBW Pixel Rows	Row 1	1 - 3
	Row 2	4 - 7
	Row 3	8 - 12
	Row 4	13 - 16
	Row 5	17 - 19
RGBW Pixel Rings	Ring 1	1, 2, 3, 7, 12, 16, 19, 18, 17, 13, 8, 4
	Ring 2	5, 6, 11, 15, 14, 9
	Ring 3	10
Spark LED Rows	Row 1	1 - 3
	Row 2	4 - 9
	Row 3	10 - 16
	Row 4	17 - 24
	Row 5	25 - 33
	Row 6	34 - 43
	Row 7	44 - 52
	Row 8	53 - 60
	Row 9	61 - 67
	Row 10	68 - 73
	Row 11	74 - 76
Spark LED Rings	Ring 1	1, 2, 3, 9, 16, 24, 33, 43, 52, 60, 67, 73, 76, 75, 74, 68, 61, 53, 44, 34, 25, 17, 10, 4
	Ring 2	5, 6, 7, 8, 15, 23, 32, 41+42, 51, 59, 66, 72, 71, 69, 70, 62, 54, 45, 35+36, 26, 18, 11
	Ring 3	13, 14, 22, 31, 50, 58, 65, 64, 63, 55, 46, 27, 19, 12
	Ring 4	20, 21, 3, 40, 49, 57, 56, 47, 37, 28, 20
	Ring 5	29, 39, 48, 38

LIGHTING CONSOLE PATCHING GUIDELINES

There are also two additional parts for a primary control of the PROTEUS RAYZOR 1960, which creates four separate control areas for the fixture. It is recommended to create fixture groups on the lighting controller for each area of the fixture. (see below)

Main Fixture	Primary Pan, Tilt, RGBW Color, Strobe, Dimmer, Zoom, FX Controls
RGBW Cells 1-19	Red, Green, Blue, White per each individual cell
Spark LED Main	Primary Spark LED Strobe, Dimmer
Spark LEDs 1-76	Spark LED Dimmer per each individual LED

SparkLED is not available as a mode in the fixture menu but must be provided as a console control profile for easy programming of the fixture. Use the PROTEUS RAYZOR 1960 in Extended mode and patch appropriate parts of the RGBW Pixels and SparkLED fixtures on your control system to access all 176 channels.

On the lighting controller, patch the two fixture types (RGBW and SparkLED), separating the SparkLEDs into a different ID range. (see below)

RGBW Pixels for Channels 1-98

SparkLEDs for Channels 99-176

ONYX Main and Sub Fixture ID patch example below for a single PROTEUS RAYZOR 1960 fixture.

ID	TYPE	ADDRESS
1.0	RGBW Pixels Main	1
1.1	Pixel 1	22
1.2	Pixel 2	26
1.3	Pixel 3	30
1.4	Pixel 4	34
1.5	Pixel 5	38
...
1.19	Pixel 19	94
1.20	Spark LED Main	98

101.1	Spark LED 1	101
101.2	Spark LED 2	102
101.3	Spark LED 3	103
101.4	Spark LED 4	104
...
101.76	Spark LED 76	176

LIGHTING CONSOLE PATCHING GUIDELINES

ONLYX screen shots below illustrate Main and Sub Fixture ID patch for a single PROTEUS RAYZOR 1960 fixture.

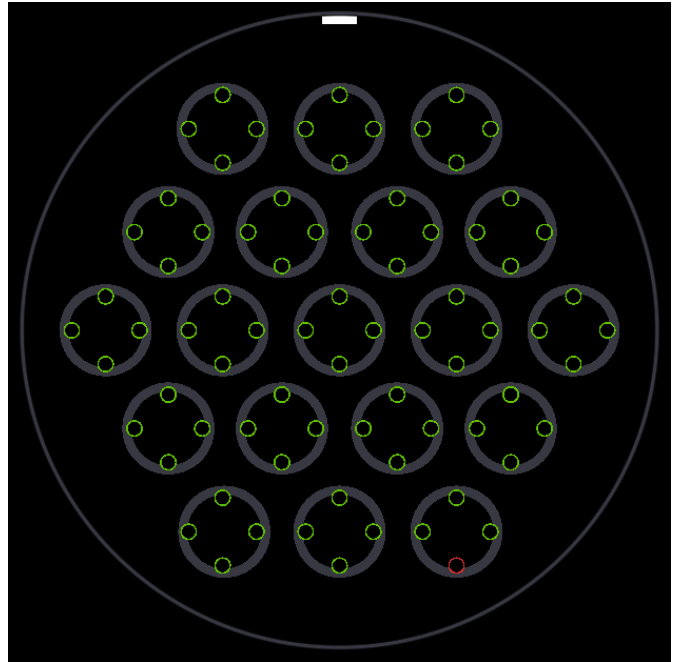
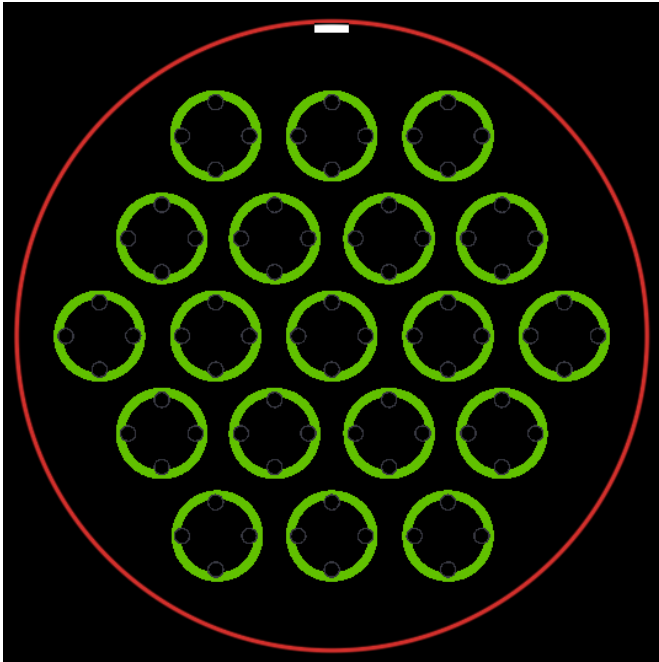

← Back

Tasks

- Patch
- Cloning
- Swap
- RDM
- Import

ID	Name	Type	Universe	Address	Invert
1		Proteus Rayzor 1960 - Primary Pixels (Main)	1	1	
1.1		Proteus Rayzor 1960 - Primary Pixels (RGBW 1)	Auto	Auto	
1.2		Proteus Rayzor 1960 - Primary Pixels (RGBW 2)	Auto	Auto	
1.3		Proteus Rayzor 1960 - Primary Pixels (RGBW 3)	Auto	Auto	
1.4		Proteus Rayzor 1960 - Primary Pixels (RGBW 4)	Auto	Auto	
1.5		Proteus Rayzor 1960 - Primary Pixels (RGBW 5)	Auto	Auto	
1.6		Proteus Rayzor 1960 - Primary Pixels (RGBW 6)	Auto	Auto	
1.7		Proteus Rayzor 1960 - Primary Pixels (RGBW 7)	Auto	Auto	
1.8		Proteus Rayzor 1960 - Primary Pixels (RGBW 8)	Auto	Auto	
1.9		Proteus Rayzor 1960 - Primary Pixels (RGBW 9)	Auto	Auto	
1.10		Proteus Rayzor 1960 - Primary Pixels (RGBW 10)	Auto	Auto	
1.11		Proteus Rayzor 1960 - Primary Pixels (RGBW 11)	Auto	Auto	
1.12		Proteus Rayzor 1960 - Primary Pixels (RGBW 12)	Auto	Auto	
1.13		Proteus Rayzor 1960 - Primary Pixels (RGBW 13)	Auto	Auto	
1.14		Proteus Rayzor 1960 - Primary Pixels (RGBW 14)	Auto	Auto	
1.15		Proteus Rayzor 1960 - Primary Pixels (RGBW 15)	Auto	Auto	
1.16		Proteus Rayzor 1960 - Primary Pixels (RGBW 16)	Auto	Auto	
1.17		Proteus Rayzor 1960 - Primary Pixels (RGBW 17)	Auto	Auto	
1.18		Proteus Rayzor 1960 - Primary Pixels (RGBW 18)	Auto	Auto	
1.19		Proteus Rayzor 1960 - Primary Pixels (RGBW 19)	Auto	Auto	
1.20		Proteus Rayzor 1960 - Primary Pixels (SparkLED)	Auto	Auto	

ID	Name	Type	Universe	Address	Invert
101		Proteus Rayzor 1960 - SparkLED	1	101	
101.1		Proteus Rayzor 1960 - SparkLED (SparkLED 1)	Auto	Auto	
101.2		Proteus Rayzor 1960 - SparkLED (SparkLED 2)	Auto	Auto	
101.3		Proteus Rayzor 1960 - SparkLED (SparkLED 3)	Auto	Auto	
101.4		Proteus Rayzor 1960 - SparkLED (SparkLED 4)	Auto	Auto	
101.5		Proteus Rayzor 1960 - SparkLED (SparkLED 5)	Auto	Auto	
101.6		Proteus Rayzor 1960 - SparkLED (SparkLED 6)	Auto	Auto	
101.7		Proteus Rayzor 1960 - SparkLED (SparkLED 7)	Auto	Auto	
101.8		Proteus Rayzor 1960 - SparkLED (SparkLED 8)	Auto	Auto	
101.9		Proteus Rayzor 1960 - SparkLED (SparkLED 9)	Auto	Auto	
101.10		Proteus Rayzor 1960 - SparkLED (SparkLED 10)	Auto	Auto	
101.11		Proteus Rayzor 1960 - SparkLED (SparkLED 11)	Auto	Auto	
101.12		Proteus Rayzor 1960 - SparkLED (SparkLED 12)	Auto	Auto	
101.13		Proteus Rayzor 1960 - SparkLED (SparkLED 13)	Auto	Auto	
101.14		Proteus Rayzor 1960 - SparkLED (SparkLED 14)	Auto	Auto	
101.15		Proteus Rayzor 1960 - SparkLED (SparkLED 15)	Auto	Auto	
101.16		Proteus Rayzor 1960 - SparkLED (SparkLED 16)	Auto	Auto	

Actions

Commands

Choose Type

Universe 1

Fixtures

LIGHTING CONSOLE PATCHING GUIDELINES

ONYX groups example below for easier selection of a single PROTEUS RAYZOR 1960 fixture.

Group Name	Group Content
All RGBW Pixels Main	1
All RGBW Pixels	1.1, 1.2, ... 1.20
All Spark LEDs Main	1.20
All Spark LEDs	101.1, 101.2, ... 101.76

ONYX screen shots below illustrate both Primary (top) and SparkLED (bottom) Groups for a single PROTEUS RAYZOR 1960 fixture.

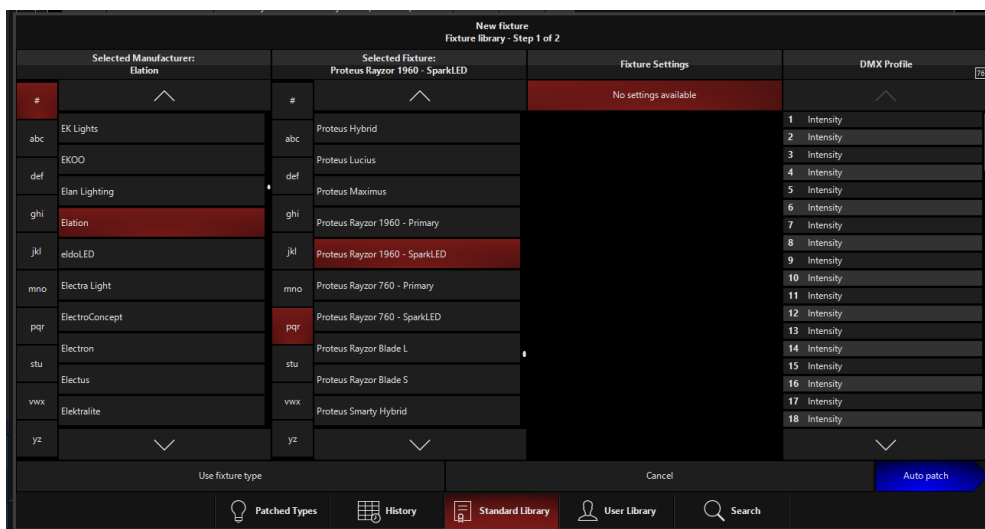
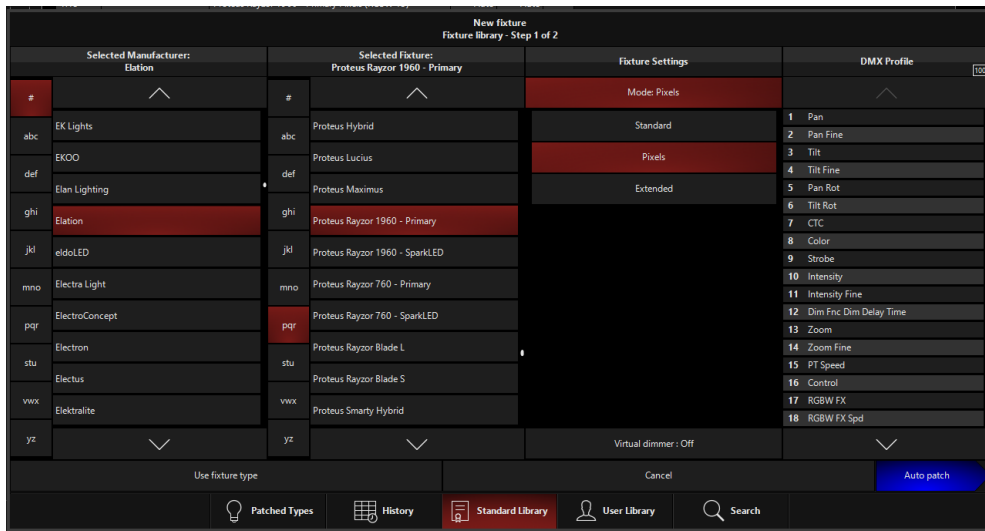

DMX TRAITS

ELATION PROTEUS RAYZOR 1960 DMX Channel Traits						
Supports Software Versions: 2.0.0						
Features subject to change without notice. Rotation direction (clockwise/counter-clockwise) and control of effects depends on head orientation and pan/tilt settings.						
CHANNEL			DMX VALUES	FUNCTION	FADE STATUS	DEFAULT VALUE
STANDARD	PIXELS	EXTENDED				
1	1	1	000 - 255	Pan Movement	Fade	127
2	2	2	000 - 255	Pan Fine Movement	Fade	127
3	3	3	000 - 255	Tilt Movement	Fade	127
4	4	4	000 - 255	Tilt Fine Movement	Fade	127
5	5	5		Pan Rotate	Fade	0
			000 - 002	Disabled		
			003 - 126	Clockwise Rotation, fast to slow		
			127 - 129	No Rotation (fixture stops at current position)		
			130 - 253	Counter-Clockwise Rotation, slow to fast		
	254 - 255	No Rotation (fixture stops at current position)				
6	6	6		Tilt Rotate	Fade	0
			000 - 002	Disabled		
			003 - 126	Clockwise Rotation, fast to slow		
			127 - 129	No Rotation (fixture stops at current position)		
			130 - 253	Counter-Clockwise Rotation, slow to fast		
	254 - 255	No Rotation (fixture stops at current position)				
7	7	7		CTC	Fade	0
			000 - 010	Disabled		
			011 - 171	Color Temperature, 100K steps from 2000K to 10,000K (see CTC Table section of this manual)		
	172 - 255	10,000K				
8	8	8		Color Wheel	Snap	0
			000 - 009	Open		
			010 - 014	Red		
			015 - 019	Red Orange		
			020 - 024	Light Amber		
			025 - 029	Yellow Amber		
			030 - 034	Greenish Yellow		
			035 - 039	Light Yellow Green		
			040 - 044	Dark Yellow Green		
045 - 049	Green					

CONTINUED ON NEXT PAGE

DMX TRAITS

CHANNEL			DMX VALUES	FUNCTION	FADE STATUS	DEFAULT VALUE
STANDARD	PIXELS	EXTENDED				
8	8	8		Color Wheel (continued)	Snap	0
			050 - 054	Teal		
			055 - 059	Cyan		
			060 - 064	Light Blue		
			065 - 069	Aqua		
			070 - 074	Dark Aqua		
			075 - 079	Green Blue		
			080 - 084	Light Lavender		
			085 - 089	Dark Purple		
			090 - 094	Medium Purple		
			095 - 099	Mid Rose		
			100 - 104	Mauve		
			105 - 109	Nice Magenta		
			110 - 114	Warm Magenta		
			115 - 119	Light Red		
			120 - 124	Straw		
			125 - 129	Dark CTB		
			130 - 134	Light Green		
			135 - 139	Purple		
			140 - 144	Lighter Purple		
			145 - 149	Pink		
			150 - 154	Rose		
			155 - 159	White		
			164 - 174	No Function		
			175 - 179	Open		
				Color Scroll		
			180 - 201	Clockwise Scroll, fast to slow		
			202 - 207	Stop		
			208 - 229	Counter-Clockwise Scroll, slow to fast		
			230 - 234	Open		
	Random Slots					
235 - 239	Fast					
240 - 244	Medium					
245 - 249	Slow					
250 - 255	Open					

CONTINUED ON NEXT PAGE

DMX TRAITS

CHANNEL			DMX VALUES	FUNCTION	FADE STATUS	DEFAULT VALUE
STANDARD	PIXELS	EXTENDED				
9	9	9		Strobe	Snap	50
			000 - 031	Shutter Closed		
			032 - 063	Shutter Open		
			064 - 095	Strobe, slow to fast		
			096 - 127	Fast Close, Slow Open		
			128 - 159	Fast Open, Slow Close		
			160 - 191	Pulse Effects		
			192 - 223	Random Strobe, slow to fast		
224 - 255	Shutter Open					
10	10	10	000 - 255	Dimmer , 0% to 100%	Fade	0
11	11	11	000 - 255	Dimmer Fine	Fade	0
12	12	12		Dim Modes	Snap	0
			000 - 020	Standard		
			021 - 040	Stage		
			041 - 060	TV		
			061 - 080	Architectural		
			081 - 100	Theatre		
			101 - 120	Stage 2		
				Dimmer Delay Time		
			121	0s		
			122	0.1s		
			123	0.2s		
			124	0.3s		
			125	0.4s		
			126	0.5s		
			127	0.6s		
			128	0.7s		
			129	0.8s		
			130	0.9s		
			131	1.0s		
			132	1.5s		
			133	2.0s		
			134	3.0s		
			135	4.0s		
			136	5.0s		
137	6.0s					
138	7.0s					
139	8.0s					
140	9.0s					
141	10.0s					
142 - 255	Idle					

CONTINUED ON NEXT PAGE

DMX TRAITS

CHANNEL			DMX VALUES	FUNCTION	FADE STATUS	DEFAULT VALUE
STANDARD	PIXELS	EXTENDED				
13	13	13		Zoom	Fade	0
			000 - 245	Zoom, wide to narrow		
			246 - 255	Overdrive, minimum to maximum		
	14	14	000 - 255	Zoom Fine	Fade	0
	15	15		Pan/Tilt Speed	Snap	0
			000 - 225	Speed, maximum to minimum		
			226 - 235	Blackout when pan/tilt moves		
			236 - 245	Blackout when all wheels change		
			246 - 255	No function		
14	16	16		Control	Snap	0
			000 - 010	Idle		
			011 - 012	Pan/Tilt Shortest Path		
			013 - 014	Pan/Tilt Continue Path (default)		
			015 - 016	Pan Range 540 (default)		
			017 - 018	Pan Range 360		
			019 - 020	Tilt Range 270 (default)		
			021 - 022	Tilt Range 360		
			023 - 039	Idle		
			040 - 044	Fan Mode Mute		
			045 - 049	Fan Mode Studio		
			050 - 059	Fan Mode Silent		
			060 - 069	Fan Mode High		
			070 - 079	Fan Mode Auto (default)		
			080 - 084	Reset All		
			085 - 087	Reset Movement		
			088 - 091	Reset Zoom		
			092 - 099	Idle		
				Refresh Rate (Hz)		
			100	900		
			101	910		
			102	920		
			103	930		
			104	940		
			105	950		
106	960					
107	970					
108	980					
109	990					
110	1000					
111	1010					
112	1020					

CONTINUED ON NEXT PAGE

DMX TRAITS

CHANNEL			DMX VALUES	FUNCTION	FADE STATUS	DEFAULT VALUE
STANDARD	PIXELS	EXTENDED				
14	16	16		Refresh (Hz) (continued)	Snap	0
			113	1030		
			114	1040		
			115	1050		
			116	1060		
			117	1070		
			118	1080		
			119	1090		
			120	1100		
			121	1110		
			122	1120		
			123	1130		
			124	1140		
			125	1150		
			126	1160		
			127	1170		
			128	1180		
			129	1190		
			130	1200		
			131	1210		
			132	1220		
			133	1230		
			134	1240		
			135	1250		
			136	1260		
			137	1270		
			138	1280		
			139	1290		
			140	1300		
			141	1310		
			142	1320		
			143	1330		
			144	1340		
145	1350					
146	1360					
147	1370					
148	1380					
149	1390					
150	1400					
151	1410					
152	1420					

CONTINUED ON NEXT PAGE

DMX TRAITS

CHANNEL			DMX VALUES	FUNCTION	FADE STATUS	DEFAULT VALUE
STANDARD	PIXELS	EXTENDED				
14	16	16		Refresh (Hz) (continued)	Snap	0
			153	1430		
			154	1440		
			155	1450		
			156	1460		
			157	1470		
			158	1480		
			159	1490		
			160	1500		
			161	2500		
			162	4000		
			163	5000		
			164	6000		
			165	10000		
			166	15000		
			167	20000		
			168	25000		
			169 - 192	Idle		
			193 - 194	Hibernate Off		
			195 - 196	Hibernate On		
			197 - 198	Sun Protection On		
			199 - 200	Sun Protection Off		
			201 - 210	Dimmer Curve Linear (default)		
			211 - 220	Dimmer Curve Square		
			221 - 230	Dimmer Curve Inverse Square		
			231 - 240	Dimmer Curve S-Curve		
241 - 242	Zoom Speed - Slow					
243 - 244	Zoom Speed - Fast (default)					
245 - 249	Idle					
250 - 251	Display Off					
252 - 253	Display On					
254 - 255	Idle					
15	17	17	000 - 255	RGBW FX (see RGBW Pixel FX Table section of this manual)	Snap	0
16	18	18		RGBW FX Speed	Fade	160
			000 - 126	Reverse, fast to slow		
			127 - 128	Stop		
			129 - 255	Forward, slow to fast		
17	19	19	000 - 255	Spark LED FX (see Spark LED FX Table section of this manual)	Snap	0
CONTINUED ON NEXT PAGE						

DMX TRAITS

CHANNEL			DMX VALUES	FUNCTION	FADE STATUS	DEFAULT VALUE
STANDARD	PIXELS	EXTENDED				
18	20	20		Spark LED FX Speed	Fade	160
			000 - 126	Reverse, fast to slow		
			127 - 128	Stop		
			129 - 255	Forward, slow to fast		
19	21	21		FX Offset	Snap	0
			000	Idle		
			001 - 035	Fixture Offset, 10 degrees to 350 degrees		
			036	Synchronized		
			037 - 100	No Function		
			101 - 120	Random Fixture Offset		
			121 - 140	Random Pixel Order		
			141 - 255	Random Steps		
20	22	22	000 - 255	Red , 0% to 100%	Fade	255
21	23	23	000 - 255	Green , 0% to 100%	Fade	255
22	24	24	000 - 255	Blue , 0% to 100%	Fade	255
23	25	25	000 - 255	White , 0% to 100%	Fade	255
	26	26	000 - 255	Red 2 , 0% to 100%	Fade	255
	27	27	000 - 255	Green 2 , 0% to 100%	Fade	255
	28	28	000 - 255	Blue 2 , 0% to 100%	Fade	255
	29	29	000 - 255	White 2 , 0% to 100%	Fade	255
	30	30	000 - 255	Red 3 , 0% to 100%	Fade	255
	31	31	000 - 255	Green 3 , 0% to 100%	Fade	255
	32	32	000 - 255	Blue 3 , 0% to 100%	Fade	255
	33	33	000 - 255	White 3 , 0% to 100%	Fade	255
	34	34	000 - 255	Red 4 , 0% to 100%	Fade	255
	35	35	000 - 255	Green 4 , 0% to 100%	Fade	255
	36	36	000 - 255	Blue 4 , 0% to 100%	Fade	255
	37	37	000 - 255	White 4 , 0% to 100%	Fade	255
	38	38	000 - 255	Red 5 , 0% to 100%	Fade	255
	39	39	000 - 255	Green 5 , 0% to 100%	Fade	255
	40	40	000 - 255	Blue 5 , 0% to 100%	Fade	255
	41	41	000 - 255	White 5 , 0% to 100%	Fade	255
	42	42	000 - 255	Red 6 , 0% to 100%	Fade	255
	43	43	000 - 255	Green 6 , 0% to 100%	Fade	255
	44	44	000 - 255	Blue 6 , 0% to 100%	Fade	255
	45	45	000 - 255	White 6 , 0% to 100%	Fade	255
	46	46	000 - 255	Red 7 , 0% to 100%	Fade	255
	47	47	000 - 255	Green 7 , 0% to 100%	Fade	255
	48	48	000 - 255	Blue 7 , 0% to 100%	Fade	255
	49	49	000 - 255	White 7 , 0% to 100%	Fade	255

CONTINUED ON NEXT PAGE

DMX TRAITS

CHANNEL			DMX VALUES	FUNCTION	FADE STATUS	DEFAULT VALUE
STANDARD	PIXELS	EXTENDED				
	50	50	000 - 255	Red 8 , 0% to 100%	Fade	255
	51	51	000 - 255	Green 8 , 0% to 100%	Fade	255
	52	52	000 - 255	Blue 8 , 0% to 100%	Fade	255
	53	53	000 - 255	White 8 , 0% to 100%	Fade	255
	54	54	000 - 255	Red 9 , 0% to 100%	Fade	255
	55	55	000 - 255	Green 9 , 0% to 100%	Fade	255
	56	56	000 - 255	Blue 9 , 0% to 100%	Fade	255
	57	57	000 - 255	White 9 , 0% to 100%	Fade	255
	58	58	000 - 255	Red 10 , 0% to 100%	Fade	255
	59	59	000 - 255	Green 10 , 0% to 100%	Fade	255
	60	60	000 - 255	Blue 10 , 0% to 100%	Fade	255
	61	61	000 - 255	White 10 , 0% to 100%	Fade	255
	62	62	000 - 255	Red 11 , 0% to 100%	Fade	255
	63	63	000 - 255	Green 11 , 0% to 100%	Fade	255
	64	64	000 - 255	Blue 11 , 0% to 100%	Fade	255
	65	65	000 - 255	White 11 , 0% to 100%	Fade	255
	66	66	000 - 255	Red 12 , 0% to 100%	Fade	255
	67	67	000 - 255	Green 12 , 0% to 100%	Fade	255
	68	68	000 - 255	Blue 12 , 0% to 100%	Fade	255
	69	69	000 - 255	White 12 , 0% to 100%	Fade	255
	70	70	000 - 255	Red 13 , 0% to 100%	Fade	255
	71	71	000 - 255	Green 13 , 0% to 100%	Fade	255
	72	72	000 - 255	Blue 13 , 0% to 100%	Fade	255
	73	73	000 - 255	White 13 , 0% to 100%	Fade	255
	74	74	000 - 255	Red 14 , 0% to 100%	Fade	255
	75	75	000 - 255	Green 14 , 0% to 100%	Fade	255
	76	76	000 - 255	Blue 14 , 0% to 100%	Fade	255
	77	77	000 - 255	White 14 , 0% to 100%	Fade	255
	78	78	000 - 255	Red 15 , 0% to 100%	Fade	255
	79	79	000 - 255	Green 15 , 0% to 100%	Fade	255
	80	80	000 - 255	Blue 15 , 0% to 100%	Fade	255
	81	81	000 - 255	White 15 , 0% to 100%	Fade	255
	82	82	000 - 255	Red 16 , 0% to 100%	Fade	255
	83	83	000 - 255	Green 16 , 0% to 100%	Fade	255
	84	84	000 - 255	Blue 16 , 0% to 100%	Fade	255
	85	85	000 - 255	White 16 , 0% to 100%	Fade	255
	86	86	000 - 255	Red 17 , 0% to 100%	Fade	255
	87	87	000 - 255	Green 17 , 0% to 100%	Fade	255
	88	88	000 - 255	Blue 17 , 0% to 100%	Fade	255
	89	89	000 - 255	White 17 , 0% to 100%	Fade	255
	90	90	000 - 255	Red 18 , 0% to 100%	Fade	255

CONTINUED ON NEXT PAGE

DMX TRAITS

CHANNEL			DMX VALUES	FUNCTION	FADE STATUS	DEFAULT VALUE
STANDARD	PIXELS	EXTENDED				
	91	91	000 - 255	Green 18 , 0% to 100%	Fade	255
	92	92	000 - 255	Blue 18 , 0% to 100%	Fade	255
	93	93	000 - 255	White 18 , 0% to 100%	Fade	255
	94	94	000 - 255	Red 19 , 0% to 100%	Fade	255
	95	95	000 - 255	Green 19 , 0% to 100%	Fade	255
	96	96	000 - 255	Blue 19 , 0% to 100%	Fade	255
	97	97	000 - 255	White 19 , 0% to 100%	Fade	255
24	98	98		Spark LED Strobe	Snap	50
			000 - 031	Shutter Closed		
			032 - 063	Shutter Open		
			064 - 095	Strobe, slow to fast		
			096 - 127	Fast Close, Slow Open		
			128 - 159	Fast Open, Slow Close		
			160 - 191	Pulse Effects		
			192 - 222	Random Strobe All, slow to fast		
			223 - 254	Random Strobe Pixels, slow to fast		
255	Sync Dim and Strobe with Main					
25	99	99	000 - 255	Spark LED Dimmer , 0% to 100%	Fade	0
	100	100	000 - 255	Spark LED Dimmer Fine	Fade	0
		101	000 - 255	Spark LED Dimmer 1 , 0% to 100%	Fade	255
		102	000 - 255	Spark LED Dimmer 2 , 0% to 100%	Fade	255
		103	000 - 255	Spark LED Dimmer 3 , 0% to 100%	Fade	255
		104	000 - 255	Spark LED Dimmer 4 , 0% to 100%	Fade	255
		105	000 - 255	Spark LED Dimmer 5 , 0% to 100%	Fade	255
		106	000 - 255	Spark LED Dimmer 6 , 0% to 100%	Fade	255
		107	000 - 255	Spark LED Dimmer 7 , 0% to 100%	Fade	255
		108	000 - 255	Spark LED Dimmer 8 , 0% to 100%	Fade	255
		109	000 - 255	Spark LED Dimmer 9 , 0% to 100%	Fade	255
		110	000 - 255	Spark LED Dimmer 10 , 0% to 100%	Fade	255
		111	000 - 255	Spark LED Dimmer 11 , 0% to 100%	Fade	255
		112	000 - 255	Spark LED Dimmer 12 , 0% to 100%	Fade	255
		113	000 - 255	Spark LED Dimmer 13 , 0% to 100%	Fade	255
		114	000 - 255	Spark LED Dimmer 14 , 0% to 100%	Fade	255
		115	000 - 255	Spark LED Dimmer 15 , 0% to 100%	Fade	255
		116	000 - 255	Spark LED Dimmer 16 , 0% to 100%	Fade	255
		117	000 - 255	Spark LED Dimmer 17 , 0% to 100%	Fade	255
		118	000 - 255	Spark LED Dimmer 18 , 0% to 100%	Fade	255
		119	000 - 255	Spark LED Dimmer 19 , 0% to 100%	Fade	255
		120	000 - 255	Spark LED Dimmer 20 , 0% to 100%	Fade	255
		121	000 - 255	Spark LED Dimmer 21 , 0% to 100%	Fade	255
		122	000 - 255	Spark LED Dimmer 22 , 0% to 100%	Fade	255

CONTINUED ON NEXT PAGE

DMX TRAITS

CHANNEL			DMX VALUES	FUNCTION	FADE STATUS	DEFAULT VALUE
STANDARD	PIXELS	EXTENDED				
		123	000 - 255	Spark LED Dimmer 23, 0% to 100%	Fade	255
		124	000 - 255	Spark LED Dimmer 24, 0% to 100%	Fade	255
		125	000 - 255	Spark LED Dimmer 25, 0% to 100%	Fade	255
		126	000 - 255	Spark LED Dimmer 26, 0% to 100%	Fade	255
		127	000 - 255	Spark LED Dimmer 27, 0% to 100%	Fade	255
		128	000 - 255	Spark LED Dimmer 28, 0% to 100%	Fade	255
		129	000 - 255	Spark LED Dimmer 29, 0% to 100%	Fade	255
		130	000 - 255	Spark LED Dimmer 30, 0% to 100%	Fade	255
		131	000 - 255	Spark LED Dimmer 31, 0% to 100%	Fade	255
		132	000 - 255	Spark LED Dimmer 32, 0% to 100%	Fade	255
		133	000 - 255	Spark LED Dimmer 33, 0% to 100%	Fade	255
		134	000 - 255	Spark LED Dimmer 34, 0% to 100%	Fade	255
		135	000 - 255	Spark LED Dimmer 35, 0% to 100%	Fade	255
		136	000 - 255	Spark LED Dimmer 36, 0% to 100%	Fade	255
		137	000 - 255	Spark LED Dimmer 37, 0% to 100%	Fade	255
		138	000 - 255	Spark LED Dimmer 38, 0% to 100%	Fade	255
		139	000 - 255	Spark LED Dimmer 39, 0% to 100%	Fade	255
		140	000 - 255	Spark LED Dimmer 40, 0% to 100%	Fade	255
		141	000 - 255	Spark LED Dimmer 41, 0% to 100%	Fade	255
		142	000 - 255	Spark LED Dimmer 42, 0% to 100%	Fade	255
		143	000 - 255	Spark LED Dimmer 43, 0% to 100%	Fade	255
		144	000 - 255	Spark LED Dimmer 44, 0% to 100%	Fade	255
		145	000 - 255	Spark LED Dimmer 45, 0% to 100%	Fade	255
		146	000 - 255	Spark LED Dimmer 46, 0% to 100%	Fade	255
		147	000 - 255	Spark LED Dimmer 47, 0% to 100%	Fade	255
		148	000 - 255	Spark LED Dimmer 48, 0% to 100%	Fade	255
		149	000 - 255	Spark LED Dimmer 49, 0% to 100%	Fade	255
		150	000 - 255	Spark LED Dimmer 50, 0% to 100%	Fade	255
		151	000 - 255	Spark LED Dimmer 51, 0% to 100%	Fade	255
		152	000 - 255	Spark LED Dimmer 52, 0% to 100%	Fade	255
		153	000 - 255	Spark LED Dimmer 53, 0% to 100%	Fade	255
		154	000 - 255	Spark LED Dimmer 54, 0% to 100%	Fade	255
		155	000 - 255	Spark LED Dimmer 55, 0% to 100%	Fade	255
		156	000 - 255	Spark LED Dimmer 56, 0% to 100%	Fade	255
		157	000 - 255	Spark LED Dimmer 57, 0% to 100%	Fade	255
		158	000 - 255	Spark LED Dimmer 58, 0% to 100%	Fade	255
		159	000 - 255	Spark LED Dimmer 59, 0% to 100%	Fade	255
		160	000 - 255	Spark LED Dimmer 60, 0% to 100%	Fade	255
		161	000 - 255	Spark LED Dimmer 61, 0% to 100%	Fade	255
		162	000 - 255	Spark LED Dimmer 62, 0% to 100%	Fade	255
		163	000 - 255	Spark LED Dimmer 63, 0% to 100%	Fade	255

CONTINUED ON NEXT PAGE

DMX TRAITS

CHANNEL			DMX VALUES	FUNCTION	FADE STATUS	DEFAULT VALUE
STANDARD	PIXELS	EXTENDED				
		164	000 - 255	Spark LED Dimmer 64 , 0% to 100%	Fade	255
		165	000 - 255	Spark LED Dimmer 65 , 0% to 100%	Fade	255
		166	000 - 255	Spark LED Dimmer 66 , 0% to 100%	Fade	255
		167	000 - 255	Spark LED Dimmer 67 , 0% to 100%	Fade	255
		168	000 - 255	Spark LED Dimmer 68 , 0% to 100%	Fade	255
		169	000 - 255	Spark LED Dimmer 69 , 0% to 100%	Fade	255
		170	000 - 255	Spark LED Dimmer 70 , 0% to 100%	Fade	255
		171	000 - 255	Spark LED Dimmer 71 , 0% to 100%	Fade	255
		172	000 - 255	Spark LED Dimmer 72 , 0% to 100%	Fade	255
		173	000 - 255	Spark LED Dimmer 73 , 0% to 100%	Fade	255
		174	000 - 255	Spark LED Dimmer 74 , 0% to 100%	Fade	255
		175	000 - 255	Spark LED Dimmer 75 , 0% to 100%	Fade	255
		176	000 - 255	Spark LED Dimmer 76 , 0% to 100%	Fade	255

FX GENERATOR GUIDELINES

Selection and control of the integrated FX on the Proteus RAYzor 1960 is found in the Main Fixture section. All FX are available, even in the DMX control modes with the lowest channel count. For your convenience, these functions are summarized below. Please refer to the **DMX Traits** section of this manual for detailed information.

DMX VALUES	FUNCTION
000 - 255	RGBW FX (see RGBW Pixel FX Table section of this manual)
	RGBW FX Speed
000 - 126	Reverse, fast to slow
127 - 128	Stop
129 - 255	Forward, slow to fast
000 - 255	Spark LED FX (see Spark LED FX Table section of this manual)
	Spark LED FX Speed
000 - 126	Reverse, fast to slow
127 - 128	Stop
129 - 255	Forward, slow to fast

FX for RGBW and Spark LED contain a selection channel to recall the desired pattern. The pattern direction and speed is then adjusted using the associated Speed channels. FX can run in forward or reverse, and can also be frozen at any time by using "Stop". The FX tables show the available patterns which are grouped for easier browsing. The first 10 DMX steps of the FX channel are used to change the type of curve for smooth or stepped FX. Once a curve is selected, it will be used for all FX recalled afterwards. When programming cues for fixtures, the user must make sure to change the curve first before selecting the pattern. The fixture defaults to the Sinewave pattern after every power cycle. See the **Waveforms** section of this manual for the available waveforms.

RGBW PIXEL FX TABLE

FX TYPE	SLOT	DMX	FX NAME	FX ADJUSTMENT	NOTES
Off		000	Off		
Waveform	1	001	Sinewave - Cross (default)		In and out fade start at the same time
	2	002	Sinewave - Full		In fade completes, then out fade completes
	3	003	Sawtooth - Cross		In and out fade start at the same time
	4	004	Sawtooth - Full		In fade complete, then out fade completes
	5	005	Ramp Up		
	6	006	Ramp Down		
	7	007	Steps		
	8-10	008 - 010	Not in use		
Intensity	11	011	Single	Reverse, Stop, Forward	1, 2, 3...19
	12	012	Single Bounce	Reverse, Stop, Forward	1, 2, 3...19, 18, 17, 16...1
	13	013	Snake	Reverse, Stop, Forward	1, 2, 3, 7, 12, 16, 19, 18, 17, 13, 8, 4, 5, 6, 11, 15, 14, 9, 10
	14	014	Snake Bounce	Reverse, Stop, Forward	Snake forward once and reverses
	15	015	Rows	Reverse, Stop, Forward	Row1, 2, 3, 4, 5
	16	016	Rows Bounce	Reverse, Stop, Forward	Rows forward once and reverses
	17	017	Column	Reverse, Stop, Forward	One column per step
	18	018	Column Bounce	Reverse, Stop, Forward	One column per step forward once and reverses
	19	019	Not in use		
	20	020	Slash	Reverse, Stop, Forward	1+4+8, 2+5+9+13, 3+6+10+14+17, 7+11+15+18, 12+16+19
	21	021	Backslash	Reverse, Stop, Forward	8+13+17, 4+9+14+18, 1+5+10+15+19, 2+6+11+16, 3+7+12
	22	022	Slash Back	Reverse, Stop, Forward	1+4+8, 2+5+9+13, 3+6+10+14+17, 7+11+15+18, 12+16+19, 8+13+17, 4+9+14+18, 1+5+10+15+19, 2+6+11+16, 3+7+12
	23	023	<>	Reverse, Stop, Forward	1+4+8+13+17, 3+7+12+16+19
	24	024	><	Reverse, Stop, Forward	1+5+10+14+17, 3+6+10+15+19
25	025	>>	Reverse, Stop, Forward	8, 4+9+13, 1+5+10+14+17, 2+6+11+15+18, 3+7+12+16+19	
26	026	<<	Reverse, Stop, Forward	12, 7+11+16, 3+6+10+15+19, 2+5+9+14+18, 1+4+8+13+17,	

CONTINUED ON NEXT PAGE

RGBW PIXEL FX TABLE

FX TYPE	SLOT	DMX	FX NAME	FX ADJUSTMENT	NOTES
Intensity (continued)	27	027	Rotating Bar	Reverse, Stop, Forward	8+9+10+11+12, 13+10+7, 17+14+10+6+3, 2+10+18, 1+5+10+15+19, 4+10+16
	28	028	Ring 1 Chase	Reverse, Stop, Forward	One pixel at a time in RGBW ring 1
	29	029	Ring 2 Chase	Reverse, Stop, Forward	One pixel at a time in RGBW ring 2
	30-37	030 - 037	Not in use		
	38	038	2 Pixels	Reverse, Stop, Forward	Any two random pixels per step
	39	039	3 Pixels	Reverse, Stop, Forward	Any three random pixels per step
	40	040	4 Pixels	Reverse, Stop, Forward	Any four random pixels per step
	41	041	1,2,3,4 Pixels	Reverse, Stop, Forward	Randomly pick 1, then 2, then 3, then 4 pixels
	42	042	Ring Build	Reverse, Stop, Forward	Builds ring 1, then ring 2, then ring 3, one pixel at a time
	43	043	Ring Build Erase	Reverse, Stop, Forward	Builds ring 1, then ring 2, then ring 3, one pixel at a time; then erases ring 1, then ring 2, then ring 3, one pixel at a time
	44	044	Ring Build Erase 2	Reverse, Stop, Forward	Builds ring 1, then ring 2, then ring 3, one pixel at a time; then erases ring 3, then ring 2, then ring 1, one pixel at a time
	45-56	045 - 056	Not in use		
	57	057	Alternate	Reverse, Stop, Forward	Evenly alternate (tick/tock/tick/tock) between RGBW pixel at full and Spark LEDs at full; keeps all colors, strobos, and intensities as set in DMX
	58	058	Burst Spark LED	Reverse, Stop, Forward	Toggles between RGBW Pixel at full (long) and Spark LEDs at full (short flash); keeps all colors, strobos, and intensities as set in DMX
	59	059	Strobe Alternate	Reverse, Stop, Forward	Strobos between RGBW Pixel at full (short, then off) and Spark LEDs at full (short, then off); keeps all colors, strobos, and intensities as set in DMX
	60	060	Lens/Spark LED Alterate	Reverse, Stop, Forward	Random Lens at full, then different Random Lens SparkLEDs at full; keeps all colors, strobos, and intensities as set in DMX
61-100	061 - 100	Not in use			

CONTINUED ON NEXT PAGE

RGBW PIXEL FX TABLE

FX TYPE	SLOT	DMX	FX NAME	FX ADJUSTMENT	NOTES
Static Patterns	101	101	Row 1	Disabled	
	102	102	Row 2	Disabled	
	103	103	Row 3	Disabled	
	104	104	Row 4	Disabled	
	105	105	Row 5	Disabled	
	106	106	Column 1	Disabled	
	107	107	Column 2	Disabled	
	108	108	Column 3	Disabled	
	109	109	Column 4	Disabled	
	110	110	Column 5	Disabled	
	111	111	Column 6	Disabled	
	112	112	Column 7	Disabled	
	113	113	Column 8	Disabled	
	114	114	Column 9	Disabled	
	115	115	Ring 1	Disabled	
	116	116	Ring 2	Disabled	
	117	117	Ring 3	Disabled	
	118	118	X	Disabled	1, 5, 10, 15, 19, 17, 14, 6, 3
	119	119	Slash	Disabled	1, 5, 10, 15, 19
	120	120	Backslash	Disabled	3, 6, 10, 14, 17
	121	121	Arrow Left	Disabled	1, 4, 8, 13, 17, 9, 10, 11, 12
	122	122	Arrow Right	Disabled	3, 7, 12, 16, 19, 8, 9, 10, 11
	123	123	<	Disabled	1, 2, 4, 5, 8, 9, 13, 14, 17, 18
	124	124	>	Disabled	2, 3, 6, 7, 11, 12, 15, 16, 18, 19
125-130	125 - 130	Not in use			
Color	131	131	RGBW Cells	Reverse, Stop, Forward	Every pixel randomly selects R, G, B, or W on each step
	132	132	RGBWCMY Cells	Reverse, Stop, Forward	Every pixel randomly selects R, G, B, W, C, M, or Y on each step
	133	133	Color Wheel Cells	Reverse, Stop, Forward	Every pixel randomly selects a color from the color wheel on each step
	134	134	RGBW Rows	Reverse, Stop, Forward	Every row randomly selects R, G, B, or W on each step
	135	135	RGBWCMY Rows	Reverse, Stop, Forward	Every row randomly selects R, G, B, W, C, M, or Y on each step
	136	136	Color Wheel Rows	Reverse, Stop, Forward	Every row randomly selects a color from the color wheel on each step
	137	137	RGBW Columns	Reverse, Stop, Forward	Every column randomly selects R, G, B, or W on each step
	138	138	RGBWCMY Columns	Reverse, Stop, Forward	Every column randomly selects R, G, B, W, C, M, or Y on each step
CONTINUED ON NEXT PAGE					

RGBW PIXEL FX TABLE

FX TYPE	SLOT	DMX	FX NAME	FX ADJUSTMENT	NOTES
Color (continued)	139	139	Color Wheel Columns	Reverse, Stop, Forward	Every column randomly selects a color from the color wheel on each step
	140	140	RGBW Single Row	Reverse, Stop, Forward	A single row randomly selects R, G, B or W on each step
	141	141	RGBWCMY Single Row	Reverse, Stop, Forward	A single row randomly select R, G, B, W, C, M, or Y on each step
	142	142	Color Wheel Single Row	Reverse, Stop, Forward	A single row randomly selects a color from the color wheel for each step
	143	143	RGBW Single Column	Reverse, Stop, Forward	A single column randomly selects R, G, B, or W on each step
	144	144	RGBWCMY Single Column	Reverse, Stop, Forward	A single column randomly selects R, G, B, W, C, M, or Y on each step
	145	145	Color Wheel Single Column	Reverse, Stop, Forward	A single column randomly selects a color from the color wheel on each step
	146	146	RGB Rows	Reverse, Stop, Forward	Red row 1, then 1,2, then 1,2,3, then 1,2,3,4, then 1,2,3,4,5; then Green replaces row 1, then 1,2, then 1,2,3, etc
	147	147	RGB Columns	Reverse, Stop, Forward	Columns fill from left to right in all red, then fill all green, then fill all blue
	148	148	Red White Cells	Reverse, Stop, Forward	Every cell randomly picks red or white on each step
	149	149	Green White Cells	Reverse, Stop, Forward	Every cell randomly picks green or white on each step
	150	150	Blue White Cells	Reverse, Stop, Forward	Every cell randomly picks blue or white on each step
	151	151	Red Green Cells	Reverse, Stop, Forward	Every cell randomly picks red or green on each step
	152	152	Red Blue Cells	Reverse, Stop, Forward	Every cell randomly picks red or blue on each step
	153	153	Blue Green Cells	Reverse, Stop, Forward	Every cell randomly picks blue or green on each step
	154	154	Ring - Mix to Color Wheel	Reverse, Stop, Forward	Two rings chase between mixed color and color wheel, from the center of the display moving outwards
	155	155	Random White Cell	Reverse, Stop, Forward	White at full randomly replaces the currently mixed color one cell at a time
	156	156	Random White Row	Reverse, Stop, Forward	White at full randomly replaces the currently mixed color one row at a time
	157	157	Random White Column	Reverse, Stop, Forward	White at full randomly replaced the currently mixed color one column at a time
	158	158	White Flash	Reverse, Stop, Forward	White at full flashes once over the currently mixed color on all cells
159	159	Red Flash	Reverse, Stop, Forward	Red at full flashes once over the currently mixed color on all cells	
160	160	Green Flash	Reverse, Stop, Forward	Green at full flashes once over the currently mixed color on all cells	

CONTINUED ON NEXT PAGE

RGBW PIXEL FX TABLE

FX TYPE	SLOT	DMX	FX NAME	FX ADJUSTMENT	NOTES
Color (continued)	161	161	Blue Flash	Reverse, Stop, Forward	Blue at full flashes once over the currently mixed color on all cells
	162	162	Color Wheel Flash	Reverse, Stop, Forward	Selected color wheel color at full flashes once over the currently mixed color on all cells
	163	163	Alternate Color	Reverse, Stop, Forward	Alternates between mixed color and color wheel color on all cells
	164- 255	164- 255	Not in use		

SPARK LED FX TABLE

FX TYPE	SLOT	DMX	FX NAME	FX ADJUSTMENT	NOTES
Off		000	Off		
Waveform	1	001	Sinewave - Cross (default)		In and out fade start at the same time
	2	002	Sinewave - Full		In fade complete, then out fade completes
	3	003	Sawtooth - Cross		In and out fade start at the same time
	4	004	Sawtooth - Full		In fade completes, then out fade completes
	5	005	Ramp Up		
	6	006	Ramp Down		
	7	007	Steps		
	8-10	008 - 010	No function		
Spark LED FX	11	011	Starfield	Reverse, Stop, Forward	Pixels switch on and off at random for random lengths of time
	12	012	1 Pixel	Reverse, Stop, Forward	Randomly lights 1 pixel per step
	13	013	2 Pixels	Reverse, Stop, Forward	Randomly lights 2 pixels per step
	14	014	3 Pixels	Reverse, Stop, Forward	Randomly lights 3 pixels per step
	15	015	4 Pixels	Reverse, Stop, Forward	Randomly lights 4 pixels per step
	16	016	5 Pixels	Reverse, Stop, Forward	Randomly lights 5 pixels per step
	17	017	10 Pixels	Reverse, Stop, Forward	Randomly lights 10 pixels per step
	18	018	19 Pixels	Reverse, Stop, Forward	Randomly lights 19 pixels per step
	19	019	38 Pixels	Reverse, Stop, Forward	Randomly lights 38 pixels per step
	20	020	Single Row	Reverse, Stop, Forward	Lights a single row per step
	21	021	3 Rows	Reverse, Stop, Forward	Lights 3 rows per step
	22	022	Single Column	Reverse, Stop, Forward	Lights a single column per step
	23	023	3 Column	Reverse, Stop, Forward	Lights 3 columns per step
	24	024	Pixel Ring Chase	Reverse, Stop, Forward	Within each RGBW pixel, the individual Spark LEDs illuminate one at a time in ring order (e.g. in Pixel 1: Spark LEDs 1, 5, 11, 4)
	25	025	Pixel Row Chase	Reverse, Stop, Forward	Within each RGBW pixel, the individual Spark LEDs illuminate in row order (e.g. in Pixel 1: Spark LEDs 1, 5+4, 11)
CONTINUED ON NEXT PAGE					

SPARK LED FX TABLE

FX TYPE	SLOT	DMX	FX NAME	FX ADJUSTMENT	NOTES
Spark LED FX (continued)	26	026	Pixel Ring Chase 2	Reverse, Stop, Forward	Within each RGBW pixel, one Spark LED illuminates in ring order in each step
	27	027	Center Out	Reverse, Stop, Forward	Turns on all Spark LEDs in lens 10, then steps from the center outwards one ring at a time
	28	028	Fireworks	Reverse, Stop, Forward	Strobes rapidly while randomly filling Spark LEDs from the center outwards, then randomly switching Spark LEDs off from the center outwards
	29	029	Ring	Reverse, Stop, Forward	Single pixels in the order: ring 1, ring 2, ring 3
	30	030	Row	Reverse, Stop, Forward	Single pixels in the order: row 1, 2, 3, 4, 5, 6, 7
	31	031	Snake	Reverse, Stop, Forward	Single pixels in row 1, left to right; row 2, right to left; row 3, left to right; row 4 right to left; row 5, left to right; row 6, right to left; row 7, left to right
	32-100	032 - 100	No function		
Full Lens Patterns	101	101	Single	Reverse, Stop, Forward	1, 2, 3...19
	102	102	Single Bounce	Reverse, Stop, Forward	1, 2, 3...19, 18, 17, 16...1
	103	103	Snake	Reverse, Stop, Forward	1, 2, 3, 7, 12, 16, 19, 18, 17, 13, 8, 4, 5, 6, 11, 15, 14, 9, 10
	104	104	Snake Bounce	Reverse, Stop, Forward	Snake forward once and reverses
	105	105	Rows	Reverse, Stop, Forward	Row 1, 2, 3, 4, 5
	106	106	Rows Bounce	Reverse, Stop, Forward	Rows forward once and reverses
	107	107	Column	Reverse, Stop, Forward	One column per step
	108	108	Column Bounce	Reverse, Stop, Forward	One column per step forward once, then runs in reverse
	109	109	Not in use		
	110	110	Slash	Reverse, Stop, Forward	1+4+8, 2+5+9+13, 3+6+10+14+17, 7+11+15+18, 12+16+19
	111	111	Backslash	Reverse, Stop, Forward	8+13+17, 4+9+14+18, 1+5+10+15+19, 2+6+11+16, 3+7+12
	112	112	Slash Back	Reverse, Stop, Forward	1+4+8, 2+5+9+13, 3+6+10+14+17, 7+11+15+18, 12+16+19, 8+13+17, 4+9+14+18, 1+5+10+15+19, 2+6+11+16, 3+7+12
	113	113	<>	Reverse, Stop, Forward	1+4+8+13+17, 3+7+12+16+19
CONTINUED ON NEXT PAGE					

SPARK LED FX TABLE

FX TYPE	SLOT	DMX	FX NAME	FX ADJUSTMENT	NOTES
Full Lens Patterns (continued)	114	114	><	Reverse, Stop, Forward	1+5+10+14+17, 3+6+10+15+19
	115	115	>>	Reverse, Stop, Forward	8, 4+9+13, 1+5+10+14+17, 2+6+11+15+18, 3+7+12+16+19
	116	116	<<	Reverse, Stop, Forward	12, 7+11+16, 3+6+10+15+19, 2+5+9+14+18, 1+4+8+13+17
	117	117	Rotating Bar	Reverse, Stop, Forward	8+9+10+11+12, 13+10+7, 17+14+10+6+3, 2+10+18, 1+5+10+15+19, 4+10+16
	118	118	Ring 1 Chase	Reverse, Stop, Forward	One pixel at a time in RGBW Ring 1
	119	119	Ring 2 Chase	Reverse, Stop, Forward	One pixel at a time in RGBW Ring 2
	120-127	120 - 127	No function		
	128	128	2 Pixels	Reverse, Stop, Forward	Turn on any 2 random pixels per step
	129	129	3 Pixels	Reverse, Stop, Forward	Turn on any 3 random pixels per step
	130	130	4 Pixels	Reverse, Stop, Forward	Turn on any 4 random pixels per step
	131	131	1, 2, 3, 4 Pixels	Reverse, Stop, Forward	For the first step turn on any 1 random pixel; then 2 random pixels for the next step; then 3 random pixels; then 4 random pixels
	132	132	Ring Build	Reverse, Stop, Forward	Adds one pixel per step in Ring 1, then Ring 2, then Ring 3
	133	133	Ring Build Erase	Reverse, Stop, Forward	Adds one pixel per step in Ring 1, then Ring 2, then Ring 3; then erases 1 pixel per step in Ring 1, then Ring 2, then Ring 3
	134	134	Ring Build Erase 2	Reverse, Stop, Forward	Adds one pixel per step in Ring 1, then Ring 2, then Ring 3; then erases 1 pixel per step in Ring 3, then Ring 2, then Ring 1
	135-200	135 - 200	No function		
Full Lens Static Patterns	201	201	Lens Row 1	Disabled	All Spark LEDs in RGBW row 1
	202	202	Lens Row 2	Disabled	All Spark LEDs in RGBW row 2
	203	203	Lens Row 3	Disabled	All Spark LEDs in RGBW row 3
	204	204	Lens Row 4	Disabled	All Spark LEDs in RGBW row 4
	205	205	Lens Row 5	Disabled	All Spark LEDs in RGBW row 5
	206	206	Lens Column 1	Disabled	All Spark LEDs in RGBW column 1
	207	207	Lens Column 2	Disabled	All Spark LEDs in RGBW column 2
	208	208	Lens Column 3	Disabled	All Spark LEDs in RGBW column 3
	209	209	Lens Column 4	Disabled	All Spark LEDs in RGBW column 4
	210	210	Lens Column 5	Disabled	All Spark LEDs in RGBW column 5

CONTINUED ON NEXT PAGE

SPARK LED FX TABLE

FX TYPE	SLOT	DMX	FX NAME	FX ADJUSTMENT	FUNCTION
Full Lens Static Patterns (continued)	211	211	Lens Column 6	Disabled	All Spark LEDs in RGBW column 6
	212	212	Lens Column 7	Disabled	All Spark LEDs in RGBW column 7
	213	213	Lens Column 8	Disabled	All Spark LEDs in RGBW column 8
	214	214	Lens Column 9	Disabled	All Spark LEDs in RGBW column 9
	215	215	Ring 1	Disabled	All Spark LEDs in RGBW ring 1
	216	216	Ring 2	Disabled	All Spark LEDs in RGBW ring 2
	217	217	Ring 3	Disabled	All Spark LEDs in RGBW ring 3
	218	218	X	Disabled	All Spark LEDs in lens 1, 5, 10, 15, 19, 17, 14, 6, 3
	219	219	Slash	Disabled	All Spark LEDs in lens 1, 5, 10, 15, 19
	220	220	Backslash	Disabled	All Spark LEDs in lens 3, 6, 10, 14, 17
	221	221	Arrow Left	Disabled	All Spark LEDs in lens 1, 4, 8, 13, 17, 9, 10, 11, 12
	222	222	Arrow Right	Disabled	All Spark LEDs in lens 3, 7, 12, 16, 19, 8, 9, 10, 11
	223	223	<	Disabled	All Spark LEDs in lens 1, 2, 4, 5, 8, 9, 13, 14, 17, 18
	224	224	>	Disabled	All Spark LEDs in lens 2, 3, 6, 7, 11, 12, 15, 16, 18, 19
	225-230	225 - 230	No function		
Spark LED Pattern	231	231	Row 1	Disabled	
	232	232	Row 2	Disabled	
	233	233	Row 3	Disabled	
	234	234	Row 4	Disabled	
	235	235	Row 5	Disabled	
	236	236	Row 6	Disabled	
	237	237	Row 7	Disabled	
	238	238	Row 8	Disabled	
	239	239	Row 9	Disabled	
	240	240	Row 10	Disabled	
	241	241	Row 11	Disabled	
	242	242	Ring 1	Disabled	
	243	243	Ring 2	Disabled	
	244	244	Ring 3	Disabled	
	245	245	Ring 4	Disabled	
246	246	Ring 5	Disabled		
247-255	247 - 255	No function			

WAVEFORMS

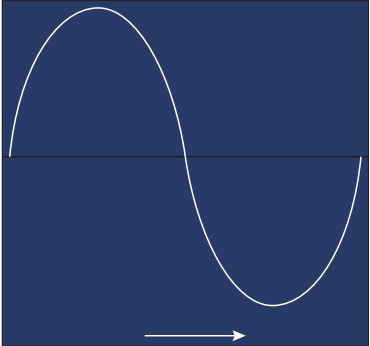
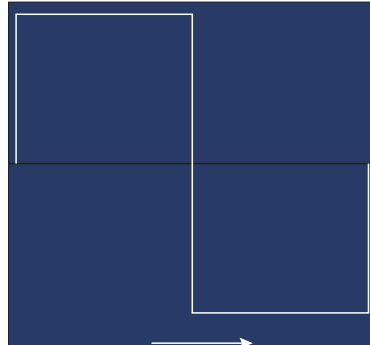
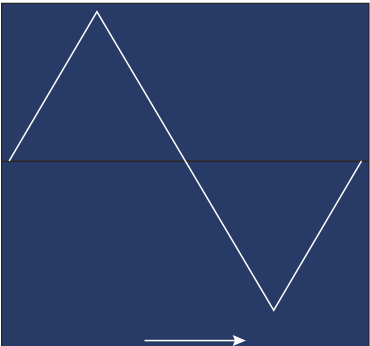
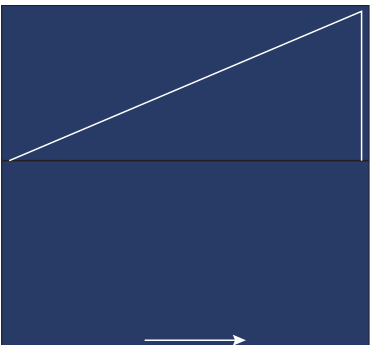
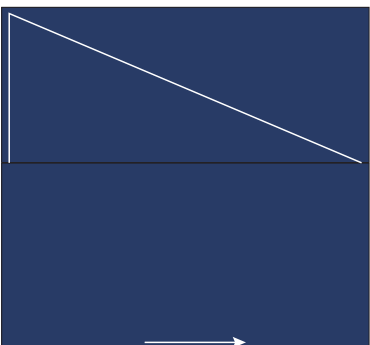
Sinewave	 A diagram of a sinewave waveform. The wave is a smooth, continuous curve that oscillates above and below a central horizontal axis. A small white arrow at the bottom of the plot points to the right, indicating the direction of time.
Step	 A diagram of a step waveform. The signal starts at a low level, then abruptly jumps to a higher level and remains constant for a period. It then drops abruptly back to the low level and remains constant again. A small white arrow at the bottom of the plot points to the right.
Sawtooth	 A diagram of a sawtooth waveform. The signal increases linearly from a low level to a high level, then drops sharply back to the low level, and begins increasing again. A small white arrow at the bottom of the plot points to the right.
Ramp Up	 A diagram of a ramp up waveform. The signal increases linearly from a low level to a high level over the entire duration of the plot. A small white arrow at the bottom of the plot points to the right.
Ramp Down	 A diagram of a ramp down waveform. The signal decreases linearly from a high level to a low level over the entire duration of the plot. A small white arrow at the bottom of the plot points to the right.

DIMMER CURVES

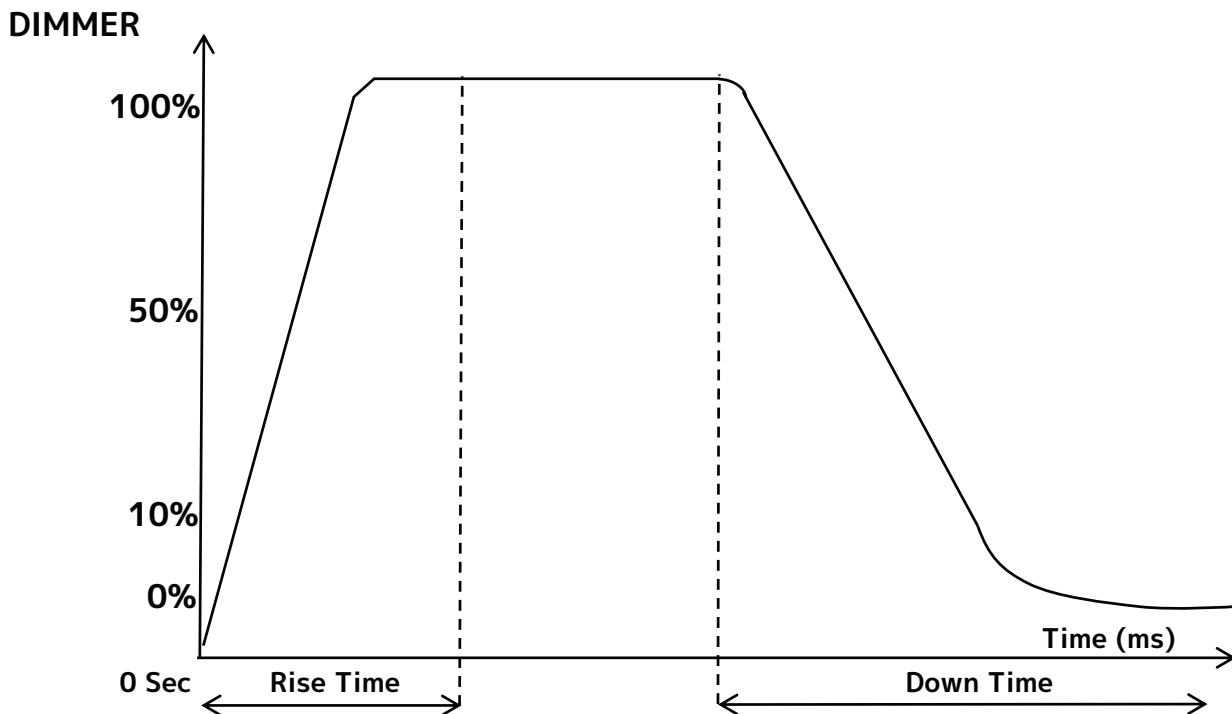

Dimming Curve Ramp Effect	0 sec Fade Time		1 sec Fade Time	
	Rise Time (ms)	Down Time (ms)	Rise Time (ms)	Down Time (ms)
Standard (default)	0	0	0	0
Stage	780	1100	1540	1660
TV	1180	1520	1860	1940
Architectural	1380	1730	2040	2120
Theatre	1580	1940	2230	2280
Stage 2	0	1100	0	1660

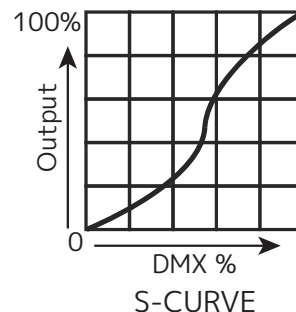
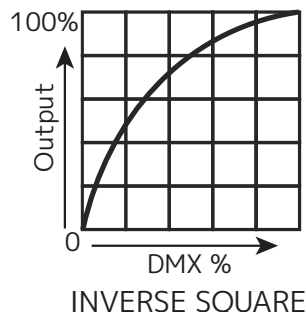
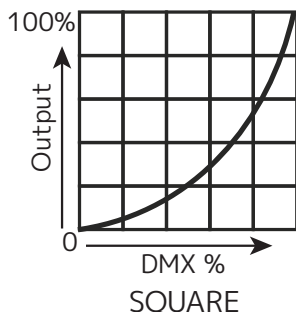
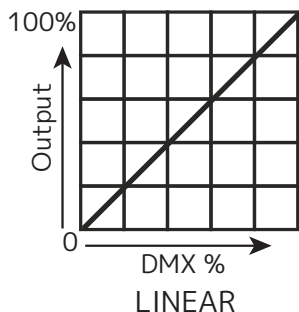

COLOR TEMPERATURE TABLE

COLOR TEMPERATURE (K)	DMX VALUE
2000	011
2050	012
2100	013
2150	014
2200	015
2250	016
2300	017
2350	018
2400	019
2450	020
2500	021
2550	022
2600	023
2650	024
2700	025
2750	026
2800	027
2850	028
2900	029
2950	030
3000	031
3050	032
3100	033
3150	034
3200	035
3250	036
3300	037
3350	038
3400	039
3450	040
3500	041
3550	042
3600	043
3650	044
3700	045
3750	046
3800	047
3850	048
3900	049
3950	050
4000	051
4050	052
4100	053

COLOR TEMPERATURE (K)	DMX VALUE
4150	054
4200	055
4250	056
4300	057
4350	058
4400	059
4450	060
4500	061
4550	062
4600	063
4650	064
4700	065
4750	066
4800	067
4850	068
4900	069
4950	070
5000	071
5050	072
5100	073
5150	074
5200	075
5250	076
5300	077
5350	078
5400	079
5450	080
5500	081
5550	082
5600	083
5650	084
5700	085
5750	086
5800	087
5850	088
5900	089
5950	090
6000	091
6050	092
6100	093
6150	094
6200	095
6250	096

COLOR TEMPERATURE TABLE

COLOR TEMPERATURE (K)	DMX VALUE
6300	097
6350	098
6400	099
6450	100
6500	101
6550	102
6600	103
6650	104
6700	105
6750	106
6800	107
6850	108
6900	109
6950	110
7000	111
7050	112
7100	113
7150	114
7200	115
7250	116
7300	117
7350	118
7400	119
7450	120
7500	121
7550	122
7600	123
7650	124
7700	125
7750	126
7800	127
7850	128
7900	129
7950	130
8000	131
8050	132
8100	133
8150	134
8200	135
8250	136
8300	137
8350	138
8400	139

COLOR TEMPERATURE (K)	DMX VALUE
8450	140
8500	141
8550	142
8600	143
8650	144
8700	145
8750	146
8800	147
8850	148
8900	149
8950	150
9000	151
9050	152
9100	153
9150	154
9200	155
9250	156
9300	157
9350	158
9400	159
9450	160
9500	161
9550	162
9600	163
9650	164
9700	165
9750	166
9800	167
9850	168
9900	169
9950	170
10000	171

PRIMARY-SECONDARY SET UP

This function allows you to link units together to run in a Primary-Secondary set-up, in which one unit will act as the controlling unit and the others will react to the controlling unit's built-in programs. Any unit can be configured to act as a Primary or as a Secondary, but only one unit in a given system can be programmed to act as the Primary.

PRIMARY-SECONDARY CONNECTIONS AND SETTINGS:

1. Daisy chain your units via the XLR connectors on the rear panels of each unit. Use standard XLR data cables to link your units together. Remember that the male XLR connector is the input and the female XLR connector is the output. The first unit in the chain (primary) will use the female XLR connector only, while the last unit in the chain will use the male XLR connector only.
2. On the primary unit, use the display screen and control panel to navigate to Function > Auto Program, then use scroll to "Primary" and press ENTER.
3. On the secondary unit(s), use the display screen and control panel to navigate to Function > Secondary Mode, and select one of the three available secondary groupings. Please refer to the **Record Controller** section of this manual for more information regarding secondary mode groupings.
4. Repeat Step 3 for each secondary unit in the system. Make sure that only one unit is designated as the Primary, while all other units are designated as Secondaries.
5. The secondary units will now follow the behavior of the primary unit.

ERROR CODES

When the unit is powered on, it will automatically enter a "Reset/Test" mode, which brings all the internal motors to a home position. If an internal problem with one or more of the motors is detected, an error code will flash in the display in the form of "XXEr" where XX will represent a code associated with the detected error. These codes are listed in the table below.

For example, when the display shows "PAN Er" it means there is some type of error with the Pan motor. If there are multiple errors during the start-up process, they will all flash in the display. For example: if the fixtures has errors related to pan, tilt, and zoom all at the same time, you will see the error message "PAN Er", "TILT Er", and "Zoom Er" flash and repeat 5 times.

If an error is detected during the initial start-up procedure, the fixture will self-generate a second reset signal and try to realign all the motors and correct the errors. If the error persists after a second attempt, a third attempt will be made. If after a third attempt all the errors have not been corrected the fixture will make the following determinations:

- **3 or More Errors:** The fixture cannot function properly with three or more errors, and therefore the fixture will place itself in stand-by mode until subsequent repairs can be made.
- **Less Than 3 Errors:** The fixture has less than 3 errors. Most other functions will work properly. The fixture will attempt to operate normally until the errors can be corrected by a technician. The errors in question will remain flashing in the display as a reminder of internal errors.

ERROR CODES	
Error codes are subject to change without any prior written notice.	
ERROR CODE	DESCRIPTION
PAN Er	Movement is not located in the default position after the reset. This message will appear after a fixture reset if the magnetic-indexing circuit malfunctions (sensor failed, or magnet is missing) or there is a motor failure (defective motor or a defective motor IC drive on the main PCB). This error may also be displayed if the head/yoke was blocked during TILT Er a reset function.
TILT Er	
Zoom Er	Movement is not located in the default position after the reset. This message will appear after a fixture reset if the magnetic-indexing circuit malfunctions (sensor failed, or magnet is missing) or there is a motor failure (defective motor or a defective motor IC drive on the main PCB).

SOFTWARE UPDATE



**ONLY QUALIFIED TECHNICIANS SHOULD PERFORM THIS FUNCTION!
NOTE ALL MENU SETTINGS BEFORE UPDATING SOFTWARE!
FIXTURE SOFTWARE CAN NOT BE DOWNGRADED!
DOWNLOAD FIXTURE SOFTWARE TO PC ONLY! (NO MAC SUPPORT)
PLEASE CONTACT ELATION SERVICE FOR FURTHER INFORMATION.**

An Elation E-Loader III can be used to update the fixture to the latest software. Please visit the E-Loader III product page at the Elation web site and download the product manual for step by step instructions.

<https://www.elationlighting.com/e-loader-iii-software-uploader>

To order the E-Loader III uploader and the updated software for your fixture, please contact Elation support for details.

DIMENSIONAL DRAWINGS

FIXTURE

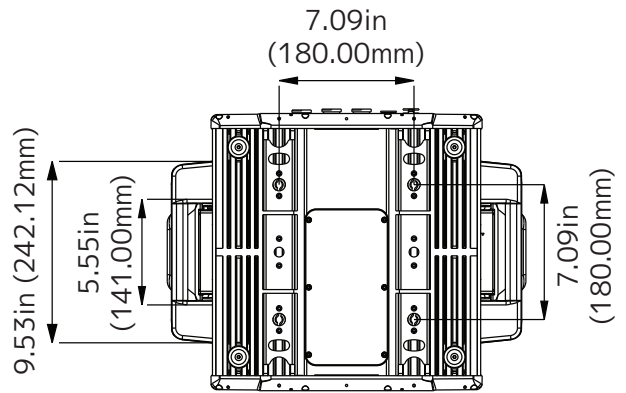
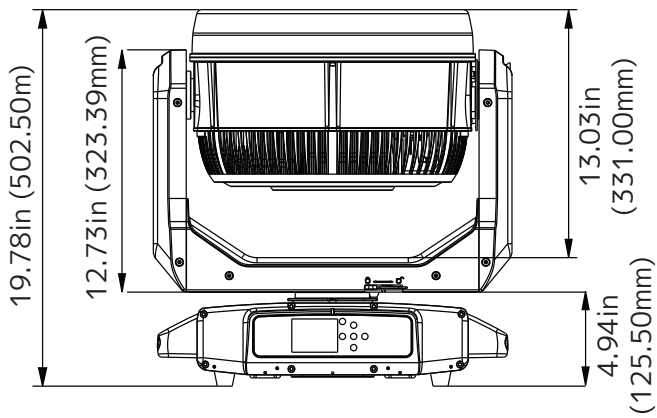
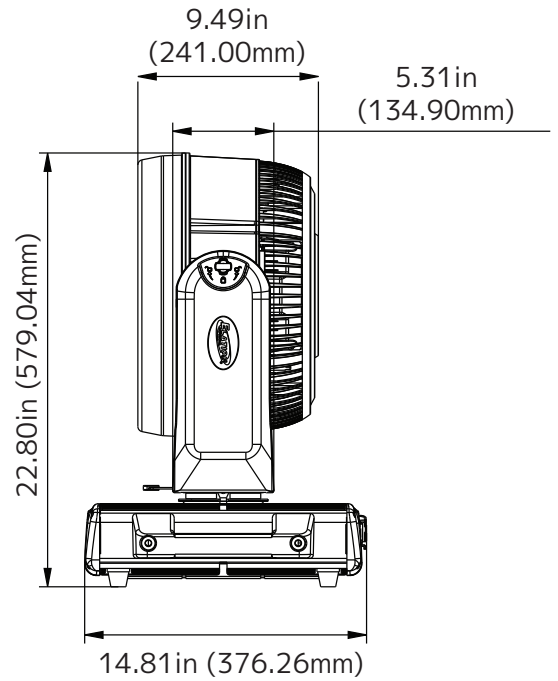
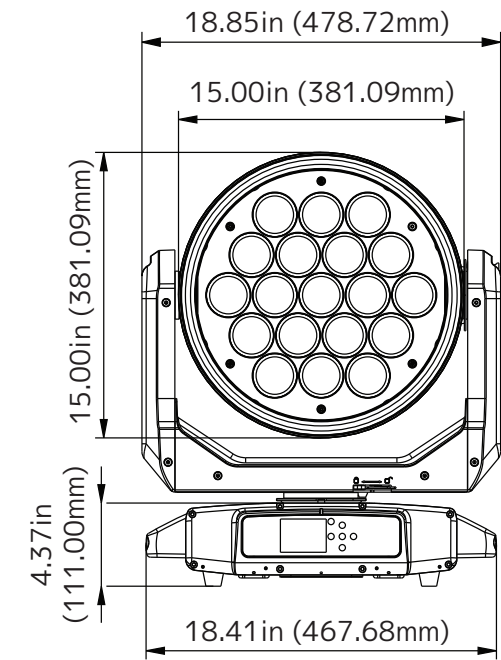

Drawings not shown to scale.

DIMENSIONAL DRAWINGS

FOAM IN-LAY

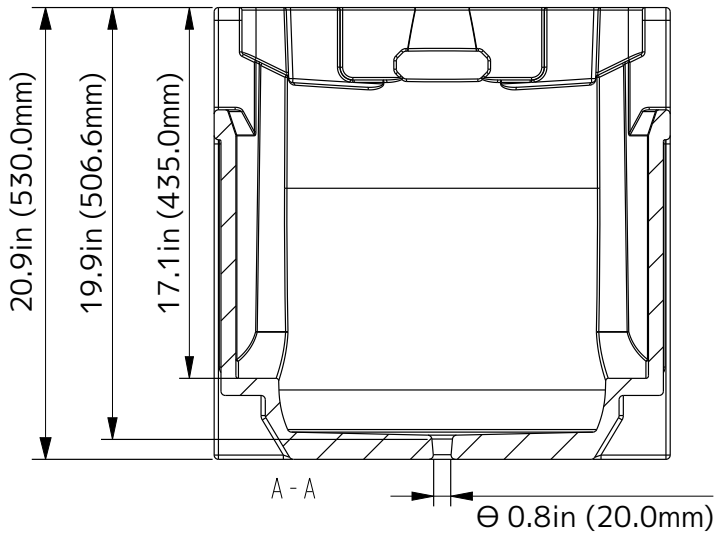
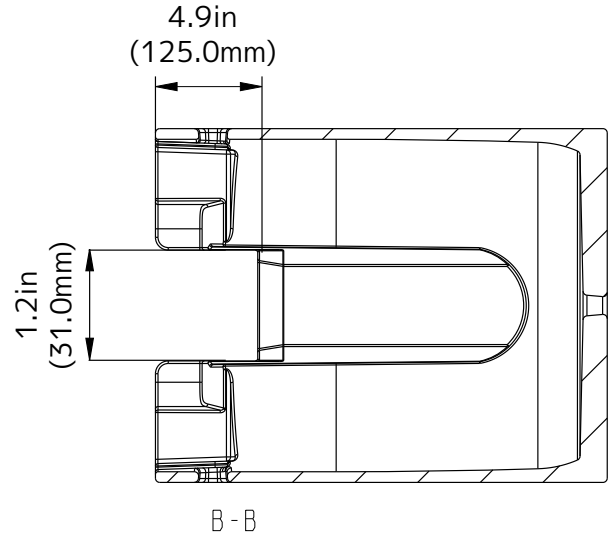
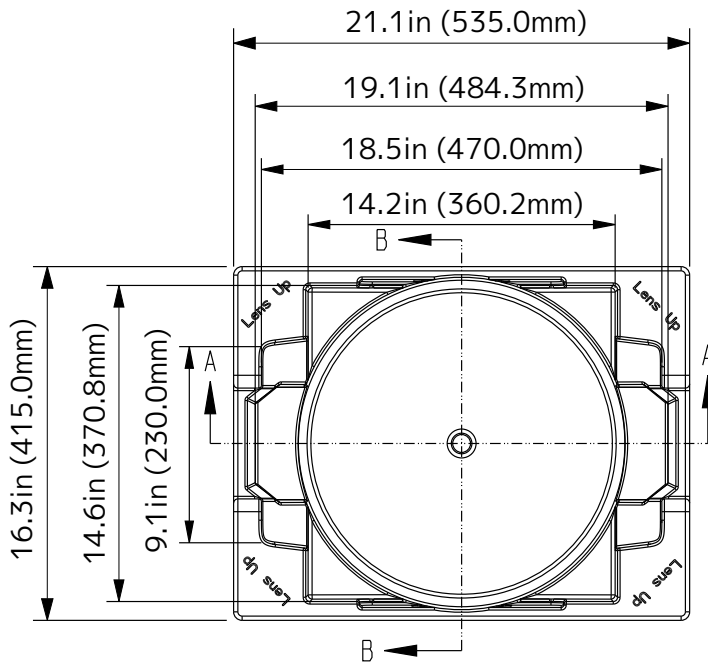

Drawings not shown to scale.

SPECIFICATIONS

SOURCE

(19) 60W Osram RGBW LEDs

(76) 2W White SparkLED™

50,000 Hour Average LED Life*

*Test lab conditions. May vary depending on several factors including but not limited to:
Environmental Conditions, Power/Voltage, Usage Patterns (On-Off Cycling), Control, and Dimming.

PHOTOMETRIC DATA

18.100 Total Lumen Output

CRI 80

Zoom Range 5° - 55°

Beam Angle 5.6° - 53.6°

Field Angle 7.8° - 71.1°

EFFECTS

Motorized Zoom

Linear Color Temperature Presets (2700-8000K)

RGBW Color Mixing and Pixel Control

White SparkLED Lens Effect

Color Presets and Macros

Electronic Strobe and Variable Dimming Curves

16-bit Dimming

Pan Angle: 360° (continuous rotation) / 540°

Tilt Angle: 360° (continuous rotation) / 270°

CONTROL / CONNECTIONS

3 DMX Channel Modes (25 / 100 / 176 channels)

360° Continuous Pan and Tilt Movement

DMX Adjustable Refresh Rate (900 -25000 Hz)

(6) Button Touch Panel

Full Color 180° Reversible LCD Menu Display

RDM Support

IP65 5pin XLR DMX In/Out

IP65 RJ45 Ethernet In/Out (Art-Net, sACN)

IP65 Locking Power Cable In

SIZE / WEIGHT

Length: 14.81 in (376.26mm)

Width: 18.41 in (467.68mm)

Height: 22.80 in (579.04mm)

Weight: 73.0 lbs. (33.1kg)

ELECTRICAL / THERMAL

AC 100-240V 50/60Hz

1600W Max Power Consumption

Ambient Temperature Range: -4°F to 113°F (-20°C to 45°C)

APPROVALS / RATINGS

CE | cETLus | IP65 | UKCA



IP65

FCC STATEMENT

This device complies with Part 15 of the FCC rules. Operation is subject to the following two conditions: (1) this device may not cause harmful interference, and (2) this device must accept any interference received, including interference that may cause undesired operation.

FCC RADIO FREQUENCY INTERFERENCE WARNINGS & INSTRUCTIONS

This equipment has been tested and found to comply with the limits for a class B digital device, pursuant to part 15 of the FCC Rules. These limits are designed to provide reasonable protection against harmful interference in a residential installation. This device uses and can radiate radio frequency energy, and if not installed and used in accordance with the included instructions, may cause harmful interference to radio communications. However, there is no guarantee that interference will not occur in a particular installation. If this device does cause harmful interference to radio or television reception, which can be determined by turning the device off and on, the user is encouraged to try to correct the interference by one or more of the following methods:

- Reorient or relocate that device.
- Increase the separation between the device and the receiver.
- Connect the device and the radio receiver to electrical outlets on separate circuits.
- Consult the dealer or an experienced radio/TV technician for help.

Please note that the changes or modifications of this product that are not expressly approved by the party responsible for compliance could void the user's authority to operate the equipment.



This page intentionally left blank.

