



PROTEUS[™] MAXIMUS MAXIMUS WMG

user manual

©2024 ELATION PROFESSIONAL all rights reserved. Information, specifications, diagrams, images, and instructions herein are subject to change without notice. ELATION PROFESSIONAL logo and identifying product names and numbers herein are trademarks of ELATION PROFESSIONAL. Copyright protection claimed includes all forms and matters of copyrightable materials and information now allowed by statutory or judicial law or hereinafter granted. Product names used in this document may be trademarks or registered trademarks of their respective companies and are hereby acknowledged. All non-ELATION brands and product names are trademarks or registered trademarks of their respective companies.

ELATION PROFESSIONAL and all affiliated companies hereby disclaim any and all liabilities for property, equipment, building, and electrical damages, injuries to any persons, and direct or indirect economic loss associated with the use or reliance of any information contained within this document, and/or as a result of the improper, unsafe, insufficient, and negligent assembly, installation, rigging, and operation of this product.

Elation Professional USA | 6122 S. Eastern Ave. | Los Angeles, CA. 90040
 323-582-3322 | 323-832-9142 fax | www.elationlighting.com | info@elationlighting.com

Elation Professional B.V. | Junostraat 2 | 6468 EW Kerkrade, The Netherlands
 +31 45 546 85 66 | +31 45 546 85 96 fax | www.elationlighting.eu | info@elationlighting.eu

Elation Professional Mexico | AV Santa Ana 30 | Parque Industrial Lerma, Lerma, Mexico 52000
 +52 (728) 282-7070

DOCUMENT VERSION



Due to additional product features and/or enhancements, an updated version of this document may be available online. Please scan the QR Code with your mobile device or visit www.elationlighting.com for the latest revision/update of this manual before installation and/or programming.

Date	Document Version	Software Version ≥	DMX Channel Modes	Notes
06/12/19	1.0	1.4.1	37 / 61	Initial release.
10/09/19	1.1	N/C	NO CHANGE	Included RJ45 data cable note added.
08/14/20	1.2	N/C	NO CHANGE	Updated thermal
08/21/20	1.4	N/C	NO CHANGE	Updated framing index
10/02/20	1.6	N/C	NO CHANGE	Updated specs
01/27/21	1.8	1.4.4	NO CHANGE	Updated primary/secondary modes, Fixture Installation, DMX Channel Functions, Specifications
03/01/21	2.0	N/C	NO CHANGE	Added Transportation & Handling Precaution
05/21/21	2.2	N/C	NO CHANGE	Updated Maintenance.
07/14/21	2.4	N/C	NO CHANGE	Corrected DMX Traits.
01/11/22	2.6	N/C	NO CHANGE	ADDED FIL DIMENSIONS
04/20/22	2.8	N/C	NO CHANGE	Updated General Information, added RDM
08/16/22	3.0	1.8.0	NO CHANGE	Updated System Menu, DMX Traits, Torque Settings for Screws, Fixture Installation
10/12/22	3.1	N/C	NO CHANGE	Updated fan modes
11/07/22	3.2	1.8.1	NO CHANGE	Updated RDM, updated System Menu & DMX Traits
02/27/23	3.3	1.9.0	NO CHANGE	Added IP65 note, updated System Menu & DMX Traits
03/24/23	3.4	2.0.0	NO CHANGE	Updated System Menu & DMX Traits
06/20/24	3.5	N/C	NO CHANGE	Updated Fixture Installation, IP65 Rated

CONTENTS

General Information	4
Limited Warranty (USA Only)	5
IP65 Notice	6
Safety Guidelines	7
Fixture Transportation and Handling	9
Maintenance Guidelines	10
Fixture Overview	11
Colors, Gobos, Animation	12
Fan Modes and Low Noise Operation	13
Custom Gobos	14
Gobo Installation	15
Torque Settings for Screws	19
Fixture Installation	21
Sun Protection Mode Hibernation Mode	27
System Menu	28
E-FLY Wireless DMX Setup	36
Dimmer Curves	37
DMX Channel Functions and Values	38
Remote Device Management (RDM)	50
Error Codes	51
Specifications	52
Dimensional Drawings	53
Optional Accessories FCC Statement	56

GENERAL INFORMATION

INTRODUCTION

Please read and understand the instructions in this manual carefully and thoroughly before attempting to operate this device. These instructions contain important safety and use information. **This device is intended for use by professionally trained personnel only, and is not suitable for private use.**

IP65 RATED

An IP rated lighting fixture is one, which is commonly installed in outdoor environments and has been designed with an enclosure that effectively protects the ingress (entry) of external foreign objects such as dust and water. The **International Protection (IP)** rating system is commonly expressed as "**IP**" (Ingress Protection) followed by two numbers (i.e. IP65) where the numbers define the degree of protection. The first digit (Foreign Bodies Protection) indicates the extent of protection against particles entering the fixture and the second digit (Water Protection) indicates the extent of protection against water entering the fixture. An **IP65** rated lighting fixture is one, which has been designed and tested to protect against the ingress of dust (**6**) and low-pressure water jets from any direction (**5**).

NOTE: THIS FIXTURE IS INTENDED FOR TEMPORARY OUTDOOR USE ONLY!

UNPACKING

Every device has been thoroughly tested and has been shipped in perfect operating condition. Carefully check the shipping carton for damage that may have occurred during shipping. If the carton is damaged, carefully inspect the device for damage, and be sure all accessories necessary to install and operate the device have arrived intact. In the event damage has been found or parts are missing, please contact our customer support team for further instructions. Please do not return this device to your dealer without first contacting customer support. Please do not discard the shipping carton in the trash. Please recycle whenever possible.

BOX CONTENTS

Omega Brackets (x2)
IP65 Rated 5pin DMX Cable
IP65 Rated RJ45 Cable (Fixture to Fixture Interconnect Use Only!)
IP65 Power Cable

CUSTOMER SUPPORT

Contact **ELATION Service** for any product related service and support needs.
Also visit forums.elationlighting.com with questions, comments or suggestions.

ELATION SERVICE USA - Monday - Friday 8:00am to 4:30pm PST
323-582-3322 | Fax 323-832-9142 | support@elationlighting.com

ELATION SERVICE EUROPE - Monday - Friday 08:30 to 17:00 CET
+31 45 546 85 63 | Fax +31 45 546 85 96 | support@elationlighting.eu

REPLACEMENT PARTS please visit parts.elationlighting.com

LIMITED WARRANTY (USA ONLY)

- A. Elation Professional hereby warrants, to the original purchaser, Elation Professional products to be free of manufacturing defects in material and workmanship for a period of two years (730 days), and Elation Professional product rechargeable batteries to be free of manufacturing defects in material and workmanship for a period of six months (180 days), from the original date of purchase. This warranty excludes discharge lamps and all product accessories. This warranty shall be valid only if the product is purchased within the United States of America, including possessions and territories. It is the owner's responsibility to establish the date and place of purchase by acceptable evidence, at the time service is sought.
- B. For warranty service, send the product only to the Elation Professional factory. All shipping charges must be pre-paid. If the requested repairs or service (including parts replacement) are within the terms of this warranty, Elation Professional will pay return shipping charges only to a designated point within the United States. If any product is sent, it must be shipped in its original package and packaging material. No accessories should be shipped with the product. If any accessories are shipped with the product, Elation Professional shall have no liability what-so-ever for loss and/or or damage to any such accessories, nor for the safe return thereof.
- C. This warranty is void if the product serial number and/or labels are altered or removed; if the product is modified in any manner which Elation Professional concludes, after inspection, affects the reliability of the product; if the product has been repaired or serviced by anyone other than the Elation Professional factory unless prior written authorization was issued to purchaser by Elation Professional; if the product is damaged because not properly maintained as set forth in the product instructions, guidelines and/or user manual.
- D. This is not a service contract, and this warranty does not include any maintenance, cleaning or periodic check-up. During the periods as specified above, Elation Professional will replace defective parts at its expense, and will absorb all expenses for warranty service and repair labor by reason of defects in material or workmanship. The sole responsibility of Elation Professional under this warranty shall be limited to the repair of the product, or replacement thereof, including parts, at the sole discretion of Elation Professional. All products covered by this warranty were manufactured after January 1, 1990, and bare identifying marks to that effect.
- E. Elation Professional reserves the right to make changes in design and/or performance improvements upon its products without any obligation to include these changes in any products theretofore manufactured.
- F. No warranty, whether expressed or implied, is given or made with respect to any accessory supplied with the products described above. Except to the extent prohibited by applicable law, all implied warranties made by Elation Professional in connection with this product, including warranties of merchantability or fitness, are limited in duration to the warranty periods set forth above. And no warranties, whether expressed or implied, including warranties of merchantability or fitness, shall apply to this product after said periods have expired. The consumer's and/or dealer's sole remedy shall be such repair or replacement as is expressly provided above; and under no circumstances shall Elation Professional be liable for any loss and/or damage, direct and/or consequential, arising out of the use of, and/or the inability to use, this product.
- G. This warranty is the only written warranty applicable to Elation Professional products and supersedes all prior warranties and written descriptions of warranty terms and conditions heretofore published.

WARRANTY RETURNS

All returned service items whether under warranty or not, must be freight pre-paid and accompany a return authorization (R.A.) number. The R.A. number must be clearly written on the outside of the return package. A brief description of the problem as well as the R.A. number must also be written down on a piece of paper and included in the shipping container. If the unit is under warranty, you must provide a copy of your proof of purchase invoice. Items returned without a R.A. number clearly marked on the outside of the package will be refused and returned at customer's expense. You may obtain a R.A. number by contacting customer support.

IP65 RATED

The International Protection (IP) rating system is commonly expressed as “IP” (Ingress Protection) followed by two numbers (i.e. IP65), where the numbers define the degree of protection. The first digit (Foreign Bodies Protection) indicates the extent of protection against particles entering the fixture, and the second digit (Water Protection) indicates the extent of protection against water entering the fixture. An IP65 rated lighting fixture is designed and tested to protect against the ingress of dust (6), and low-pressure water jets from any direction (5).

NOTE: THIS FIXTURE IS INTENDED FOR TEMPORARY OUTDOOR USE ONLY!

Maritime/Coastal Environment Installations: A coastal environment is seaside adjacent, and caustic to electronics through exposure to atomized salt-water and humidity, whereas maritime is anywhere within 5-miles of a coastal environment.



NOT suitable for maritime/coastal environment installations. Installing this fixture in a maritime/coastal environment may cause corrosion and/or excessive wear to the interior and/or exterior components of the fixture. Damages and/or performance issues resulting from installation in a maritime/coastal environment will void the manufactures warranty, and will NOT be subject to any warranty claims and/or repairs.

Maritime installations require additional preparation, and additional service intervals may be needed given the maritime use. In general, IP ratings presuppose freshwater conditions VS maritime conditions, which are typically more “caustic” to IP fixtures (both internally and externally). A duty-cycle may also be needed when units are not in use. During times of high humidity and colder temperatures, condensation may occur internally so the fixture may require a duty-cycle to bring it up to running temperature, allowing any accumulation of moisture to be expelled via the vent valve. Recommendations can change based on installation environmental circumstances. A waterproof dome or similar device is recommended for use in permanent outdoor installations. When using a dome, refer to manufacturer recommendations for duty-cycle.

NOTE: NOT ALL FEATURES LISTED ARE AVAILABLE ON ALL FIXTURES; THE FOLLOWING INSTRUCTIONS MAY NOT APPLY. CONTACT SUPPORT FOR ADDITIONAL DETAILS.

Exterior Maintenance: Inspect the exterior every 30-days. The unit must be powered off/disconnected. Inspect optics to determine if the lens is obstructed, then clean optics and chassis accordingly. Based on initial finding, schedule maintenance accordingly, keeping in mind that exterior maintenance will be required. Even if the luminaires are NOT in use, maintenance will still be needed given its location (exterior use). The use of a durable type of wax on the chassis is recommended since it will help prevent contaminant build up. Inspect both power and data lines for any signs of contaminants or corrosion. Periodically reapplying di-electric grease, especially in coastal environments. If any signs of corrosion/contaminants are present, clean thoroughly, and/or replace connectors, then reapply di-electric grease. Typically, this should be done annually, or any time an opportunity presents itself. As a preventive measure, annual replacement of both vent valves is recommended. The vent valve membrane can become contaminated and/or clogged causing improper venting of humidity within the luminaire. Inspect all mounting hardware as a precaution.

Interior Maintenance: Inspect the interior every 30-days. The unit must be powered off/disconnected.

Inspect zoom/focus mechanism, clean optics, lubricate linear bearings (Krytox oil) as needed, inspect belts for wear

Inspect all rotating effect wheels, manually rotate them, note any resistance

Inspect all remaining rotating belts for any wear

Inspect all fans, clean as needed, check rotation, check connections

Inspect CMY module, manually move flags and check for signs of resistance, and if needed, clean guide rods first, then reapply a thin layer of grease (moly lube)

Clean interior with low-volume compressed air, then clean optics prior to reassembly of head covers

Although the base has limited moving parts, the pan belt should also be inspected for wear. Remember to always perform an IP test anytime a cover is removed.

There is no specific time frame regarding the routine replacement of parts such as belts/stepper motors, PCBs, or LEDs. These items should only be replaced on an as needed bases, except for cooling fans, which should be replaced once the luminaries reach 10,000-hours. This is a prophylactic measure intended to keep the unit running as cool as possible, insuring proper function of all internal components. A complete service breakdown is available, please contact service@elationlighting.com for any needed parts or manuals.

SAFETY GUIDELINES

This fixture is a sophisticated piece of electronic equipment. To guarantee a smooth operation, it is important to follow all instructions and guidelines in this manual. Elation Professional is not responsible for injury and/or damages resulting from the misuse of this fixture due to the disregard of the information printed in this manual. Only qualified and/or certified personnel should perform installation of this fixture and only the original rigging parts (omega brackets) included with this fixture should be used for installation. Any modifications to the fixture and/or the included mounting hardware will void the original manufactures warranty and increase the risk of damage and/or personal injury.



PROTECTION CLASS 1 - FIXTURE MUST BE PROPERLY GROUNDED

**THERE ARE NO USER SERVICEABLE PARTS INSIDE THIS UNIT.
DO NOT ATTEMPT ANY REPAIRS YOURSELF; DOING SO WILL VOID YOUR
MANUFACTURES WARRANTY. DAMAGES RESULTING FROM MODIFICATIONS
TO THIS FIXTURE AND/OR THE DISREGARD OF SAFETY INSTRUCTIONS AND
GUIDELINES IN THIS MANUAL VOID THE MANUFACTURES WARRANTY AND
ARE NOT SUBJECT TO ANY WARRANTY CLAIMS AND/OR REPAIRS.**



**DO NOT PLUG FIXTURE INTO A DIMMER PACK!
NEVER OPEN THIS FIXTURE WHILE IN USE!
UNPLUG POWER BEFORE SERVICING FIXTURE!
NEVER TOUCH FIXTURE DURING OPERATION, AS IT MAY BE HOT!
KEEP FLAMMABLE MATERIALS AWAY FROM FIXTURE!**



**NEVER LOOK DIRECTLY INTO THE LIGHT SOURCE!
RETINA INJURY RISK - MAY INDUCE BLINDNESS!
SENSITIVE PERSONS MAY SUFFER AN EPILEPTIC SHOCK!**



**ENSURE ALL CONNECTIONS AND END CAPS ARE PROPERLY SEALED WITH A
DIELECTRIC GREASE (AVAILABLE AT MOST ELECTRICAL SUPPLIERS) TO
PREVENT WATER CORROSION AND/OR ELECTRICAL SHORT CIRCUIT.**



**MINIMUM DISTANCE TO OBJECTS/SURFACES
MUST BE 10 FEET (3 METERS)
MAXIMUM TEMP OF EXTERNAL SURFACE 212° F (100°C)
MINIMUM DISTANCE OF INFLAMMABLE MATERIALS
FROM THE SURFACE 1.6 FEET (0.5 METER)**

SAFETY GUIDELINES

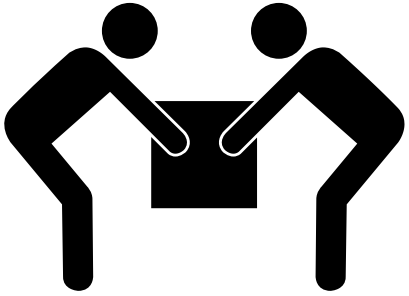
 <p>117 lbs. (53kg)</p>	<p>WARNING</p> <p>TWO PERSON LIFT REQUIRED</p>
--	--

CAUTION

HIGH INTENSITY ULTRAVIOLET LIGHT



AVOID DIRECT EYE & SKIN EXPOSURE.
WEAR PROPER EYE & SKIN PROTECTION.
SEE MANUAL FOR SAFETY INSTRUCTIONS.

RISK GROUP 3 - RISK OF EXPOSURE TO ULTRAVIOLET UV RADIATION! FIXTURE EMITS HIGH INTENSITY WAVELENGTH OF ULTRAVIOLET UV LIGHT FROM THE UV COLOR FILTER. WEAR PROPER EYE AND SKIN PROTECTION. AVOID PROLONGED PERIODS OF EXPOSURE TO UV COLOR FILTER. AVOID WEARING WHITE COLOR CLOTHING AND/OR USING UV PAINTS ON SKIN. AVOID DIRECT EYE AND/OR SKIN EXPOSURE AT DISTANCES LESS THAN 11 feet (3.3m). DO NOT OPERATE FIXTURE WITH DAMAGED/MISSING EXTERNAL COVERS. DO NOT LOOK DIRECTLY INTO THE UV LIGHT AND/OR VIEW UV LIGHT DIRECTLY

WITH OPTICAL INSTRUMENTS THAT MAY CONCENTRATE THE LIGHT/RADIATION OUTPUT. INDIVIDUALS SUFFERING FROM A RANGE OF EYE CONDITIONS, SUNLIGHT EXPOSURE DISORDERS, OR INDIVIDUALS USING PHOTOSENSITIVE MEDICATION, MAY RECEIVE DISCOMFORT IF EXPOSED TO THE ULTRAVIOLET UV LIGHT EMITTED FROM THE UV LED.

DO NOT TOUCH the fixture housing during operation. Turn OFF the power and allow approximately 15 minutes for the fixture to cool down before serving.

DO NOT shake fixture, avoid brute force when installing and/or operating fixture.

DO NOT operate fixture if the power cord is frayed, crimped, damaged and/or if any of the power cord connectors are damaged and do not insert into the fixture securely with ease. **NEVER** force a power cord connector into the fixture. If the power cord or any of its connectors are damaged, replace it immediately with a new one of similar power rating.

DO NOT block any air ventilation slots.

All fan and air inlets must remain clean and never blocked.

Allow approx. 6" (15cm) between fixture and other devices or a wall for proper cooling.

Always disconnect fixture from main power source before performing any type of service and/or cleaning procedure. Only handle the power cord by the plug end, never pull out the plug by tugging the wire portion of the cord.

During the initial operation of this fixture, a light smoke or smell may emit from the interior of the fixture. This is a normal process and is caused by excess paint in the interior of the casing burning off from the heat associated with the lamp and will decrease gradually over time.

Consistent operational breaks will ensure fixture will function properly for many years.

ONLY use the original packaging and materials to transport the fixture in for service.

FIXTURE TRANSPORT AND HANDLING

POTENTIAL INTERNAL DAMAGE FROM 'TIPPING' FIXTURE DURING TRANSPORT AND HANDLING

Note that not all features listed are available on all fixtures; the following instructions may not apply.

Depending on the model, large format fixtures may contain delicate optics and glass filters. While this product was carefully designed to be roadworthy, it must be handled carefully during transportation. If the fixture contains color flags, before transport, ensure that color flags inside the unit are placed in an OPEN position.

For superior impact protection, some fixtures are shipped in a custom fitted high-density Foam Inlay (FIL). This FIL must be used inside the road-cases for transportation.

DO NOT TIP THE CASE OVER, AND AVOID ALL SHOCKS AND ROUGH HANDLING, ESPECIALLY "TIPPING", THE PRACTICE OF TIPPING THE FIXTURE-CASE OVER TO ITS SIDE AND ONTO A HARD SURFACE. THE CASE MUST RIDE ON ITS WHEELS SO THAT THE FIXTURE-HEAD REMAINS HORIZONTAL DURING TRANSPORTATION.

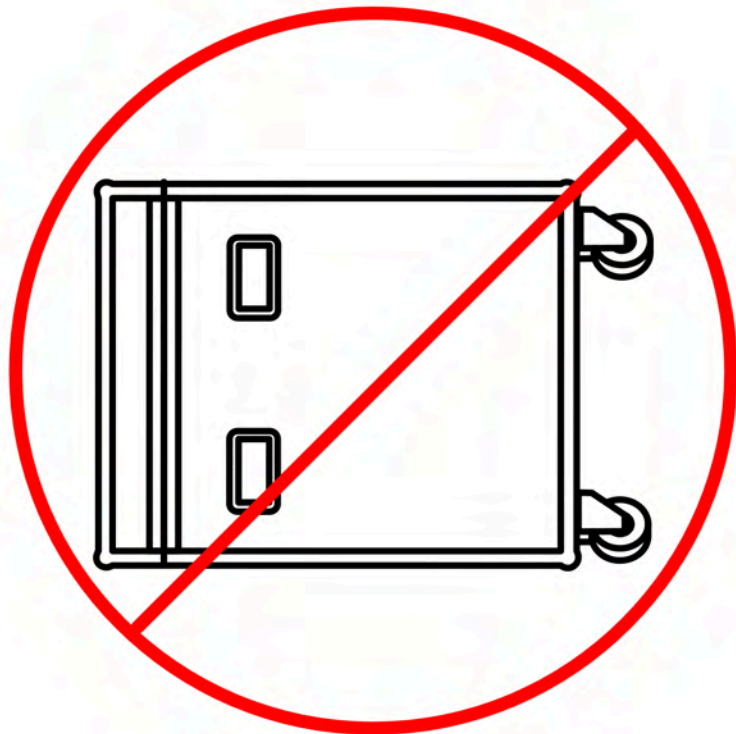
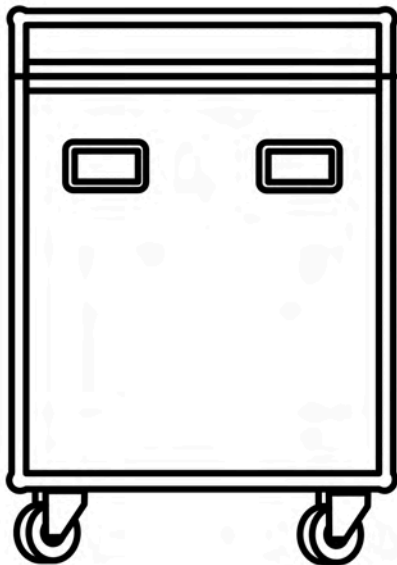

MAINTENANCE GUIDELINES



DISCONNECT POWER BEFORE PERFORMING ANY MAINTENANCE!

CLEANING

Frequent cleaning is recommended to insure proper function, optimized light output, and an extended life. The frequency of cleaning depends on the environment in which the fixture operates: damp, smoky or particularly dirty environments can cause greater accumulation of dirt on the fixture's optics. Clean the external lens surface at least every 20 days with a soft cloth to avoid dirt/debris accumulation.

NEVER use alcohol, solvents, or ammonia-based cleaners.

MAINTENANCE

Regular inspections are recommended to insure proper function and extended life.

There are no user serviceable parts inside this fixture, please refer all other service issues to an authorized Elation service technician. Should you need any spare parts, please order genuine parts from your local Elation dealer.

Please refer to the following points during routine inspections:

- A detailed electric check by an approved electrical engineer every three months, to make sure the circuit contacts are in good condition and prevent overheating.
- Be sure all screws and fasteners are securely always tightened. Loose screws may fall out during normal operation resulting in damage or injury as larger parts could fall.
- Check for any deformations on the housing, color lenses, rigging hardware and rigging points (ceiling, suspension, trussing). Deformations in the housing could allow for dust to enter the fixture. Damaged rigging points or unsecured rigging could cause the fixture to fall and seriously injure a person(s).
- Electric power supply cables must not show any damage, material fatigue or sediments. **NEVER** remove the ground prong from the power cable.

FIXTURE DISASSEMBLY

The following points should be observed after performing any maintenance procedure that requires disassembly of the unit:

- After the unit has been reassembled, open the valve, and allow the light to run for approximately 2 hours to dry out any moisture that has been trapped inside the fixture. The process should continue until indicated humidity drops below 15% for the head and 30% for the base.
- Once this has been achieved, the light can be switched off, but the unit should remain connected to power so that the cooling fan can cool down the unit. Please note that allowing cool down time should **ALWAYS** be done after lamp operation.
- Some units may require partial disassembly to gain access to the valve. Please contact Elation service for information regarding the location and access procedure for the valve on your specific unit model.

FIXTURE OVERVIEW

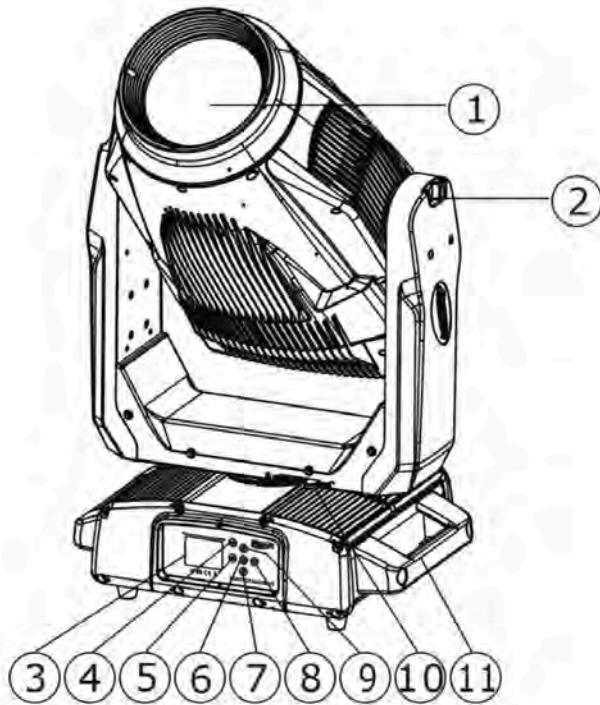

1. Lens
2. Tilt Lock
3. System Menu LCD Display
4. MODE/ESC Button
5. LEFT Button
6. ENTER Button
7. DOWN Button
8. RIGHT Button
9. UP Button
10. Pan Lock
11. Carrying Handle(s)
12. Fuse
13. Power Input
14. RJ45 Input
15. Valve
16. RJ45 Output
17. 5pin DMX Input
18. 5pin DMX Output

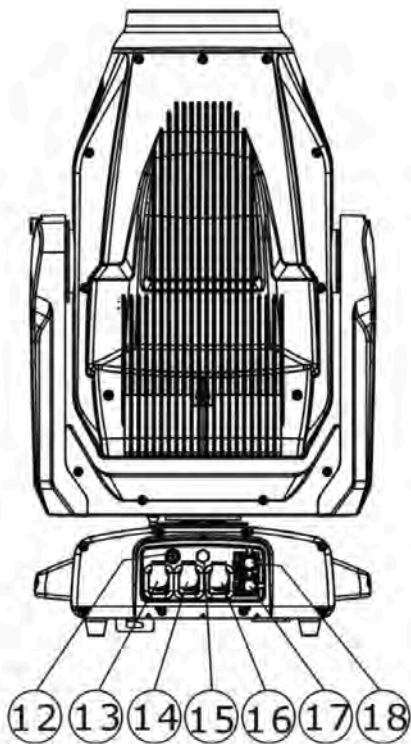

COLORS, GOBOS, ANIMATION

COLOR FLAGS

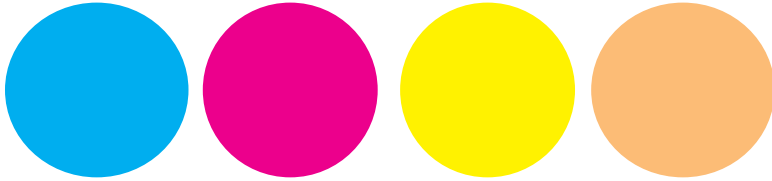

CYAN MAGENTA YELLOW C.T.O.

COLOR WHEEL

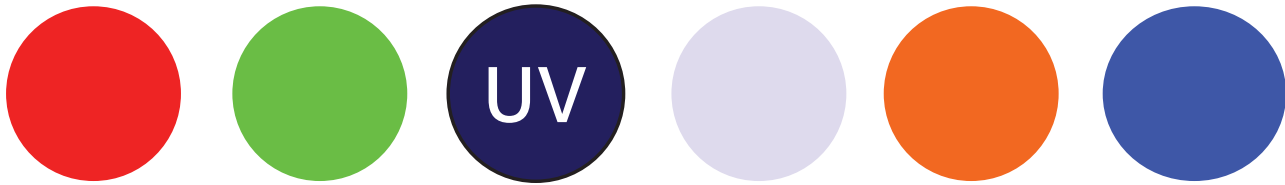

RED GREEN U V HIGH CRI ORANGE BLUE

INTERCHANGEABLE-ROTATING GLASS GOBO WHEEL 1



INTERCHANGEABLE-STATIC GLASS GOBO WHEEL 2



ANIMATION WHEEL

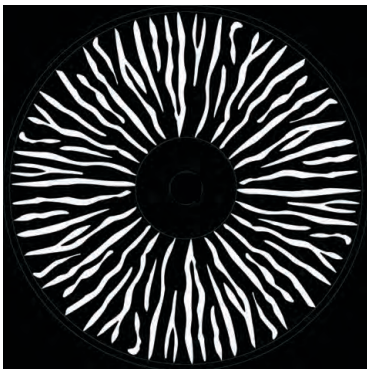

FAN MODES and LOW NOISE OPERATION

The Proteus Maximus is a high-performance fixture suited for multiple applications. For noise critical environments such as Theater, Opera or Orchestra Halls, it offers various fan operation modes which remove any distraction for the audience and performers. Fan Modes can be changed remotely via the DMX control channel, allowing the fixture to offer high output or whisper silent operation at a moment's notice. All Fan Modes smoothly transition over a brief time, preventing unwanted attraction to the fixture.

Mode	dbA at 1m LED off	dbA at 1m Dimmer 100%
Fan Control - Auto (Default)	39	47
Fan Control - High	40	55
Low Noise – Silent	31	31

Auto (Default) –Fans only run at the speeds needed to keep the LED engine within a safe temperature range and ensures optimal performance of the fixture. If possible, they will turn-off, for example, when the fixture is dimmed to a low intensity. Fans sense the ambient and fixture temperature, and will always try to keep noise levels to a minimum. The fixture output will only reduce when the LED engine cannot be cooled down to its safe operating range due to high ambient temperature.

NOTE: Recommended for daily operation.

High – Fan speeds are increased throughout for the most efficient cooling of the fixture. This mode will increase wear on the fans and should only be utilized in exceptional circumstances. Fans will always run, even if the fixture is dimmed down. Fixture output is kept at 100% unless the LED engine temperature reaches an unsafe temperature at which point the fixture will reduce power carefully to ensure continued safe operation. This mode is only required in very high ambient temperatures when automatic fan speed adjustments are not desired.

Silent

Fan speeds are reduced throughout the fixture for a lower noise profile. The fixture output is also reduced to approximately 80%. This mode should be sufficient for most uses where lower noise is required.

CUSTOM GOBOS

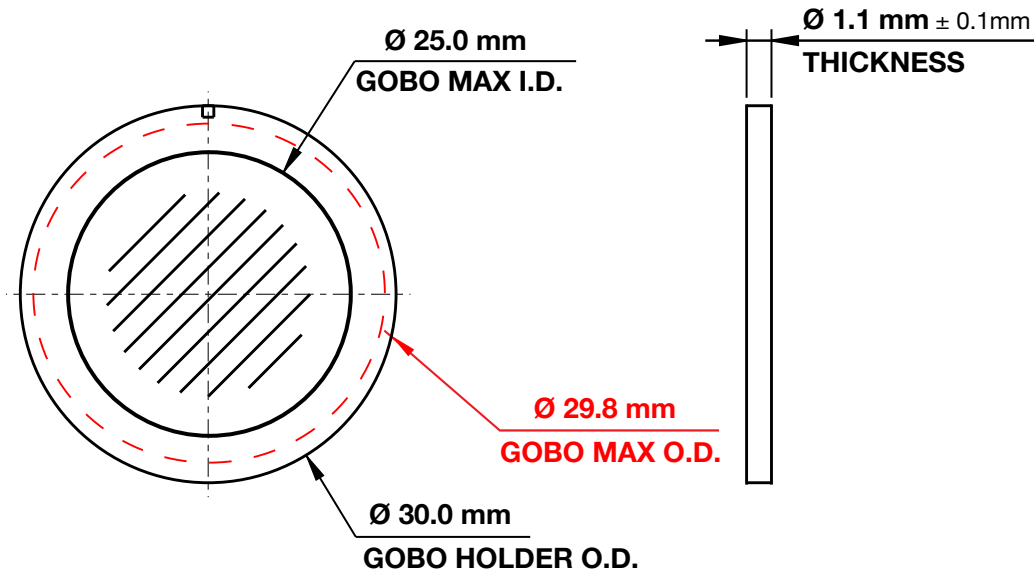

ROTATING & STATIC GLASS GOBOS - WHEEL 1 + 2	
Gobo O.D. (Max. Outer Diameter)	$\text{Ø}29.8\text{mm}$
Gobo I.D. (Max. Image Diameter)	$\text{Ø}25.0\text{mm}$
Gobo Holder Diameter	$\text{Ø}30.0\text{mm}$
Gobo Thickness	$1.1\text{mm}\pm 0.1\text{mm}$
Gobo Material	High Temp Glass (Minimum 600C°)

* * * IMPORTANT NOTICE REGARDING CUSTOM GOBOS * * *

Due to the high temperature optical system, special material as listed above is required for custom gobos. Due to varying manufacturing processes and tolerances, it is highly recommended to provide a gobo sample and holder from the fixture to the custom gobo vendor for accurate sizing. Extended testing of custom gobo designs is highly recommended prior to use. Contact ELATION SERVICE for further information.

ELATION SERVICE USA - Monday - Friday 8:00am to 4:30pm PST

323-582-3322 | Fax 323-832-9142 | support@elationlighting.com

ELATION SERVICE EUROPE - Monday - Friday 08:30 to 17:00 CET

+31 45 546 85 63 | Fax +31 45 546 85 96 | support@elationlighting.eu

GOBO INSTALLATION



1. Before removing covers, place fixture on a stable flat surface in an **INDOOR DUST FREE** location. Ensure moving head is locked into a neutral upright position with both PAN and TILT locks engaged.



2. Remove (2x) Phillips-head screws on the bottom cover to expose the safety cables for the front and back covers. With bottom cover removed, remove the (10x per cover) Phillips-head screws on the front and back covers. One at a time, gently lift the covers and unclip the safety cables to remove them completely from the fixture.

GOBO INSTALLATION

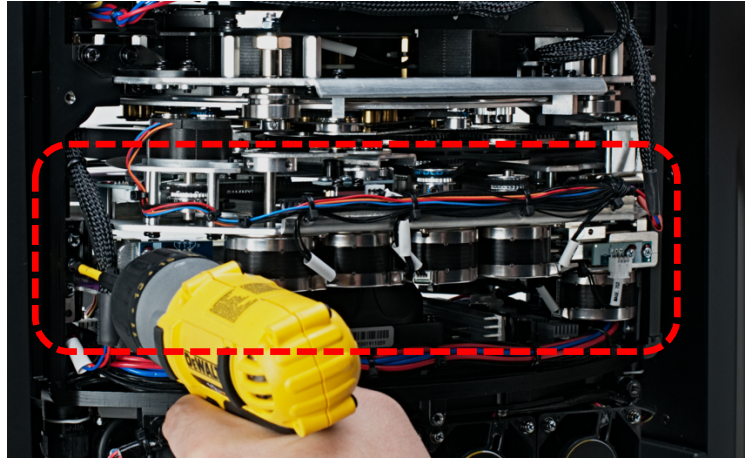
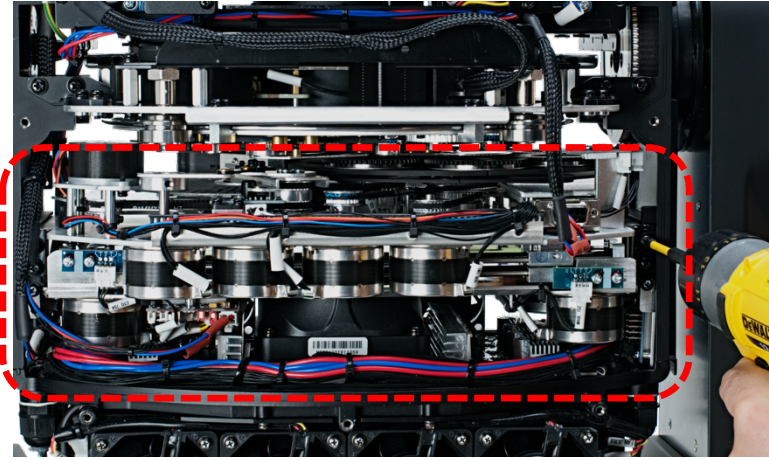

3. The GOBO Wheel module is secured to the fixture frame rail with (2x) sliding slotted brackets. To remove the module, loosen the (4x) Philips-head screws holding the brackets just enough (do not remove them) to allow the slotted brackets to slide down.

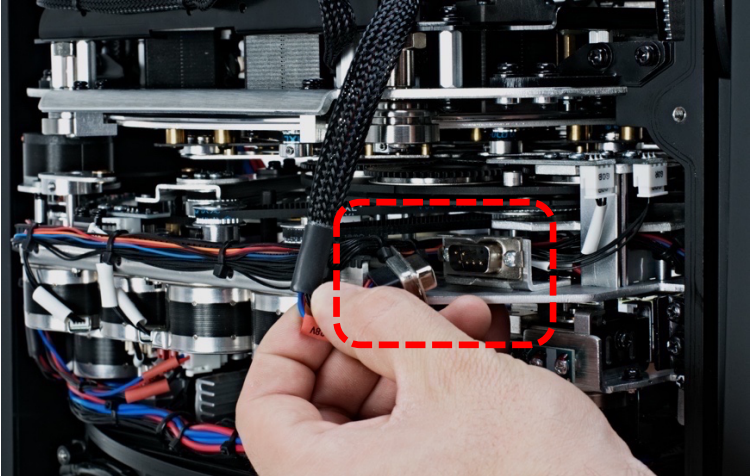
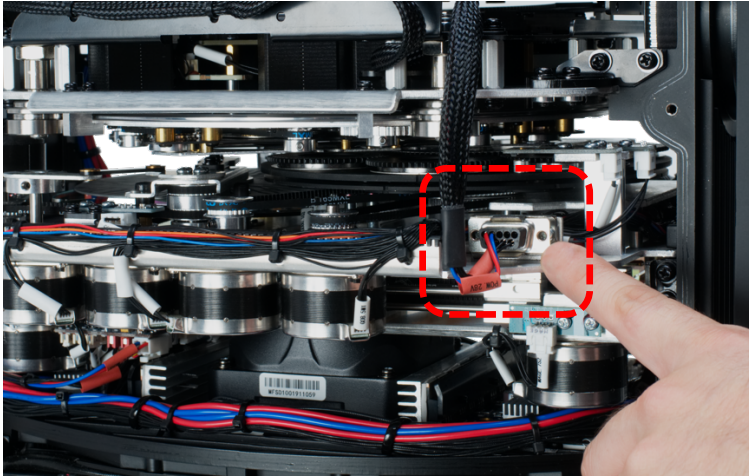

4. Locate the 9-pin connector and carefully unplug it from its socket. **DO NOT USE FORCE TO REMOVE!**

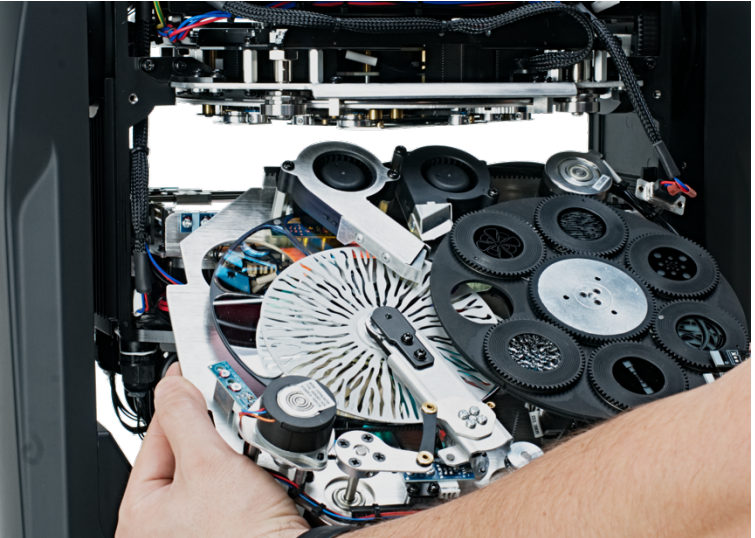
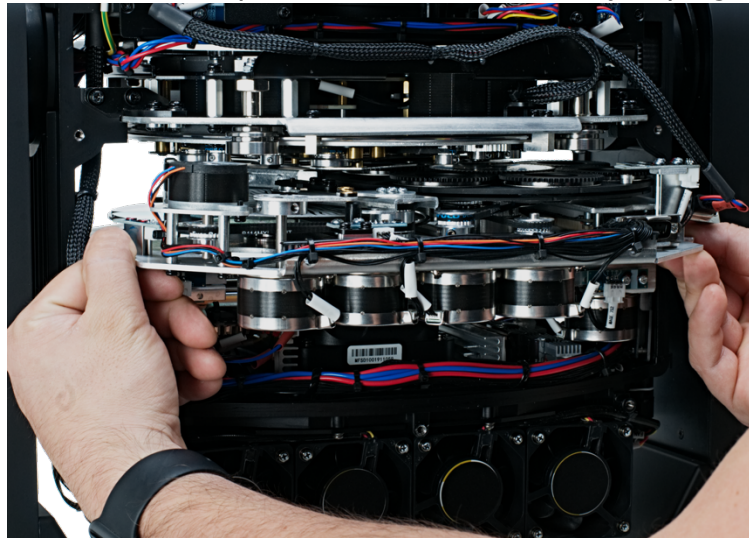

5. Carefully grip the GOBO Wheel module and slid it out and away to clear the mounting rails.

GOBO INSTALLATION

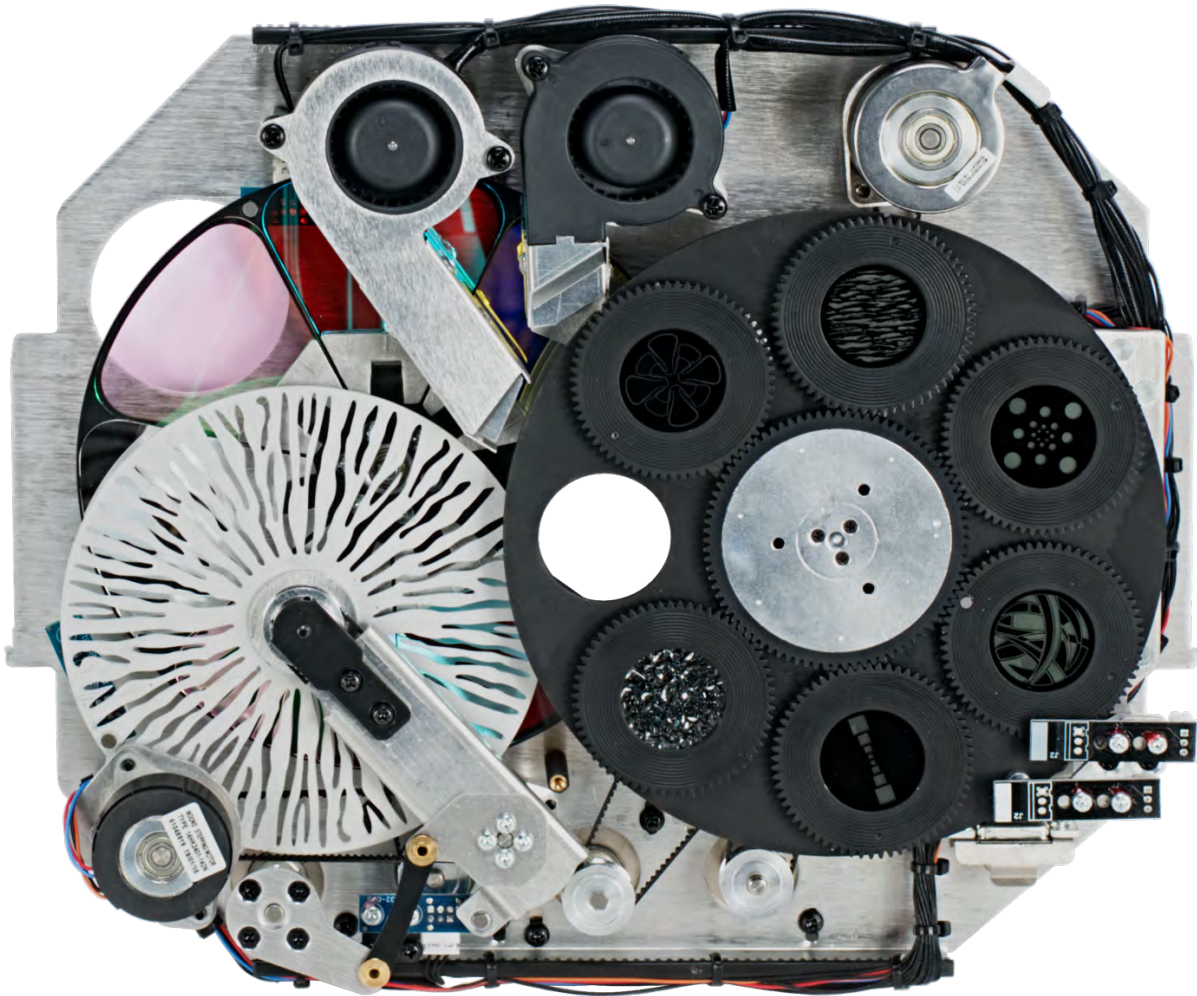

6. Carefully place the module on a stable flat surface in an **INDOOR DUST FREE** location.



7. REPLACING A ROTATING GOBO

Locate the specific Rotating GOBO to replace. Carefully grip the GOBO using your thumb and index finger, gently lifting it slightly and then pulling it out and away until it fully clears the GOBO Wheel.

GOBO INSTALLATION



8. Locate the tab of the spring, and with a precision pick (or similar tool), carefully press the retaining spring inward to relieve the tension. Remove the retaining spring and carefully separate the GOBO from the GOBO Holder. Lastly, remove the flat washer attached to the removed GOBO and attach it to the desired replacement GOBO. Install the replacement Rotating GOBO following the steps above in reverse order.



CAUTION: TAKE CARE NOT TO SCRATCH GOBO OR GOBO HOLDER



9. REPLACING A STATIC GOBO

Rotate the Static GOBO Wheel until the desired GOBO is visible through the OPEN slot in the Rotating GOBO Wheel. Using a precision pick (or similar tool), carefully press the Static GOBO Holder down slightly then using your thumb and index finger, gently pull it out and away until it fully clears the GOBO Wheel.

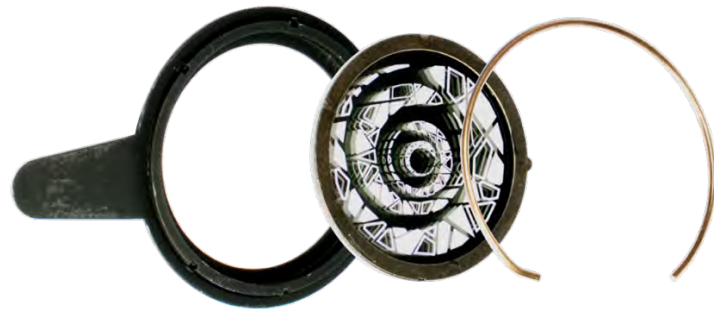

10. Locate the tab of the retaining spring. Using a precision pick (or similar tool), carefully press the retaining spring inward to relieve the tension. Remove the retaining spring and carefully separate the GOBO from the GOBO Holder. Lastly, remove the flat washer attached to the removed GOBO and attach it to the desired replacement GOBO. Install the replacement Static GOBO following the steps above in reverse order.



CAUTION: TAKE CARE NOT TO SCRATCH GOBO OR GOBO HOLDER

TORQUE SETTINGS FOR SCREWS



The hex-head screws holding either the panels or the base **MUST** be tightened with a torque wrench (not included).

TORQUE SETTING = 11 lbf-in. (12.7kgf-cm)*

* lbf-in = Pound Force Inches | kgf-cm = Kilogram Force Centimeters

TORQUE SETTINGS FOR SCREWS



CAUTION! DO NOT OVER TORQUE SCREWS AS THIS CAN CAUSE LEAKAGE ISSUES! TO CONFIRM THE IP65 INTEGRITY AFTER MAINTENANCE AND REASSEMBLY, TEST FIXTURE USING THE ELATION IP TESTER. CONTACT ELATION SERVICE FOR MORE DETAILS.



CAUTION! THE USER OF PROTECTIVE GLOVES AND SAFETY GOGGLES IS STRONGLY RECOMMENDED WHILE PERFORMING THE IP PRESSURE TEST! AVOID PLACING YOUR FACE, EYES, HANDS, ETC IN CLOSE PROXIMITY TO THE FIXTURE'S LENS WHILE PERFORMING THE TEST!

IP PRESSURE TESTING PARAMETERS			
Test Type	Low Pressure Limit	High Pressure Limit	Hold Time
Vacuum Test	-4.35 psi (-30.00 KPa)	-5.08 psi (-35.00 KPa)	10 s
Pressure Test	3.62 psi (25.00 KPa)	4.35 psi (30.00 KPa)	10 s

FIXTURE INSTALLATION

It is important to follow proper storage procedures to ensure the longevity and functionality of IP rated fixtures, especially those with an IP6X rating or higher. The following are guidelines for the proper storage of such fixtures in road cases:

- **Ensure Dryness:** Dry the unit completely before placing in a road case, as moisture on the fixture in an enclosed space can result in moisture intrusion and damage, even for fixtures that are designed to be moisture resistant. Check road cases and foam inlays (FILs) periodically for dampness or moisture, and take all possible measures to keep them dry at all times.
- **Preventative Measures:** Consider using moisture-absorbing materials like silica gel packs inside the road case to help mitigate any humidity that may build up over time. When considering a case design, it is advisable to incorporate a small vent to prevent moisture buildup inside the case.
- **Documentation:** Carefully document storage conditions as well as any preventive measures taken. This can be useful for reference during regular inspections and can help with troubleshooting any issues that may arise.
- **Climate Considerations:** Be mindful of the climate and environmental conditions in locations where the road cases are stored. The case may not be fully effective at protecting the fixture from extreme temperatures or high humidity.
- **Repairing Damage:** Scratches or other damage to the exterior of the fixture should be touched up, filled in, or otherwise repaired, as such damage can provide a pathway for moisture intrusion and/or corrosion.

By adhering to these guidelines, you can help safeguard your IP fixtures and extend their lifespan by preventing moisture-related issues that could lead to corrosion or other damage. Regular maintenance and checks are crucial to ensuring that the fixtures are stored in optimal conditions.

FIXTURE INSTALLATION



FLAMMABLE MATERIAL WARNING

Keep fixture minimum 5.0 feet (1.5m) away from flammable materials and/or pyrotechnics.



ELECTRICAL CONNECTIONS

A qualified electrician should be used for all electrical connections and/or installations.



USE CAUTION WHEN POWER LINKING OTHER MODEL FIXTURES AS THE POWER CONSUMPTION OF OTHER MODEL FIXTURES MAY EXCEED THE MAX POWER OUTPUT ON THIS FIXTURE. CHECK SILK SCREEN FOR AMX AMPS.



**MINIMUM DISTANCE TO OBJECTS/SURFACES
MUST BE 10 FEET (3 METERS)**



**MINIMUM DISTANCE OF INFLAMMABLE MATERIALS
FROM THE SURFACE 1.6 FEET (0.5 METER)**



MAXIMUM TEMPERATURE OF EXTERNAL SURFACE 212° F (100°C)



DO NOT INSTALL THE FIXTURE IF YOU ARE NOT QUALIFIED TO DO SO!

Fixture **MUST** be installed following all local, national, and country commercial electrical and construction codes and regulations.

Before rigging/mounting a single fixture or multiple fixtures to any metal truss/structure or placing the fixture(s) on any surface, a professional equipment installer **MUST** be consulted to determine if the metal truss/structure or surface is properly certified to safely hold the combined weight of the fixture(s), clamps, cables, and accessories.

Overhead rigging requires extensive experience, including amongst others calculating working load limits, installation material being used, and periodic safety inspection of all installation material and the fixture. If you lack these qualifications, do not attempt the installation yourself. Improper installation can result in bodily injury.

Fixture ambient operating temperature range is **-4° to 113°F. (-20° to 45°C)**

Do not use the fixture under or above this temperature.

Fixture(s) should be installed in areas outside walking paths, seating areas, or away from areas where unauthorized personnel might reach the fixture by hand.

NEVER stand directly below the fixture(s) when rigging, removing or servicing.

Overhead fixture installation must always be secured with a secondary safety attachment, such as an appropriately rated safety cable.

Allow approximately 15 minutes for the fixture to cool down before serving.

FIXTURE INSTALLATION

OMEGA BRACKETS INSTALLATION

Insert the Omega Brackets into the matching holes on the bottom of the fixture. Secure the Omega Brackets to the fixture by turning each quick-lock fastener ¼ turn clockwise; making sure the fastener is completely locked. Omega Brackets can be installed into the fixture base as illustrated below.



CLAMP INSTALLATION

When mounting fixture to truss, be sure to secure an appropriately rated professional grade rigging clamp to the included **Omega Brackets** using an M10 screw fitted through the center hole of the **Omega Brackets**. The fixture provides a built-in rigging point for a **SAFETY CABLE**. Be sure to only use one of the designated rigging points for the safety cable and never secure a safety cable to a carrying handle.

RIGGING

Overhead rigging requires extensive experience, including amongst others calculating working load limits, installation material being used, and periodic safety inspection of all installation material and the fixture. If you lack these qualifications, do not attempt the installation yourself. Improper installation can result in bodily injury.



ALWAYS ATTACH AN APPROPRIATELY RATED SAFETY CABLE (NOT INCLUDED) THAT MEETS ALL LOCAL, NATIONAL, AND COUNTRY CODES AND REGULATIONS WHENEVER INSTALLING FIXTURE IN A SUSPENDED ENVIRONMENT!

ART-NET | sACN CONNECTION

When connecting fixture to a network switch to control multiple devices, a **Gigabit Ethernet Switch** that supports **IGMP (Internet Group Management Protocol)** is required. Using a **Gigabit Ethernet Switch** that does not support **IGMP** can cause erratic behavior of all connected devices to the switch. Click link below for more information about IGMP.

https://en.wikipedia.org/wiki/Internet_Group_Management_Protocol

FIXTURE INSTALLATION

POWER AND DATA CABLES



TO MAINTAIN THE IP65 RATING INTEGRITY OF THE FIXTURE, ALL CABLES MUST BE RUN TOWARDS THE GROUND TO PREVENT WATER ACCUMULATION AROUND THE CONNECTIONS. (see illustration below)

SYSTEM MENU LCD DISPLAY

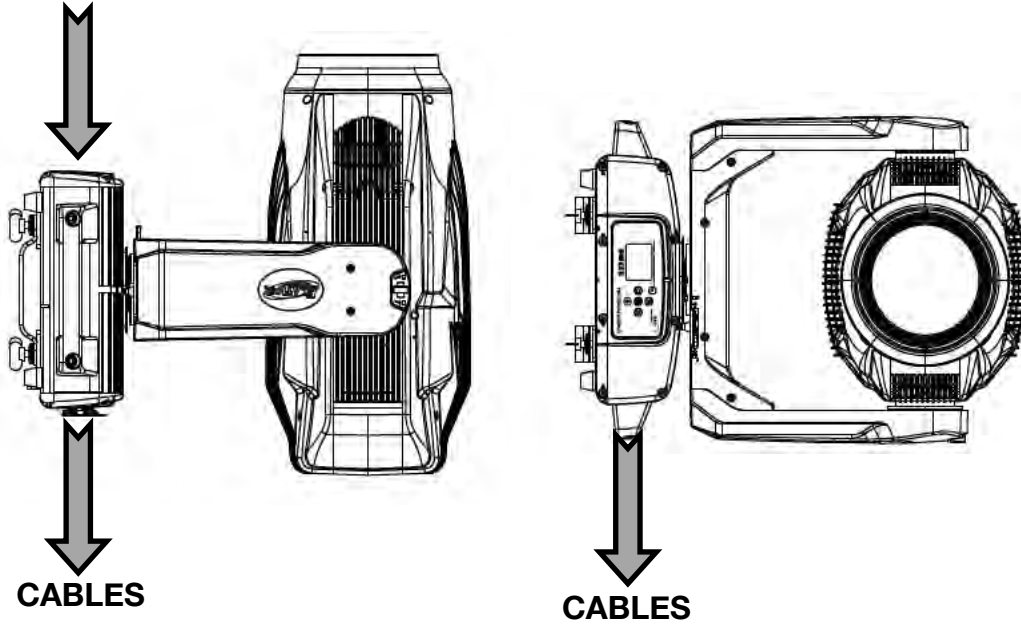

INCLUDED RJ45 DATA CABLE



THE INCLUDED RJ45 DATA CABLE IS FOR FIXTURE-TO-FIXTURE INTERCONNECT ONLY! THE RJ45 CABLE CONNECTORS MAY NOT BE COMPATIBLE WITH OTHER RJ45/ETHERNET TYPE CONNECTORS.

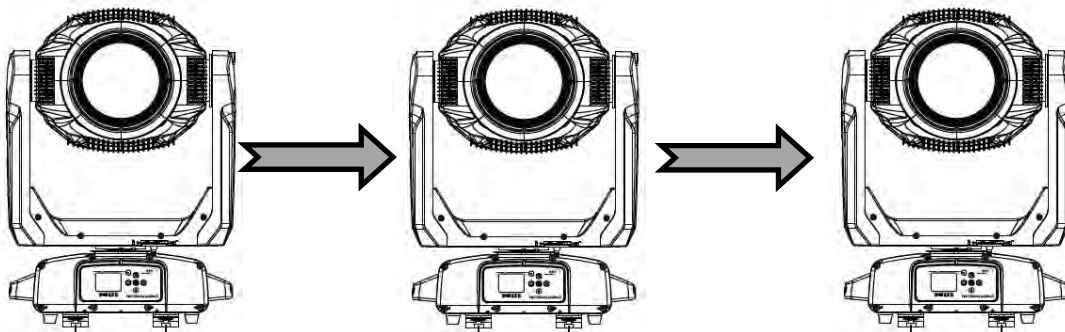

FIXTURE INSTALLATION

POWER AND DATA CONNECTIONS



ENSURE ALL CONNECTIONS AND END CAPS ARE PROPERLY SEALED WITH A DIELECTRIC GREASE (AVAILABLE AT MOST ELECTRICAL SUPPLIERS) TO PREVENT WATER CORROSION AND/OR ELECTRICAL SHORT CIRCUIT.



TO MAINTAIN IP65 RATING INTEGRITY AND PREVENT WATER FROM ENTERING THE FIXTURE, SEAL ALL UNUSED CONNECTION RUBBER CAPS.



SAFETY CABLE RIGGING POINT

ALWAYS ATTACH A SAFETY CABLE WHENEVER INSTALLING THIS DEVICE IN A SUSPENDED ENVIRONMENT TO ENSURE THE FIXTURE WILL NOT DROP IF THE CLAMP FAILS.

FIXTURE INSTALLATION

POTENTIAL INTERNAL FIXTURE DAMAGE FROM EXTERNAL SOURCES OF LIGHT BEAMS

External sources of light beams from direct sunlight, lighting moving head fixtures, and lasers, which are focused directly on the exterior housing and/or penetrate the front lens opening of ELATION lighting fixtures, can cause severe internal damage including burning to optics, dichroic color filters, glass and metal gobos, prisms, animation wheels, frost filters, iris, shutters, motors, belts, wiring, discharge lamps, and LEDs.

This issue is not specific only to ELATION lighting fixtures, it is a common issue with lighting fixtures from all manufacturers. Although there is no true way to fully prevent this issue from happening, the guidelines below can prevent any potential damage from occurring if followed. Contact ELATION Service for more details.

DO NOT EXPOSE THE FIXTURE AND/OR FRONT LENS OPENING TO LIGHT BEAMS FROM DIRECT SUNLIGHT, OTHER LIGHTING MOVING HEAD FIXTURES, AND LASERS WHILE UNPACKING, INSTALLATION, USE, AND EXTENDED IDLE TIMES OUTDOORS. DO NOT FOCUS A LIGHT BEAM FROM ONE LIGHTING FIXTURE DIRECTLY TOWARDS ANOTHER.

Note: See 'DMX Traits: Fixture' table on page 48 under 'Control' for channel values to engage or disengage these functions.

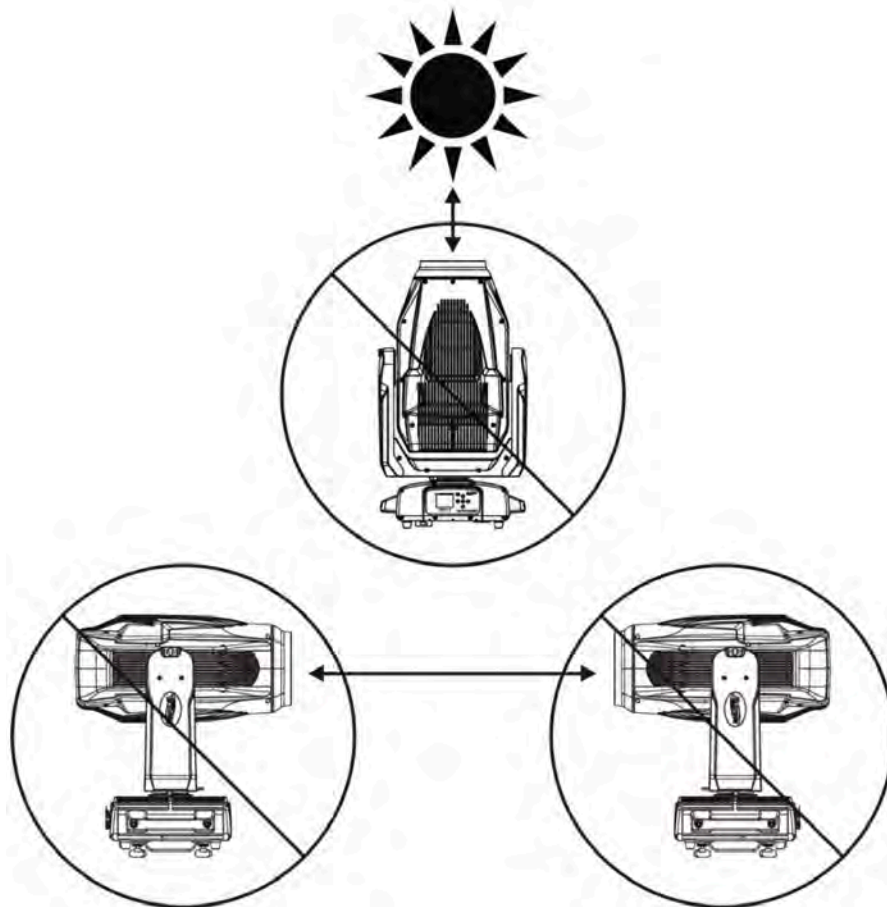

SUN PROTECTION MODE

The fixture incorporates an automatic protection from harmful sunlight, which can damage a fixture's internal components from extended exposure. Fixtures use an internal sensor to determine their physical orientation, then reorient the fixture towards the ground to prevent sunlight from entering the lens.

This automatic feature only works when the fixture is powered. If the fixture is unpowered during setup, it is necessary to manually reorient the lenses away from the sun and aim them towards the ground. Even a few minutes of sun exposure can cause damage inside the fixture.

The Sun Protection setting is accessed via the "No DMX Status" menu.

The automatic sun protection positioning is activated under the following conditions:

1. Power on without DMX signal: the fixture always starts in sun protection mode.
2. No DMX Status "Sun Protection": the fixture enters sun protection mode after approximately 3 minutes.
3. Remote DMX control: the sun protection position can be temporarily activated from the lighting console without the need to create a custom position preset. The fixture senses the correct ground orientation. This means that fixtures already facing the ground may not move their heads.

Hold "Sun Protect Position" for 3s to set the fixture to the sun protection position.

Sun protection status displays as "**Sun Protection: Active**".

The sun protection position deactivates under the following conditions:

1. Connect DMX signal.
2. Remote DMX control: Hold "Sun Protection Off" for 3s.

To avoid harsh or jarring movements, the sun protection position always uses a 5-second fade time when it is activated or deactivated.

HIBERNATION MODE

To reduce wear on the fixture and its components, this mode disables motors and most electronics. Set the hibernation mode countdown time in the Display Menu: "Status Settings / Personality / Hibernation". Hibernation can be fully disabled.

The hibernation mode activates under the following conditions:

1. Loss of DMX: the fixture enters hibernation after the timeout expires. Default is 15 minutes.
2. Remote DMX control: Hold "Hibernate Fixture" for 3s

The hibernation mode deactivates under the following conditions:

1. Connect DMX Signal
2. Remote DMX control: Hold "Hibernate Off" for 3s

The fixture will perform a full calibration cycle, then assume the current DMX status.

Please note that the Hibernation does not change the PT position of the fixtures, allowing the user to set the desired position and then issue the Hibernate command.

To ensure the fixture is protected from harmful sunrays it is recommended to either leave the "No DMX Status" in "Sun Protection" (so the fixture is already in the correct position after 3 minutes of DMX loss) or set the fixture to a safe Tilt position manually first before hibernation.

Burn and heat damage to the fixture's interior components due to external light sources (sun or other fixtures shining into the lens) is never covered under the manufacturer's warranty.

SYSTEM MENU

The fixture includes an easy to navigate system menu. The control panel (see image below) located on the front of the fixture, provides access to the main system menu and is where all necessary system adjustments are made to the fixture. During normal operation, pressing **MODE/ESC** button once will access the fixture's main menu. Once in the main menu you can navigate through the different functions and access the sub-menus with the **UP, DOWN, RIGHT, and LEFT** buttons. Once you reach a field that requires adjusting, press the **ENTER** button to activate that field and use the **UP** and **DOWN** buttons to adjust the field. Pressing the **ENTER** button once more will confirm your setting. You may exit the main menu at any time without making any adjustments by pressing the **MODE/ESC** button.

To access the LCD Menu Control Display via the internal battery, press and hold the **MODE/ESC** button for 10 seconds. The LCD Menu Control Display will shut **OFF** automatically about 1 minute from the last button press.

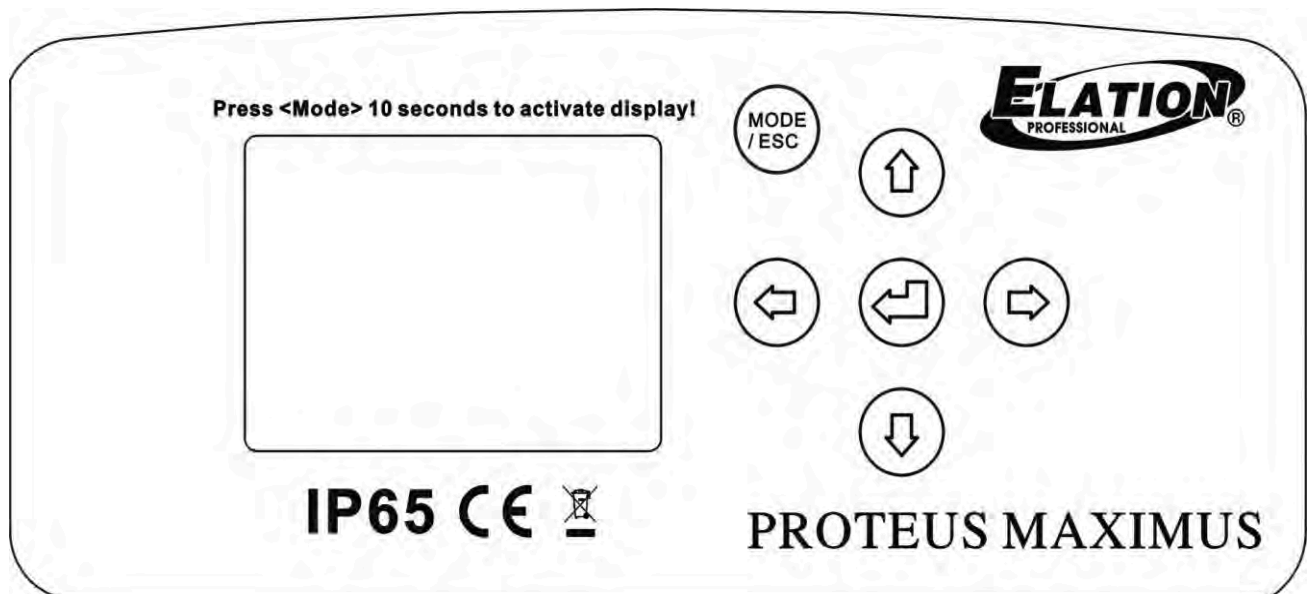

ALTHOUGH E-FLY SETTINGS MAY APPEAR IN THE SYSTEM MENU, THIS FEATURE IS NOT ACTIVATED. E-FLY WIRELESS DMX IS AN OPTIONAL FEATURE WHICH MUST BE ACTIVATED IN THE SERVICE MENU. PLEASE CONTACT ELATION SERVICE FOR FURTHER DETAILS.

AN ELATION E-LOADER III CAN BE USED TO UPDATE THE FIXTURE TO THE LATEST SOFTWARE. TO ORDER THIS DEVICE, PLEASE CONTACT ELATION SUPPORT FOR FURTHER DETAILS.

ELATION SERVICE USA - Monday - Friday 8:00am to 4:30pm PST
323-582-3322 | Fax 323-832-9142 | support@elationlighting.com

ELATION SERVICE EUROPE - Monday - Friday 08:30 to 17:00 CET
+31 45 546 85 63 | Fax +31 45 546 85 96 | support@elationlighting.eu

SYSTEM MENU

Features subject to change without notice. *Rotation direction (Clockwise/Counterclockwise) and control of effects depends on head orientation and Pan/Tilt settings.				
MAIN MENU	SUB MENU	OPTIONS / VALUES (Default Settings in BOLD)		DESCRIPTION
Function	Set Dmx Address	A001~AXXX		DMX Address Setting
	Dmx Value	PAN.....		DMX Value Display
	Secondary Mode	Secondary1, Secondary2, Secondary3		Secondary Setting
	Auto Program	Primary / Alone		Auto Program
Information	Time Information	Current Time	XXXX (Hours)	Fixture Run Time From Power ON
		Total Run Time	XXXX (Hours)	Fixture Total Run Time
		Last Run Time	XXXX (Hours)	Fixture Last Run Time
		LastRun Password	Password= 038	(PSWD Required)
		Clear Last Run	ON / OFF	Clear Fixture Last Run Time
	Temperature Info	LED Temperature	XXX C° / F °	Temperature of LED Engine
		Base Temperature	XXX C° / F °	Temperature in Fixture Base
		Head Temperature	XXX C° / F °	Temperature in Fixture Head
	Humidity Info	Base Humidity	XXX%	Humidity in Base
		Head Humidity	XXX%	Humidity in Head
	Ethernet IP	XXX. XXX. XXX. XXX	XXX. XXX. XXX. XXX	Displays Fixture Ethernet Address
	Fan Info	HeadFan: xxxx RPM		Displays Fan Info
	Software Version	Vx.x.x		Software Version
	Error Info	Error Record 1 ~ Error Record 10		Fixture Last 10 Error Codes
Personality	Status Settings	Address via DMX	ON/OFF	Address Via DMX
		No DMX Status	Close/Hold/Auto/ SunProt	Fixture State When NO DMX Signal
		Pan Reverse	ON/OFF	Pan Reverse Movement
		Tilt Reverse	ON/OFF	Tilt Reverse Movement
		Pan Degree	630/ 540	Pan Degree Select
		Feedback	ON/OFF	Movement Feedback
		Movement Speed	Normal / Slow	Movement Speed
		CMY Speed	Normal / Fast	CMY Speed
		P/T Brake Mode	Smooth / Fast	Pan/Tilt Brake Mode
	Hibernation	OFF, 01M~99M, 15M	Stand By Mode	
	Service Setting	Password	Password= 050	Service Password
		Clear Err. Info	ON/OFF	Clear Error Info (PSWD Required)
	Fans Control	Auto , High, Silent		Select Fan Speeds
	Display Setting	Shutoff Time	02~60m 05m	Display Shut Off Time
		Display Reverse	ON/OFF/ AUTO	Display Reverse 180°
		Key Lock	ON/OFF	Key Lock
	Temperature C/F	Celsius/Fahren		Temperature Switch Between C°/ F°
	Initial Status	Control =XXX		Initial Effect Position
	Select Signal	DMX Only		Select signal source
		ArtNet		
		sACN		
	Ethernet IP	XXX . XXX . XXX . XXX		Ethernet IP (PSWD Required)
	Ether Mask IP	XXX . XXX . XXX . XXX		Ethernet Mask IP (PSWD Required)
	Set Universe	000 - 32767		Set ArtNet Universe
	DHCP	ON/OFF		Setup automatic IP address assignment

SYSTEM MENU

Features subject to change without notice. *Rotation direction (Clockwise/Counterclockwise) and control of effects depends on head orientation and Pan/Tilt settings.					
MAIN MENU	SUB MENU	OPTIONS / VALUES (Default Settings in BOLD)		DESCRIPTION	
Personality	Dimmer Mode	Standard , Stage, TV, Architectural, Theatre, Stage2, Delay: 0s, 0.1s, 0.2s, ...10s		Set Dimmer Mode	
	Refresh	1200 , 900-1500, 2500, 4000, 5000, 6000 10000, 15000, 20000, 25000 (Hz)		Set LED Refresh Rate	
	Dimmer Curve	Linear , Square, Inverse Square, S-Curve		Set Dimmer Curve Mode	
	Reset Default	ON/OFF	Passcode= 011	Restore Factory Settings (PSWD Required)	
Reset Function	Reset All			Reset All Motors	
	Reset Pan&Tilt			Reset Pan/Tilt	
	Reset Colors			Reset Colors	
	Reset Gobos			Reset Gobos	
	Reset ZoomModules			Reset Zoom Modules	
	Reset Others			Reset Other Motors	
Effect Adjust	Test Channel	PAN		Test function	
	Manual Control	PAN =XXX,		Fine Adjustments	
	Calibration	Calibration Password Pan = xxx ...		Password 050 (PSWD Required)	
User Mode Set	User Mode	Standard		DMX Channel Modes	
		Extended			
Edit Program	Select Program	Auto Pro Part1 = Program 1~10 (Program 1)		Select Programs To Be Run	
		Auto Pro Part2 = Program 1~10 (Program 1)			
		Auto Pro Part3 = Program 1~10 (Program 1)			
	Edit Program	Program 1	Program Test		Testing Program
		:	Step 01=SCxxx		Program In Loop
		Program 10	Step 64=SCxxx		Save and Exit
	Edit Scenes	Edit Scene 001 ~ Edit Scene 250	Pan, Tilt,.....		Save and Automatically Return
			--Fade Time-- --Scene Time--		Manual Scenes Edit
Input By Out			Stores Scenes via Ext DMX Console		
Rec. Controller	XX~XX			Automatic Scenes Recorder	



ALTHOUGH E-FLY SETTINGS MAY APPEAR IN THE SYSTEM MENU, THIS FEATURE IS NOT ACTIVATED. E-FLY WIRELESS DMX IS AN OPTIONAL FEATURE WHICH MUST BE ACTIVATED IN THE SERVICE MENU. PLEASE CONTACT ELATION SERVICE FOR FURTHER DETAILS.

SYSTEM MENU

PERSONALITY - Status Settings - Address Via DMX

When ON, define the desired DMX address via an external controller.

NOTE: This process assumes the fixture DMX address is set to 001. If fixture DMX address is not at 001, you must adjust the channel numbers accordingly in order for this feature to work.

For example: if your fixture address is 010, then Channel 1 becomes Channel 10, Channel 2 becomes Channel 11, and Channel 3 becomes Channel 12.

1. Connect the fixture to the external controller and power ON.
2. Set the DMX value of **Channel 1** on the controller to **(7)**.
3. Set the DMX value of **Channel 2** on the controller to **(7)** or **(8)**.
When set to **(7)**, the DMX address can be set between **(1)** and **(255)**.
When set to **(8)**, the DMX address can be set between **(256)** and **(511)**.
4. Using **Channel 3** on the controller set the desired DMX address of the fixture.

Example 1: If the desired DMX address is **57**, set **Channel 1** to a value of **(7)**, set **Channel 2** to a value of **(7)**, and then set **Channel 3** to a value of **(57)**.

Example 2: If the desired DMX address is **420**, set **Channel 1** to a value of **(7)**, set **Channel 2** to a value of **(8)**, and then set **Channel 3** to a value of **(164)**. (256+164=420)

5. After setting **Channel 3** to the desired DMX address value, wait for approximately 20 seconds (some fixtures may require a longer time) for the fixture to complete the address reset function.

PERSONALITY – Service Setting - Password (050)

The Service Password MUST be entered in order to access the service menus.

SYSTEM MENU

PERSONALITY - Display Setting – Key Lock

When ON, Control Panel buttons lock automatically after exiting main menu for 15 seconds. To unlock, keep **MODE/ESC** button pressed for 3 seconds.

PERSONALITY - Reset Default



ONLY QUALIFIED TECHNICIANS SHOULD PERFORM THIS FUNCTION!

This function restores all fixture settings to the factory default settings. The password is **011** and must be entered each time a reset is performed.

EFFECT ADJUST – Test Channel

Auto test each individual channel function independently from the DMX control board.

EFFECT ADJUST – Manual Control

Select and manually test and fine adjust each individual channel function independently from DMX control board. This function will center PAN and TILT motors and set dimmer to 100%. PAN and TILT functions will still operate if the fixture needs to be positioned to a flat clear surface. With the individual functions, you can focus the light on a flat surface (wall) and perform fine adjustments.

EFFECT ADJUST – Calibration



ONLY QUALIFIED TECHNICIANS SHOULD PERFORM THIS FUNCTION!

This function allows small adjustments to be made to the Pan, Tilt, and Zoom movements to compensate for wear or in the event a sensor has been knocked slightly out of place. Because improper use of this function can result in undesired operation this function has been password protected. The password is **050** and must be entered each time the calibration menu function is entered. Because calibration is an extremely delicate procedure, instructions on performing this action are left out of this manual. For a first-time calibrator, please contact our customer support team for step-by-step instructions.

SYSTEM MENU

EDIT PROGRAM – Rec. Controller

The fixture features an integrated DMX-recorder by which you can transmit the programmed scenes from your DMX-controller to the moving head. Adjust the desired scene numbers via the encoder (from – to). When you call up the scenes at your controller, they will automatically be transmitted to the moving head.

EDIT PROGRAM – Record Controller – Working with Built-In Programs

A Primary unit can send up to 3 different data groups to the Secondary units, i.e. a Primary unit can start 3 different Secondary units, which run 3 different programs. The Primary unit sends the 3 program parts in a continuous loop.

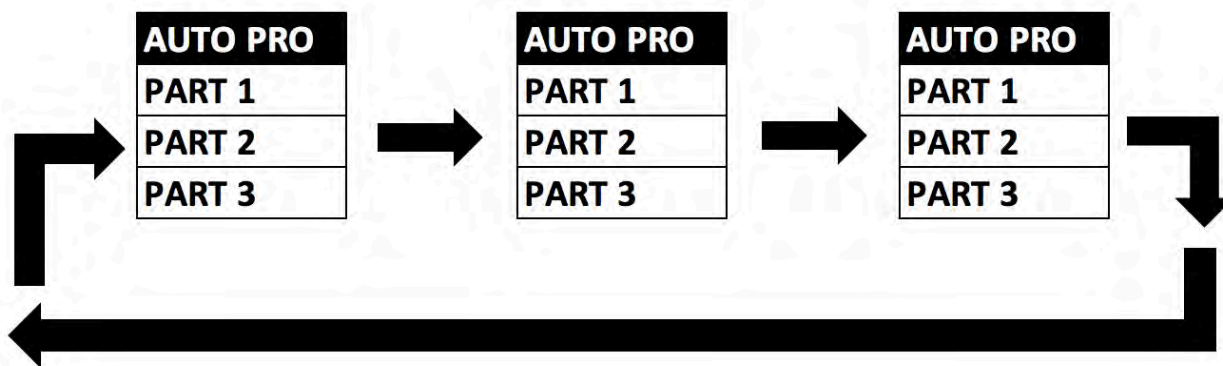

The Secondary unit receives data from the Primary unit according to the group which the Secondary unit was assigned to. If e.g. a Secondary unit is set to “**Secondary 1**” in the menu “**Set to Secondary**”, the Primary unit sends “**Auto Program Part 1**” to the Secondary unit. If set to “**Secondary 2**”, the Secondary unit receives “**Auto Program Part 2**”.

SYSTEM MENU

EDIT PROGRAM – Record Controller – Working with Built-In Program [continued]

To start an Auto Program, proceed as follows:

1. Secondary Setting

Select **“Function Mode”**.

Press **ENTER** to confirm.

Select **“Set to Secondary”**.

Press **ENTER** to confirm.

Select **“Secondary 1”**, **“Secondary 2”** or **“Secondary 3”**.

Press **ENTER** to confirm.

Press **MODE/ESC** in order to return to the main menu.

2. Automatic Program Run

Select **“Function Mode”**.

Press **ENTER** to confirm.

Select **“Auto Program”**.

Press **ENTER** to confirm.

Select **“Primary”** or **“Alone”**.

Press **ENTER** to confirm.

Press **MODE/ESC** to return to the main menu.

3. Program Selection for Auto Pro Part

Select **“Edit Program”**.

Press **ENTER** to confirm.

Select **“Select Programs”**.

Press **ENTER** to confirm.

Select **“Auto Pro Part 1”**, **“Auto Pro Part 2”** or **“Auto Pro Part 3”** and select which Secondary program is to be sent. Selection **“Part 1”** means, that the Secondary unit runs the same program as the Primary units.

Press **ENTER** to confirm.

Press **MODE/ESC** to return to the main menu.

4. Program Selection for Edit Program

Select **“Edit Program”**.

Press **ENTER** to confirm.

Select **“Edit Program”**.

Press **ENTER** to confirm.

Select the desired program to edit specific scenes into a specific program.

Press **ENTER** to confirm.

Press **MODE/ESC** to return to the main menu.

SYSTEM MENU

EDIT PROGRAM – Record Controller – Working with Built-In Program [continued]

5. Automatic Scene Recording

Select “**Edit Program**”.

Press **ENTER** to confirm.

Select “**Edit Scenes**”.

Select desired scene numbers. A maximum of 250 scenes can be programmed.

Press **ENTER** to confirm.

Press **MODE/ESC** in order to return to the main menu.

Example:

Program 2 includes scenes: 10, 11, 12, & 13

Program 4 includes scenes: 8, 9, & 10

Program 6 includes scenes: 12, 13, 14, & 15

Auto Pro Part 1 is Program 2

Auto Pro Part 2 is Program 3

Auto Pro Part 3 is Program 6

The 3 Secondary groups run the Auto Program in certain time segments. (See chart below)

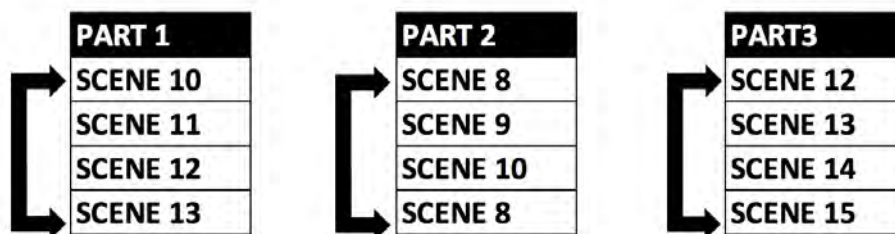

E-FLY WIRELESS DMX SETUP



BEFORE SETTING THE WIRELESS CHANNEL ON ANY E-FLY FIXTURE, MAKE SURE THE SOURCE E-FLY WIRELESS DMX TRANCEIVER DEVICE OFF.

1. Ensure the source **E-FLY** wireless DMX Transceiver device is powered **OFF**.
2. Power **ON** fixture and from the LCD control panel select **DMX & E-FLY** or **E-FLY & OUT** in the Select **Signal** sub menu of the **PERSONALITY** main system menu.
3. From the LCD control panel set the E-FLY wireless channel to the same wireless channel of the source **E-FLY** DMX Transceiver device in the **Set E-FLY Chn** sub menu of the **PERSONALITY** main system menu.

NOTE: Erratic fixture movement may occur if other **E-FLY** wireless DMX products are in use in the same area and are using the same **E-FLY** wireless channel. The fixture may immediately start to respond to the DMX wireless signal from another **E-FLY** wireless DMX Transceiver immediately when **E-FLY** is enabled. Make sure to know what **E-FLY** wireless channels are being used in the area where the fixture is being installed.

ELATION E-FLY WIRELESS TRANCEIVER has 0-14 wireless channels.

4. Set fixture DMX address in the Set Dmx Address sub menu of the **FUNCTION** main system menu.
5. The **E-FLY** signal Indicator on the fixture LCD control display will illuminate GREEN if a successful wireless DMX connection has been made or illuminate RED for NO connection. If no connection is made, repeat steps 1-4 above.
6. Repeat this process for all E-FLY compatible fixtures in the E-FLY wireless network, making sure all fixtures are assigned the same E-FLY wireless channel.
7. After all fixtures in the E-FLY wireless network have been set to the same E-FLY wireless channel and powered ON, now power ON the source E-FLY DMX Transceiver device.
8. Test all fixtures connected to the E-FLY wireless network to confirm proper functionality.

E-FLY WIRELESS INSTALLATION LOCATION GUIDELINES

There are many factors that affect and/or interrupt a wireless signal such as walls, glass, metal, objects, and people. Therefore, it is highly recommended to:

- Install devices a minimum of 9.8 ft. (3m) above audiences and/or ground level
- Adjust the wireless antenna in a vertical upright position
- Position devices in direct line of sight of the controlling E-FLY device

Careful planning and testing of the selected installation location is critical to ensure optimum and reliable wireless operation.

**9.8 ft (3m)
Above Ground**

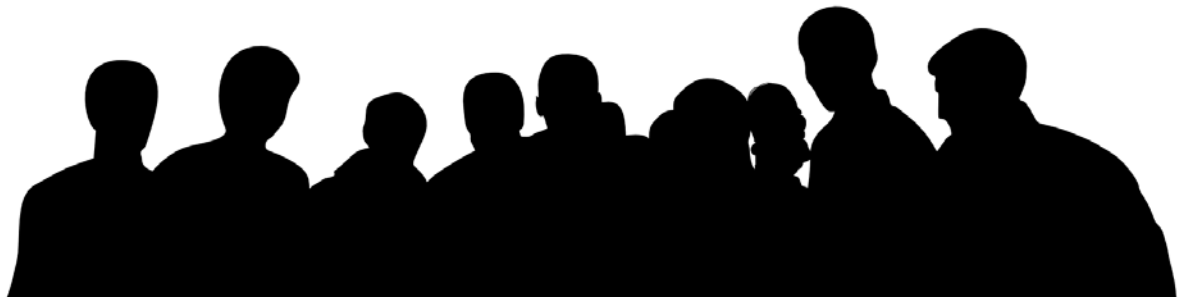

DIMMER CURVES

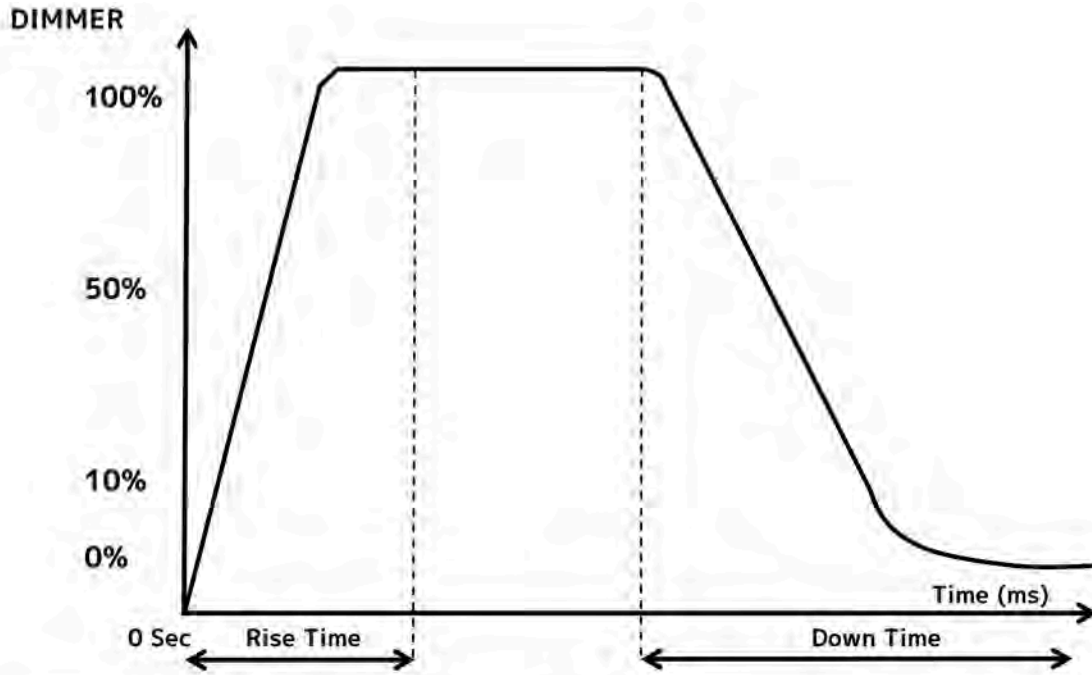

Dimming Curve Ramp Effect	0 sec Fade Time		1 sec Fade Time	
	Rise Time (ms)	Down Time (ms)	Rise Time (ms)	Down Time (ms)
Standard (default)	0	0	0	0
Stage	780	1100	1540	1660
TV	1180	1520	1860	1940
Architectural	1380	1730	2040	2120
Theatre	1580	1940	2230	2280

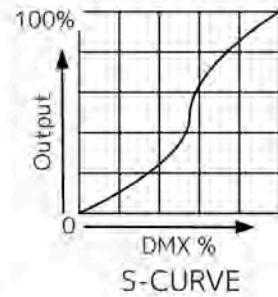
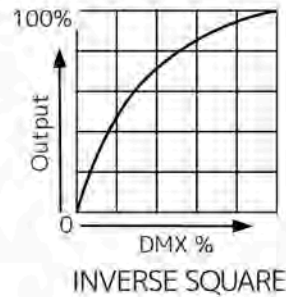
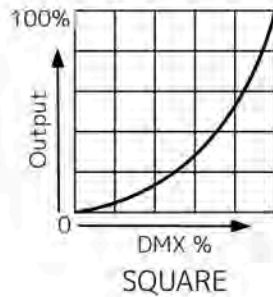
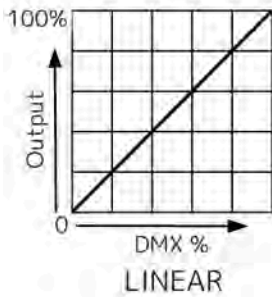

DMX CHANNEL FUNCTIONS AND VALUES

RELATION PROTEUS MAXIMUS™

DMX Channel Values / Functions (61 Total DMX Channels)

Supports Software Versions: ≥ 2.0.0

Features subject to change without notice.
*Rotation direction (Clockwise/Counterclockwise) and control of effects depends on head orientation and Pan/Tilt settings.

Standard	Extended	Value	Function	Hold Time	Default	Snap
1	1		PAN Movement 8bit:		127	
		0-255	Pan Movement			
2	2		Pan Fine 16bit:		127	
		0-255	Fine control of Pan movement			
3	3		TILT Movement 8bit:		127	
		0-255	Tilt Movement			
4	4		Tilt Fine 16bit:		127	
		0-255	Fine control of Tilt movement			
5	5		Cyan:			
		0-255	Cyan (0-100% Cyan)			
	6		Cyan Fine:			
		0-255	Cyan Fine			
6	7		Magenta:			
		0-255	Magenta (0-100% Magenta)			
	8		Magenta Fine:			
		0-255	Magenta Fine			
7	9		Yellow:			
		0-255	Yellow (0-100% Yellow)			
	10		Yellow Fine:			
		0-255	Yellow Fine			
8	11		CTO:			
		0-255	CTO (0-100% CTO)			
	12		CTO Fine:			
		0-255	CTO Fine			

Standard	Extended	Value	Function	Hold Time	Default	Snap
9	13		Color Wheel 1:			X
		0-19	Open			
		20-37	Red			
		38-55	Green			
		56-73	UV			
		74-91	HCRI			
		92-109	Orange			
		110-127	Medium Blue			
		128-189	Clockwise effect from fast to slow			
		190-193	No rotation			
		194-255	Counter-clockwise effect from slow to fast			
	14		Color Wheel Fine:			X
		0-255	Fine Control of Color Wheel position			
10	15		<u>Rotating Gobo</u>			X
		0-9	Open			
		10-19	Rot. gobo 1			
		20-29	Rot. gobo 2			
		30-39	Rot. gobo 3			
		40-49	Rot. gobo 4			
		50-59	Rot. gobo 5			
		60-69	Rot. gobo 6			
		70-89	Gobo 1 shake slow to fast			
		90-109	Gobo 2 shake slow to fast			
		110-129	Gobo 3 shake slow to fast			
		130-149	Gobo 4 shake slow to fast			
		150-169	Gobo 5 shake slow to fast			
		170-189	Gobo 6 shake slow to fast			
		190-221	Scroll CW fast to slow			
222-223	Stop					
224-255	Scroll CCW slow to fast					
11	16		Rotating Gobo Index, Rotation			
		0-127	Gobo indexing			
		128-189	Clockwise gobo scroll from fast to slow			
		190-193	No rotation			
		194-255	Counter-clockwise gobo scroll from slow to fast			
12	17		Rotating gobo fine indexing:			
		0-255	Fine indexing			

Standard	Extended	Value	Function	Hold Time	Default	Snap
13	18		Fixed gobo			X
		0-9	Open			
		10-19	Gobo 1			
		20-29	Gobo 2			
		30-39	Gobo 3			
		40-49	Gobo 4			
		50-59	Gobo 5			
		60-69	Gobo 6			
		70-77	Gobo 7			
		78-93	Gobo 1 shake slow to fast			
		94-109	Gobo 2 shake slow to fast			
		110-125	Gobo 3 shake slow to fast			
		126-141	Gobo 4 shake slow to fast			
		142-157	Gobo 5 shake slow to fast			
		158-173	Gobo 6 shake slow to fast			
		174-189	Gobo 7 shake slow to fast			
		190-221	Clockwise gobo scroll from fast to slow			
		222-223	No rotation			
224-255	Counter-clockwise gobo scroll from slow to fast					
	19		Fixed gobo indexing Fine:			X
		0-255	Fine indexing			
14	20		Rotating prism,Prism/Gobo macros:			X
		0-63	Open			
		64-95	4 Prism			
		96-127	Beam Shaper			
		128-135	Macro1			
		136-143	Macro2			
		144-151	Macro3			
		152-159	Macro4			
		160-167	Macro5			
		168-175	Macro6			
		176-183	Macro7			
		184-191	Macro8			
		192--199	Macro9			
		200-207	Macro10			
		208-215	Macro11			
		216-223	Macro12			
		224-231	Macro13			
		232-239	Macro14			
240-247	Macro15					
248-255	Macro16					

Standard	Extended	Value	Function	Hold Time	Default	Snap
15	21		Rotating prism index, rotating gobo rotation:			
		0-127	Prism indexing			
		128-189	Clockwise prism rotation from fast to slow			
		190-193	No rotation			
		194-255	Counter-clockwise prism rotation from slow to fast			
	22		Rotating prism indexing Fine :			
		0-255	Fine indexing			
16	23		Focus:		127	
		0-255	Focus edge adjustment			
17	24		Focus Fine:		127	
		0-255	Focus adjustment Fine			
18	25		Zoom:		127	
		0-255	Zoom adjustment from small to big			
19	26		Zoom Fine:		127	
		0-255	Zoom adjustment Fine			
	27		Auto Focus :			X
		0-50	Auto Focus Off			
		51-100	5m			
		101-150	7.5m			
		151-200	10m			
		201-255	15m			
	28		AutoFocus Fine:			
		0-255	Continuous adjustment Fine			
20	29		Shutter, strobe:		50	
		0-31	Shutter closed			
		32-63	No function (shutter open)			
		64-95	Strobe effect slow to fast			
		96-127	No function (shutter open)			
		128-159	Pulse-effect in sequences			
		160-191	No function (shutter open)			
		192-223	Random strobe effect slow to fast			
224-255	No function (shutter open)					
21	30		Dimmer:			
		0-255	Intensity 0 to 100%			
22	31		Dimmer Fine:			
		0-255	Dimmer fine			

Standard	Extended	Value	Function	Hold Time	Default	Snap
23	32		Dim Modes	0s		X
		0-20	Standard			
		21-40	Stage			
		41-60	TV			
		61-80	Architectural			
		81-100	Theatre			
		101- 120	Stage 2			
			Dimmer Delay Time			
		121	0s			
		122	0.1s			
		123	0.2s			
		124	0.3s			
		125	0.4s			
		126	0.5s			
		127	0.6s			
		128	0.7s			
		129	0.8s			
		130	0.9s			
		131	1.0s			
		132	1.5s			
		133	2.0s			
		134	3.0s			
		135	4.0s			
		136	5.0s			
		137	6.0s			
		138	7.0s			
139	8.0s					
140	9.0s					
141	10s					
142 - 255	Idle					

Standard	Extended	Value	Function	Hold Time	Default	Snap
24	33		Iris:			
		0-191	Max. diameter to Min.diameter			
		192-223	Pulse opening fast to slow			
		224-255	Pulse closing slow to fast			
	34		Iris Fine:			
		0-255	Iris Fine			
25	35		Frost			
		0-127	Open to Light Frost			
		128-255	Open to Wash Frost			
26	36		Animation wheel:			
		0-7	Open			
		8-255	Animation min to max			
27	37		Animation index, animation rotation:			
		0-127	Animation indexing			
		128-189	Clockwise animation rotation from fast to slow			
		190-193	No rotation			
		194-255	Counter-clockwise animation rotation from slow to fast			
	38		Speed Of CMY & Color macro Speed:			
		0-255	Speed Max →Min			

Standard	Extended	Value	Function	Hold Time	Default	Snap
			Color macros - CMY and colour wheel:			
		0-31	OFF			
		32-39	Macro1			
		40-47	Macro2			
		48-55	Macro3			
		56-63	Macro4			
		64-71	Macro5			
		72-79	Macro6			
		80-87	Macro7			
		88-95	Macro8			
		96-103	Macro9			
		104-111	Macro10			
		112-119	Macro11			
		120-127	Macro12			
		128-135	Macro13			
	39	136-143	Macro14			X
		144-151	Macro15			
		152-159	Macro16			
		160-167	Macro17			
		168-175	Macro18			
		176-183	Macro19			
		184-191	Macro20			
		192-199	Macro21			
		200-207	Macro22			
		208-215	Macro23			
		216-223	Macro24			
		224-231	Macro25			
		232-239	Macro26			
		240-247	Macro27			
		248-255	Random CMY			

Standard	Extended	Value	Function	Hold Time	Default	Snap
28	40		Blade 1A			
		0-255	Open to Close			
	41		Blade 1A Fine			
		0-255	Open to Close Fine			
29	42		Blade 1B			
		0-255	Open to Close			
	43		Blade 1B Fine			
		0-255	Open to Close Fine			
30	44		Blade 2A			
		0-255	Open to Close			
	45		Blade 2A Fine			
		0-255	Open to Close Fine			
31	46		Blade 2B			
		0-255	Open to Close			
	47		Blade 2B Fine			
		0-255	Open to Close Fine			
32	48		Blade 3A			
		0-255	Open to Close			
	49		Blade 3A Fine			
		0-255	Open to Close Fine			
33	50		Blade 3B			
		0-255	Open to Close			
	51		Blade 3B Fine			
		0-255	Open to Close Fine			
34	52		Blade 4A			
		0-255	Open to Close			
	53		Blade 4A Fine			
		0-255	Open to Close Fine			
35	54		Blade 4B			
		0-255	Open to Close			
	55		Blade 4B Fine			
		0-255	Open to Close Fine			
36	56		Framing Rotation:			
		0-126	Min (-45 degrees)			
		127-128	Parallel (0 degrees)			
		129-255	Max (+45 degrees)			
	57		Framing Rotation Fine:			
		0-255	Framing Rotation Fine			
	58		Framing Speed:			
		0-255	Speed Max →Min			

Standard	Extended	Value	Function	Hold Time	Default	Snap
	59		Framing Macro:			
		0-7	OFF			
		8-15	Macro1			
		16-23	Macro2			
		24-31	Macro3			
		32-39	Macro4			
		40-47	Macro5			
		48-55	Macro6			
		56-63	Macro7			
		64-71	Macro8			
		72-79	Macro9			
		80-87	Macro10			
		88-95	Macro11			
		96-103	Macro12			
		104-111	Macro13			
		112-119	Macro14			
		120-127	Macro15			X
		128-135	Macro16			
		136-143	Macro17			
		144-151	Macro18			
		152-159	Macro19			
		160-167	Macro20			
		168-175	Macro21			
		176-183	Macro22			
		184-191	Macro23			
		192-199	Macro24			
		200-207	Macro25			
		208-215	Macro26			
		216-223	Macro27			
		224-231	Macro28			
		232-239	Macro29			
	240-247	Macro30				
	248-255	Macro31				
	60		Pan / Tilt Speed:			
		0-225	Max to min speed			
		226-235	Blackout by movement			X
		236-245	Blackout by all wheel changing			
		246-255	No function			

Standard	Extended	Value	Function	Hold Time	Default	Snap
37	61		Control:	0s		X
		0-19	Color change normal			
		20-29	Color change to any position			
		30-39	Color & gobo change to any position			
		40-59	Fan Mode Low			
		60-69	Fan Mode High			
		70-79	Fan Mode Auto			
		80-84	All motor reset	3s		
		85-87	Pan / Tilt reset			
		88-90	Color reset			
		91-93	Gobo reset			
		94-96	Focus and Zoom reset			
		97-99	Other motor reset			
		100-168	Refresh Rate (Hz)	1s		
		100	900			
		101	910			
		102	920			
		103	930			
		104	940			
		105	950			
		106	960			
		107	970			
		108	980			
		109	990			
		110	1000			
		111	1010			
		112	1020			
		113	1030			
		114	1040			
		115	1050			
		116	1060			
		117	1070			
118	1080					
119	1090					
120	1100					

Standard	Extended	Value	Function	Hold Time	Default	Snap
37	61	121	1110	1s		X
		122	1120			
		123	1130			
		124	1140			
		125	1150			
		126	1160			
		127	1170			
		128	1180			
		129	1190			
		130	1200			
		131	1210			
		132	1220			
		133	1230			
		134	1240			
		135	1250			
		136	1260			
		137	1270			
		138	1280			
		139	1290			
		140	1300			
		141	1310			
		142	1320			
		143	1330			
		144	1340			
		145	1350			
		146	1360			
		147	1370			
		148	1380			
149	1390					
		150	1400			

Standard	Extended	Value	Function	Hold Time	Default	Snap
37	61	151	1410	1s		
		152	1420			
		153	1430			
		154	1440			
		155	1450			
		156	1460			
		157	1470			
		158	1480			
		159	1490			
		160	1500			
		161	2500			
		162	4000			
		163	5000			
		164	6000			
		165	10000			
		166	15000			
		167	20000			
		168	25000			
		169-172	Idle	3s		
		173-174	Hibernation Off			
		175-176	Hibernation			
		177-178	Sun Protection Position			
		179-180	Sun Protection Off			
		181-190	PanTilt Smooth (default)			
		191-200	PanTilt Fast			
		201-210	Dimmer Curve Linear (default)			
		211-220	Dimmer Curve Square			
		221-230	Dimmer Curve Inverse Square			
		231-240	Dimmer Curve S-Curve			
		241	Internal program 1 (scene1~8)			
		242	Internal program 2 (scene9~16)			
		243	Internal program 3 (scene17~24)			
		244	Internal program 4 (scene25~32)			
245	Internal program 5 (scene33~40)					
246	Internal program 6 (scene41~48)					
247	Internal program 7 (scene49~56)					
248-249	Cmy Normal					
250-251	Cmy Fast (default)					
252-255	Idle					

REMOTE DEVICE MANAGEMENT (RDM)

NOTE: For RDM to work properly, RDM enabled equipment must be used throughout the entire system, including DMX data splitters and wireless systems.

Remote Device Management (RDM) is a protocol that sits on top of the DMX512 data standard for lighting, allowing the DMX systems of the device to be managed, modified, and monitored remotely (hence, remote device management). This protocol is ideal for fixtures installed in locations that are not easily accessible.

With RDM, the DMX512 system becomes bi-directional, allowing a compatible RDM enabled controller to send out a signal to devices on the wire, as well as allowing the fixture to respond (known as a GET command). The controller can then use it's SET command to modify settings that would typically have to be changed or viewed directly via the unit's display screen, including the DMX Address, DMX Channel Mode, and Temperature Sensors.

FIXTURE RDM INFORMATION:

RDM Code	DEVICE ID	Device Model ID Hexadecimal	Personality ID
22a6	c160792	60b	Standard (1) Extended (2)

Please be aware that not all RDM devices support all RDM features, and therefore it is important to check beforehand to ensure that the equipment that you are considering includes all the features that you require.

The following parameters are accessible in RDM on this device:

Sensor Definition
Sensor Value
Device Model Description
Manufacturer Label
Device Label
DMX Personality
DMX Personality Description
Device Hours
Pan Invert
Tilt Invert
Display Invert

ERROR CODES

When power is applied, the unit will automatically enter a **“Reset/Test”** mode. This mode brings all the internal motors to a home position. If there is an internal problem with one or more of the motors an error code will flash in the display in the form of **“XXEr”** where as XX will represent a function number. For example, when the display shows **“0Er”** it means there is some type of error with the Pan motor. If there are multiple errors during the start-up process they will all flash in the display. For example: if the fixtures has errors on **Channel 1, 2, and 5** all at the same time, you will see the error message **“01Er”**, **“02Er”**, and **”05Er”** flash repeated 5 times.

If an error does occur during the initial start-up procedure the fixture will self-generate a second reset signal and try to realign all the motors and correct the errors. If the error persists after a second attempt a third attempt will be made. If after a third attempt all the errors have not been corrected the fixture will make the following determinations:

3 or More Errors - The fixture cannot function properly with three or more errors therefore the fixture will place itself in a stand-by mode until subsequent repairs can be made.

Less Than 3 Errors - The fixture has less than 3 errors; therefore, most other functions will work properly. The fixture will attempt to operate normally until the errors can be correct by a technician. The errors in question will remain flashing in the display as a reminder of internal errors.

Error Codes subject to change without notice.	
ERROR CODES	DESCRIPTION
PAN Er	Movement is not located in the default position after the reset. This message will appear after a fixture reset if the magnetic-indexing circuit malfunctions (sensor failed, or magnet is missing) or there is a motor failure (defective motor or a defective motor IC drive on the main PCB). This error may also be displayed if the head/yoke was blocked during a reset function.
TILT Er	
Cyan Color Wheel Er	Movement is not located in the default position after the reset. This message will appear after a fixture reset if the magnetic-indexing circuit malfunctions (sensor failed, or magnet is missing) or there is a motor failure (defective motor or a defective motor IC drive on the main PCB).
Magenta Color Wheel Er	
Yellow Color Wheel Er	
CTO Wheel Er	
Color Wheel Er	
Focus Wheel Er	
Zoom Wheel Er	
Iris Er	
AllBladeRotation Er	
Prism1 Er	
Prism2 Er	
Prism_Rot1 Er	
Prism_Rot1 Er	
Animation Er	
AnimationRot Er	

SPECIFICATIONS

SOURCE

950W 6,500K Bright White LED Engine
30,000 Hour Average LED Life*

*May vary depending on several factors including but not limited to:
Environmental Conditions, Power/Voltage, Usage Patterns (On-Off Cycling),
Control, and Dimming.

PHOTOMETRIC DATA

50,000 Total Lumen Output
CRI 70+ (82+ with HCRI Filter)
2:1 Hotspot Ratio
Zoom Range 5.5° - 55°
Beam Angle 4.8° - 41.2°
Field Angle 6.1° - 51°

EFFECTS

Motorized Zoom (Large 180mm Front Aperture)
4 Rotating Full Blackout Framing Blades
+/-45° Framing Indexing
Full 360° Bi-Directional Animation Wheel
4-Facet and Linear Rotating Prisms
2 Variable Frost Filters (Light and Wash)
Internal Color, Framing, Prism, and Frost Macros
Motorized Iris with Variable Pulse Effects
Variable 16-bit Dimming Curve Modes
High Speed Electronic Shutter and Strobe
DMX Controllable LED Refresh Rate
Pan Angle: 540°/630°
Tilt Angle: 250°

COLOR

CMY Color Mixing
Linear CTO Color Correction
6 Dichroic Colors including High CRI Filter and UV

GOBOS

2 Gobo Wheels
6 Rotating / Indexing Interchangeable Glass Gobos
7 Static Glass Gobos

CONTROL / CONNECTIONS

2 DMX Channel Modes (37 / 61)
16-bit Pan, Tilt and Dimming Control
Motorized Focus and Auto-Focus Presets
DMX, RDM, Art-NET, sACN Protocol Support
(6) Button Touch Control Panel
Full Color 180° Reversible LCD Menu Display
Hibernation Mode (Power Save)
5pin XLR DMX In/Out
IP65 RJ45 ethernet In/Out
IP65 Locking Power Cable In
With Wired Digital Communication Network

SIZE / WEIGHT

Length: 18.0 in (458mm)
Width: 23.3 in (591mm)
Height: 32.5 in (825mm)
Weight: 117 lbs. (53kg)

ELECTRICAL

AC 120-240V 50/60Hz
Max Power Consumption 1,400W
-4°F to 113°F (-20°C to 45°C)

APPROVALS / RATINGS

CE | cETLus | IP65



**NOTE: THIS FIXTURE IS INTENDED FOR TEMPORARY
OUTDOOR USE ONLY!**

Specifications and improvements in the design of this unit and this manual are subject to change without notice.

DIMENSIONAL DRAWINGS

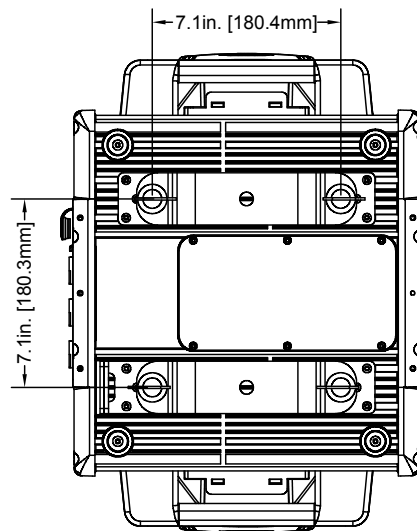
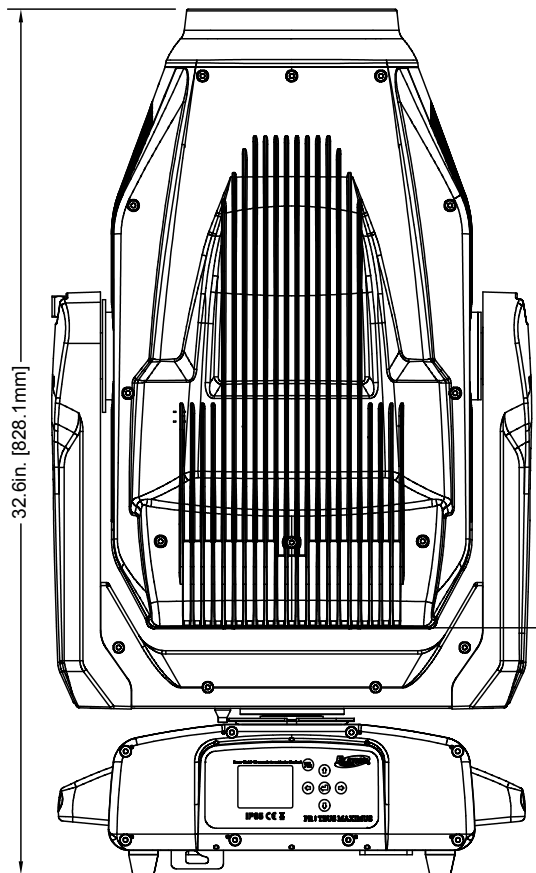
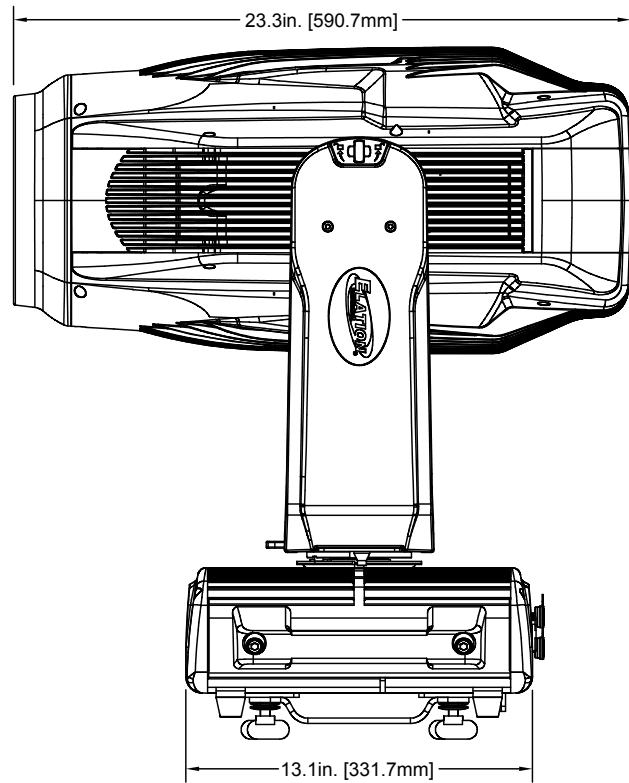
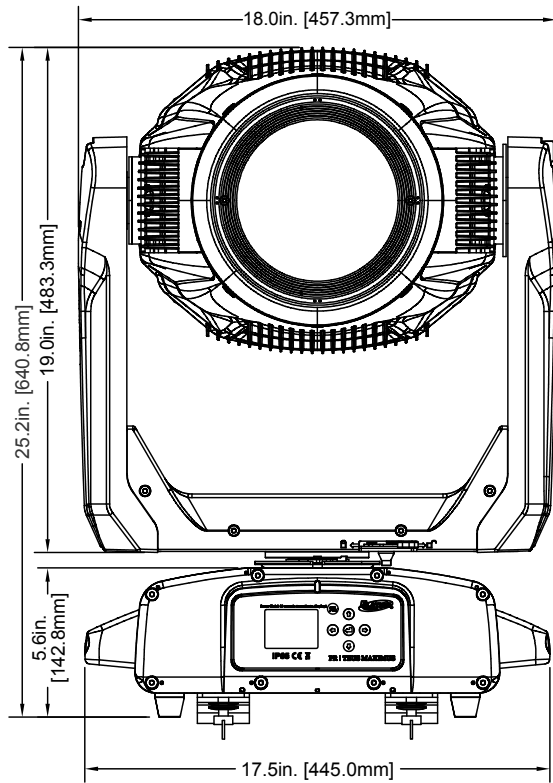

Specifications and improvements in the design of this unit and this manual are subject to change without notice.

DIMENSION DRAWINGS

Dimensions not to scale

MINIMUM CENTER-TO-CENTER FIXTURE INSTALLATION DISTANCE

To avoid damaging fixtures through moving-head radial interference impacts, a minimum center-to-center distance between fixtures must be established based on the moving-head movement arc of both fixtures, $2R+S$, where R = Moving-Head Movement Arc, and S = minimum clearance space.

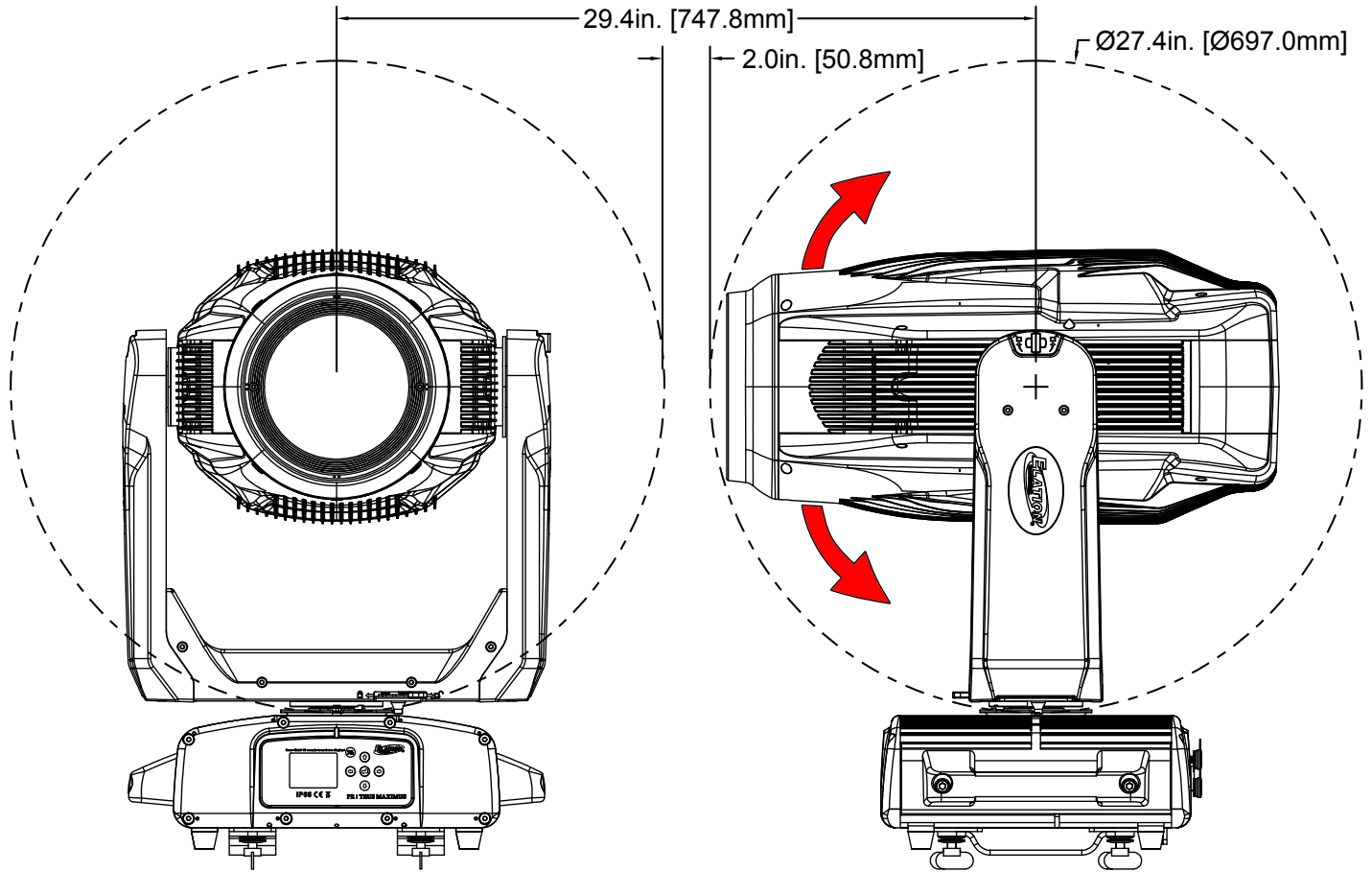

DIMENSION DRAWINGS

Dimensions not to scale

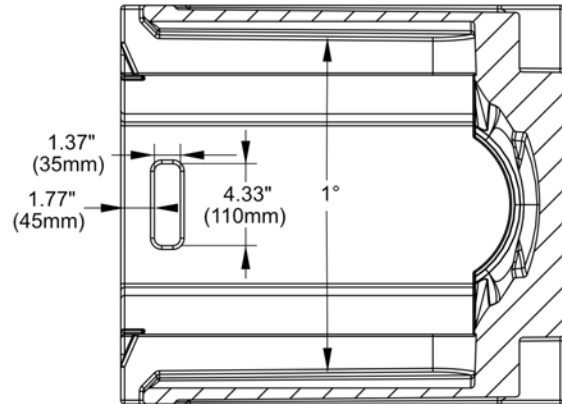
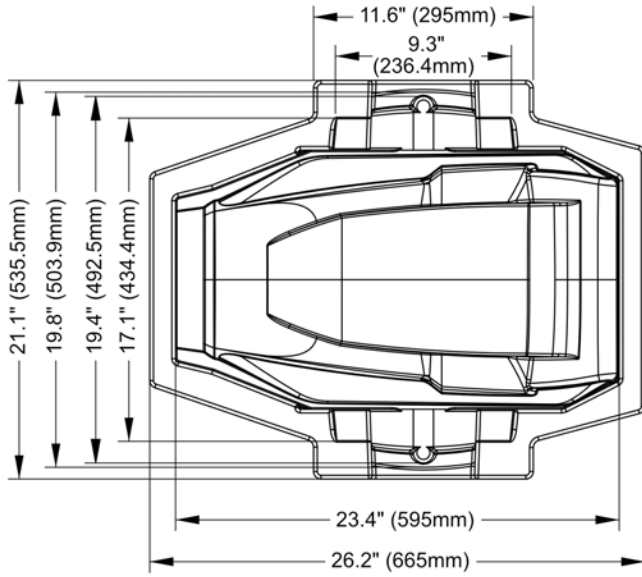

A-A

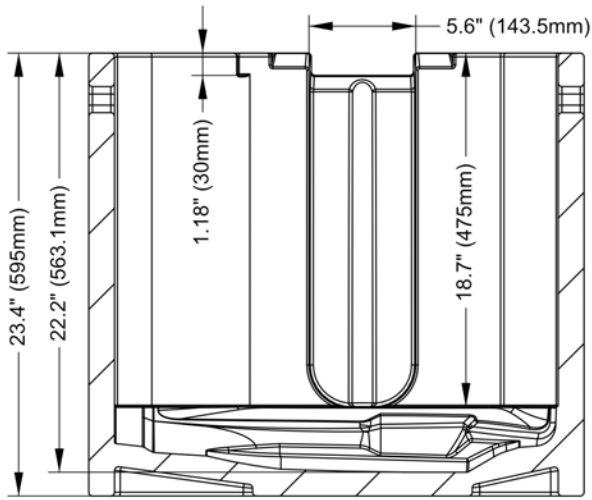

B-B

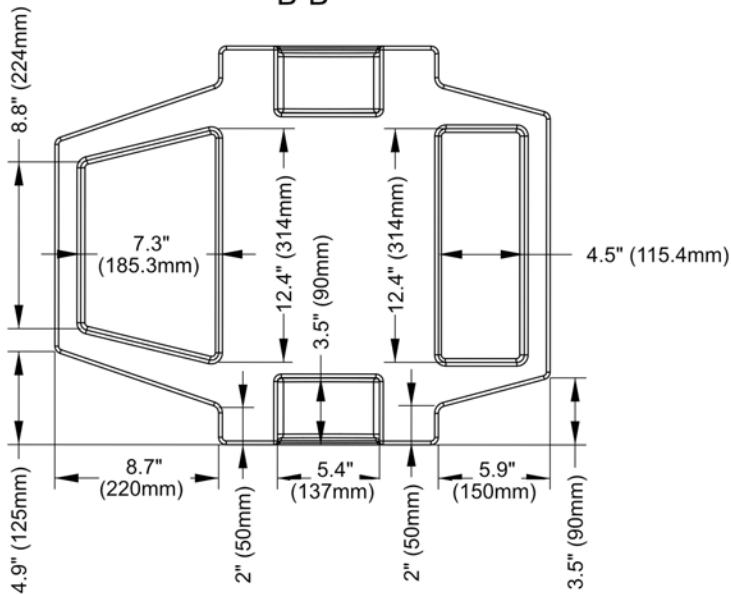
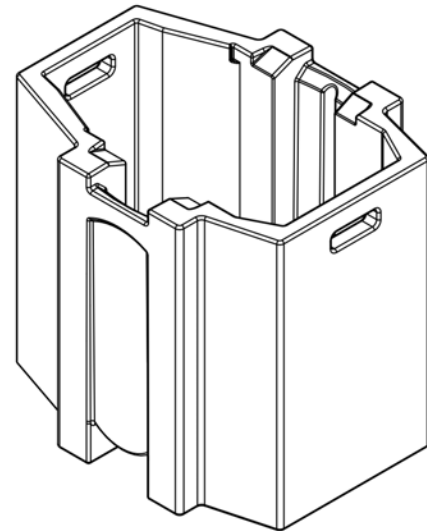

OPTIONAL ACCESSORIES

ORDER CODE	ITEM
IP TESTER	IP Fixture Vacuum and Pressure Leak Tester
TRIGGER CLAMP	Heavy Duty Wrap Around Hook Style Clamp
STR527	5 ft. (1.5m) IP65 5pin XLR Cable
	Additional Cable Lengths Available

FCC STATEMENT

This device complies with Part 15 of the FCC Rules. Operation is subject to the following two conditions: (1) this device may not cause harmful interference, and (2) this device must accept any interference received, including interference that may cause undesired operation.

FCC RADIO FREQUENCY INTERFERENCE WARNINGS & INSTRUCTIONS

This product has been tested and found to comply with the limits as per Part 15 of the FCC Rules. These limits are designed to provide reasonable protection against harmful interference in a residential installation. This device uses and can radiate radio frequency energy and, if not installed and used in accordance with the included instructions, may cause harmful interference to radio communications. However, there is no guarantee that interference will not occur in a particular installation. If this device does cause harmful interference to radio or television reception, which can be determined by turning the device off and on, the user is encouraged to try to correct the interference by one or more of the following methods:

- Reorient or relocate the device.
- Increase the separation between the device and the receiver.
- Connect the device to an electrical outlet on a circuit different from which the radio receiver is connected.
- Consult the dealer or an experienced radio/TV technician for help.

Europe Energy Saving Notice

Energy Saving Matters (EuP 2009/125/EC)

Saving electric energy is a key to help protecting the environment. Please turn off all electrical products when they are not in use. To avoid power consumption in idle mode, disconnect all electrical equipment from power when not in use. Thank you



This page intentionally left blank.

