

PIXEL DRIVER 170IP

user manual

©2023 ELATION PROFESSIONAL all rights reserved. Information, specifications, diagrams, images, and instructions herein are subject to change without notice. ELATION PROFESSIONAL logo and identifying product names and numbers herein are trademarks of ELATION PROFESSIONAL. Copyright protection claimed includes all forms and matters of copyrightable materials and information now allowed by statutory or judicial law or hereinafter granted. Product names used in this document may be trademarks or registered trademarks of their respective companies and are hereby acknowledged. All non-ELATION brands and product names are trademarks or registered trademarks of their respective companies.

ELATION PROFESSIONAL and all affiliated companies hereby disclaim any and all liabilities for property, equipment, building, and electrical damages, injuries to any persons, and direct or indirect economic loss associated with the use or reliance of any information contained within this document, and/or as a result of the improper, unsafe, insufficient and negligent assembly, installation, rigging, and operation of this product.

Elation Professional USA | 6122 S. Eastern Ave. | Los Angeles, CA. 90040

323-582-3322 | 323-832-9142 fax | www.elationlighting.com | info@elationlighting.com

Elation Professional B.V. | Junostraat 2 | 6468 EW Kerkrade, The Netherlands

+31 45 546 85 66 | +31 45 546 85 96 fax | www.elationlighting.eu | info@elationlighting.eu

Elation Professional Mexico | AV Santa Ana 30 | Parque Industrial Lerma, Lerma, Mexico 52000

+52 (728) 282-7070

DOCUMENT VERSION



Due to additional product features and/or enhancements, an updated version of this document may be available online. Please scan the QR Code with your mobile device or visit www.elationlighting.com for the latest revision/update of this manual, before installation and/or programming.

Date	Document Version	Software Version	DMX Channel Mode	Notes
01/13/23	1.0	1.01	510	Initial Release
01/30/23	1.1	N/C	No Change	Updated DMX Traits, Optional Accessories
04/05/23	1.2	N/C	No Change	Updated Specifications
05/07/24	1.3	N/C	No Change	Updated FCC Statement, ETL approved

CONTENTS

General Information	4
IP65 Rated	5
Limited Warranty	6
Safety Guidelines	7
Overview	9
Installation Instructions	10
Remote Control Operation	16
Control Panel	18
System Menu	19
DMX Traits	20
Pixel Groups	21
Color Macros	25
Maintenance Guidelines	26
Specifications	27
Dimensional Drawings	28
Optional Accessories Software Updates FCC Statement	29

GENERAL INFORMATION

INTRODUCTION

Please read and understand the instructions in this manual carefully and thoroughly before attempting to operate this device. These instructions contain important safety and use information. **This device is intended for use only by professionally trained personnel, and is not suitable for private usage.**

UNPACKING

Every device has been thoroughly tested and has been shipped in perfect operating condition. Carefully check the shipping carton for damage that may have occurred during shipping. If the carton has been damaged, carefully inspect the device for damage, and be sure all accessories necessary to install and operate the device have arrived intact. In the event that damage has been found or parts are missing, please contact our customer support team for further instructions. Please do not return this device to your dealer without first contacting customer support. Please do not discard the shipping carton in the trash. Please recycle whenever possible.

BOX CONTENTS

- UC IR24EL Remote (x1)
- Adapter Cable, 0.5m (x1)
- Omega Bracket (x1)

CUSTOMER SUPPORT

Contact ELATION Service for any product related service and support needs. Also visit forums.elationlighting.com with questions, comments, or suggestions.

ELATION SERVICE USA - Monday - Friday 8:00am to 4:30pm PST
323-582-3322 | Fax 323-832-9142 | support@elationlighting.com

ELATION SERVICE EUROPE - Monday - Friday 08:30 to 17:00 CET
+31 45 546 85 63 | Fax +31 45 546 85 96 | support@elationlighting.eu

REPLACEMENT PARTS - please visit parts.elationlighting.com



IMPORTANT NOTICE!

THERE ARE NO USER SERVICEABLE PARTS INSIDE THIS UNIT. DO NOT ATTEMPT ANY REPAIRS YOURSELF, AS DOING SO WILL VOID YOUR MANUFACTURER'S WARRANTY. DAMAGES RESULTING FROM MODIFICATIONS TO THIS FIXTURE AND/OR THE DISREGARD OF SAFETY INSTRUCTIONS AND GUIDELINES IN THIS MANUAL VOID THE MANUFACTURER'S WARRANTY AND ARE NOT SUBJECT TO ANY WARRANTY CLAIMS AND/OR REPAIRS.

IP65 RATED

The **International Protection (IP)** rating system is commonly expressed as “**IP**” (Ingress Protection) followed by two numbers (i.e. IP65), where the numbers define the degree of protection. The first digit (Foreign Bodies Protection) indicates the extent of protection against particles entering the fixture, and the second digit (Water Protection) indicates the extent of protection against water entering the fixture. An **IP65** rated lighting fixture is designed and tested to protect against the ingress of dust (**6**), and low-pressure water jets from any direction (**5**).

NOTE: THIS FIXTURE IS INTENDED FOR TEMPORARY OUTDOOR USE ONLY!

Maritime/Coastal Environment Installations: A coastal environment is seaside adjacent, and caustic to electronics through exposure to atomized salt-water and humidity, whereas maritime is anywhere within 5-miles of a coastal environment.



NOT suitable for maritime/coastal environment installations. Installing this fixture in a maritime/coastal environment may cause corrosion and/or excessive wear to the interior and/or exterior components of the fixture. Damages and/or performance issues resulting from installation in a maritime/coastal environment will void the manufactures warranty, and will NOT be subject to any warranty claims and/or repairs.

Maritime installations require additional preparation, and additional service intervals may be needed given the maritime use. In general, IP ratings presuppose freshwater conditions VS maritime conditions, which are typically more “caustic” to IP fixtures (both internally and externally). A duty-cycle may also be needed when units are not in use. During times of high humidity and colder temperatures, condensation may occur internally so the fixture may require a duty-cycle to bring it up to running temperature, allowing any accumulation of moisture to be expelled via the vent valve. Recommendations can change based on installation environmental circumstances. A waterproof dome or similar device is recommended for use in permanent outdoor installations. When using a dome, refer to manufacturer recommendations for duty-cycle.

Exterior Maintenance: Inspect the exterior every 30-days. The unit must be powered off/disconnected. The chassis should be inspected for any signs of contaminants. Inspect optics to determine if the lens is obstructed, then clean optics and chassis accordingly. Based on initial finding, schedule maintenance accordingly, keeping in mind that exterior maintenance will be required. Even if the luminaires are NOT in use, maintenance will still be needed given its location (exterior use). The use of a durable type of wax on the chassis is recommended since it will help prevent contaminant build up. Inspect both power and data lines for any signs of contaminants or corrosion. Periodically reapplying di-electric grease, especially in coastal environments. If any signs of corrosion/contaminants are present, clean thoroughly, and/or replace connectors, then reapply di-electric grease. Typically, this should be done annually, or any time an opportunity presents itself. As a preventive measure, annual replacement of both vent valves is recommended. The vent valve membrane can become contaminated and/or clogged causing improper venting of humidity within the luminaire. Inspect all mounting hardware as a precaution.

Interior Maintenance: Inspect the interior every 30-days. The unit must be powered off/disconnected.

- Inspect zoom/focus mechanism, clean optics, lubricate linear bearings (Krytox oil) as needed, inspect belts for wear
- Inspect all rotating effect wheels, manually rotate them, note any resistance
- Inspect all remaining rotating belts for any wear
- Inspect all fans, clean as needed, check rotation, check connections
- Inspect CMY module, manually move flags and check for signs of resistance, and if needed, clean guide rods first, then reapply a thin layer of grease (moly lube)
- Clean interior with low-volume compressed air, then clean optics prior to reassembly of head covers

Although the base has limited moving parts, the pan belt should also be inspected for wear. Remember to always perform an IP test anytime a cover is removed.

There is no specific time frame regarding the routine replacement of parts such as belts/stepper motors, PCBs, or LEDs. These items should only be replaced on an as needed bases, except for cooling fans, which should be replaced once the luminaries reach 10,000-hours. This is a prophylactic measure intended to keep the unit running as cool as possible, insuring proper function of all internal components. A complete service breakdown is available, please contact service@elationlighting.com for any needed parts or manuals.

LIMITED WARRANTY (USA ONLY)

- A. Elation Professional hereby warrants, to the original purchaser, Elation Professional products to be free of manufacturing defects in material and workmanship for a period of two years (730 days), and Elation Professional product rechargeable batteries to be free of manufacturing defects in material and workmanship for a period of six months (180 days), from the original date of purchase. This warranty excludes discharge lamps and all product accessories. This warranty shall be valid only if the product is purchased within the United States of America, including possessions and territories. It is the owner's responsibility to establish the date and place of purchase by acceptable evidence, at the time service is sought.
- B. For warranty service, send the product only to the Elation Professional factory. All shipping charges must be pre-paid. If the requested repairs or service (including parts replacement) are within the terms of this warranty, Elation Professional will pay return shipping charges only to a designated point within the United States. If any product is sent, it must be shipped in its original package and packaging material. No accessories should be shipped with the product. If any accessories are shipped with the product, Elation Professional shall have no liability what so ever for loss and/or or damage to any such accessories, nor for the safe return thereof.
- C. This warranty is void if the product serial number and/or labels are altered or removed; if the product is modified in any manner which Elation Professional concludes, after inspection, affects the reliability of the product; if the product has been repaired or serviced by anyone other than the Elation Professional factory unless prior written authorization was issued to purchaser by Elation Professional; if the product is damaged because not properly maintained as set forth in the product instructions, guidelines and/or user manual.
- D. This is not a service contract, and this warranty does not include any maintenance, cleaning or periodic check-up. During the periods as specified above, Elation Professional will replace defective parts at its expense, and will absorb all expenses for warranty service and repair labor by reason of defects in material or workmanship. The sole responsibility of Elation Professional under this warranty shall be limited to the repair of the product, or replacement thereof, including parts, at the sole discretion of Elation Professional. All products covered by this warranty were manufactured after January 1, 1990, and bare identifying marks to that effect.
- E. Elation Professional reserves the right to make changes in design and/or performance improvements upon its products without any obligation to include these changes in any products theretofore manufactured.
- F. No warranty, whether expressed or implied, is given or made with respect to any accessory supplied with the products described above. Except to the extent prohibited by applicable law, all implied warranties made by Elation Professional in connection with this product, including warranties of merchantability or fitness, are limited in duration to the warranty periods set forth above. And no warranties, whether expressed or implied, including warranties of merchantability or fitness, shall apply to this product after said periods have expired. The consumer's and/or dealer's sole remedy shall be such repair or replacement as is expressly provided above; and under no circumstances shall Elation Professional be liable for any loss and/or damage, direct and/or consequential, arising out of the use of, and/or the inability to use, this product.
- G. This warranty is the only written warranty applicable to Elation Professional products and supersedes all prior warranties and written descriptions of warranty terms and conditions heretofore published.

WARRANTY RETURNS

All returned service items whether under warranty or not, must be freight pre-paid and accompanied by a return authorization (R.A.) number. The R.A. number must be clearly written on the outside of the return package. A brief description of the problem, as well as the R.A. number, must also be written down on a piece of paper and included in the shipping container. If the unit is under warranty, you must provide a copy of your proof of purchase invoice. Items returned without an R.A. number clearly marked on the out-side of the package will be refused and returned at customer's expense. You may obtain an R.A. number by contacting customer support.

SAFETY GUIDELINES

This fixture is a sophisticated piece of electronic equipment. To guarantee smooth operation, it is important to follow all instructions and guidelines in this manual. Elation Professional is not responsible for injury and/or damages resulting from the misuse of this fixture due to the disregard of the information printed in this manual. Only qualified and/or certified personnel should perform installation of this fixture and only the original rigging parts included with this fixture should be used for installation. Any modifications to the fixture and/or the included mounting hardware will void the original manufacturer's warranty and increase the risk of damage and/or personal injury.



PROTECTION CLASS 1 - FIXTURE MUST BE PROPERLY GROUNDED.



THERE ARE NO USER SERVICEABLE PARTS INSIDE THIS UNIT. DO NOT ATTEMPT ANY REPAIRS YOURSELF. DOING SO WILL VOID YOUR MANUFACTURER'S WARRANTY. DAMAGES RESULTING FROM MODIFICATIONS TO THIS DEVICE AND/OR THE DISREGARD OF SAFETY INSTRUCTIONS AND GUIDELINES IN THIS MANUAL VOID THE MANUFACTURER'S WARRANTY AND ARE NOT SUBJECT TO ANY WARRANTY CLAIMS AND/OR REPAIRS.



**DO NOT PLUG THIS UNIT INTO A DIMMER PACK!
NEVER OPERATE THIS UNIT WITH THE CASING REMOVED!
DISCONNECT POWER BEFORE PERFORMING MAINTENANCE!
NEVER TOUCH DURING OPERATION, AS FIXTURE SURFACES MAY BE HOT!
KEEP FLAMMABLE MATERIALS AWAY FROM FIXTURE!**

SAFETY GUIDELINES

FOR YOUR OWN PERSONAL SAFETY, PLEASE READ AND UNDERSTAND THIS MANUAL COMPLETELY BEFORE ATTEMPTING TO INSTALL OR OPERATE THIS UNIT!

- Be sure to save the packing carton in the unlikely event that the device may need to be returned for service.
- Be sure that the voltage of the power source matches the required voltage for the device.
- **Do not** open up the device for any reason. There are no user serviceable parts inside.
- Disconnect the device's main power when left unused for long periods of time.
- **Never** connect this device to a dimmer pack.
- **Do not** attempt to operate this device if it has been damaged in any way.
- **Never** operate this device with the cover removed.
- **Do not** attempt to operate this device if the power cord has been frayed or broken.
- **Do not** attempt to remove or break off the ground prong from the electrical cord. This prong is used to reduce the risk of electrical shock and fire in case of an internal short.
- Disconnect from main power before making any type of connection.
- **Never** block the ventilation holes. Always be sure to mount this device in an area that will allow proper ventilation. Allow about 6" (15cm) between this device and a wall.
- **Always** mount this unit in a safe and stable matter.
- Please route your power cord out of the way of foot traffic. Power cords should be routed so they are not likely to be walked on, or pinched by items placed upon or against them.
- Keep flammable materials away from this fixture!
- The device should be serviced by qualified service personnel when:
 - A. The power-supply cord or the plug has been damaged.
 - B. Objects have fallen on, or liquid has been spilled into, the device.
 - C. The device has been immersed in liquid.
 - D. The appliance does not appear to operate normally or exhibits a marked change in performance.

OVERVIEW

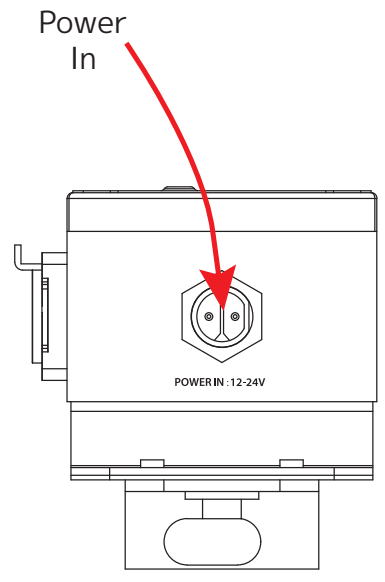
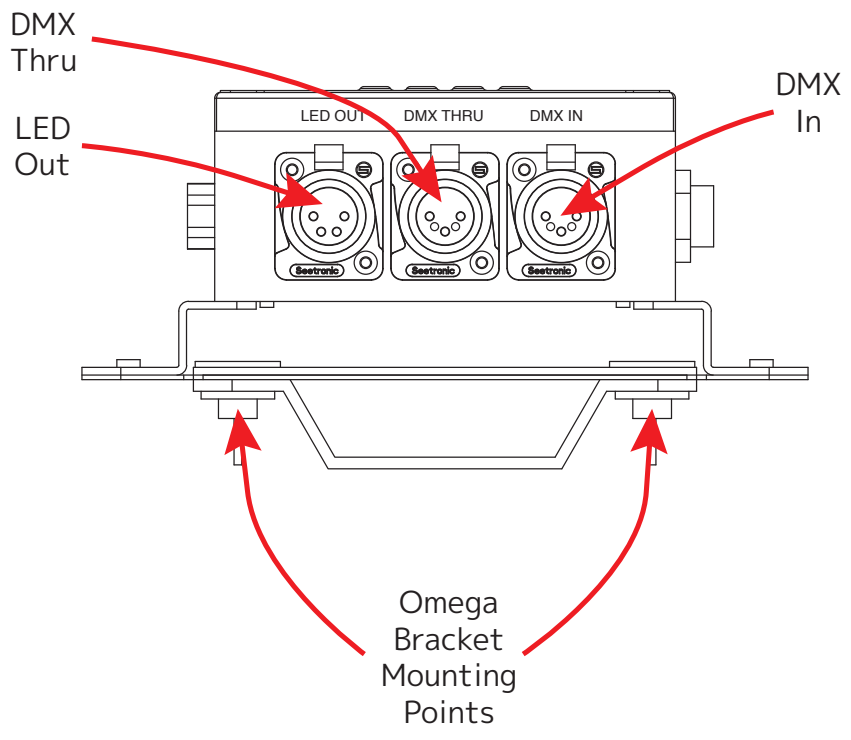
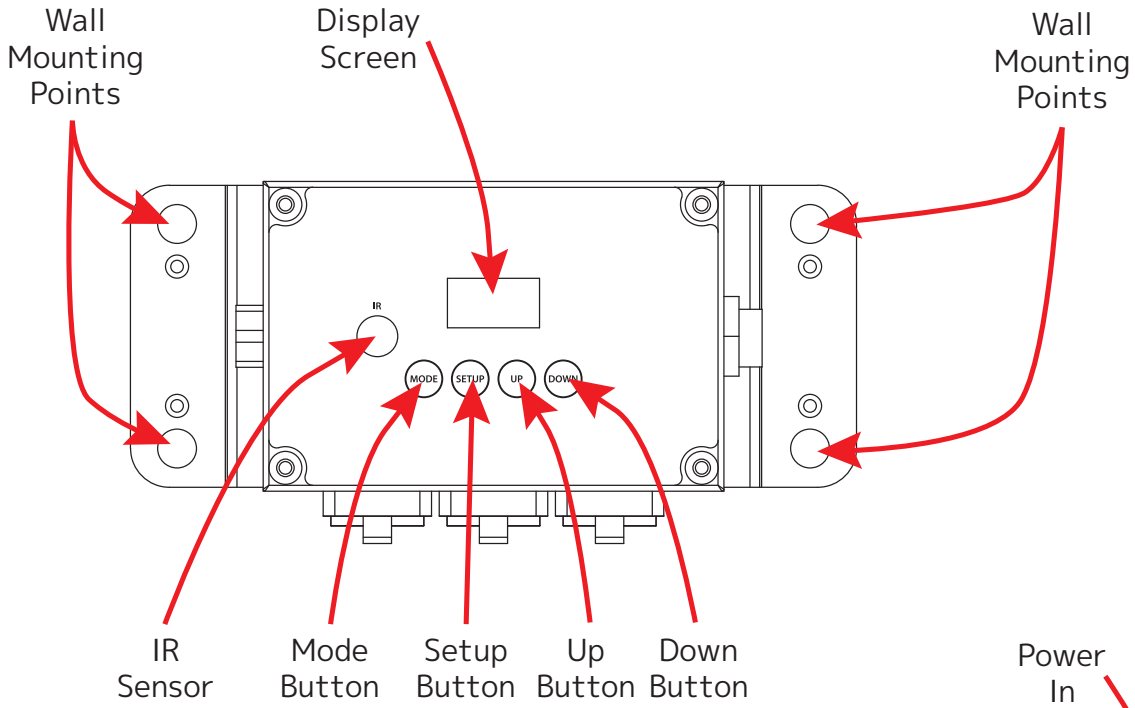

INSTALLATION GUIDELINES

FLAMMABLE MATERIAL WARNING!

Keep drive a minimum of 5.0 feet (1.5m) away from flammable material and/or pyrotechnics.

DO NOT INSTALL THE DEVICE IF YOU ARE NOT QUALIFIED TO DO SO!

- The driver **MUST** be installed following all local, national, and country commercial electrical and construction codes and regulations.
- Before installing or mounting any device, a professional equipment installer **MUST** be consulted to determine whether the mounting structure or surface is properly certified to safely support the combined weight of the device and any relevant accessories.
- The device should be installed away from walking paths, seating areas, or any areas where unauthorized personnel may potentially reach the device by hand.

CONNECTIONS (DRIVERS IN SERIES)

1. On **Driver 1**, connect the "DMX In" port to the **DMX Controller** using a 5-pin XLR cable. Connect the "LED Out" port to your LED Tape or Pixel Wash 40IPs using a 4-pin XLR cable.
2. On **Driver 1**, connect the "DMX Thru" port to the "DMX In" port of the next driver in the series (**Driver 2** in the illustration below) using a 5-pin XLR cable. This applies only if multiple drivers are being controlled by the **DMX Controller**.
3. On **Driver 2**, connect the "LED Out" port to your LED Tape or Pixel Wash 40IPs using a 4-pin XLR cable.
4. If **Driver 2** is the last driver in your series, then the "DMX Thru" port can be left disconnected, as shown in the illustration below. Alternately, if there are additional drivers in your series, the "DMX Thru" port of **Driver 2** should be connected to the "DMX In" port of the next driver.
5. Once all connections have been made, connect the "Power In" port of each driver to a suitable power source.

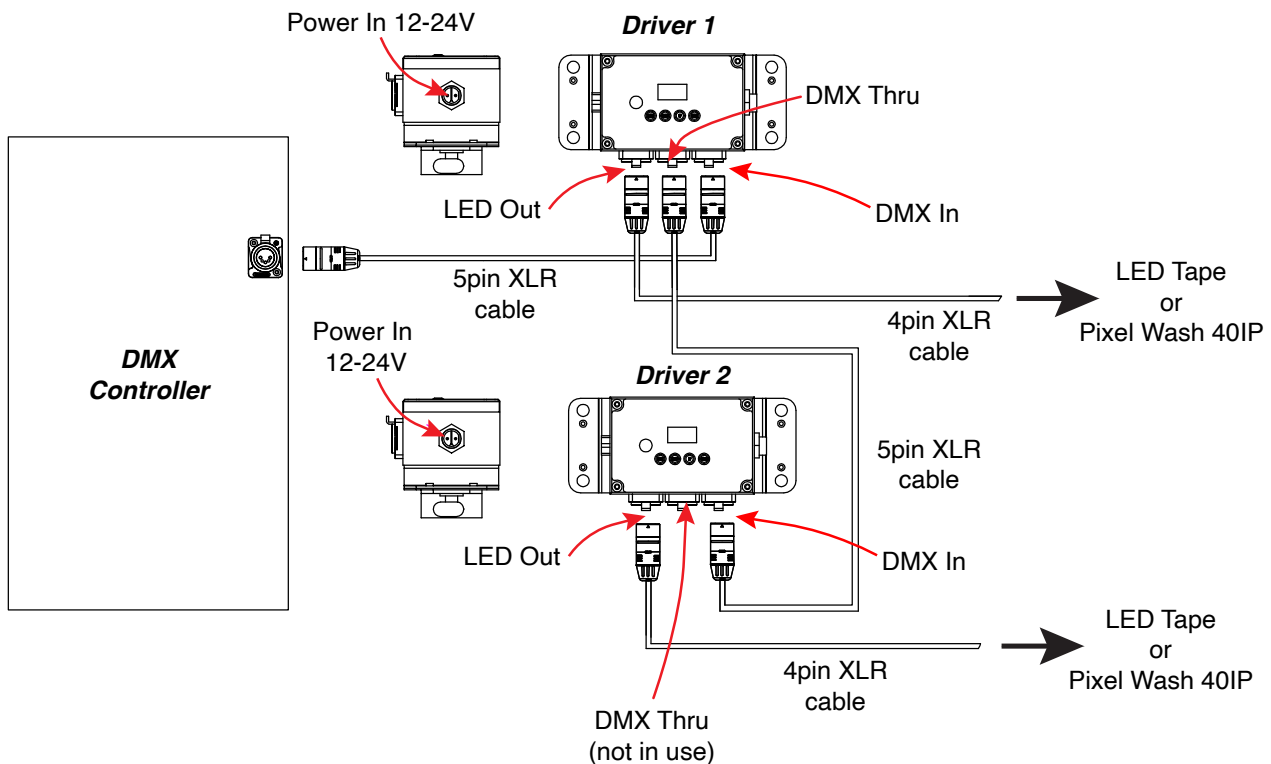

INSTALLATION GUIDELINES

CONNECTIONS (DRIVERS IN PARALLEL)

Alternately, if your DMX controller features multiple outlet ports, you can also opt to set up the drivers in parallel, with each driver receiving its own dedicated outlet on the DMX controller and no direct link between the individual drivers. Such a setup can be particularly useful for running LED Tape strips, which can require a very large number of control channels to operate.

1. On **Driver 1**, connect the “DMX In” port to the first outlet of the **DMX Controller** using a 5-pin XLR cable.
2. On **Driver 1**, connect the “LED Out” port to your LED Tape or Pixel Wash 40IPs using a 4-pin XLR cable.
3. Leave the “DMX Thru” port unconnected.
4. Repeat steps 1-3 for each additional driver in your system. Once all connections have been made, connect the “Power In” port of each driver to a suitable power source.

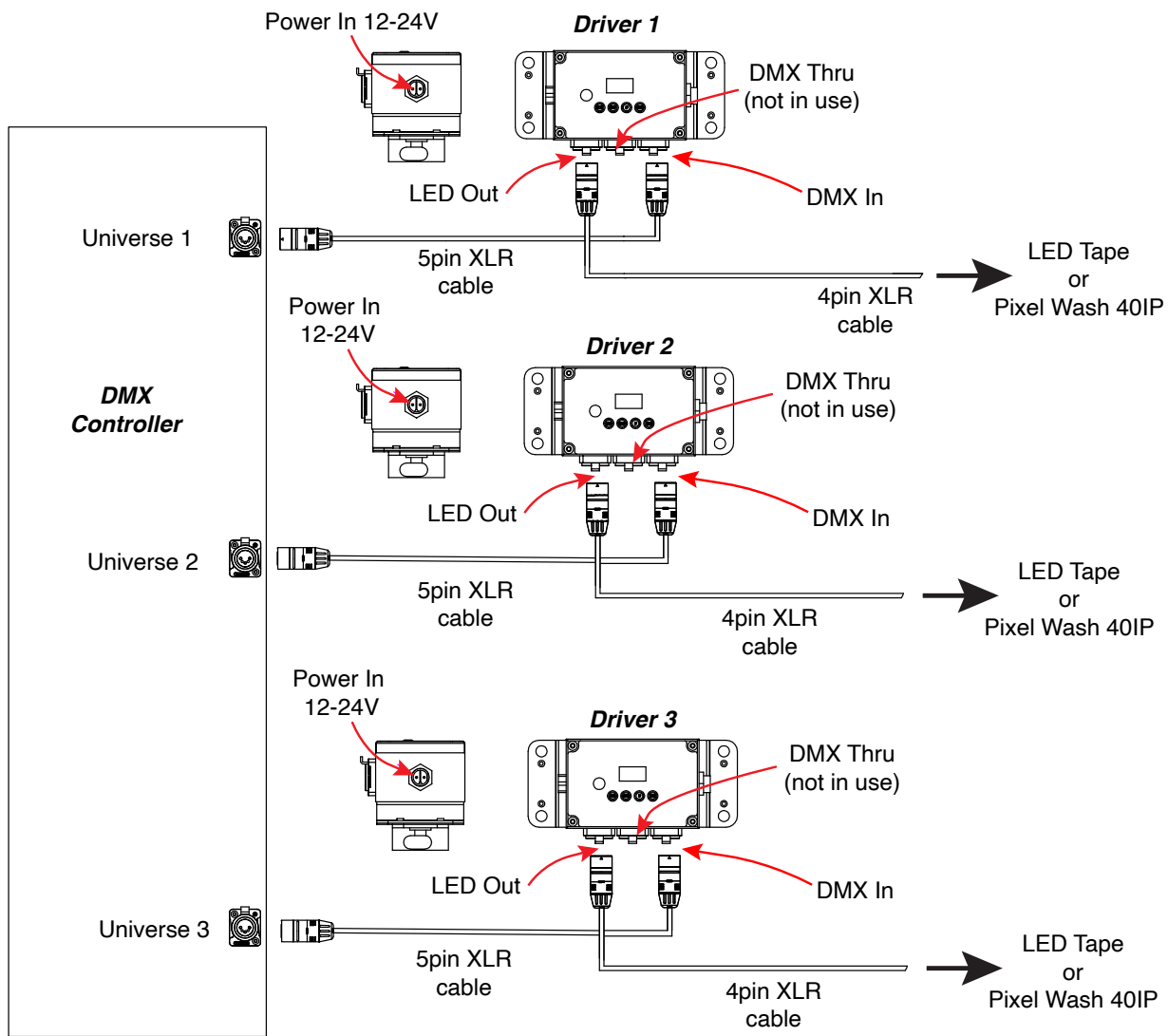

INSTALLATION GUIDELINES

HI POWER MODE

This driver features a Hi Power Mode, which can be disabled in order to allow the driver to control additional Pixel Wash 40IP fixtures. The max number of fixtures that can be controlled by the driver is as follows:

- Hi Power Mode ON: 5 fixtures max per driver
- Hi Power Mode OFF: 8 fixtures max per driver

Please note that these limitations apply only when using the driver to operate Pixel Wash 40IP fixtures. Refer to the images below.

Hi Power Mode On:

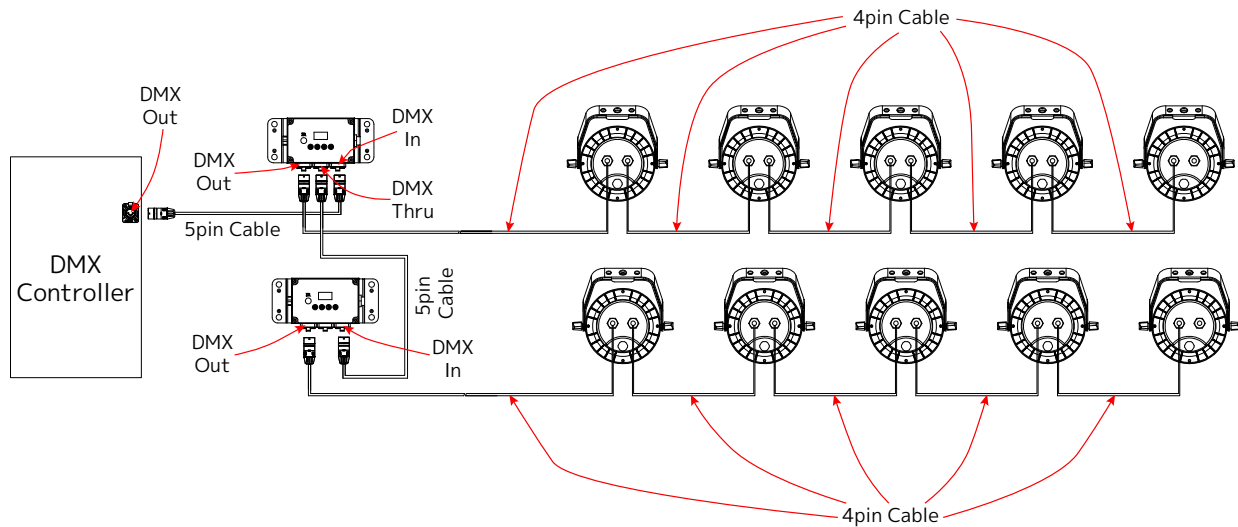

Hi Power Mode Off:

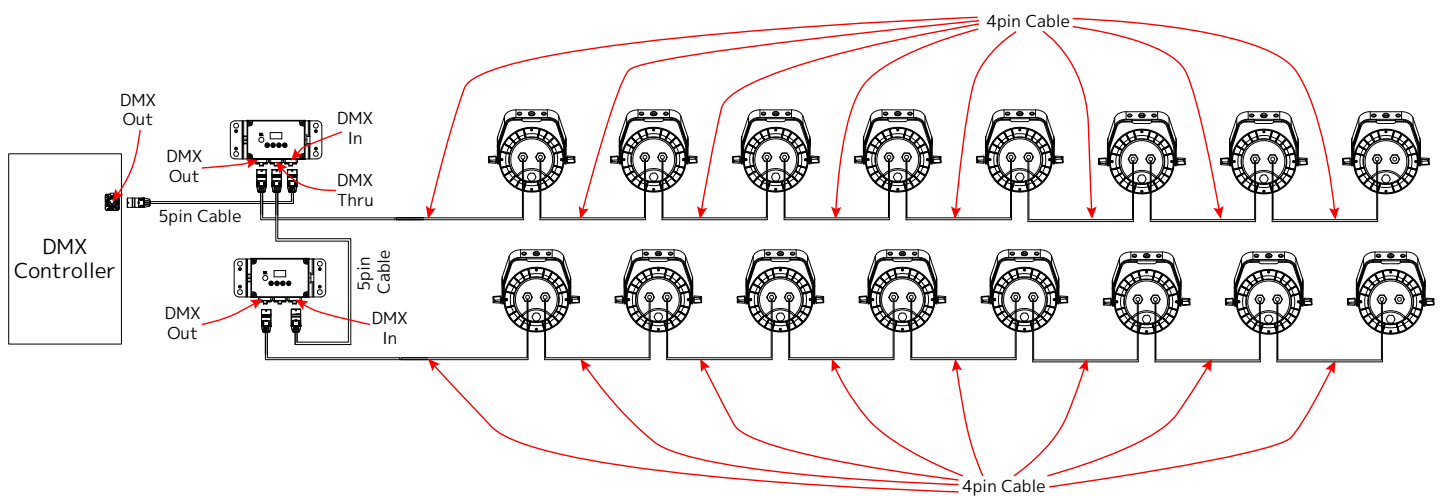

INSTALLATION GUIDELINES

PIXEL AMP 200

The Pixel Amp 200 device can be used to increase the number of Pixel Wash 40IP fixtures that can be controlled with a single driver.

1. Link the fixtures in groups, where **the maximum size of each group is 5 fixtures per group when Hi Power Mode is on, or 8 fixtures per group when Hi Power mode is off.**
2. Link the outlet port of the driver to the inlet of the first fixture of the first group.
3. Link the outlet of the last unit in the first group to the inlet of the Pixel Amp 200.
4. Link the outlet of the Pixel Amp 200 to the inlet of the first unit in the following group.
5. Repeat steps 3 and 4 until all the fixture groups are linked.

Please note that each driver can only accommodate a maximum of 5 fixture groups, regardless of whether Hi Power Mode in on or off. This translates to a maximum of 25 fixtures per driver with Hi Power Mode on (as shown below), or 40 fixtures per driver with Hi Power Mode Off. Multiple drivers can still be linked via the DMX Thru ports.

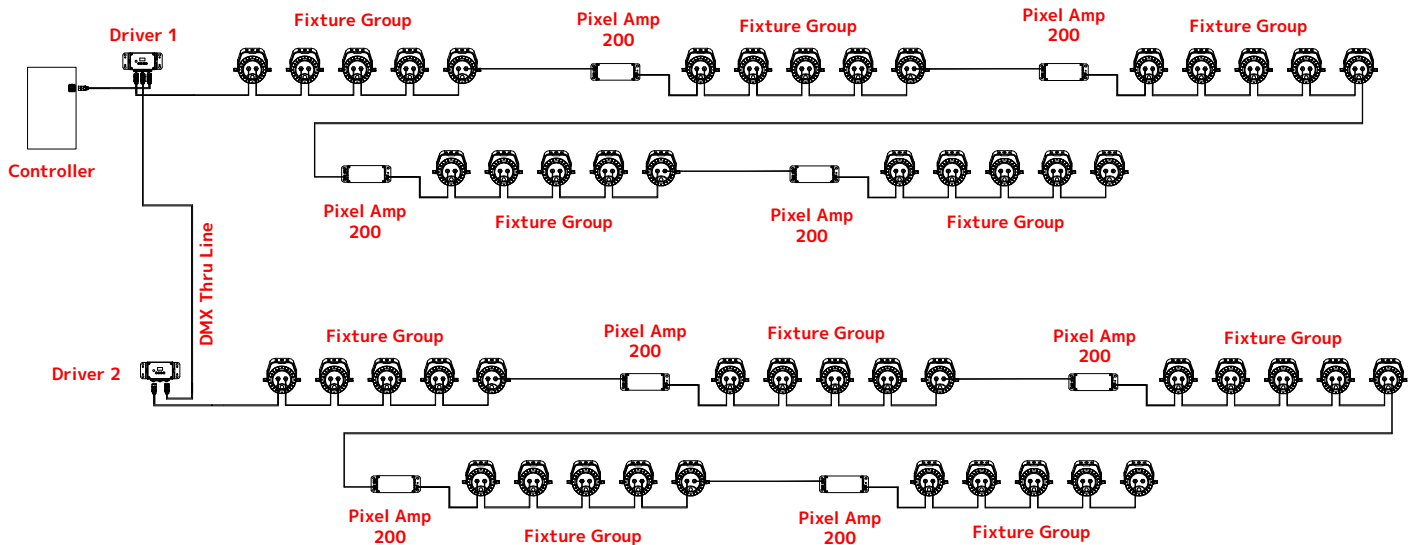

INSTALLATION INSTRUCTIONS

MAXIMUM ALLOWABLE CABLE LENGTHS FOR PIXEL WASH 40IP

Without Pixel AMP 200 (max 8 Pixel Wash 40IP units):

Pixel BCx cable* may be used to link multiple devices. Maximum allowable cable lengths are listed below.

- Max length of cable connecting a Pixel Driver 170IP and a fixture: 98feet (30m)
- Max length of cable connecting two fixtures: 98 feet (30m)
- Max total cable length in a single chain: 98 feet (30m) including the lengths of the Pixel Wash 40IP(s)

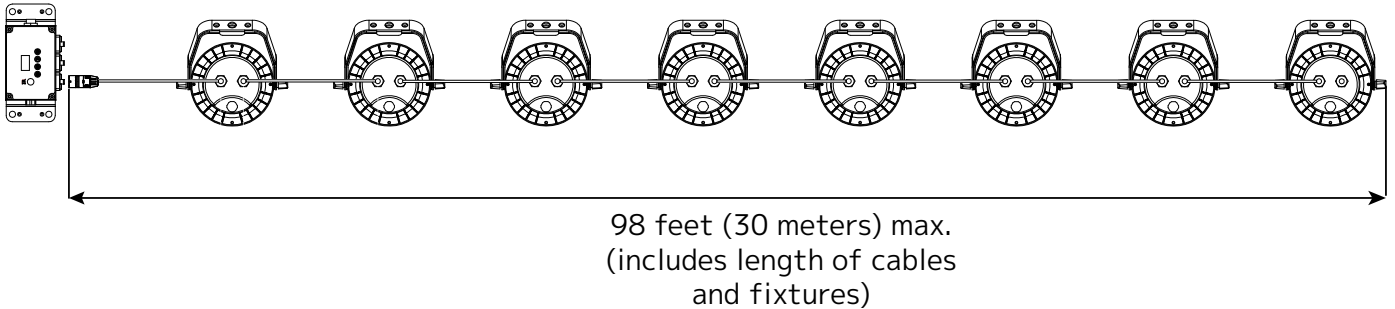

With up to 4pcs Pixel AMP 200:

Pixel BCx cable* may be used to link multiple devices. Maximum allowable cable lengths are listed below.

- Max total cable length in a single chain: 360 feet (110m) including the lengths of the Pixel Wash 40IP(s)
- Max distance from Pixel Driver 170IP to last fixture in a group: 98 ft (30m) including lengths of Pixel Driver 40IPs
- Max distance from Pixel Amp 200 to last fixture in a group: 65 ft (20m) including lengths of Pixel Driver 40IPs

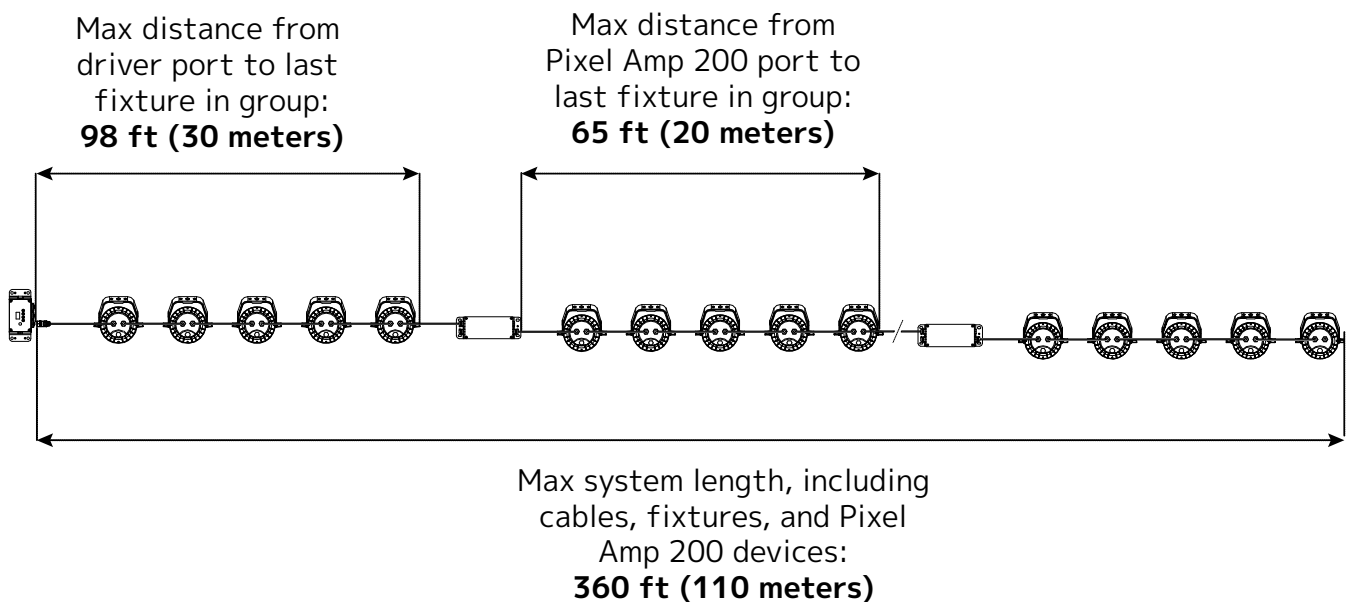

*For the Pixel BCx cable, the "x" represents the length of the cable in feet. Available lengths include 2', 3', 5', 10', 12', 15', 20', 25', 30', and 50'.

INSTALLING GUIDELINES

WALL MOUNTING

The driver includes mounting flanges for wall mount installations. Use four (4) **M6x25** self-tapping screws and insert them through the mounting holes located on the flanges. Make sure that the driver is mounted firmly and securely before proceeding to use.

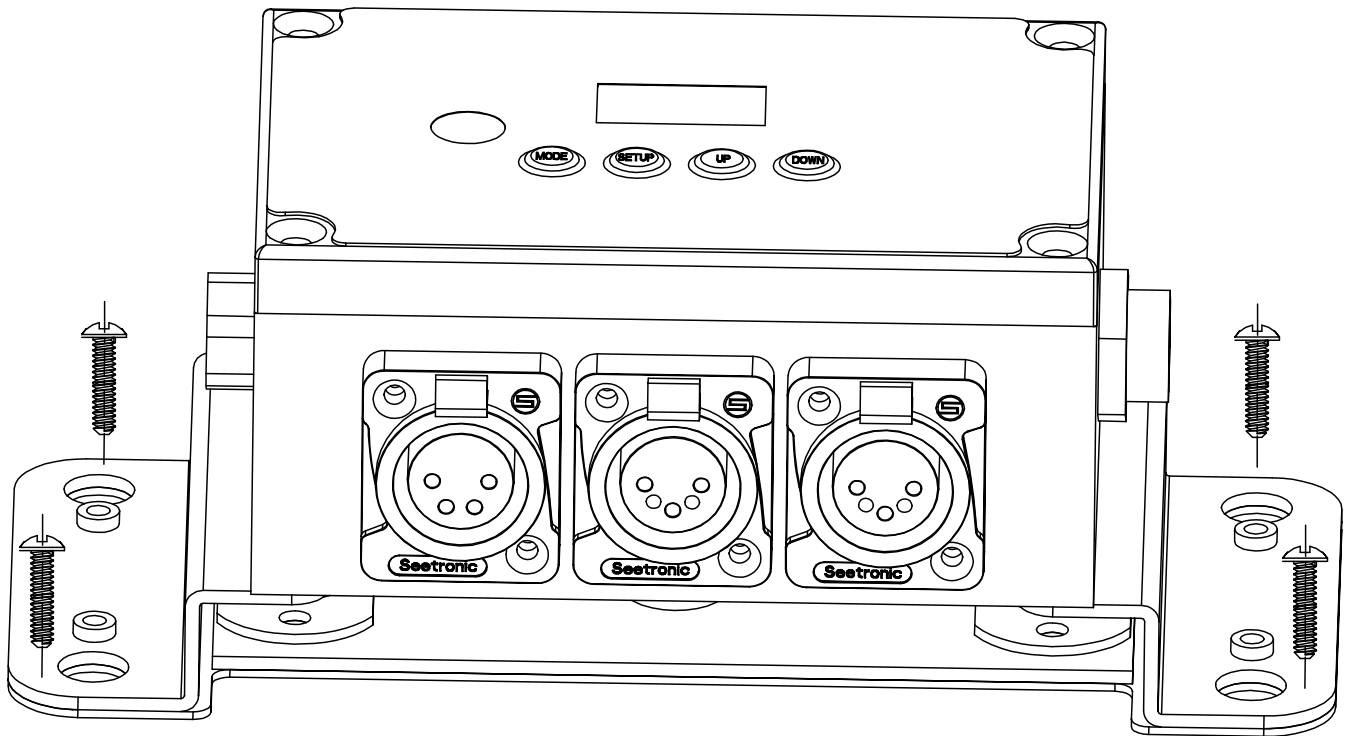

INSTALLATION INSTRUCTIONS

CLAMP MOUNTING

This device features an integrated mounting plate on the back side, which includes two holes for the installation of an Omega bracket. Insert the Omega bracket's twist lock fasteners into the designated holes in the mounting plate, then twist the fasteners to secure the Omega bracket in place. Refer to the images below.

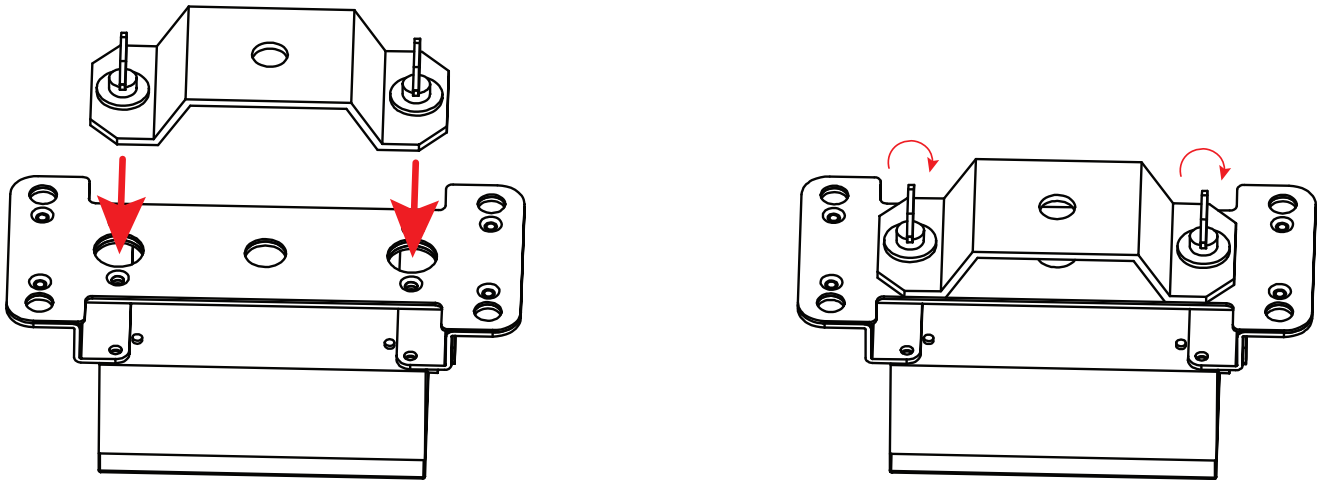

The mounting clamp can then be attached to the Omega bracket. When mounting the fixture to a truss or any other suspended or overhead installation, be sure to secure appropriately rated clamps (not included) to the Omega bracket and attach a separate SAFETY CABLE of the appropriate safety rating to at least one of the holes in the wall mount brackets.

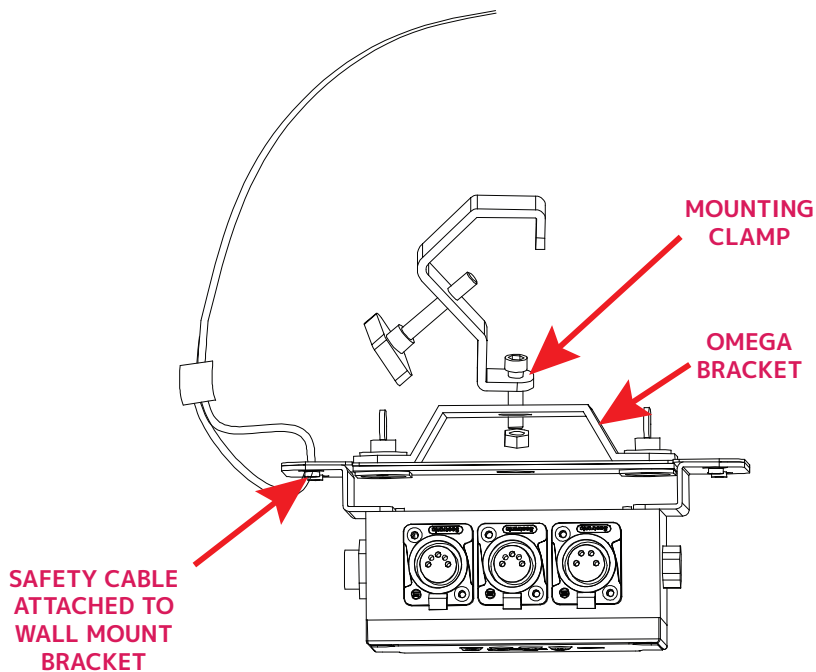

SAFETY CABLE

ALWAYS ATTACH A SAFETY CABLE WHENEVER INSTALLING THIS FIXTURE IN A SUSPENDED ENVIRONMENT TO ENSURE THAT THE FIXTURE WILL NOT FALL IF THE CLAMP FAILS.

REMOTE CONTROL OPERATION

The Elation UC-IR24 infrared remote gives the user control of various functions for a variety of Elation fixtures with IR capabilities. Please note that the remote should be aimed at the front of the fixture, and that maximum operating range is 30 feet.

CONTROLS

- **ON and OFF buttons:** When the ON button is pressed, the lighting fixture switches on and returns to its last running state. When the OFF button is pressed, the unit powers off.
- **STROBE:** The unit shall strobe according to the selected color or program. The strobe rate can be adjusted by repeatedly pressing the + / - buttons, or 15 preset strobe speeds can directly be accessed by pressing buttons 1-15, where 1 is the slowest and 15 is the fastest.
- **SOUND:** The unit shall trigger the last selected program steps based on the primary units microphone. The microphone sensitivity can then be adjusted with the +/- buttons.
- **COLOR:** Select preset static colors using buttons 0-15. The intensity for the set color can then be adjusted with the +/- buttons.
- **PROGRAM:** Internal programs can be selected by pressing buttons 0-13 (Note: since this unit only supports 13 programs, the 14 button and 15 button have no defined function for this unit). The selected program run speed can be adjusted with the +/- buttons.
- **+ and - buttons:** These buttons are used to adjust strobe rate when the STROBE button is active, mic sensitivity when the SOUND button is active, brightness intensity when the COLOR button is active, or program run speed when the PROGRAM button is active. The +/- buttons can be repeatedly pressed adjust the setting by single increments, or pressed and held to quickly make large adjustments.
- **0-15 buttons:** These buttons are used to select preset strobe speeds when the STROBE button is active, static colors when the COLOR button is active, or internal programs when the PROGRAM button is active. Colors stored in buttons 0-15 can be edited from the units menu if desired by the user.

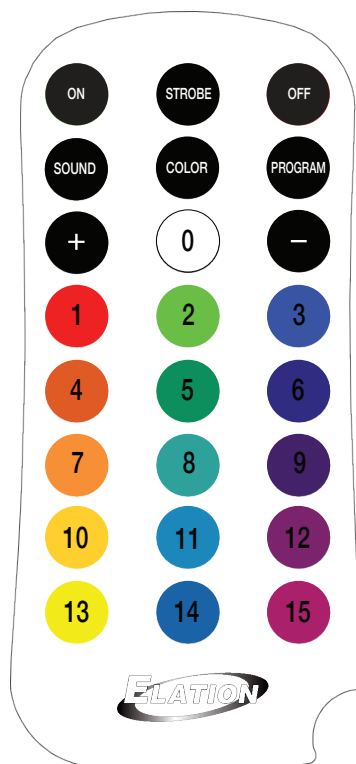

CONTROL PANEL

The Pixel Driver 170IP features a display screen with a 4-button control pad, which can be used to easily adjust any device settings.

Pressing the MODE button will cycle through the various Main Menu options. When the desired Main Menu option is displayed on the screen, press the SETUP button to enter the sub-menu, then use the UP and DOWN buttons to scroll through sub-menu options. In some cases, there will be a second sub-menu that can be navigated in the same way.

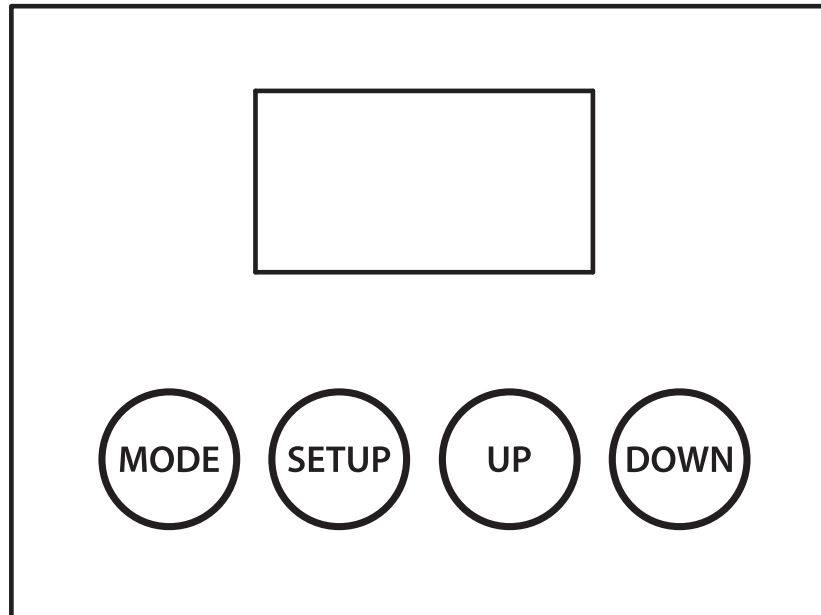

SYSTEM MENU

DMX CONTROL SETTINGS	Address	001 - 512		
	Pixel Count	001 - 170	LED Tape	Total number of pixels that the driver shall control
		001 - 040	Pixel Wash 40IP	
	Pixel Groups (LED Tape Mode only)	Default = 1x170 ; see Pixel Groups section for full list of options		Sets the number and size of pixel groups
	Channel Count	000- 510	LED Tape	Displays the number of DMX channels currently being used; varies depending on Pixel Count
		000 - 160	Pixel Wash 40IP	
	No DMX Status	Blackout		
Internal Programs				
Hold Last				
PERSONALITY	IR Remote	On / Off		
	Display	Screen Saver Delay	1 - 10 , Off	
		Rotate Display 180	Yes / No	
	Hi Power Mode (Pixel Wash 40IP Mode only)	On / Off		8 units max w/ Hi Power off; 5 units max w/ Hi Power on
Service	Passcode = 011	Factory Restore	Yes / No	
MANUAL CONTROL	Red	000 - 255		
	Green	000 - 255		
	Blue	000 - 255		
	White (Pixel Wash 40IP Mode only)	000 - 255		
	Clr Macro	00 - 32		See Color Macros section for details
	Master Dimmer	000 - 255		
INTPROGS	Program 0	Speed	001 - 016	
		Fade	000 - 015	
	Program 1	Speed	001 - 016	
		Fade	000 - 015	
	
	Program 13	Speed	001 - 016	
Fade		000 - 015		
INFORMATION	Software Version	x.xx		
	RDM UID	xxxxxx		
OUTPUT CONTROL	Output Set	Pixel Wash 40IP		
		LED Tape		

DMX TRAITS

CHANNEL		PIXEL NO.	DMX VALUE	FUNCTION
LED Tape	Pixel Wash 40IP			
1	1	1	000 - 255	Red , 0% - 100%
2	2		000 - 255	Green , 0% - 100%
3	3		000 - 255	Blue , 0% - 100%
	4		000 - 255	White , 0% - 100%
4	5	2	000 - 255	Red , 0% - 100%
5	6		000 - 255	Green , 0% - 100%
6	7		000 - 255	Blue , 0% - 100%
	8		000 - 255	White , 0% - 100%
7	9	3	000 - 255	Red , 0% - 100%
8	10		000 - 255	Green , 0% - 100%
9	11		000 - 255	Blue , 0% - 100%
	12		000 - 255	White , 0% - 100%
...
118	157	40	000 - 255	Red , 0% - 100%
119	158		000 - 255	Green , 0% - 100%
120	159		000 - 255	Blue , 0% - 100%
	160		000 - 255	White , 0% - 100%
121		41	000 - 255	Red , 0% - 100%
122			000 - 255	Green , 0% - 100%
123			000 - 255	Blue , 0% - 100%
...	
508		170	000 - 255	Red , 0% - 100%
509			000 - 255	Green , 0% - 100%
510			000 - 255	Blue , 0% - 100%

Note:

- In LED Tape mode, the DMX channel control will vary depending on the set pixel count. 3 RGB control channels will be added for each additional pixel. Up to 170 pixels (510 DMX channels) can be controlled with each Pixel Driver 170IP device.
- In Pixel Wash 40IP mode, the DMX channel control will vary depending on the set pixel count. 4 RGBW control channels will be added for each additional pixel. Up to 40 pixels (160 DMX channels) can be controlled with each Pixel Driver 170IP device.

PIXEL GROUPS

The number of pixels that this device can control is limited by the available number of DMX control channels. The device has a total of 512 available DMX control channels, and each pixel requires three channels (red, green, and blue) to operate. Therefore, the maximum number of pixels that can be controlled in standard configuration is 170: 170 pixels x 3 channels per pixel = 510 channels. This is the maximum number of 3-channel groups that can be accommodated without exceeding the 512 channel limitation.

However, this device also gives the user the ability to adjust the pixel grouping configuration. In the standard configuration, individual pixels are controlled independently for finer control over the resolution of the lighting display. Alternately, multiple individual pixels may be grouped together under a common set of control channels in order to reduce the number of required control channels. This also reduces the effective pixel count for each fixture. The downside to this is the reduced resolution of the lighting display.

In each pixel control mode, the first number denotes the number of individual pixels that make up each control group, while the second number denotes the number of control groups. Each control group will always occupy 3 DMX channels (for red, green, and blue control). This means that within each control group, all pixels will be controlled by the same set of 3 DMX channels.

For example, let us examine a 30-pixel strip, as shown below. Selecting **2x15** mode means that the pixels will be divided into 15 control groups, with each group containing 2 LEDs.

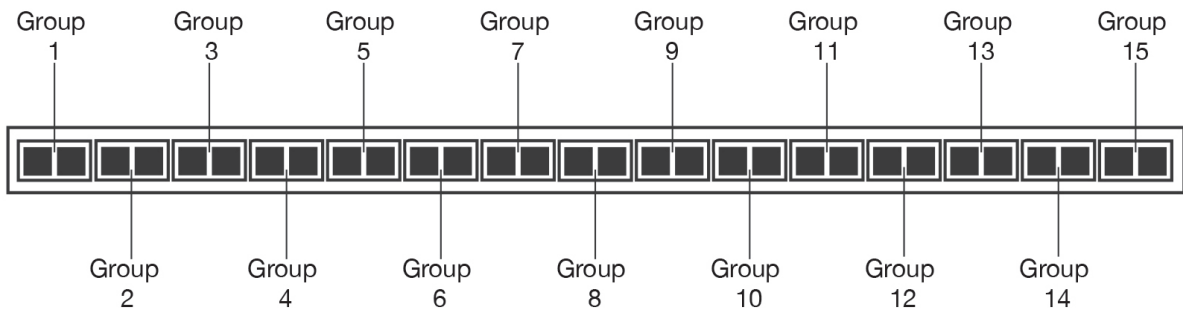

In this mode, a total of 45 DMX channels are used: 3 DMX channels (for Red, Green, Blue) per group multiplied by 15 groups.

If we want to reduce the number of control groups required, one possible solution is to select a different pixel grouping mode. For instance, selecting **3x10** mode will result in the LED display being divided into 10 control groups each containing 3 pixels. Therefore, the number of DMX channels required drops to 30: 10 control groups multiplied by 3 DMX channels (for Red, Green, and Blue) per group.

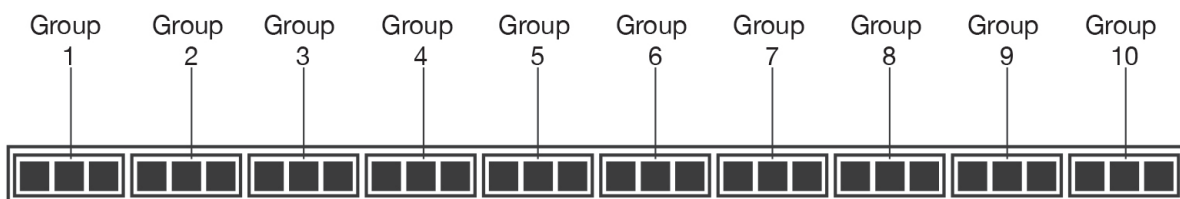

Available pixel grouping modes are shown in the tables on the following pages.

PIXEL GROUPS

PIXEL COUNT	PIXEL GROUP OPTIONS
1	1x1
2	1x2, 2x1
3	1x3, 3x1
4	1x4, 2x2, 4x1
5	1x5, 5x1
6	1x6, 2x3, 3x2, 6x1
7	1x7
8	1x8, 2x4, 4x2, 8x1
9	1x9, 3x3, 9x1
10	1x10, 2x5, 5x2, 10x1
11	1x11
12	1x12, 2x6, 3x4, 4x3, 6x2, 12x1
13	1x13
14	1x14, 2x7, 7x2, 14x1
15	1x15, 3x5, 5x3, 15x1
16	1x16, 2x8, 4x4, 8x2, 16x1
17	1x17
18	1x18, 2x9, 3x6, 6x3, 9x2, 18x1
19	1x19
20	1x20, 2x10, 4x5, 5x4, 10x2, 20x1
21	1x21, 3x7, 7x3, 21x1
22	1x22, 2x11, 11x2, 22x1
23	1x23
24	1x24, 2x12, 3x8, 4x6, 6x4, 8x3, 12x2, 24x1
25	1x25, 5x5, 25x1
26	1x26, 2x13, 13x2, 26x1
27	1x27, 3x9, 9x3, 27x1
28	1x28, 2x14, 4x7, 7x4, 14x2, 28x1
29	1x29
30	1x30, 2x15, 3x10, 5x6, 6x5, 10x3, 15x2, 30x1
31	1x31
32	1x32, 2x16, 4x8, 8x4, 16x2, 32x1
33	1x33, 3x11, 11x3, 33x1
34	1x34, 2x17, 17x2, 34x1
35	1x35, 5x7, 7x5, 35x1
36	1x36, 2x18, 3x12, 4x9, 6x6, 9x4, 12x3, 18x2, 36x1
37	1x37
38	1x38, 2x19, 19x2, 38x1

PIXEL COUNT	PIXEL GROUP OPTIONS
39	1x39, 3x13, 13x3, 39x1
40	1x40, 2x20, 4x10, 5x8, 8x5, 10x4, 20x2, 40x1
41	1x41
42	1x42, 2x21, 3x14, 6x7, 7x6, 14x3, 21x2, 42x1
43	1x43
44	1x44, 2x22, 4x11, 11x4, 22x2, 44x1
45	1x45, 3x15, 5x9, 9x5, 15x3, 45x1
46	1x46, 2x23, 23x2, 46x1
47	1x47
48	1x48, 2x24, 3x16, 4x12, 6x8, 8x6, 12x4, 16x3, 24x2, 48x1
49	1x49, 7x7, 49x1
50	1x50, 2x25, 5x10, 10x5, 25x2, 50x1
51	1x51, 3x17, 17x3, 51x1
52	1x52, 2x26, 4x13, 13x4, 26x2, 52x1
53	1x53
54	1x54, 2x27, 3x18, 6x9, 9x6, 18x3, 27x2, 54x1
55	1x55, 5x11, 11x5, 55x1
56	1x56, 2x28, 4x14, 7x8, 8x7, 14x4, 28x2, 56x1
57	1x57, 3x19, 19x3, 57x1
58	1x58, 2x29, 29x2, 58x1
59	1x59
60	1x60, 2x30, 3x20, 4x15, 5x12, 6x10, 10x6, 12x5, 15x4, 20x3, 30x2, 60x1
61	1x61
62	1x62, 2x31, 31x2, 62x1
63	1x63, 3x21, 7x9, 9x7, 21x3, 63x1
64	1x64, 2x32, 4x16, 8x8, 16x4, 32x2, 64x1
65	1x65, 5x13, 13x5, 65x1
66	1x66, 2x33, 3x22, 6x11, 11x6, 22x3, 33x2, 66x1
67	1x67
68	1x68, 2x34, 4x17, 17x4, 34x2, 68x1
69	1x69, 3x23, 23x2, 69x1
70	1x70, 2x35, 5x14, 7x10, 10x7, 14x5, 35x2, 70x1
71	1x71

PIXEL GROUPS

PIXEL COUNT	PIXEL GROUP OPTIONS
72	1x72, 2x36, 3x24, 4x18, 6x12, 8x9, 9x8, 12x6, 18x4, 24x3, 36x2, 72x1
73	1x73
74	1x74, 2x37, 37x2, 74x1
75	1x75, 3x25, 5x15, 15x5, 25x3, 75x1
76	1x76, 2x38, 4x19, 19x3, 38x2, 76x1
77	1x77, 7x11, 11x7, 77x1
78	1x78, 2x39, 3x26, 6x13, 13x6, 26x3, 39x2, 78x1
79	1x79
80	1x80, 2x40, 4x20, 5x16, 8x10, 10x8, 16x5, 20x4, 40x2, 80x1
81	1x81, 3x27, 9x9, 27x3, 81x1
82	1x82, 2x41, 41x2, 82x1
83	1x83
84	1x84, 2x42, 3x28, 4x21, 6x14, 7x12, 12x7, 14x6, 21x4, 28x3, 42x2, 84x1
85	1x85, 5x17, 17x5, 85x1
86	1x86, 2x43, 43x2, 86x1
87	1x87, 3x29, 29x3, 87x1
88	1x88, 2x44, 4x22, 8x11, 11x8, 22x4, 44x2, 88x1
89	1x89
90	1x90, 2x45, 3x30, 5x18, 6x15, 9x10, 10x9, 15x6, 18x5, 30x3, 45x2, 90x1
91	1x91, 7x13, 13x7, 91x1
92	1x92, 2x46, 4x23, 23x4, 46x2, 92x1
93	1x93, 3x31, 31x2, 93x1
94	1x94, 2x47, 47x2, 94x1
95	1x95, 5x19, 19x5, 95x1
96	1x96, 2x48, 3x32, 4x24, 6x16, 8x12, 12x8, 16x6, 24x4, 32x4, 48x2, 96x1
97	1x97
98	1x98, 2x49, 7x14, 14x7, 49x2, 98x1
99	1x99, 3x33, 9x11, 11x9, 33x3, 99x1
100	1x100, 2x50, 4x25, 5x20, 10x10, 20x5, 25x4, 50x2, 100x1
101	1x101
102	1x102, 2x51, 3x34, 6x17, 17x6, 34x3, 51x2, 102x1
103	1x103

PIXEL COUNT	PIXEL GROUP OPTIONS
104	1x104, 2x52, 4x26, 8x13, 13x8, 26x4, 52x2, 104x1
105	1x105, 3x35, 5x21, 7x15, 15x7, 21x5, 35x3, 105x1
106	1x106, 2x53, 53x2, 106x1
107	1x107
108	1x108, 2x54, 3x36, 4x27, 6x18, 9x12, 12x9, 18x6, 27x4, 36x3, 54x2, 108x1
109	1x109
110	1x110, 2x55, 5x22, 10x11, 11x10, 22x5, 55x2, 110x1
111	1x111, 3x37, 37x3, 111x1
112	1x112, 2x56, 4x28, 7x16, 8x14, 14x8, 16x7, 28x4, 56x2, 112x1
113	1x113
114	1x114, 2x57, 3x38, 6x19, 19x6, 38x3, 57x2, 114x1
115	1x115, 5x23, 23x5, 115x1
116	1x116, 2x58, 4x29, 29x4, 58x2, 116x1
117	1x117, 3x39, 9x13, 13x9, 39x3, 117x1
118	1x118, 2x59, 59x2, 118x1
119	1x119, 7x17, 17x7, 119x1
120	1x120, 2x60, 3x40, 4x30, 5x24, 6x20, 8x15, 10x12, 12x10, 15x8, 20x6, 24x5, 30x4, 40x3, 60x2, 120x1
121	1x121, 11x11, 121x1
122	1x122, 2x61, 61x2, 122x1
123	1x123, 3x41, 41x3, 123x1
124	1x124, 2x62, 4x31, 31x4, 62x2, 124x1
125	1x125, 5x25, 25x5, 125x1
126	1x126, 2x63, 3x42, 6x21, 7x18, 9x14, 14x9, 18x7, 21x6, 42x3, 63x2, 126x1
127	1x127
128	1x128, 2x64, 4x32, 8x16, 16x8, 32x4, 64x2, 128x1
129	1x129, 3x43, 43x3, 129x1

PIXEL GROUPS

PIXEL COUNT	PIXEL GROUP OPTIONS
130	1x130, 2x65, 5x26, 10x10, 13x10, 26x5, 65x2, 130x1
131	1x131
132	1x132, 2x66, 3x44, 4x33, 6x22, 11x12, 12x11, 22x6, 33x4, 44x3, 66x2, 132x1
133	1x133, 7x19, 19x7, 133x1
134	1x134, 2x67, 67x2, 134x1
135	1x135, 3x45, 5x27, 9x15, 15x9, 27x5, 45x3, 135x1
136	1x136, 2x68, 4x34, 8x17, 17x8, 34x4, 68x2, 136x1
137	1x137
138	1x138, 2x69, 3x46, 6x23, 23x6, 46x3, 69x2, 138x1
139	1x139
140	1x140, 2x70, 4x35, 5x28, 7x20, 10x14, 14x10, 20x7, 28x5, 35x4, 70x2, 140x1
141	1x141, 3x47, 47x3, 141x1
142	1x142, 2x71, 71x2, 142x1
143	1x143, 11x13, 13x11, 143x1
144	1x144, 2x72, 3x48, 6x36, 8x24, 9x18, 12x16, 16x12, 18x9, 24x8, 36x6, 48x3, 72x2, 144x1
145	1x145, 5x29, 29x5, 145x1
146	1x146, 2x73, 73x2, 146x1
147	1x147, 3x49, 7x21, 21x7, 49x3, 147x1
148	1x148, 2x74, 4x37, 37x4, 74x2, 148x1
149	1x149
150	1x150, 2x75, 3x50, 5x30, 6x25, 10x15, 15x10, 25x6, 30x5, 50x3, 75x2, 150x1
151	1x151
152	1x152, 2x76, 4x38, 8x19, 19x8, 38x4, 76x2, 152x1
153	1x153, 3x51, 9x17, 17x9, 51x3, 153x1
154	1x154, 2x77, 7x22, 11x14, 14x11, 22x7, 77x2, 154x1
155	1x155, 5x31, 31x5, 155x1

PIXEL COUNT	PIXEL GROUP OPTIONS
156	1x156, 2x78, 3x52, 4x39, 6x26, 12x13, 13x12, 26x6, 39x4, 52x3, 78x2, 156x1
157	1x157
158	1x158, 2x79, 79x2, 158x1
159	1x159, 3x53, 53x3, 159x1
160	1x160, 2x80, 4x40, 5x32, 8x20, 10x16, 16x10, 20x8, 32x5, 40x4, 80x2, 160x1
161	1x161, 7x23, 23x7, 161x1
162	1x162, 2x81, 3x54, 6x27, 9x18, 18x9, 27x6, 54x3, 81x2, 162x1
163	1x163
164	1x164, 2x82, 4x41, 41x4, 82x2, 164x1
165	1x165, 3x55, 5x33, 11x15, 15x11, 33x5, 55x3, 165x1
166	1x166, 2x83, 83x2, 166x1
167	1x167
168	1x168, 2x84, 3x56, 4x42, 6x28, 7x24, 8x21, 12x14, 14x12, 21x8, 24x7, 28x6, 42x4, 56x3, 84x2, 168x1
169	1x169, 13x13, 169x1
170	1x170, 2x85, 5x34, 10x17, 17x10, 34x5, 85x2, 170x1

COLOR MACROS

NAME	DMX VALUES	RED	GREEN	BLUE
Off	000	0	0	0
Bastard Amber	001 - 007	255	206	143
Medium Amber	008 - 015	254	177	153
Pale Amber Gold	016 - 023	254	192	138
Gallo Gold	024 - 031	254	165	98
Golden Amber	032 - 039	254	121	0
Light Red	040 - 047	176	17	0
Medium Red	048 - 055	96	0	11
Medium Pink	056 - 063	234	139	171
Broadway Pink	064 - 071	224	5	97
Follies Pink	072 - 079	175	77	173
Light Lavender	080 - 087	119	130	199
Special Lavender	088 - 095	147	164	212
Lavender	096 - 103	88	2	163
Indigo	104 - 111	0	38	86
Hemsley Blue	112 - 119	0	142	208
Tipton Blue	120 - 127	52	148	209
Light Steel Blue	128 - 135	1	134	201
Light Sky Blue	136 - 143	0	145	212
Sky Blue	144 - 151	0	121	192
Brilliant Blue	152 - 159	0	129	184
Light Green Blue	160 - 167	0	83	115
Bright Blue	168 - 175	0	97	166
Primary Blue	176 - 183	1	100	167
Congo Blue	184 - 191	0	40	86
Pale Yellow Green	192 - 199	209	219	182
Moss Green	200 - 207	42	165	85
Primary Green	208 - 215	0	46	35
Double CTB	216 - 223	8	107	222
Full Red	224 - 231	255	0	0
Full Green	232 - 239	0	255	0
Full Blue	240 - 247	0	0	255
White	248 - 255	255	255	255

MAINTENANCE GUIDELINES



DISCONNECT POWER BEFORE PERFORMING ANY MAINTENANCE!

MAINTENANCE

Regular inspections are recommended to ensure proper function and extended life. There are no user serviceable parts inside this device. Please refer all other service issues to an authorized Elation service technician. Should you need any spare parts, please order genuine parts from your local Elation dealer.

Please refer to the following points during routine inspections:

- A. A detailed electrical check by an approved electrical engineer every three months, to make sure the circuit contacts are in good condition and prevent overheating.
- B. Be sure all screws and fasteners are securely tightened at all times. Loose screws may fall out during normal operation, resulting in damage or injury as larger parts could fall.
- C. Check for any deformations on the housing, rigging hardware, and rigging points (ceiling, suspension, trussing). Deformations in the housing could allow for dust to enter into the fixture. Damaged rigging points or unsecured rigging could cause the device to fall and seriously injure a person(s).
- D. Electric power supply cables must not show any damage, material fatigue, or sediments.

NEVER remove the ground prong from the power cable.

TORQUE SETTINGS FOR SCREWS

Following any repair or maintenance procedure in which the device's cover has been removed or opened, the cover screws must be tightened with a torque driver in order to maintain the stated IP rating. **All cover screws should be torqued to 11.3 lb-in (13.0 kg-cm).**

TORQUE DRIVERS (Recommended): UTICA TS-30 (Shown)

TORQUE DRIVER (Alternate):

- Proto J6107A
- Wiha 28887



CAUTION! DO NOT OVER TORQUE SCREWS AS THIS CAN CAUSE LEAKAGE ISSUES!

SPECIFICATIONS

CONTROL / CONNECTIONS

4-Button OLED Display

1 DMX Universe (170 Pixels)

LED Control: LED Tape or Pixel Wash 40IP

UC-IR24EL Remote (Included)

DMX Input via 5pin XLR Connector

DMX Output via 5pin XLR Connector

LED Out via 4pin XLR Connector

Hi Power Mode Off:

- control up to 8pcs Pixel Wash 40IP with the driver alone
- control up to 40pcs Pixel Wash 40IP with the use of 4pcs Pixel Amp 200

Hi Power Mode On:

- control up to 5pcs Pixel Wash 40IP with the driver alone
- control up to 25pcs Pixel Wash 40IP with the use of 4pcs Pixel Amp 200

SIZE / WEIGHT

Length: 3.68" (93.5mm)

Width: 7.38" (187.5mm)

Height (No Omega Bracket: 3" (75.7mm)

Height (With Omega Bracket: 4.4" (111.0mm)

Weight: 2.64 lbs. (1.2kgs.)

ELECTRICAL

DC Input 12-24VDC, 8.4A (Requires separate power supply)

200W Max Power Consumption

INCLUDED ACCESSORIES:

EL-IR Remote

IR Receiver Cable

2-pin Power Cable to adapt to PSU

APPROVALS / RATING

CE | RoHs | cETL | FCC IP65



*Specifications are subject to change without notice.

DIMENSIONAL DRAWINGS

Dimension drawings not to scale

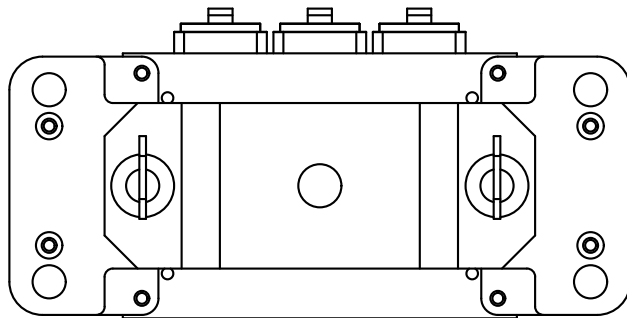
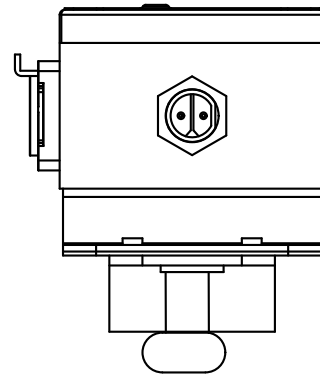
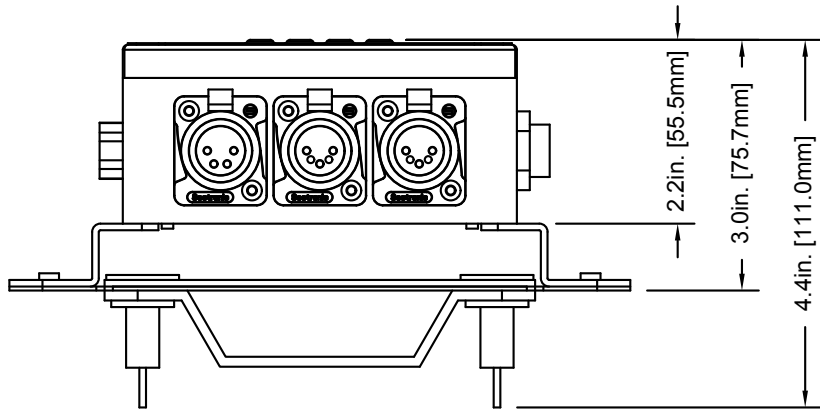
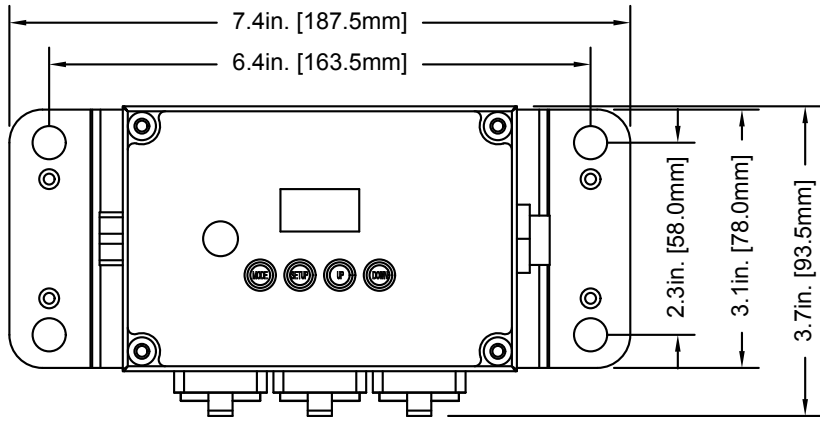

OPTIONAL ACCESSORIES

SKU	ITEM
PIX618	Pixel Tape 16IP
PIX600	Pixel Wash 40IP
PIX685	Pixel Amp 200

SOFTWARE UPDATES

NOTICE: Before beginning the software update procedure, please contact Elation service for information, directions, and guidance. **DO NOT** proceed without contacting Elation service first!

1. Copy the software update file to a Micro SD card.
2. Insert the Micro SD card into the Uploader.
3. Power on the Uploader and wait until the LCD displays "HUAYAO Software Update Box". Use UP and DOWN buttons to scroll to "Output Type", then press ENTER to confirm. Use UP and DOWN buttons to select "DMX", then press ENTER button again to confirm.
4. Use UP and DOWN buttons to select "Devices Upgrade", then press ENTER button to confirm. Use UP and DOWN button to select the software update file which you want to upload to the Pixel Driver 170IP. Press the ENTER button again. The upload interface should now be displayed.
5. Power on the Pixel Driver 170IP and set it to DMX mode. Use a 5 pin DMX cable to connect the Pixel Driver 170IP to the Uploader.
6. Press the ENTER button. The Uploader will begin to upload the new software to the Pixel Driver 170IP. After the upload has been completed, press EXIT button to exit the uploader interface.
7. Power off and then restart Pixel Driver 170IP.
8. Check if Pixel Driver 170IP has been updated to the new software by checking the software version listed in the system menu. If the update was not successful, please repeat the process.

FCC STATEMENT

Please note that changes or modifications of this product is not expressly approved by the party responsible for compliance could void the user's authority to operate the equipment.

NOTE: This equipment has been tested and found to comply with the limits for a Class A digital device, pursuant to part 15 of the FCC Rules. These limits are designed to provide reasonable protection against harmful interference when the equipment is operated in a commercial environment. This equipment generates, uses, and can radiate radio frequency energy and, if not installed and used in accordance with the instruction manual, may cause harmful interference to radio communications. Operation of this equipment in a residential area is likely to cause harmful interference in which case the user will be required to correct the interference at his own expense.



