

SMARTY MAX



DATA SHEET



KEY FEATURES

- Extreme Output 3-in-1 Beam, Spot, Wash Hybrid Fixture
- Flex Lamp Technology from 370 to 480W plus Smart Hibernation with up to 4,000 Hour Lamp Life
- Full CMY Color Mixing System, Variable CTO, Color Wheel
- Creative FX Package: 8 Rotating and 14 Static Gobos, Dual Track Animation, Iris 4x Prism on Dual Planes, 2x Frost
- Ultra-Fast Zoom: Beam 2° - 20° | Spot 3° - 30° | Wash 9° - 35°
- 2 Years / 4,000 Hours Ultimate Warranty**
- **First 2 Years of operation or 4,000 hours of use, whichever comes first, based on regular fixture/lamp maintenance.

The **SMARTY MAX™** combines high output and long lamp life in a feature packed compact and lightweight Hybrid fixture. **SMARTY MAX** is the Extreme Output Hybrid featuring the new Philips MSD Platinum FLEX 400 lamp, and Elation's 2 year / 4,000 hours Ultimate Warranty.** Rated at 480W and up to 4,000 hours smart lamp life the **SMARTY MAX** includes CMY and variable CTO and is the world's first Hybrid incorporating a full Iris for dynamic beam effects. Four prisms on two planes, dual frosts plus dual gobo wheel and the unique dual track animation round out the comprehensive FX package in a compact and lightweight housing. Delivering 21,000 lumens from its large 160mm front aperture, the **SMARTY MAX** has a crisp output for extremely powerful beams, sharp gobos and bright washes, making it a flexible fixture for almost any application, while providing an excellent return on investment.



Specifications are subject to change without notice ©Elation Professional 08/31/2023

Elation Professional USA | 6122 S. Eastern Ave. | Los Angeles, CA. 90040
323-582-3322 | 323-832-9142 fax | www.elationlighting.com | info@elationlighting.com

Elation Professional B.V. | Junostraat 2 | 6468 EW Kerkrade, The Netherlands
+31 45 546 85 66 | +31 45 546 85 96 fax | www.elationlighting.eu | info@elationlighting.eu

SMARTY MAX



SPECIFICATIONS

SOURCE

Philips MSD Platinum 400 Flex 480W Lamp
Variable Lamp Power 370/470/480W
Automated Lamp Hibernation with Instant Recovery

Up to 4,000 Hour Lamp Life*

*Test lab conditions. May vary depending on several factors including but not limited to: Environmental Conditions, Power/Voltage, Usage Patterns (On-Off Cycling), Control, and Dimming.

PHOTOMETRIC DATA

21,000+ Lumen Total Fixture Output
1.5° Beam: 1,784,448 LUX (165,781 FC) @5m (16.4ft)
3° Spot: 462,508 LUX (42,968 FC) @5m (16.4ft)
Beam
Zoom Range 2° - 20°
Beam Angle 0.8° - 6.5°
Field Angle 1.8° - 16.2°
Spot
Zoom Range 3° - 30°
Beam Angle 1.7° - 14.8°
Field Angle 3° - 26.5°
Wash
Zoom Range 9° - 35°
Beam Angle 6.8° - 29°
Field Angle 12.8° - 39.4°

EFFECTS

Beam, Spot and Wash Modes
Motorized Zoom
Dual Frost Filter for Light Frost/ Full Wash
4 Prisms on Dual Planes
Iris
CMY Color, Gobo, Prism Macros
Motorized Focus with Auto-Focus Feature
High Speed Shutter and Strobe
Pan Angle: 540°/630°
Tilt Angle: 248°

COLOR

Full CMY Color Mixing System
Variable CTO
13 Position Color Wheel

GOBOS

2 Gobo Wheels
8 Interchangeable-Rotating / Indexing Glass Gobos
14 Static-Stamped Metal Gobos
Dual Track Animation Wheel

CONTROL / CONNECTIONS

2 DMX Channel Modes (27 / 44 Channels)
(6) Button Touch Panel
Full Color 180° Reversible LCD Menu Display
DMX, RDM, Art-Net and sACN Protocol Support
5pin DMX In/Out
RJ45 Ethernet In/Out
IP65 Locking Power Cable In/Out
With Wired Digital Communication Network

SIZE / WEIGHT

Length: 15.34" (389.8mm)
Width: 17.53" (445.3mm)
Height: 25.27" (642mm)
Center Spacing: 21.0" (533mm)
Weight: 60.0 lbs. (27.2kg)

ELECTRICAL / THERMAL

AC 100-240V 50/60Hz
700 W Max Power Consumption (estimated)
14°F to 113°F (-10°C to 45°C)
BTU/hr (+/- 10%) 2387

APPROVALS / RATINGS

CE | cETLus | IP20



Specifications are subject to change without notice ©Elation Professional 08/31/2023

Elation Professional USA | 6122 S. Eastern Ave. | Los Angeles, CA. 90040
323-582-3322 | 323-832-9142 fax | www.elationlighting.com | info@elationlighting.com

Elation Professional B.V. | Junostraat 2 | 6468 EW Kerkrade, The Netherlands
+31 45 546 85 66 | +31 45 546 85 96 fax | www.elationlighting.eu | info@elationlighting.eu

SMARTY MAX



GOBOS | ANIMATION WHEEL

INTERCHANGEABLE-ROTATING GLASS GOBO WHEEL1

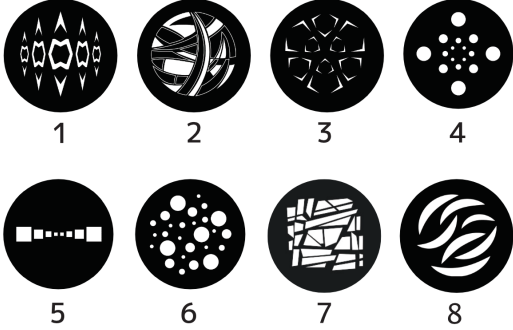

INTERCHANGEABLE-ROTATING GLASS GOBO WHEEL1

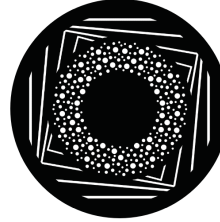

STATIC-FIXED METAL GOBO WHEEL2

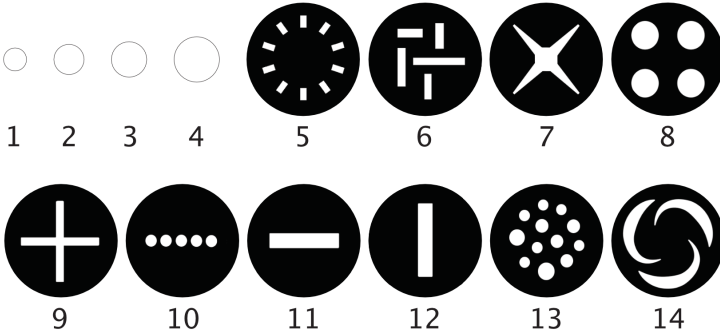

ORDERING INFORMATION

SKU (US)	SKU (EU)	DESCRIPTION
ESM166	1237000115	Elation Smarty Max
TRIGGER CLAMP	1741000032	Heavy Duty Wrap Around Hook Style Clamp
AC5PDMX5PRO	N/A	5 ft (1.5m) 5pin Pro DMX Cable
NEU088	N/A	3 ft (1m) Power Link Cable
ZB0MSD PLATINUM 400L FLEX	N/A	Philips MSD Platinum 400 Flex Lamp



SMARTY MAX



UNIT DIMENSIONS

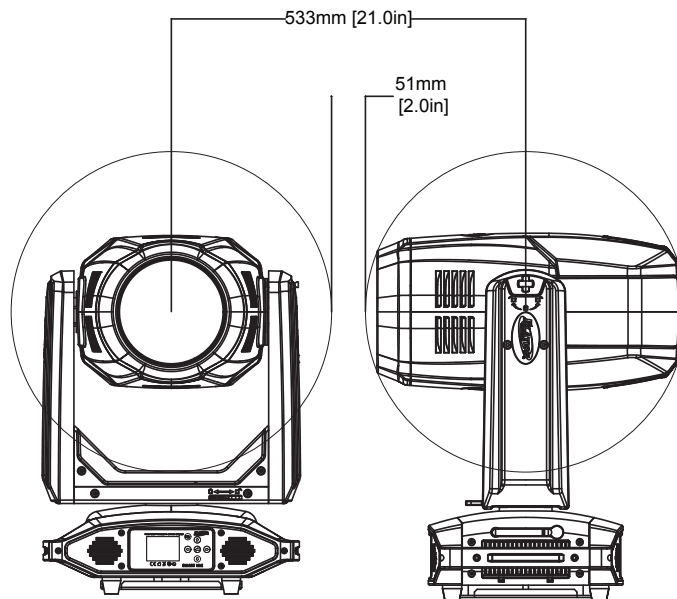
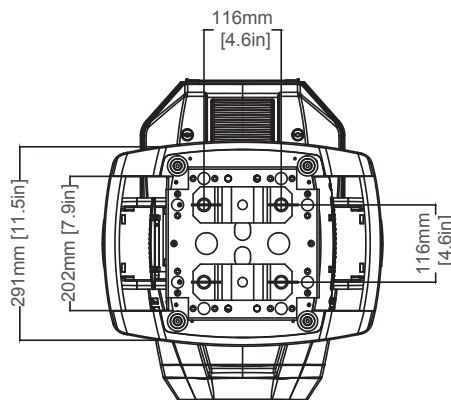
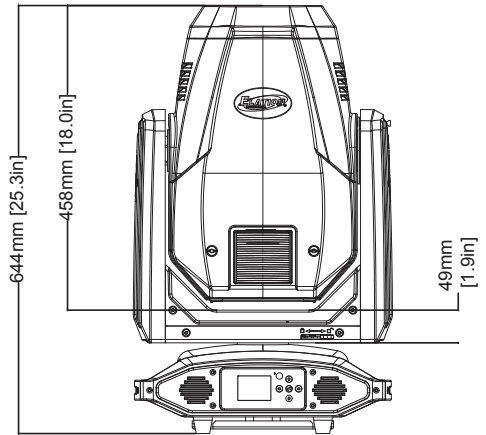
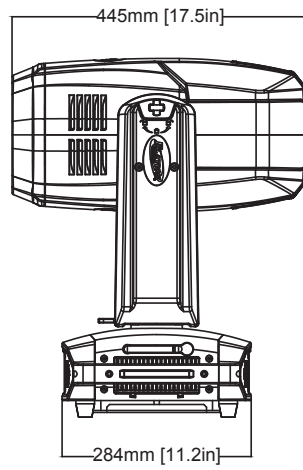
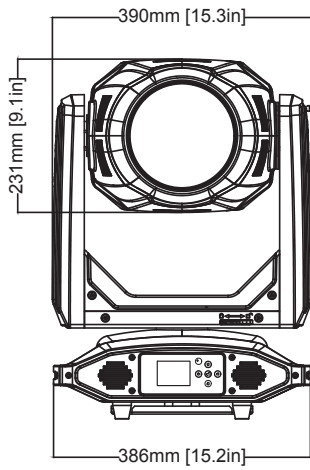

SMARTY MAX



FOAM IN-LAY DIMENSIONS

