



FUZE MAX Spot-Profile

Photometric Test Report

©2022 **ELATION PROFESSIONAL** all rights reserved. Information, specifications, diagrams, images, and instructions herein are subject to change without notice. ELATION PROFESSIONAL logo and identifying product names and numbers herein are trademarks of ELATION PROFESSIONAL. Copyright protection claimed includes all forms and matters of copyrightable materials and information now allowed by statutory or judicial law or hereinafter granted. Product names used in this document may be trademarks or registered trademarks of their respective companies and are hereby acknowledged. All non-ELATION brands and product names are trademarks or registered trademarks of their respective companies.

Elation Professional USA | 6122 S. Eastern Ave. | Los Angeles, CA. 90040

323-582-3322 | 323-832-9142 fax | www.elationlighting.com | info@elationlighting.com

Elation Professional B.V. | Junostraat 2 | 6468 EW Kerkrade, The Netherlands

+31 45 546 85 66 | +31 45 546 85 96 fax | www.elationlighting.eu | info@elationlighting.eu

Elation Professional Mexico | AV Santa Ana 30 | Parque Industrial Lerma, Lerma, Mexico 52000

+52 (728) 282-7070

CONTENTS

Testing Process	4
Zoom 100%	5
Zoom 50%	10
Zoom 0%	15
2700K	20
3200K	25
4500K	30
5600K	35
6000K	40
6500K	45
Red	50
Green	51
Blue	52
Mint	53
Amber	54

Testing Process

Total Lumen Measurements

Lumens are measured using a Viso Systems Lab Spion. As a goniophotometer, the Viso calculates the field lumens of the fixture by taking multiple measurements across the light beam.

Many lumens figures provided for entertainment lighting fixtures are only 2π sphere values, some even emphasize the LED engine lumens. All Elation product photometric data is the actual light output from the fixture lens, never a theoretical value based on calculation or using the source lumens as the fixtures output. We advise to always compare total fixture lumens acquired with identical measurement systems when comparing lighting fixtures.

Test Lab Equipment and Process

Elation operates an optical testing laboratory at its Los Angeles, CA headquarters to provide accurate photometric data for its lighting products. The testing lab is both light and climate- controlled and contains a variety of precise lighting measurement systems. Fixtures are analyzed with the sophisticated [Viso Systems Lab Spion](#) equipment, which measures all light and color parameters by panning the light beam at a precise speed and from different angles through a calibrated, laser aligned light and color sensor. Test data is collected and summarized by the Viso Light Inspector software. This type of measurement system is referred to as a Goniophotometer.

The Viso software calculates all relevant types of measurements, from beam angles, candela to center light intensity at a variety of distances to the latest color quality measurements like TM30 or CQS as well as accurate color temperature. This wealth of data is then processed by an Elation specific template which is included in the photometric test report for various fixture conditions such as zoom angles and color correction filters.

The Viso software also creates IES (Illuminating Engineering Society) files for each test report. IES is an industry standard file format created for the easy electronic transfer of photometric test data, which is widely used by lighting manufacturers for photometric data distribution.

Additionally, fixtures are periodically rechecked for accuracy using various hand-held light meters including one or more of the devices listed below. This is done to ensure the test data contained in this report is as accurate as possible.

[Asenstek Lighting Passport](#) | [Konica Minolta T-10](#) | [Sekonic C700T](#)

Photometric Report

Total Lumen Output*

Integrating Sphere 19508 lm

VISO Lab Spion 19334 lm

Beam Angle 50%	Field Angle 10%	Cutoff Angle 2.5%
50.3°	55°	58.7°

Color Temperature: 6877 K

CRI: 90.6

TLCI: 94

TM30: 88.8

CQS: 90.7

Voltage: 118 V, Current: 8.94 A

Power: 1055 W

Efficacy: 18 Lumen/Watt

Measurement Date: 3/18/2022

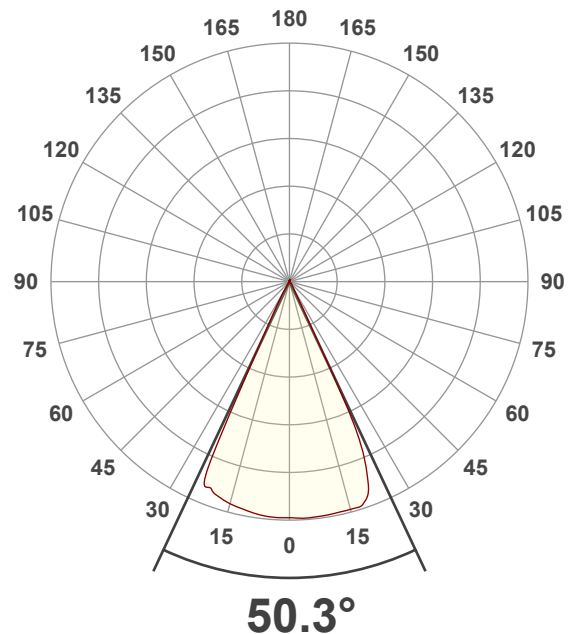

Spectral Distribution

Dominant Wavelength 499 nm

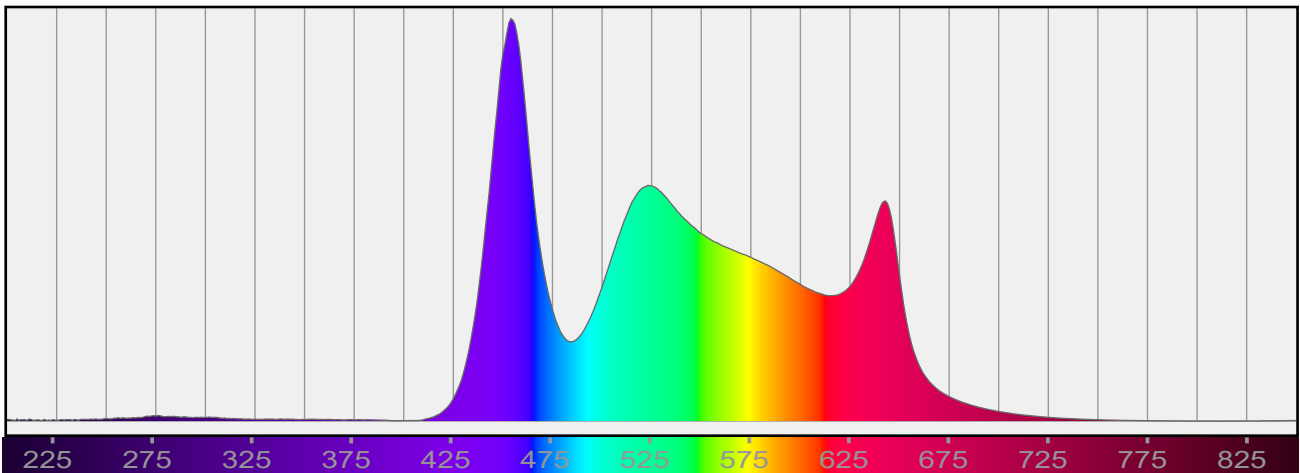

*Total Lumen measurements by calibrated Everfine 2π Integrating Sphere and Viso Systems Lab Spion

Beam Details

Beam Angle 50%	Field Angle 10%	Cutoff Angle 2,5%
50.3°	55°	58.7°

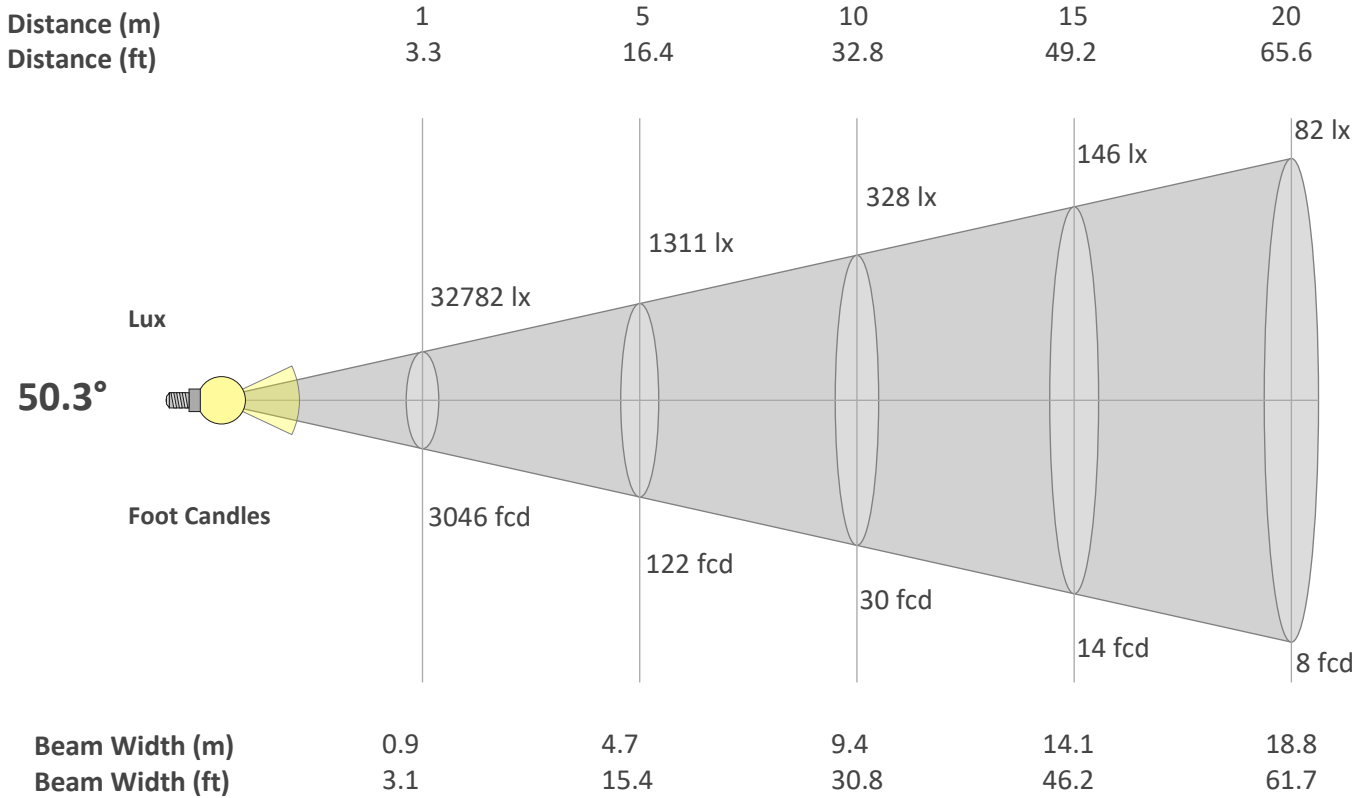

Beam Intensities from 1-20m

M	1	2	3	4	5	6	7	8	9	10	11	12	13	14	15	16	17	18	19	20
FT	3.3	6.6	9.8	13.1	16.4	19.7	23	26.2	29.5	32.8	36.1	39.4	42.7	45.9	49.2	52.5	55.8	59.1	62.3	65.6
LX	32782	8195	3642	2049	1311	911	669	512	405	328	271	228	194	167	146	128	113	101	91	82
FC	3045.5	761.4	338.4	190.3	121.8	84.6	62.2	47.6	37.6	30.5	25.2	21.1	18	15.5	13.5	11.9	10.5	9.4	8.4	7.6

Linear Distribution

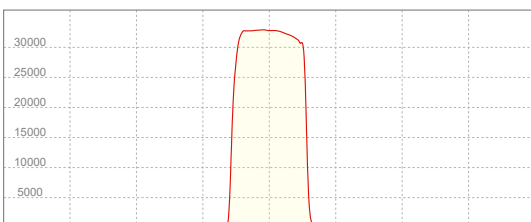

Peak Candela
32912 cd

Calculate Center Beam Intensities

$lux = 32912 / distance(m)^2$

$fc = 32912 / distance(ft)^2$

Color Details

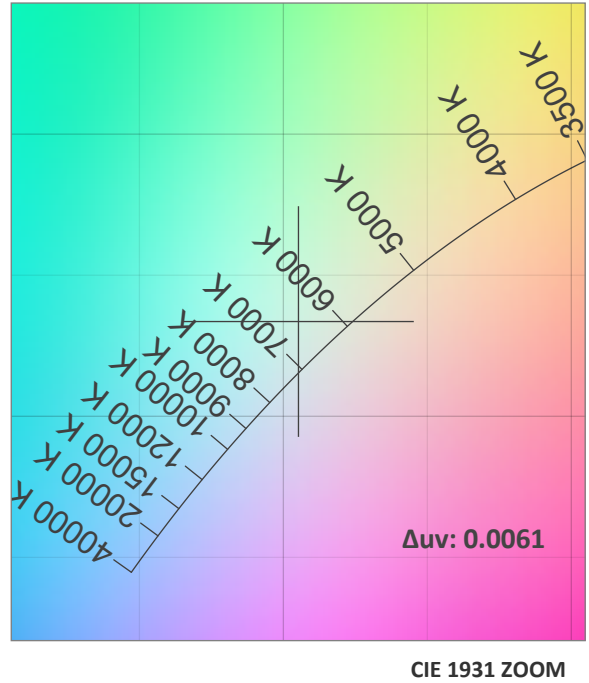
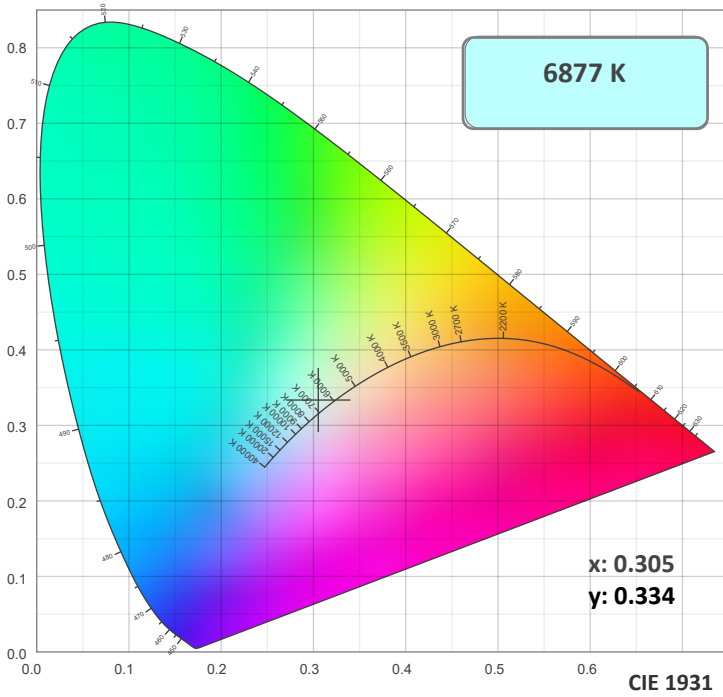

TM30: 88.8

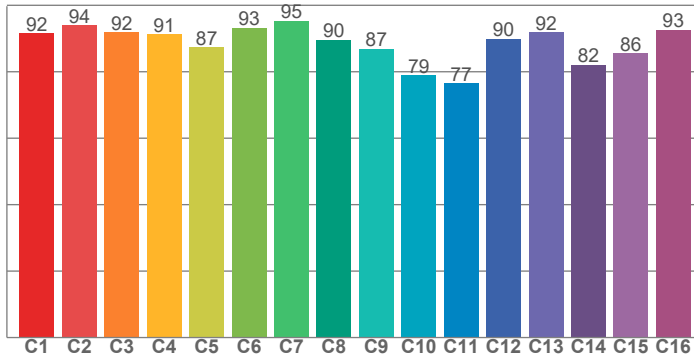

CRI: 90.6 (R1-R8)

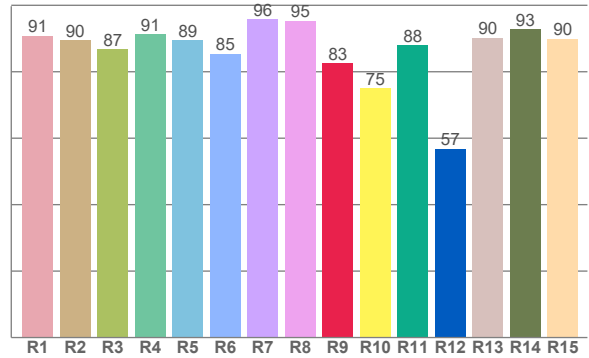

CRI R values, only R1-R8 are used to calculate final CRI value

R1	R2	R3	R4	R5	R6	R7	R8	R9	R10	R11	R12	R13	R14	R15
90.9	89.6	86.9	91.3	89.4	85.4	95.7	95.4	82.7	75.0	88.1	56.8	90.2	92.8	89.9

TM30 C Values, 16 binned values out of total of 99 C values

C1	C2	C3	C4	C5	C6	C7	C8	C9	C10	C11	C12	C13	C14	C15	C16
91.6	93.9	91.8	91.2	87.3	93.3	95.3	89.7	86.9	78.9	76.5	89.8	91.8	82.1	85.6	92.6

CQS Q Values

Q1	Q2	Q3	Q4	Q5	Q6	Q7	Q8	Q9	Q10	Q11	Q12	Q13	Q14	Q15
95.7	98.6	81.7	81.1	87.9	90.1	90.5	96.0	94.3	91.0	93.3	94.6	94.8	96.0	96.8

CQS: 90.7

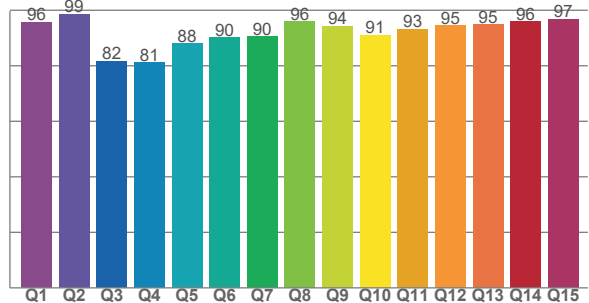

Color Parameters

Color Temperature	Color Rendering Index	Red Component	Color Fidelity	Color Gamut	Color Quality Scale	Color Coordinate CIE 1931	Color Coordinate CIE 1931	Color Coordinate	Color Coordinate	Color Diviation from Black
CCT	CRI	CRI R9	TM30 Rf	TM30 Rg	CQS	x	y	u	v	Δuv
6877 K	90.6	82.7	88.8	99.5	90.7	0.305	0.334	0.191	0.313	0.0061

TM30 Details

Rf 88.8
Fidelity Index Rf

Rg 99.5
Gamut Index Rg

Hue Bin	R _f	Graphic shifts (%)	
		Chroma	Hue
1	92	-2%	-1%
2	94	-3%	1%
3	92	-2%	2%
4	91	-1%	4%
5	87	-4%	2%
6	93	1%	0%
7	95	-1%	-2%
8	90	-5%	0%
9	87	-7%	8%
10	79	-4%	14%
11	77	1%	14%
12	90	3%	6%
13	92	6%	2%
14	82	14%	-5%
15	86	7%	-8%
16	93	0%	-4%

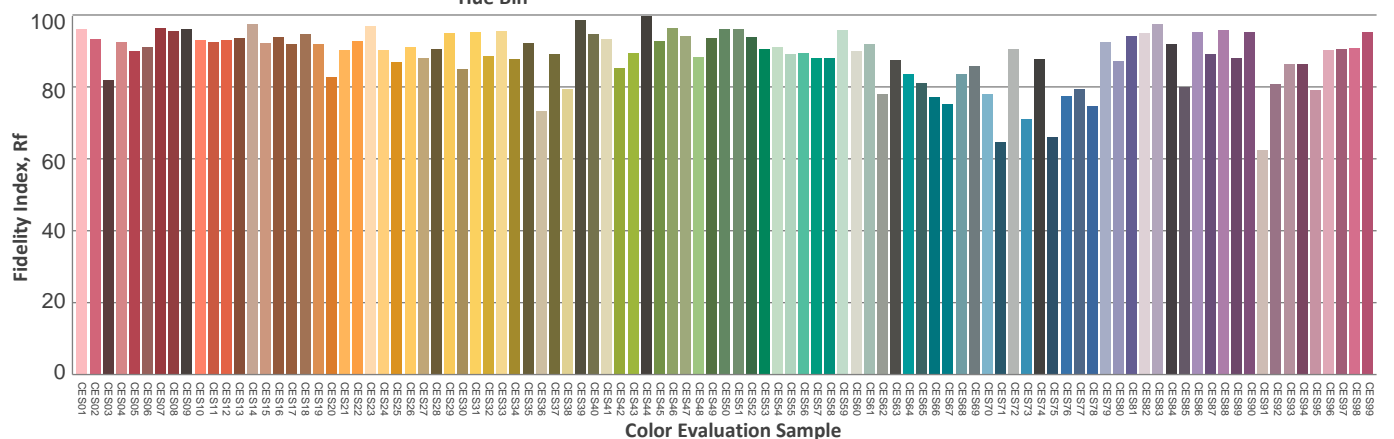
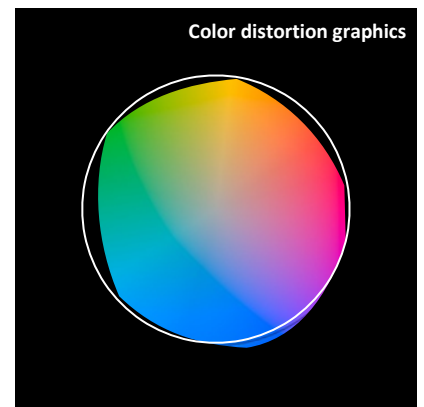
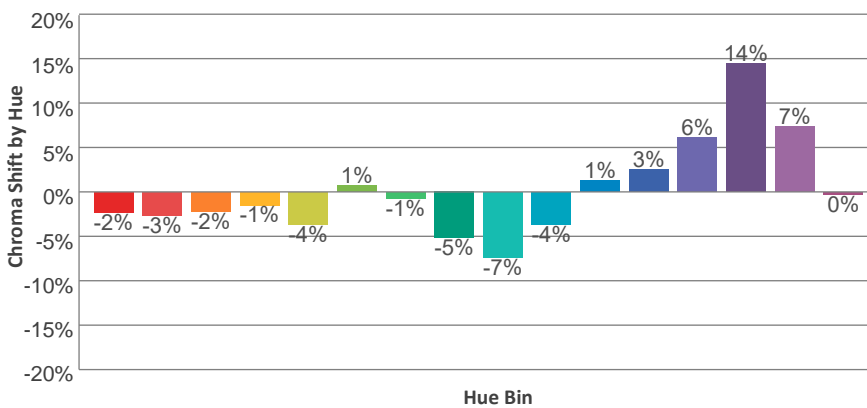
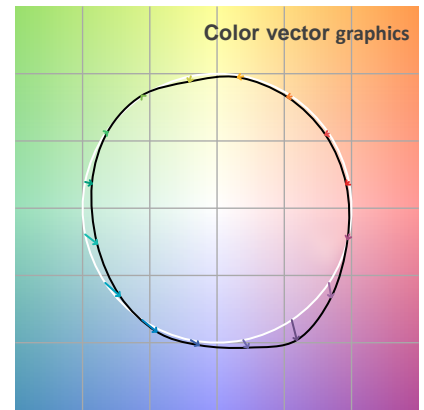
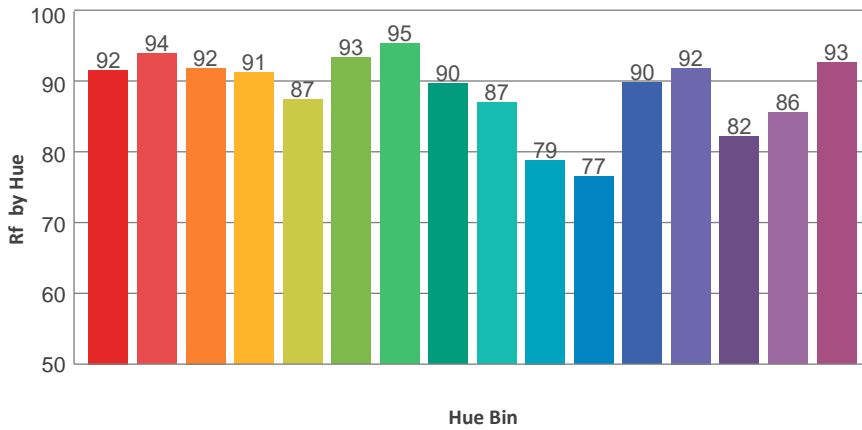
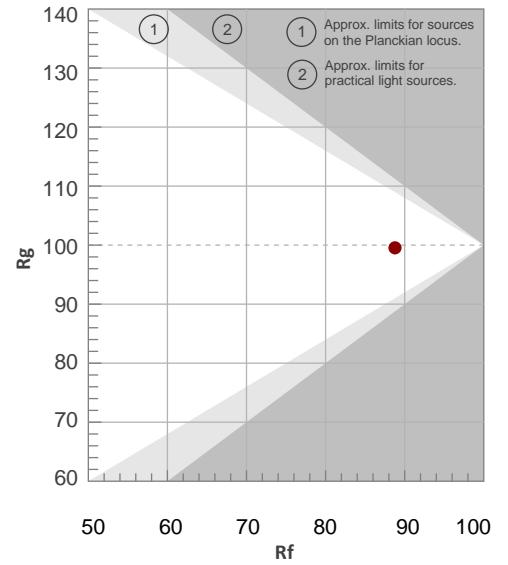

ISO Diagrams

ISO Candela Diagram

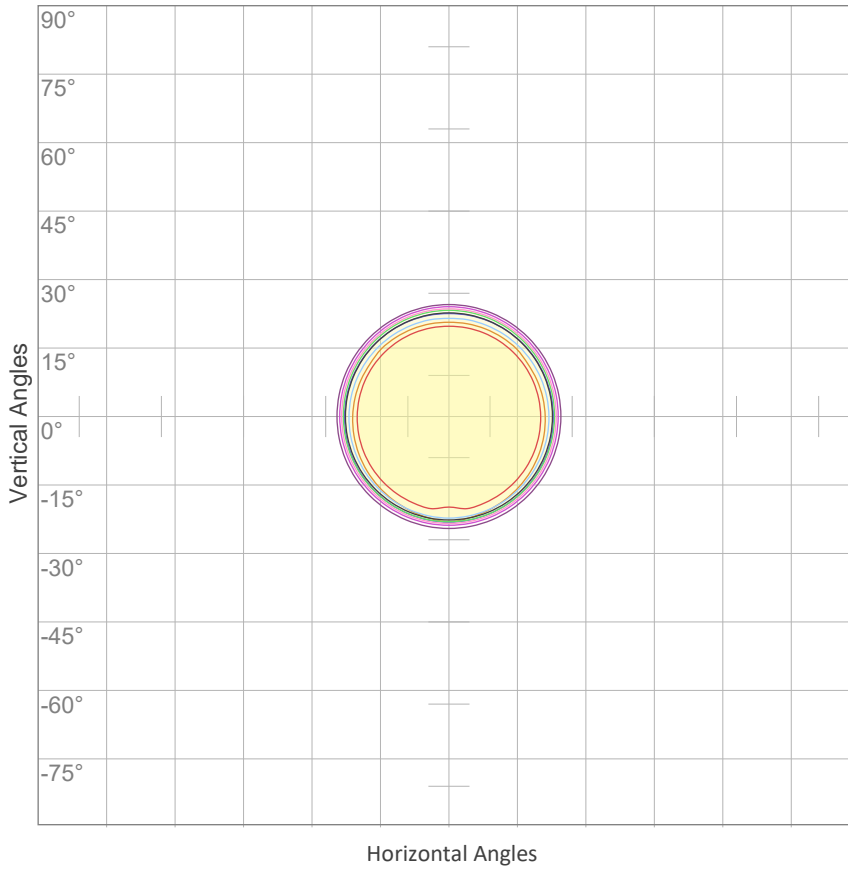

10%	3278 cd
20%	6556 cd
30%	9835 cd
40%	13113 cd
50%	16391 cd
60%	19669 cd
70%	22947 cd
80%	26225 cd
90%	29504 cd

Conditions:
 Number of c-planes: 2
 Candela at center: 32782 cd

ISO Lux Diagram

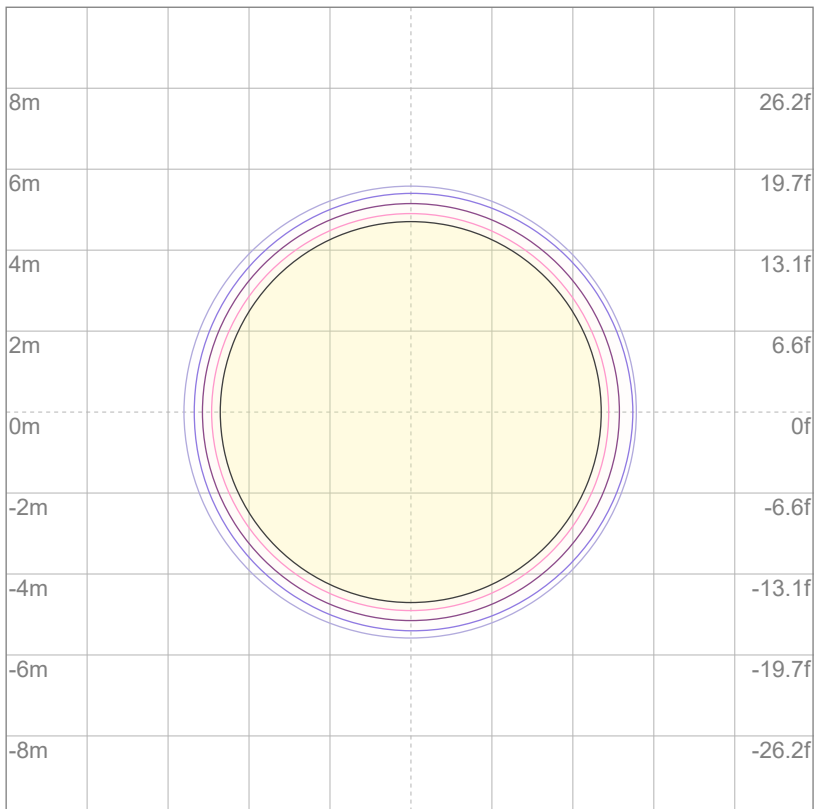

3%	9.83 lx
5%	16.4 lx
10%	32.8 lx
30%	98.3 lx
50%	164 lx

Conditions:
 Number of c-planes: 2
 Lux at center: 328 lx

Lux distribution on a surface when lamp is mounted at 10 meters from the surface.

Mounting Height: 10 meters (33 feet)

Photometric Report

Total Lumen Output*

Integrating Sphere 21065 lm

VISO Lab Spion 18637 lm

Beam Angle 50%	Field Angle 10%	Cutoff Angle 2.5%
19.6°	21.3°	21.8°

Color Temperature: 6877 K

CRI: 90.9

TLCI: 95

TM30: 88.9

CQS: 90.8

Voltage: 119 V, Current: 8.86 A

Power: 1054 W

Efficacy: 18 Lumen/Watt

Measurement Date: 3/18/2022

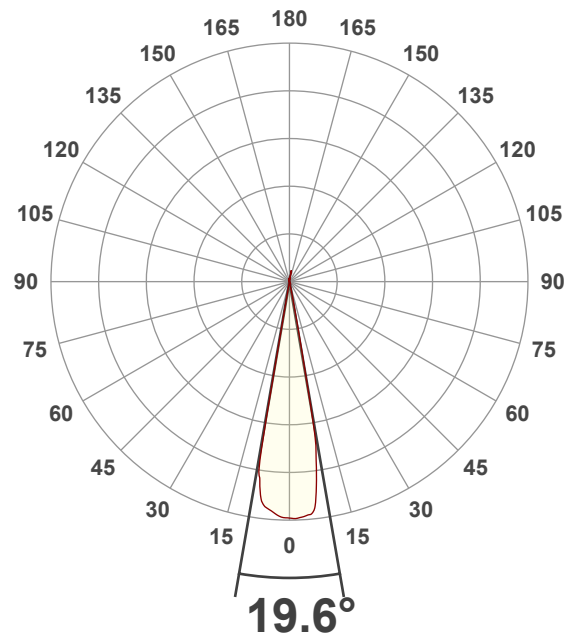

Spectral Distribution

Dominant Wavelength 498 nm

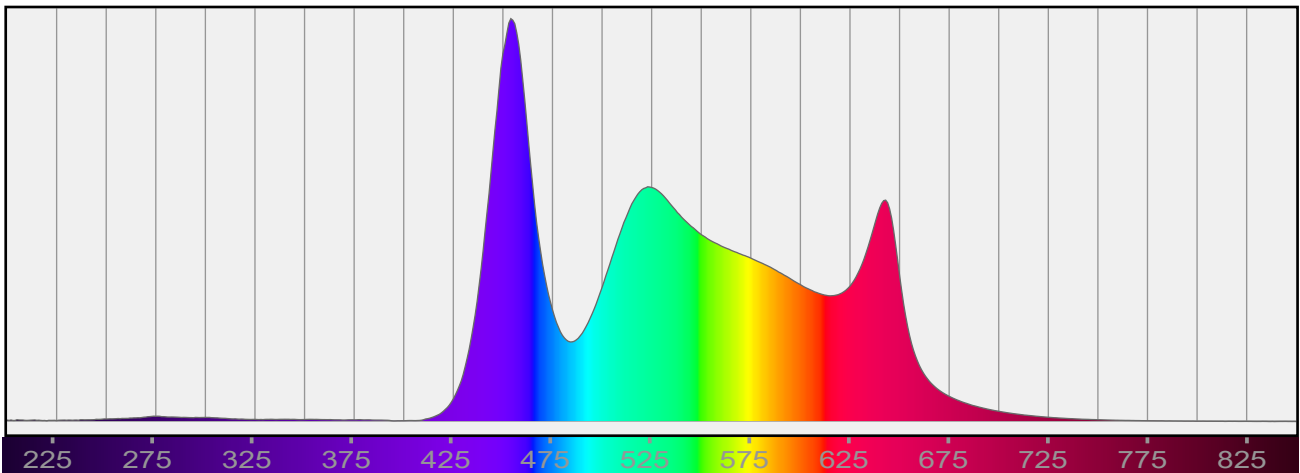

*Total Lumen measurements by calibrated Everfine 2π Integrating Sphere and Viso Systems Lab Spion

Beam Details

Beam Angle 50%	Field Angle 10%	Cutoff Angle 2,5%
19.6°	21.3°	21.8°

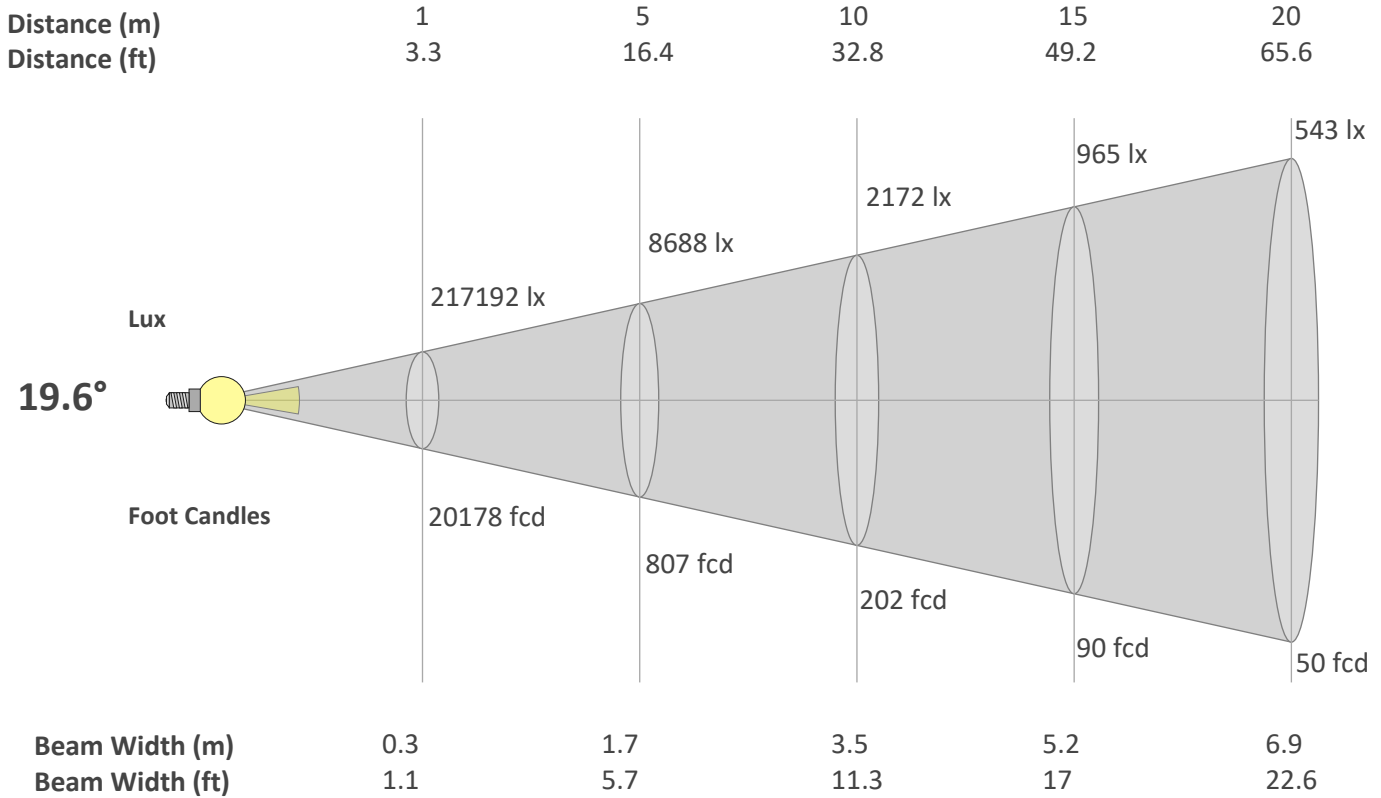

Beam Intensities from 1-20m

M	1	2	3	4	5	6	7	8	9	10	11	12	13	14	15	16	17	18	19	20
FT	3.3	6.6	9.8	13.1	16.4	19.7	23	26.2	29.5	32.8	36.1	39.4	42.7	45.9	49.2	52.5	55.8	59.1	62.3	65.6
LX	217192	54298	24132	13574	8688	6033	4432	3394	2681	2172	1795	1508	1285	1108	965	848	752	670	602	543
FC	20177.8	5044.4	2242	1261.1	807.1	560.5	411.8	315.3	249.1	201.8	166.8	140.1	119.4	102.9	89.7	78.8	69.8	62.3	55.9	50.4

Linear Distribution

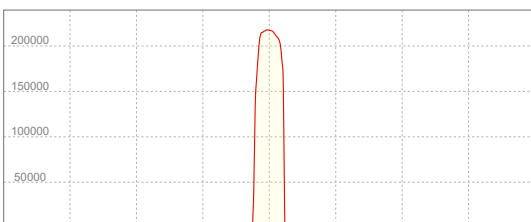

Peak Candela
217744 cd

Calculate Center Beam Intensities
lux = 217744 / distance(m)²
fc = 217744 / distance(ft)²

Color Details

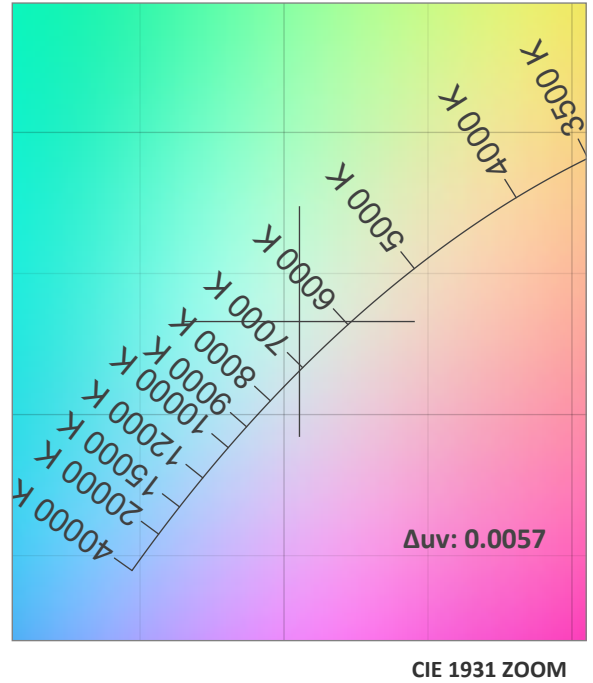
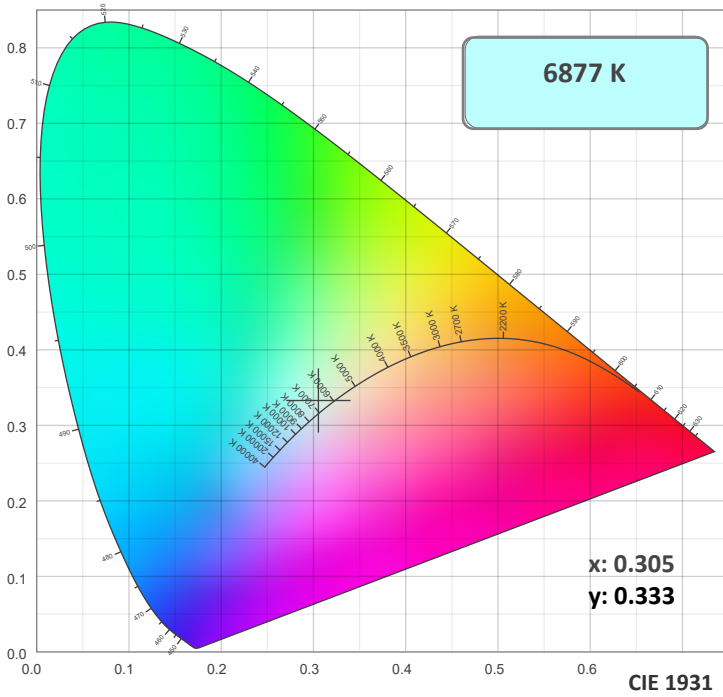

TM30: 88.9

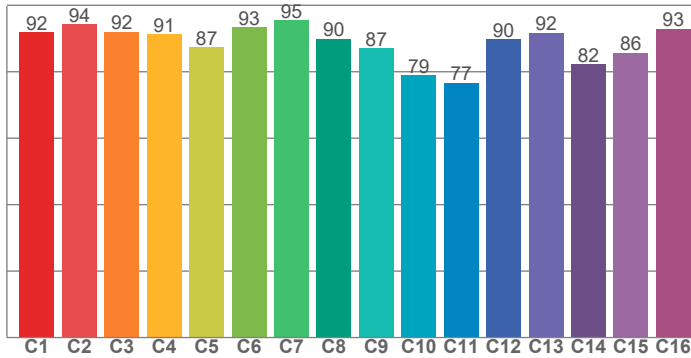

CRI: 90.9 (R1-R8)

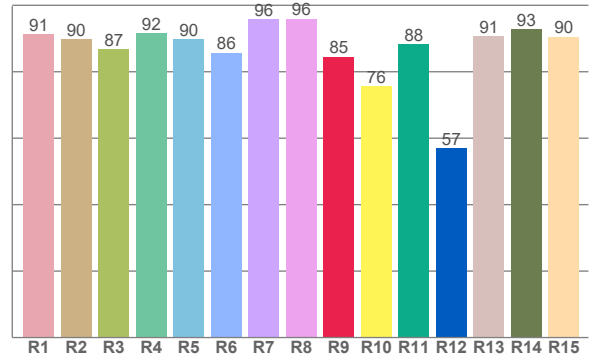

CRI R values, only R1-R8 are used to calculate final CRI value

R1	R2	R3	R4	R5	R6	R7	R8	R9	R10	R11	R12	R13	R14	R15
91.4	89.8	86.8	91.7	89.8	85.7	95.8	95.9	84.5	75.6	88.3	57.1	90.7	92.8	90.5

TM30 C Values, 16 binned values out of total of 99 C values

C1	C2	C3	C4	C5	C6	C7	C8	C9	C10	C11	C12	C13	C14	C15	C16
91.9	94.2	92.0	91.3	87.3	93.3	95.5	89.9	87.1	78.9	76.6	89.8	91.8	82.3	85.7	92.8

CQS Q Values

Q1	Q2	Q3	Q4	Q5	Q6	Q7	Q8	Q9	Q10	Q11	Q12	Q13	Q14	Q15
95.9	98.5	81.7	81.1	88.1	90.4	90.6	96.2	94.2	91.1	93.3	94.7	95.1	96.5	97.2

CQS: 90.8

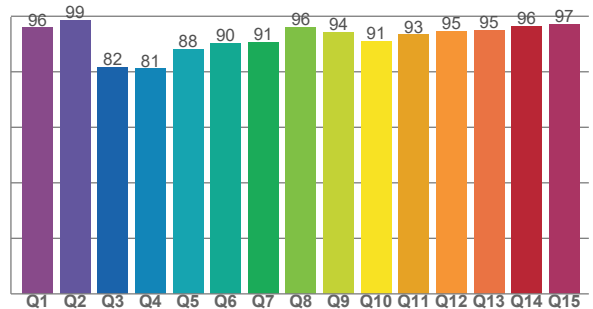

Color Parameters

Color Temperature	Color Rendering Index	Red Component	Color Fidelity	Color Gamut	Color Quality Scale	Color Coordinate CIE 1931	Color Coordinate CIE 1931	Color Coordinate	Color Coordinate	Color Diviation from Black
CCT	CRI	CRI R9	TM30 Rf	TM30 Rg	CQS	x	y	u	v	Δuv
6877 K	90.9	84.5	88.9	99.7	90.8	0.305	0.333	0.191	0.313	0.0057

TM30 Details

Rf 88.9
Fidelity Index Rf

Rg 99.7
Gamut Index Rg

Hue Bin	R _f	Graphic shifts (%)	
		Chroma	Hue
1	92	-2%	-1%
2	94	-2%	1%
3	92	-2%	2%
4	91	-1%	4%
5	87	-4%	2%
6	93	1%	0%
7	95	-1%	-2%
8	90	-5%	0%
9	87	-7%	8%
10	79	-4%	14%
11	77	1%	13%
12	90	2%	7%
13	92	6%	2%
14	82	14%	-5%
15	86	8%	-8%
16	93	0%	-3%

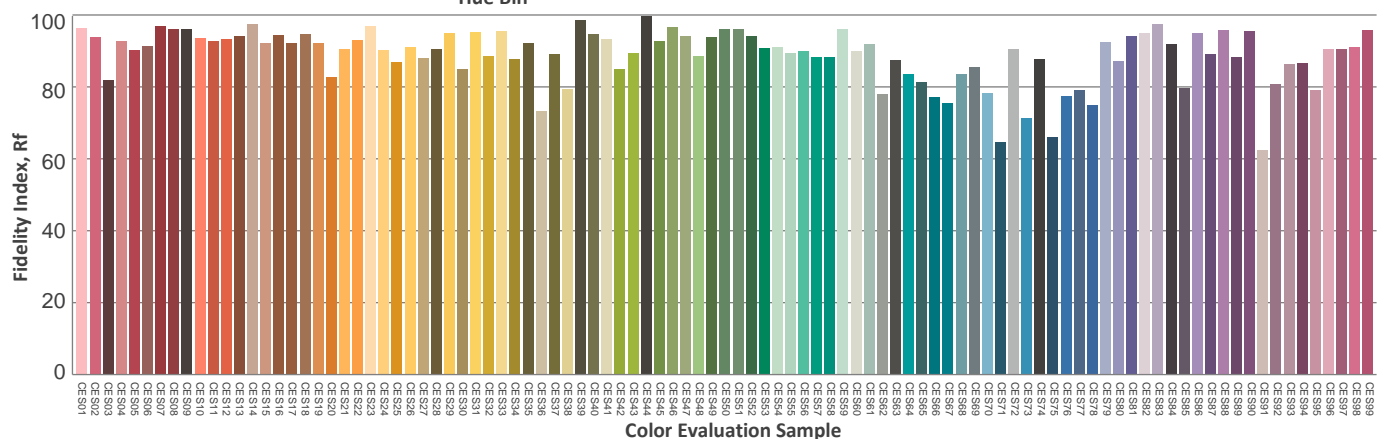
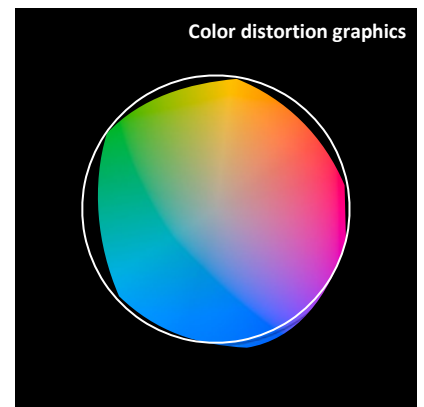
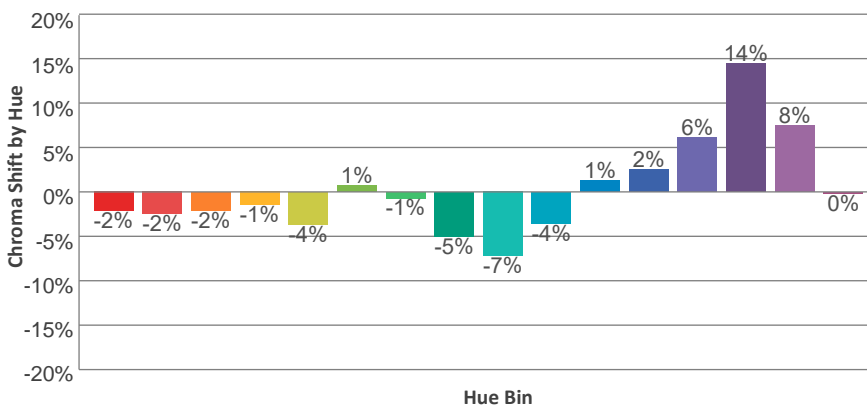
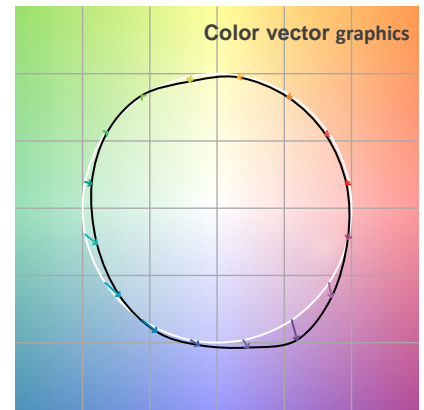
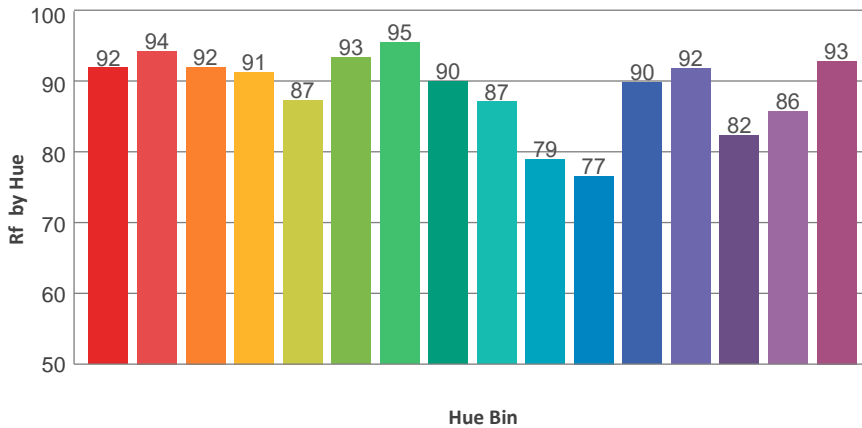
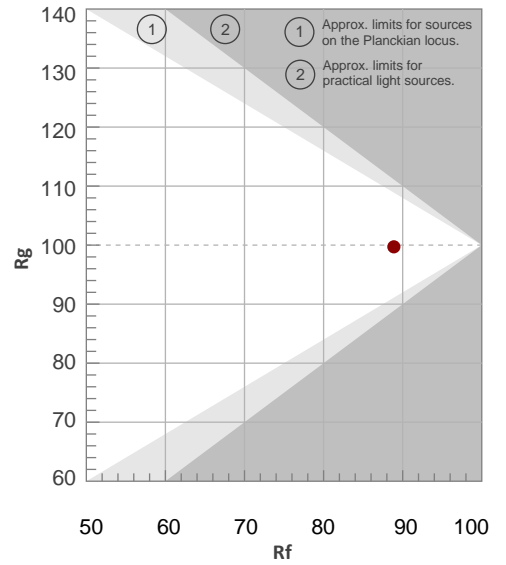

Photometric Report

Total Lumen Output*

Integrating Sphere 7562 lm

VISO Lab Spion 8911 lm

Beam Angle 50%	Field Angle 10%	Cutoff Angle 2.5%
6.6°	7.8°	8.7°

Color Temperature: 6718 K

CRI: 91.7

TLCI: 95

TM30: 89.4

CQS: 91.2

Voltage: 121 V, Current: 8.74 A

Power: 1055 W

Efficacy: 8 Lumen/Watt

Measurement Date: 3/18/2022

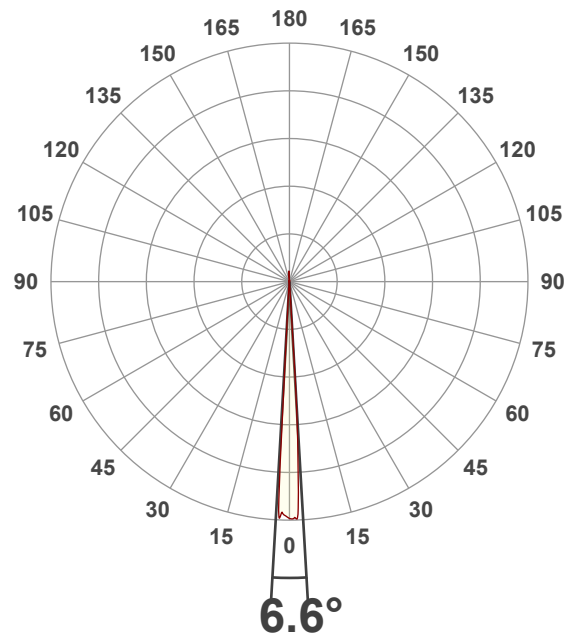

Spectral Distribution

Dominant Wavelength 504 nm

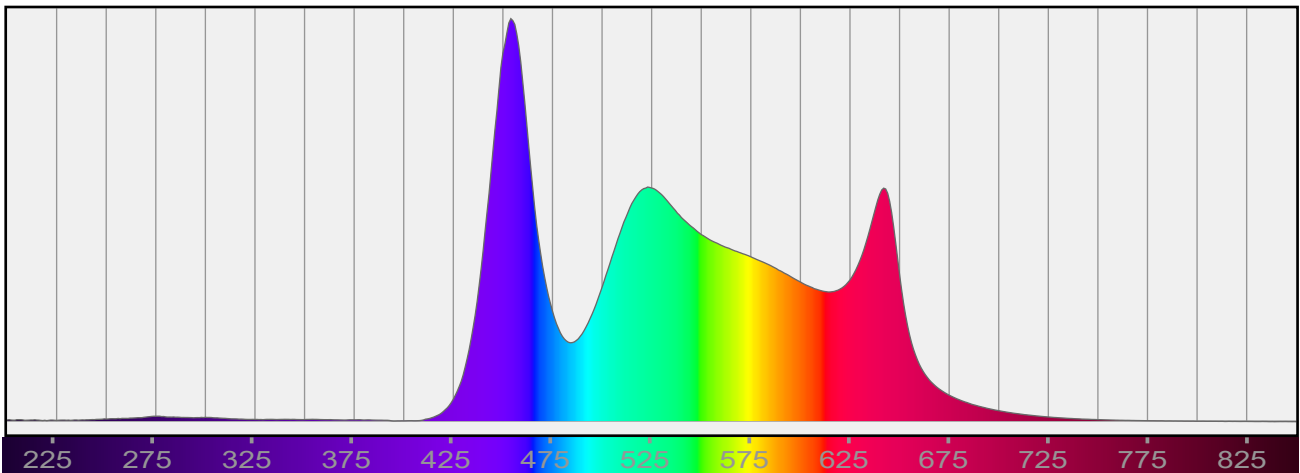

*Total Lumen measurements by calibrated Everfine 2π Integrating Sphere and Viso Systems Lab Spion

Beam Details

Beam Angle 50%	Field Angle 10%	Cutoff Angle 2,5%
6.6°	7.8°	8.7°

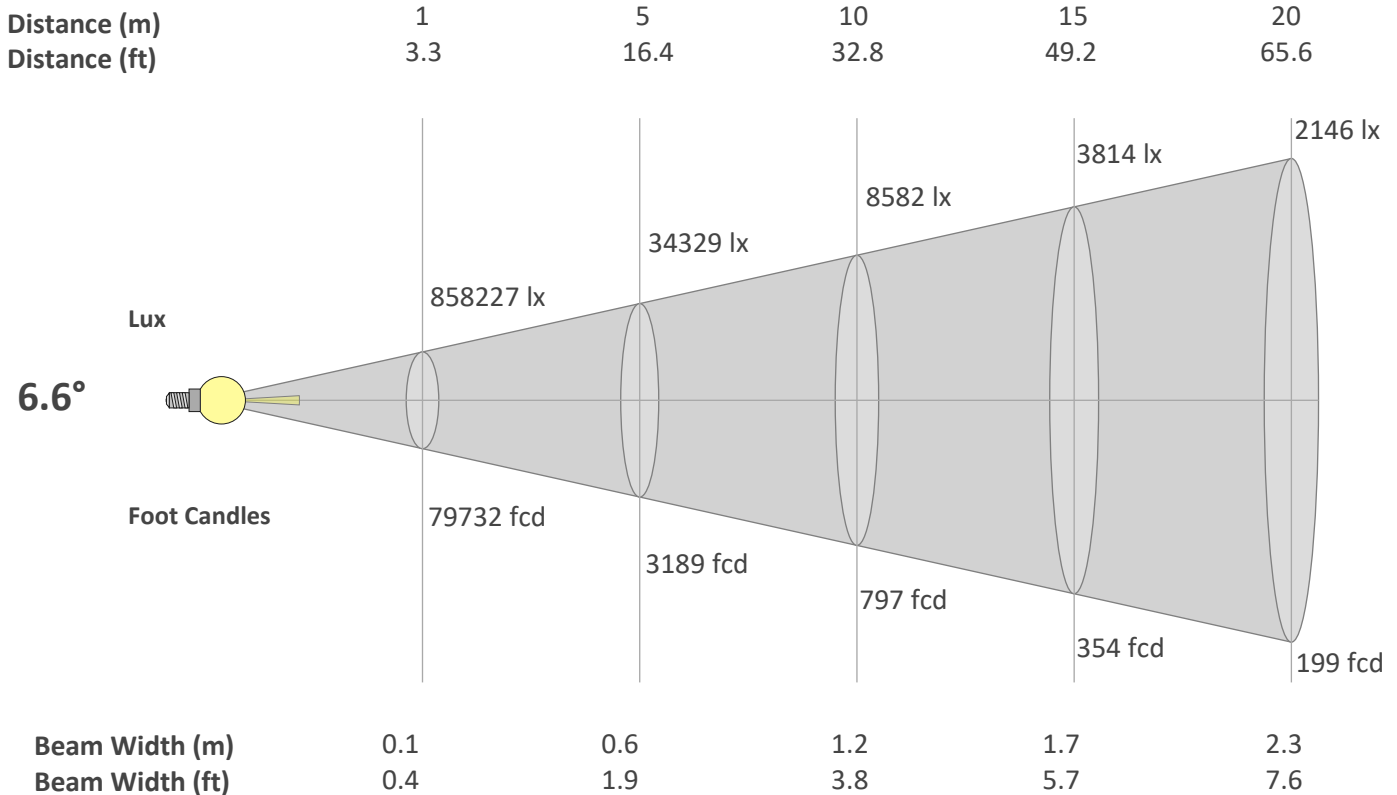

Beam Intensities from 1-20m

M	1	2	3	4	5	6	7	8	9	10	11	12	13	14	15	16	17	18	19	20
FT	3.3	6.6	9.8	13.1	16.4	19.7	23	26.2	29.5	32.8	36.1	39.4	42.7	45.9	49.2	52.5	55.8	59.1	62.3	65.6
LX	858227	214557	95359	53639	34329	23840	17515	13410	10595	8582	7093	5960	5078	4379	3814	3352	2970	2649	2377	2146
FC	79731.9	19933	8859.1	4983.2	3189.3	2214.8	1627.2	1245.8	984.3	797.3	658.9	553.7	471.8	406.8	354.4	311.5	275.9	246.1	220.9	199.3

Linear Distribution

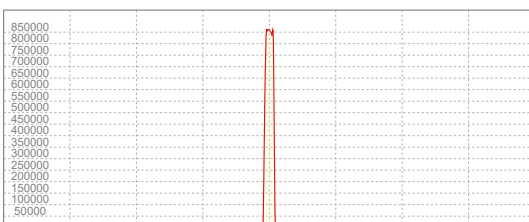

Peak Candela
860025 cd

Calculate Center Beam Intensities
 $lux = 860025 / distance(m)^2$
 $fc = 860025 / distance(ft)^2$

Color Details

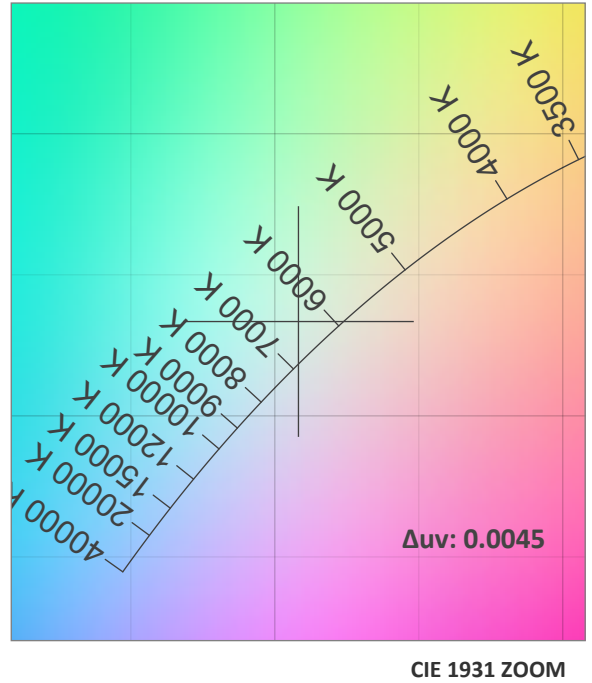
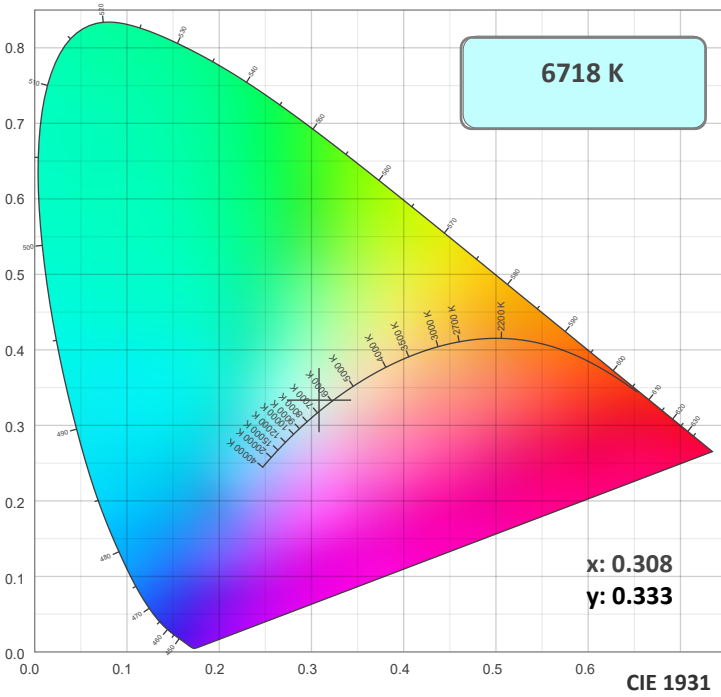

TM30: 89.4

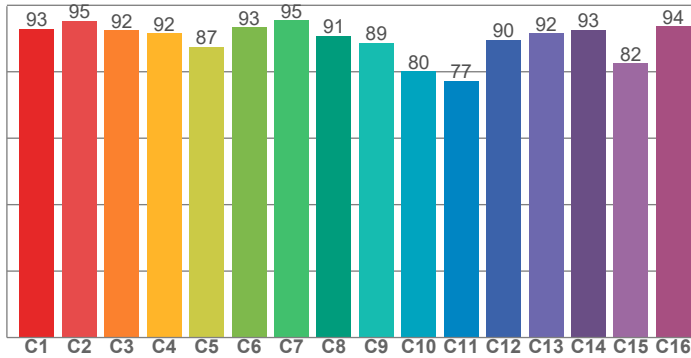

CRI: 91.7 (R1-R8)

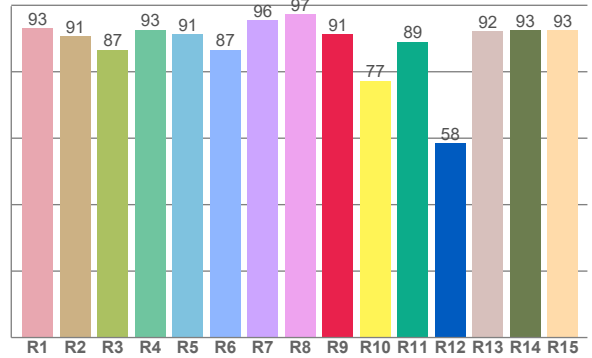

CRI R values, only R1-R8 are used to calculate final CRI value

R1	R2	R3	R4	R5	R6	R7	R8	R9	R10	R11	R12	R13	R14	R15
93.1	90.7	86.6	92.7	91.4	86.6	95.5	97.3	91.3	77.3	89.1	58.5	92.2	92.5	92.6

TM30 C Values, 16 binned values out of total of 99 C values

C1	C2	C3	C4	C5	C6	C7	C8	C9	C10	C11	C12	C13	C14	C15	C16
93.0	95.3	92.5	91.5	87.5	93.4	95.5	90.9	88.6	80.1	77.2	89.7	91.6	92.6	82.5	93.6

CQS Q Values

Q1	Q2	Q3	Q4	Q5	Q6	Q7	Q8	Q9	Q10	Q11	Q12	Q13	Q14	Q15
96.8	98.4	81.6	81.8	89.1	91.5	91.2	96.9	93.8	91.2	93.7	95.4	95.9	98.1	98.6

CQS: 91.2

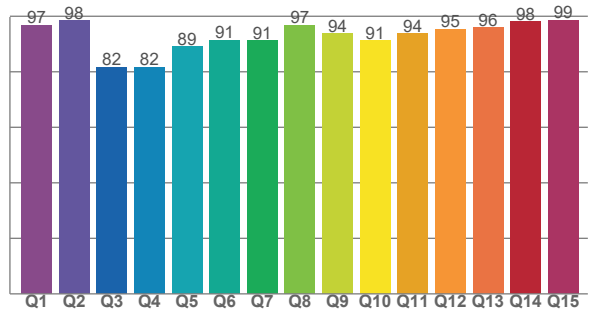

Color Parameters

Color Temperature	Color Rendering Index	Red Component	Color Fidelity	Color Gamut	Color Quality Scale	Color Coordinate CIE 1931	Color Coordinate CIE 1931	Color Coordinate	Color Coordinate	Color Diviation from Black
CCT	CRI	CRI R9	TM30 Rf	TM30 Rg	CQS	x	y	u	v	Δuv
6718 K	91.7	91.3	89.4	99.8	91.2	0.308	0.333	0.193	0.313	0.0045

TM30 Details

Rf 89.4
Fidelity Index Rf

Rg 99.8
Gamut Index Rg

Hue Bin	R _f	Graphic shifts (%)	
		Chroma	Hue
1	93	-1%	-1%
2	95	-2%	1%
3	92	-2%	2%
4	92	-1%	4%
5	87	-3%	2%
6	93	1%	1%
7	95	0%	-2%
8	91	-4%	0%
9	89	-6%	8%
10	80	-4%	14%
11	77	1%	13%
12	90	2%	7%
13	92	6%	3%
14	93	3%	-2%
15	82	13%	-10%
16	94	0%	-3%

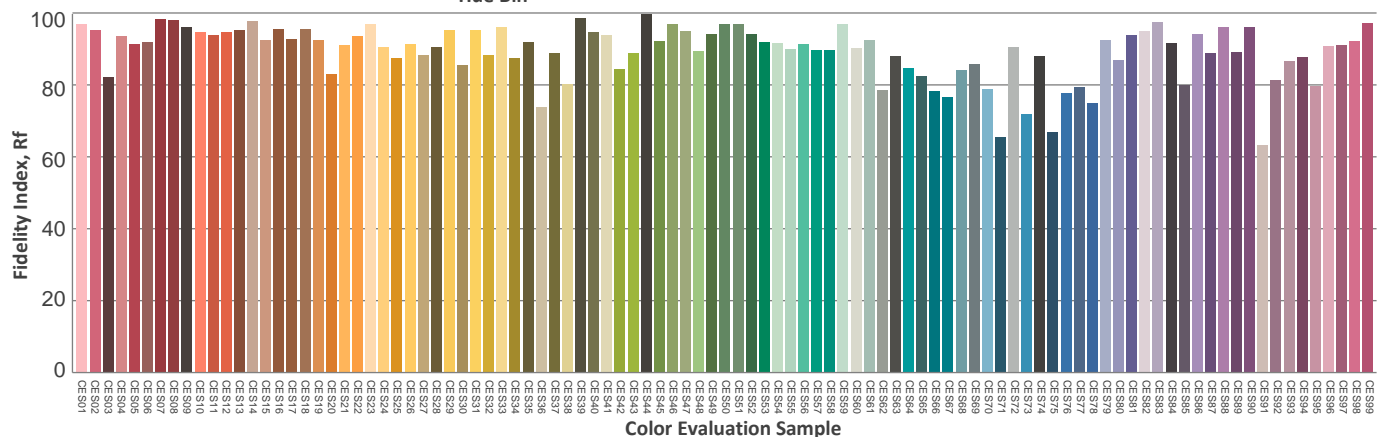
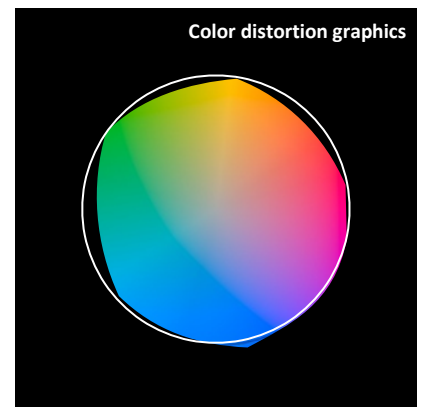
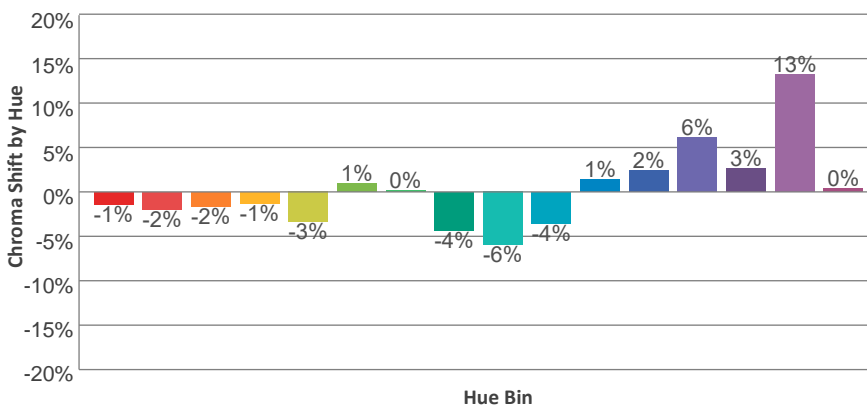
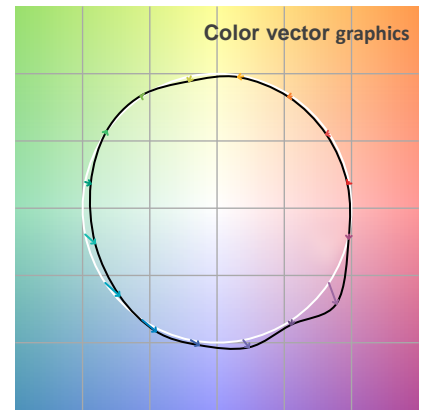
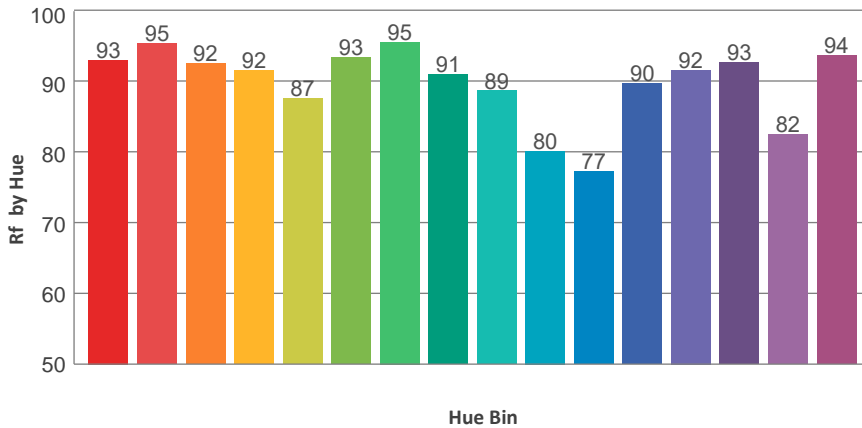
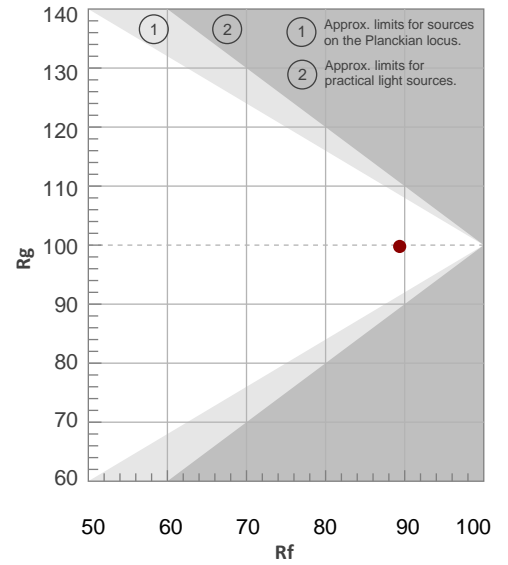

ISO Diagrams

ISO Candela Diagram

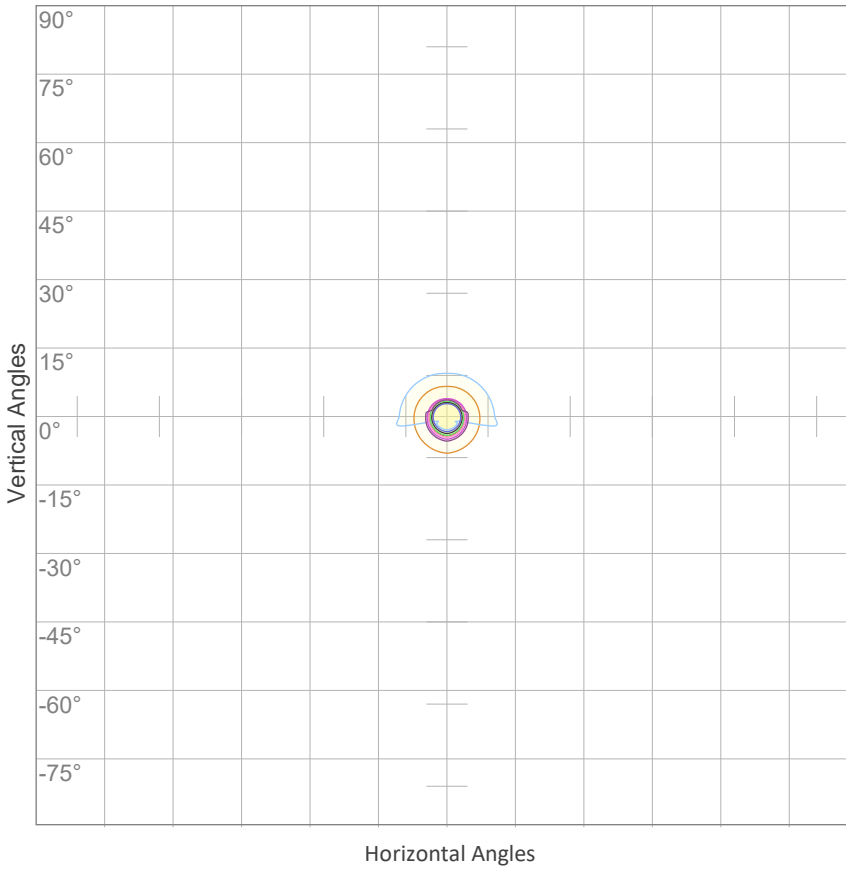

10%	85823 cd
20%	171645 cd
30%	257468 cd
40%	343291 cd
50%	429114 cd
60%	514936 cd
70%	600759 cd
80%	686582 cd
90%	772405 cd

Conditions:

Number of c-planes: 2

Candela at center: 858227 cd

ISO Lux Diagram

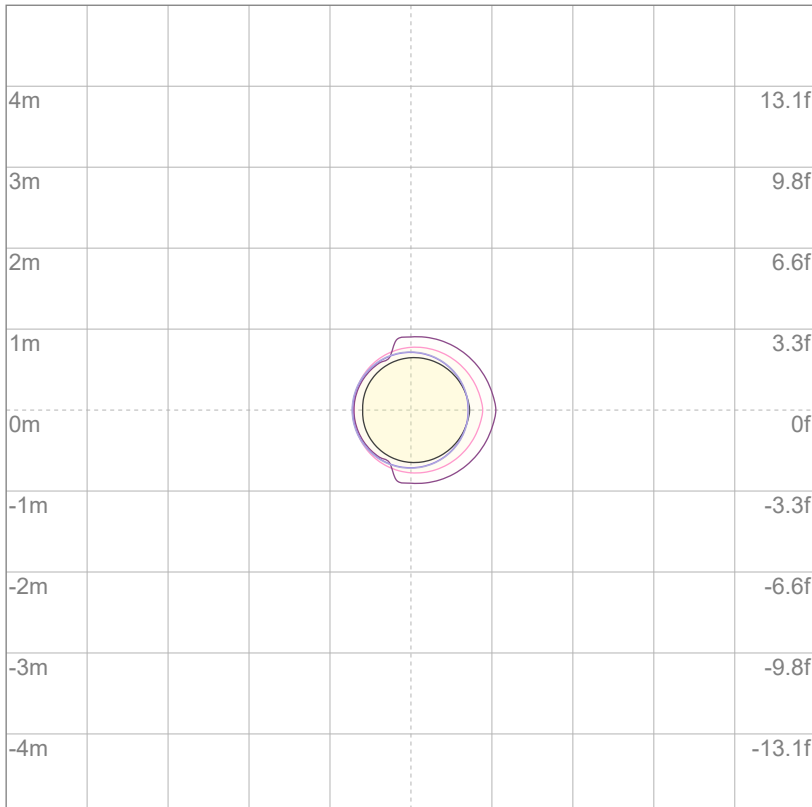

3%	257 lx
5%	429 lx
10%	858 lx
30%	2575 lx
50%	4291 lx

Conditions:

Number of c-planes: 2

Lux at center: 8582 lx

Lux distribution on a surface when lamp is mounted at 10 meters from the surface.

Mounting Height: 10 meters (33 feet)

ISO Diagrams

ISO Candela Diagram

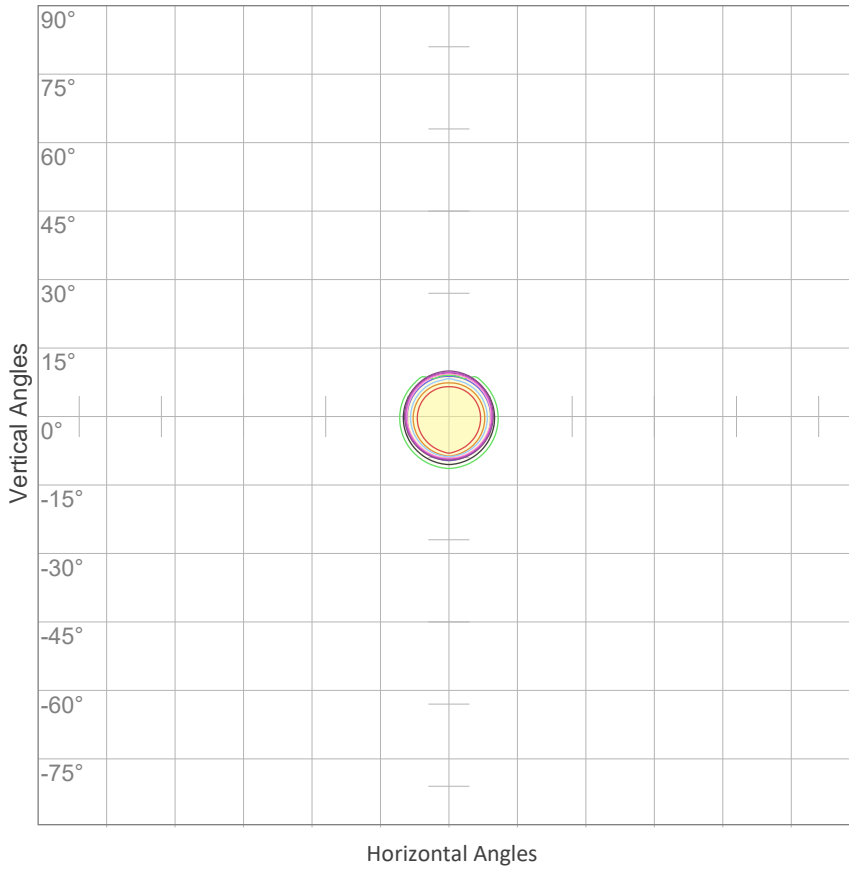

10%	21719 cd
20%	43438 cd
30%	65158 cd
40%	86877 cd
50%	108596 cd
60%	130315 cd
70%	152034 cd
80%	173753 cd
90%	195473 cd

Conditions:
 Number of c-planes: 2
 Candela at center: 217192 cd

ISO Lux Diagram

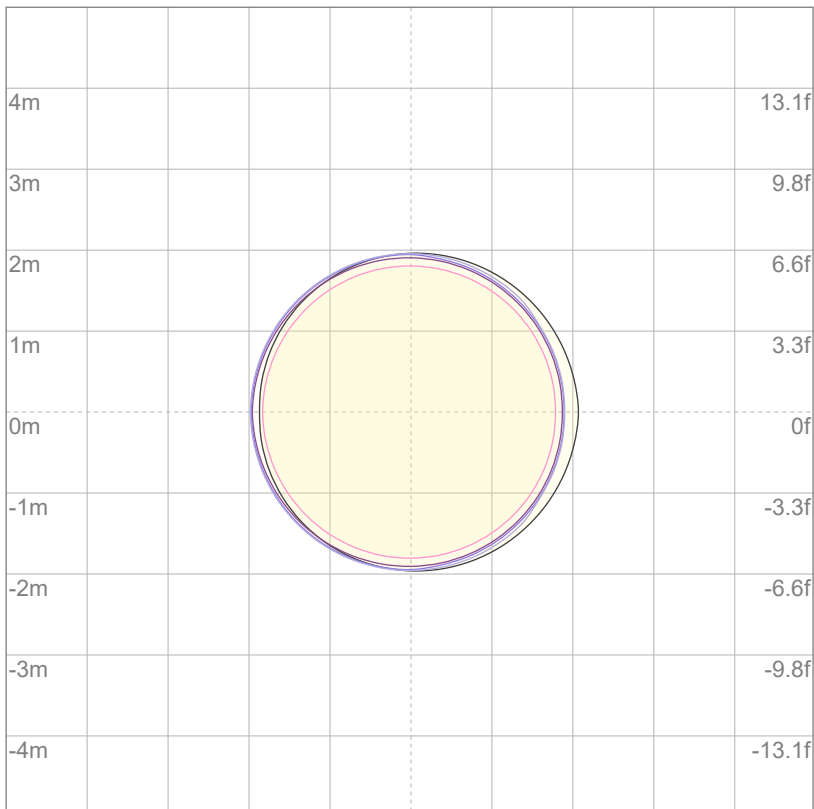

3%	65.2 lx
5%	109 lx
10%	217 lx
30%	652 lx
50%	1086 lx

Conditions:
 Number of c-planes: 2
 Lux at center: 2172 lx

Lux distribution on a surface when lamp is mounted at 10 meters from the surface.

Mounting Height: 10 meters (33 feet)

Photometric Report

Total Lumen Output*

VISO Lab Spion 7805 lm

Beam Angle 50%	Field Angle 10%	Cutoff Angle 2.5%
19.7°	21.7°	22.6°

Color Temperature: 2776 K

CRI: 93.2

TLCI: 89

TM30: 94.0

CQS: 92.1

Voltage: 120 V, Current: 3.76 A

Power: 452 W

Efficacy: 17 Lumen/Watt

Measurement Date: 3/18/2022

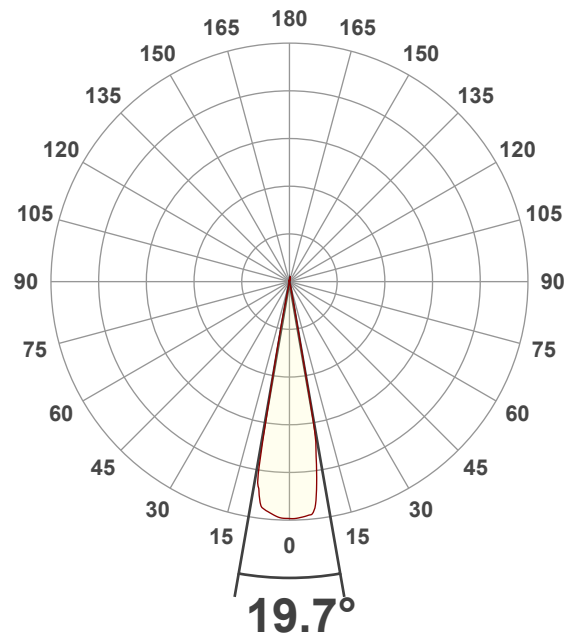

Spectral Distribution

Dominant Wavelength 583 nm

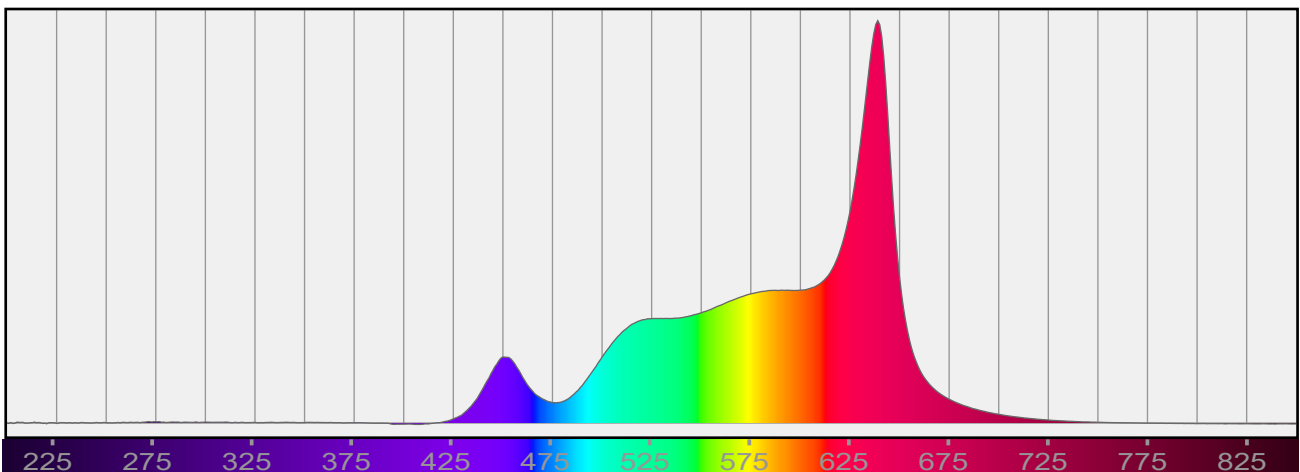

*Total Lumen measurements by calibrated Everfine 2π Integrating Sphere and Viso Systems Lab Spion

Beam Details

Beam Angle 50%	Field Angle 10%	Cutoff Angle 2,5%
19.7°	21.7°	22.6°

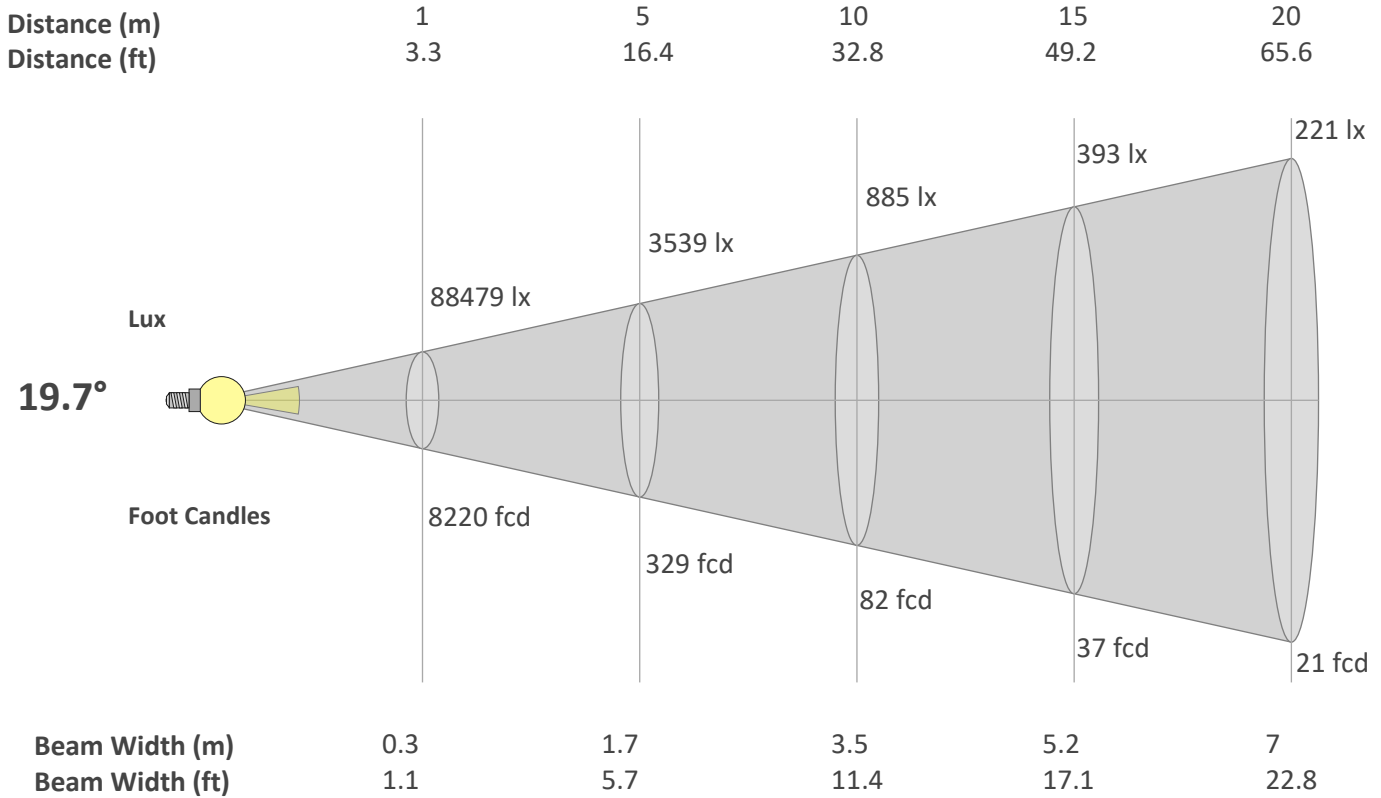

Beam Intensities from 1-20m

M	1	2	3	4	5	6	7	8	9	10	11	12	13	14	15	16	17	18	19	20
FT	3.3	6.6	9.8	13.1	16.4	19.7	23	26.2	29.5	32.8	36.1	39.4	42.7	45.9	49.2	52.5	55.8	59.1	62.3	65.6
LX	88479	22120	9831	5530	3539	2458	1806	1382	1092	885	731	614	524	451	393	346	306	273	245	221
FC	8220	2055	913.3	513.7	328.8	228.3	167.8	128.4	101.5	82.2	67.9	57.1	48.6	41.9	36.5	32.1	28.4	25.4	22.8	20.5

Linear Distribution

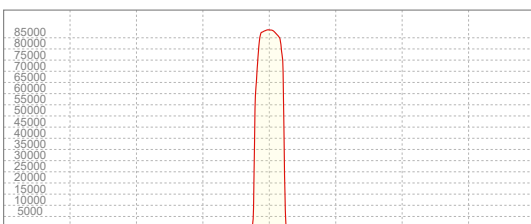

Peak Candela

88541 cd

Calculate Center Beam Intensities

lux = 88541 / distance(m)²

fc = 88541 / distance(ft)²

Color Details

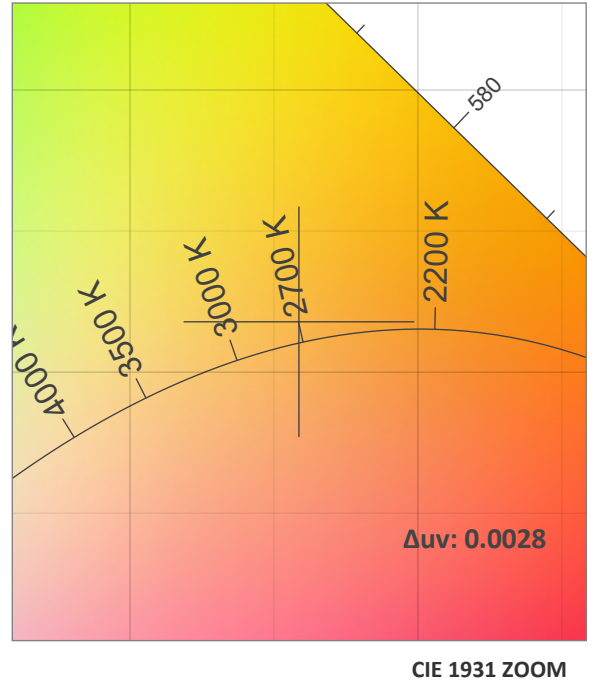
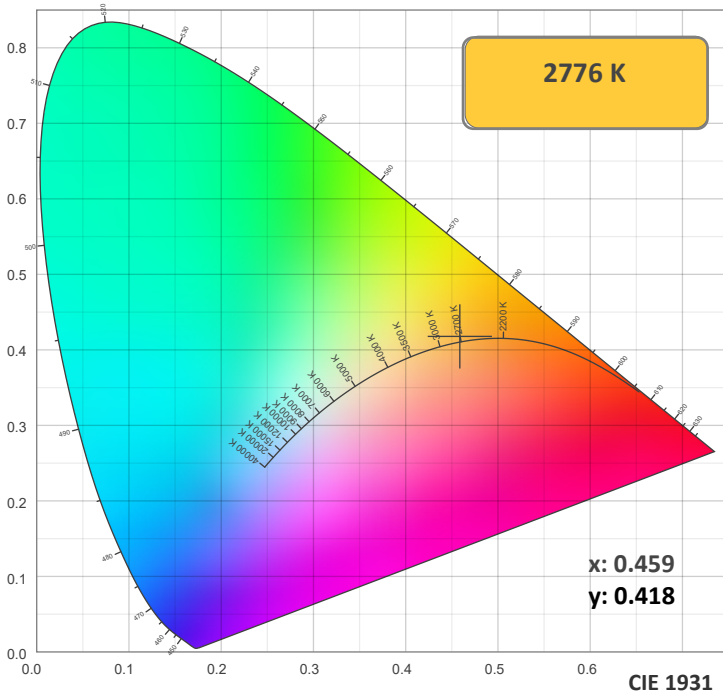

TM30: 94.0

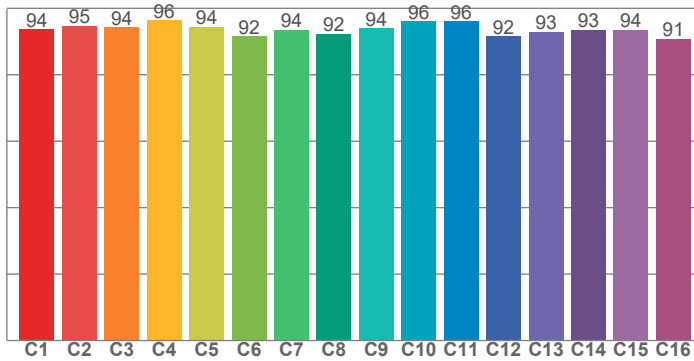

CRI: 93.2 (R1-R8)

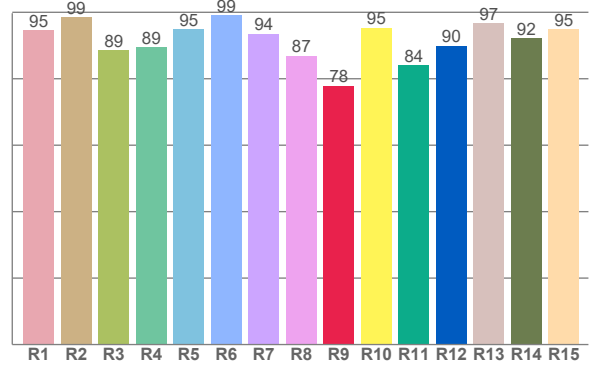

CRI R values, only R1-R8 are used to calculate final CRI value

R1	R2	R3	R4	R5	R6	R7	R8	R9	R10	R11	R12	R13	R14	R15
94.6	98.6	88.7	89.4	94.9	99.1	93.6	86.9	77.9	95.4	84.1	89.9	96.8	92.2	95.0

TM30 C Values, 16 binned values out of total of 99 C values

C1	C2	C3	C4	C5	C6	C7	C8	C9	C10	C11	C12	C13	C14	C15	C16
93.7	94.7	94.2	96.4	94.5	91.6	93.6	92.3	94.0	96.0	96.1	91.6	92.9	93.5	93.5	90.8

CQS Q Values

Q1	Q2	Q3	Q4	Q5	Q6	Q7	Q8	Q9	Q10	Q11	Q12	Q13	Q14	Q15
96.0	94.8	94.6	94.8	90.3	88.0	94.7	94.0	93.1	91.4	88.8	89.6	90.5	94.9	96.6

CQS: 92.1

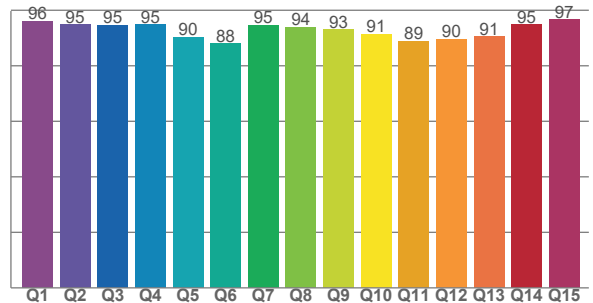

Color Parameters

Color Temperature	Color Rendering Index	Red Component	Color Fidelity	Color Gamut	Color Quality Scale	Color Coordinate CIE 1931	Color Coordinate CIE 1931	Color Coordinate	Color Coordinate	Color Diviation from Black
CCT	CRI	CRI R9	TM30 Rf	TM30 Rg	CQS	x	y	u	v	Δuv
2776 K	93.2	77.9	94.0	103.7	92.1	0.459	0.418	0.259	0.353	0.0028

TM30 Details

Rf 94.0
Fidelity Index Rf

Rg 103.7
Gamut Index Rg

Hue Bin	R _f	Graphic shifts (%)	
		Chroma	Hue
1	94	2%	-2%
2	95	1%	-3%
3	94	0%	-1%
4	96	-1%	-1%
5	94	0%	4%
6	92	4%	4%
7	94	4%	1%
8	92	5%	-1%
9	94	2%	-3%
10	96	1%	-1%
11	96	1%	1%
12	92	4%	-2%
13	93	2%	-5%
14	93	4%	-1%
15	94	2%	-1%
16	91	4%	-6%

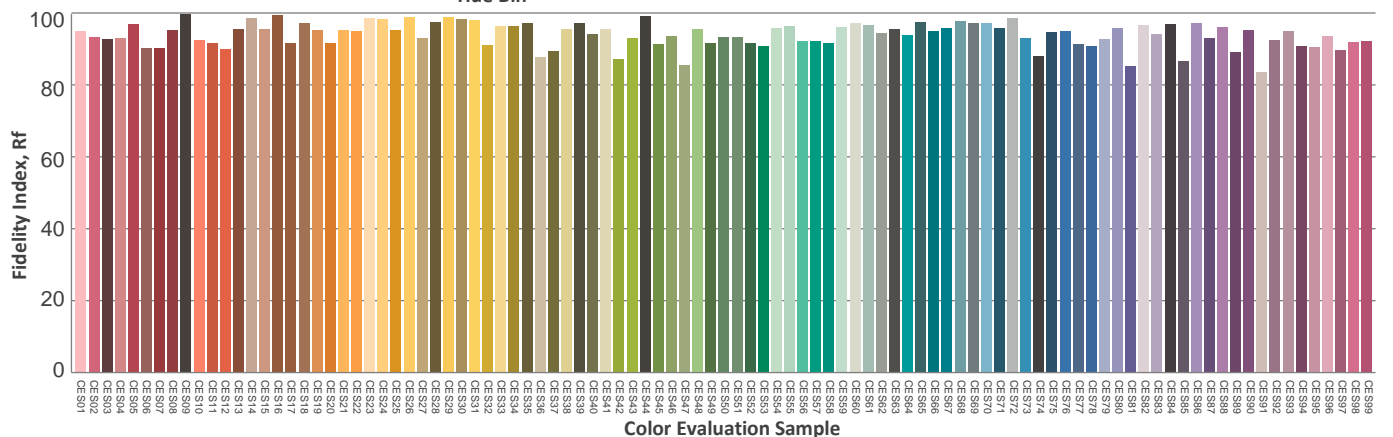
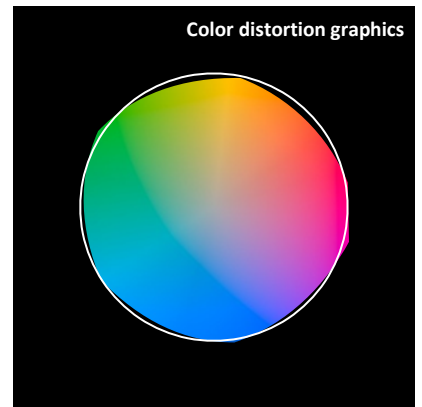
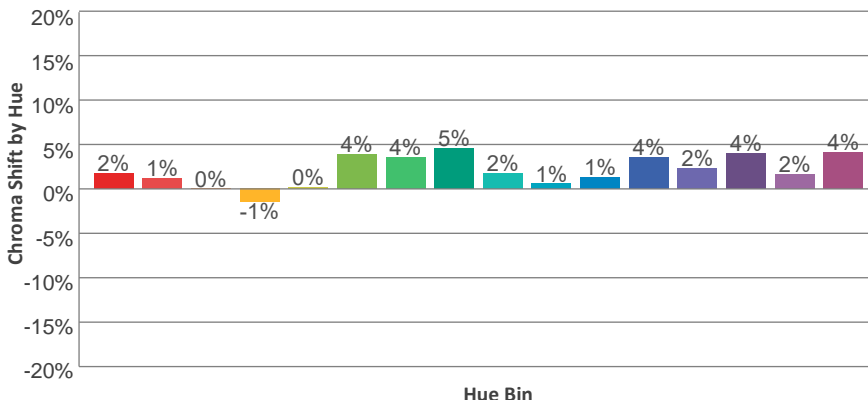
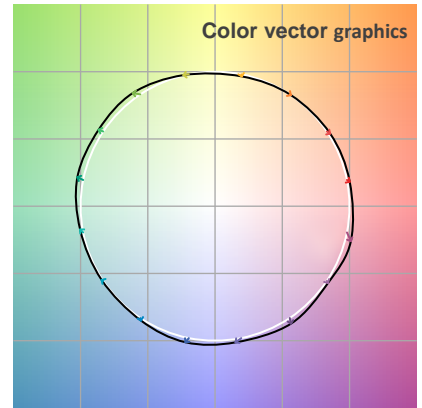
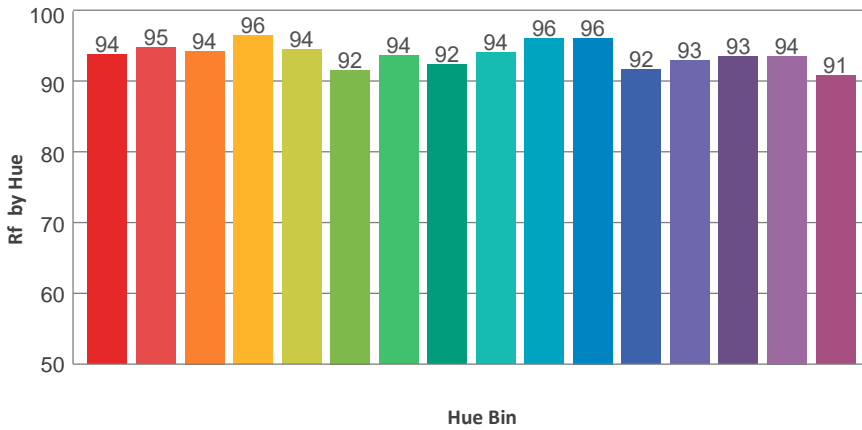
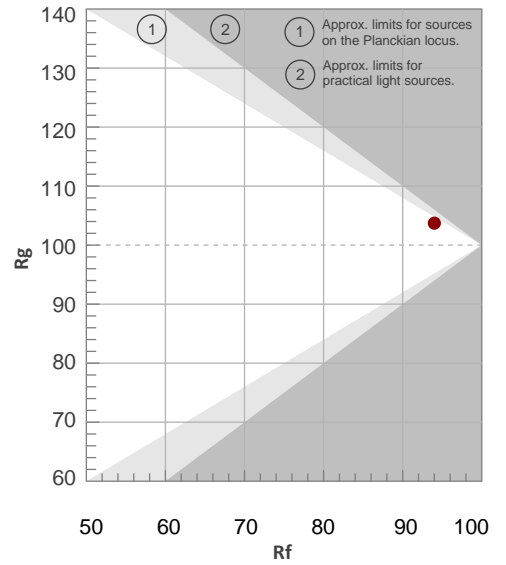

ISO Diagrams

ISO Candela Diagram

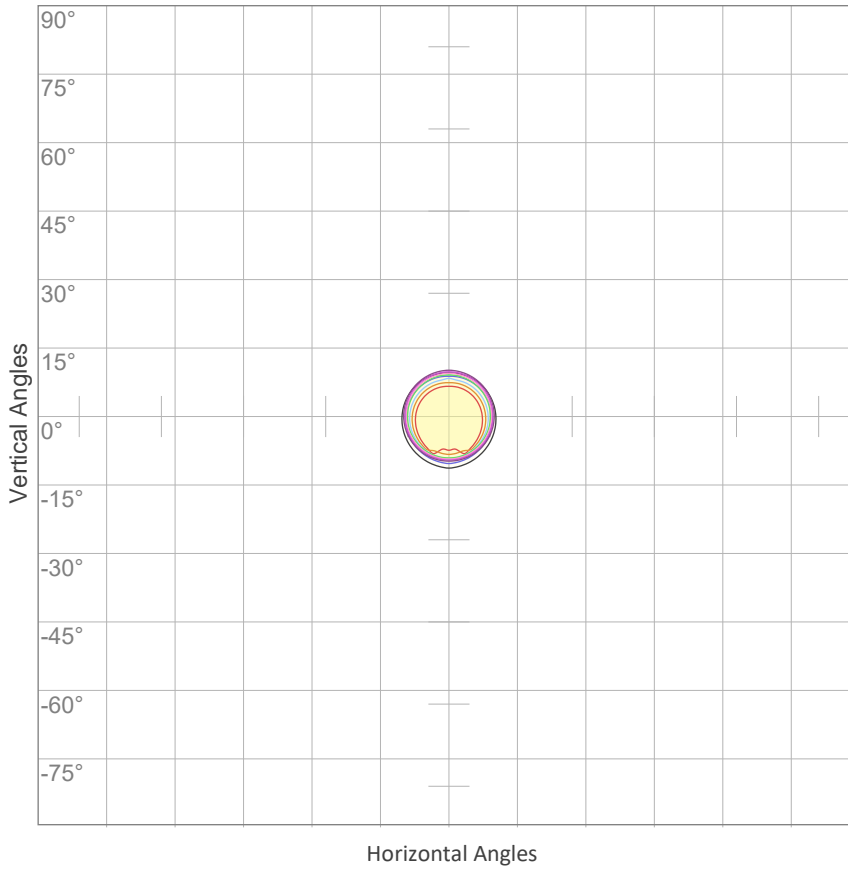

10%	8848 cd
20%	17696 cd
30%	26544 cd
40%	35392 cd
50%	44240 cd
60%	53088 cd
70%	61936 cd
80%	70783 cd
90%	79631 cd

Conditions:
 Number of c-planes: 2
 Candela at center: 88479 cd

ISO Lux Diagram

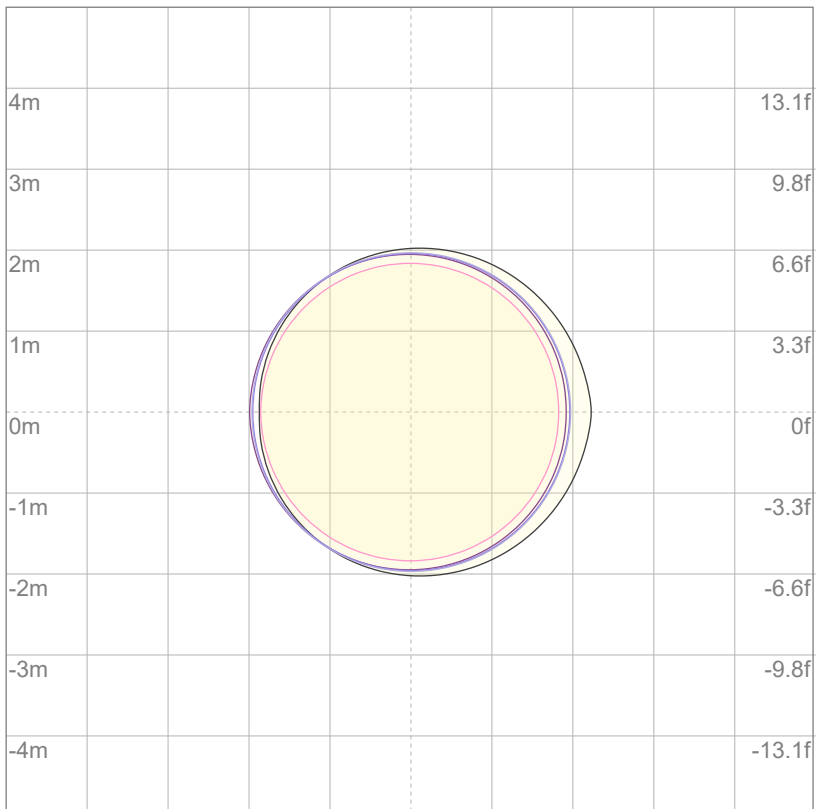

3%	26.5 lx
5%	44.2 lx
10%	88.5 lx
30%	265 lx
50%	442 lx

Conditions:
 Number of c-planes: 2
 Lux at center: 885 lx

Lux distribution on a surface when lamp is mounted at 10 meters from the surface.

Mounting Height: 10 meters (33 feet)

Photometric Report

Total Lumen Output*

VISO Lab Spion 8699 lm

Beam Angle 50%	Field Angle 10%	Cutoff Angle 2.5%
19.4°	22.5°	23.6°

Color Temperature: 3202 K

CRI: 92.8

TLCI: 92

TM30: 93.7

CQS: 93.7

Voltage: 121 V, Current: 4.20 A

Power: 507 W

Efficacy: 17 Lumen/Watt

Measurement Date: 3/18/2022

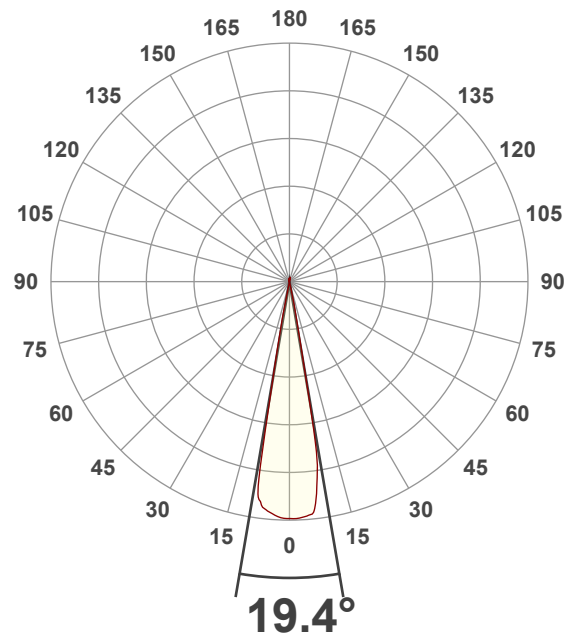

Spectral Distribution

Dominant Wavelength 582 nm

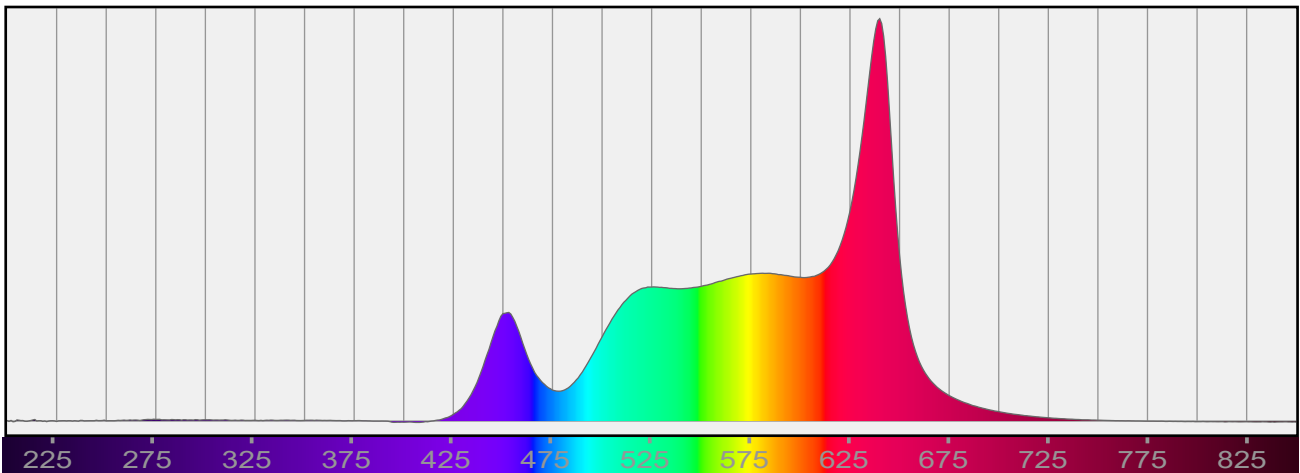

*Total Lumen measurements by calibrated Everfine 2π Integrating Sphere and Viso Systems Lab Spion

Beam Details

Beam Angle 50%	Field Angle 10%	Cutoff Angle 2,5%
19.4°	22.5°	23.6°

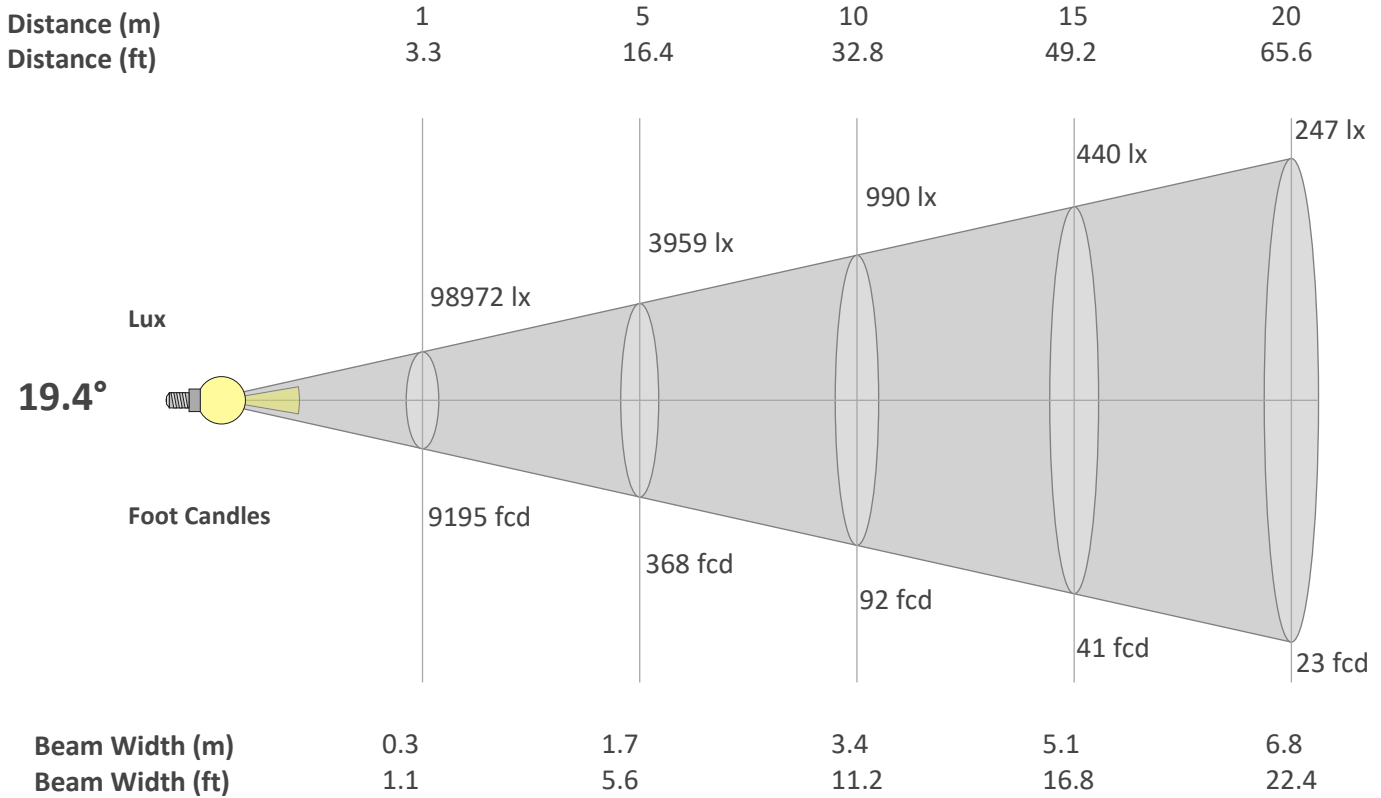

Beam Intensities from 1-20m

M	1	2	3	4	5	6	7	8	9	10	11	12	13	14	15	16	17	18	19	20
FT	3.3	6.6	9.8	13.1	16.4	19.7	23	26.2	29.5	32.8	36.1	39.4	42.7	45.9	49.2	52.5	55.8	59.1	62.3	65.6
LX	98972	24743	10997	6186	3959	2749	2020	1546	1222	990	818	687	586	505	440	387	342	305	274	247
FC	9194.8	2298.7	1021.6	574.7	367.8	255.4	187.6	143.7	113.5	91.9	76	63.9	54.4	46.9	40.9	35.9	31.8	28.4	25.5	23

Linear Distribution

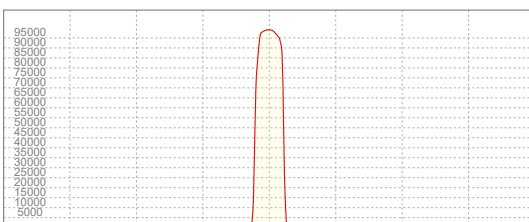

Peak Candela
99041 cd

Calculate Center Beam Intensities

$lux = 99041 / distance(m)^2$

$fc = 99041 / distance(ft)^2$

Color Details

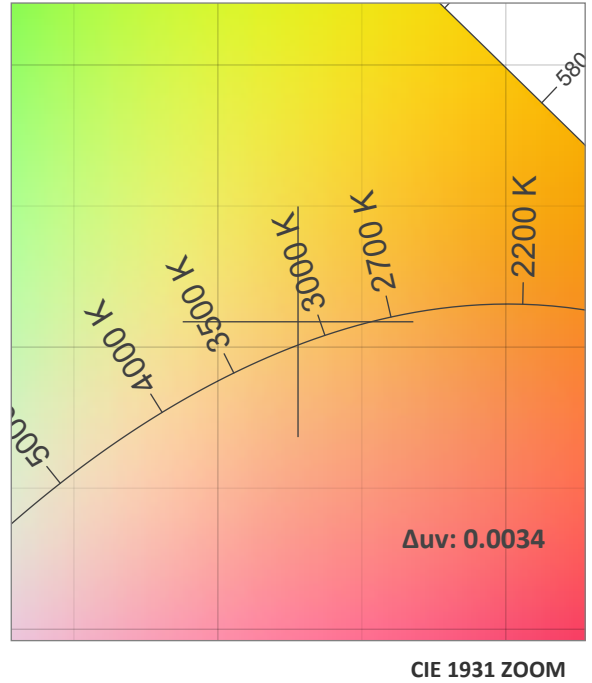
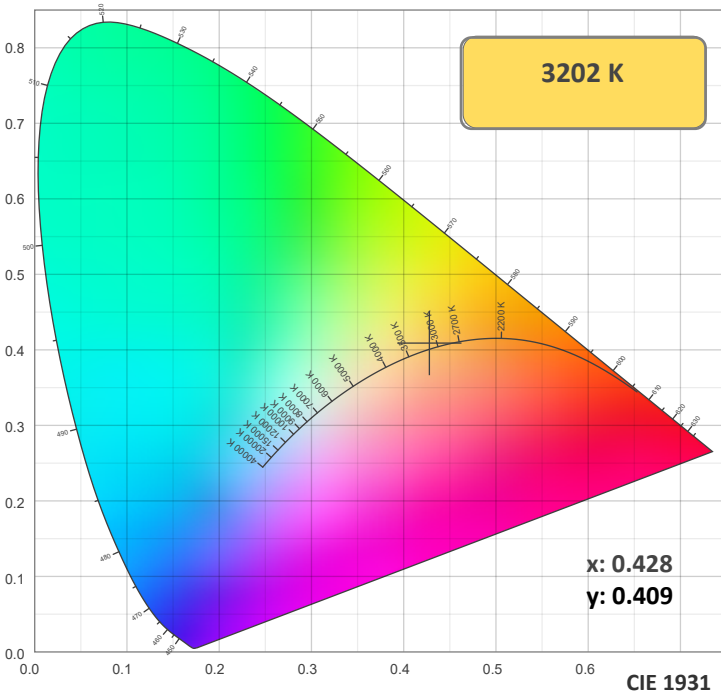

TM30: 93.7

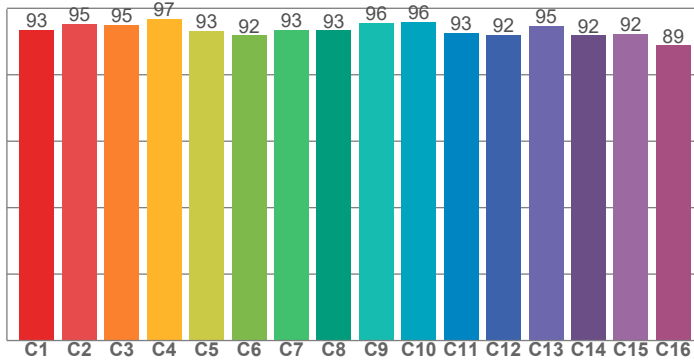

CRI: 92.8 (R1-R8)

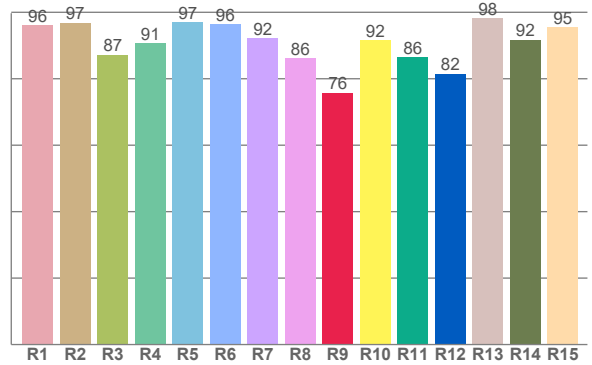

CRI R values, only R1-R8 are used to calculate final CRI value

R1	R2	R3	R4	R5	R6	R7	R8	R9	R10	R11	R12	R13	R14	R15
96.1	96.9	87.3	90.6	97.0	96.4	92.3	86.2	75.8	91.7	86.5	81.5	98.3	91.7	95.5

TM30 C Values, 16 binned values out of total of 99 C values

C1	C2	C3	C4	C5	C6	C7	C8	C9	C10	C11	C12	C13	C14	C15	C16
93.4	95.2	95.0	96.9	93.2	91.8	93.4	93.4	95.6	95.9	92.6	92.0	94.8	91.8	92.3	88.8

CQS Q Values

Q1	Q2	Q3	Q4	Q5	Q6	Q7	Q8	Q9	Q10	Q11	Q12	Q13	Q14	Q15
95.8	96.9	91.8	96.9	93.3	89.7	94.0	95.9	94.1	95.0	92.2	92.0	91.8	96.0	97.3

CQS: 93.7

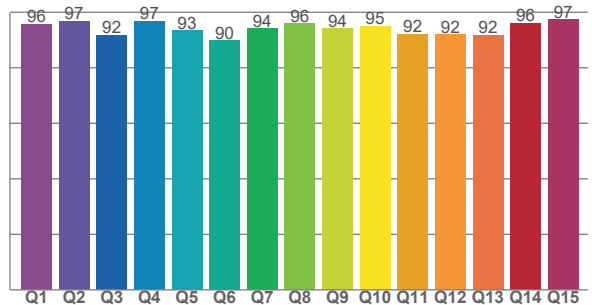

Color Parameters

Color Temperature	Color Rendering Index	Red Component	Color Fidelity	Color Gamut	Color Quality Scale	Color Coordinate CIE 1931	Color Coordinate CIE 1931	Color Coordinate	Color Coordinate	Color Diviation from Black
CCT	CRI	CRI R9	TM30 Rf	TM30 Rg	CQS	x	y	u	v	Δuv
3202 K	92.8	75.8	93.7	104.2	93.7	0.428	0.409	0.243	0.348	0.0034

TM30 Details

Rf 93.7
Fidelity Index Rf

Rg 104.2
Gamut Index Rg

Hue Bin	R _f	Graphic shifts (%)	
		Chroma	Hue
1	93	2%	-2%
2	95	1%	-2%
3	95	0%	0%
4	97	-1%	0%
5	93	-1%	3%
6	92	4%	3%
7	93	3%	1%
8	93	4%	-2%
9	96	1%	-1%
10	96	-1%	1%
11	93	1%	5%
12	92	5%	0%
13	95	3%	-2%
14	92	6%	0%
15	92	3%	-1%
16	89	6%	-7%

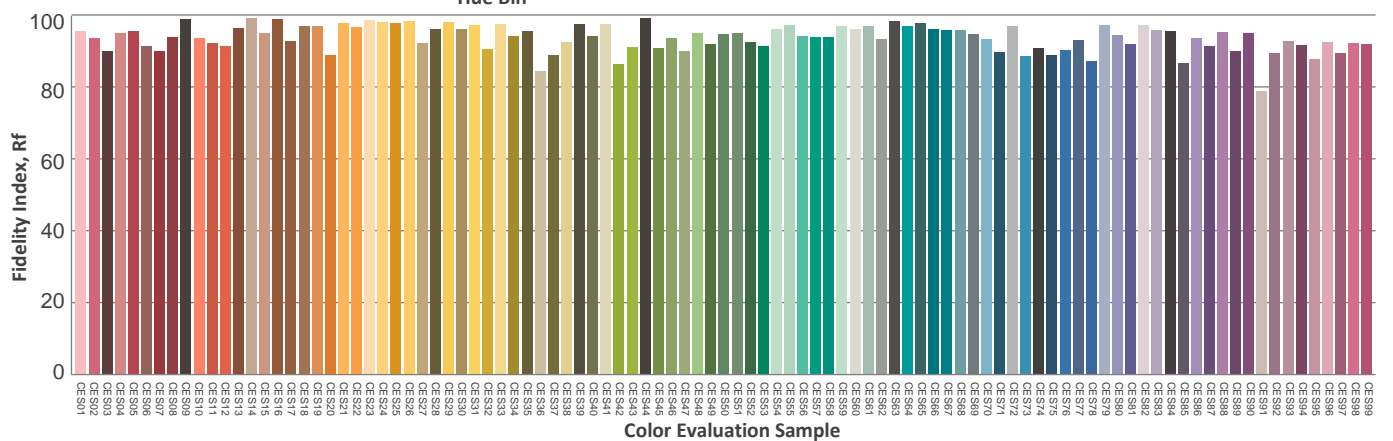
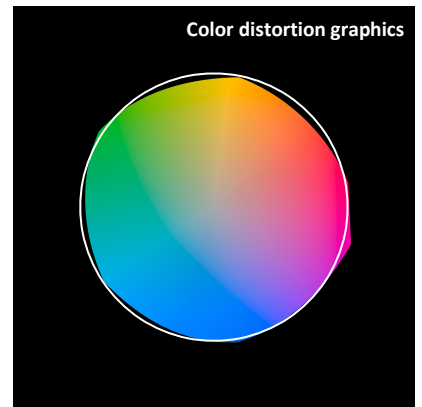
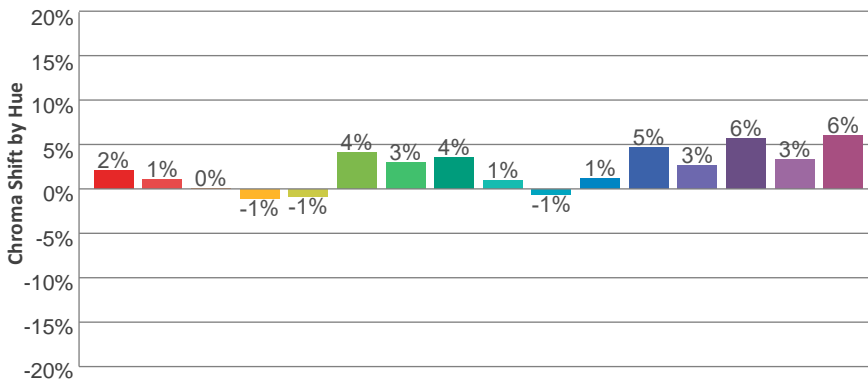
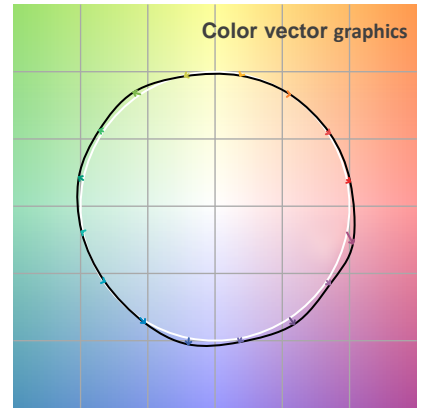
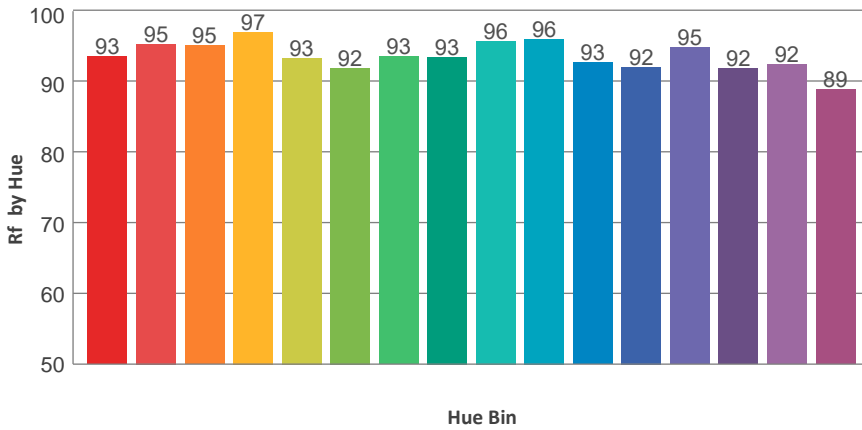
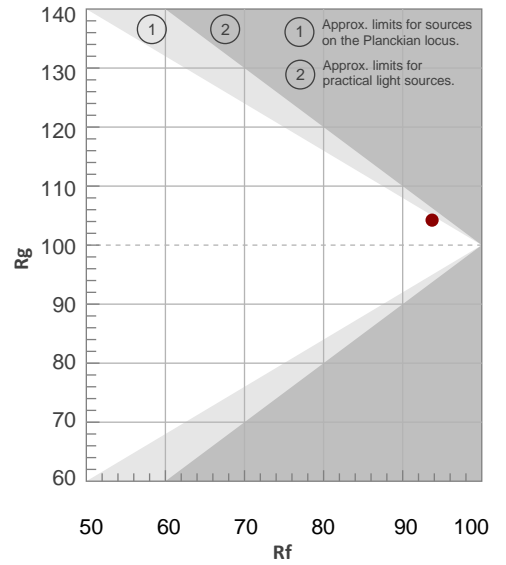

ISO Diagrams

ISO Candela Diagram

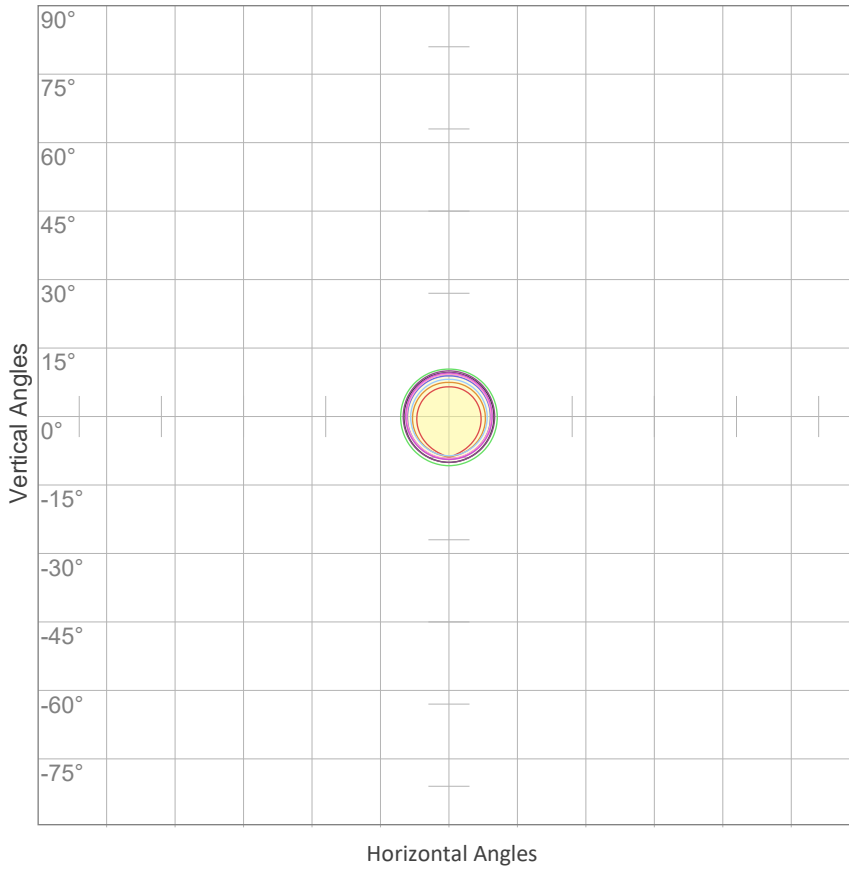

10%	9897 cd
20%	19794 cd
30%	29691 cd
40%	39589 cd
50%	49486 cd
60%	59383 cd
70%	69280 cd
80%	79177 cd
90%	89074 cd

Conditions:

Number of c-planes: 2

Candela at center: 98972 cd

ISO Lux Diagram

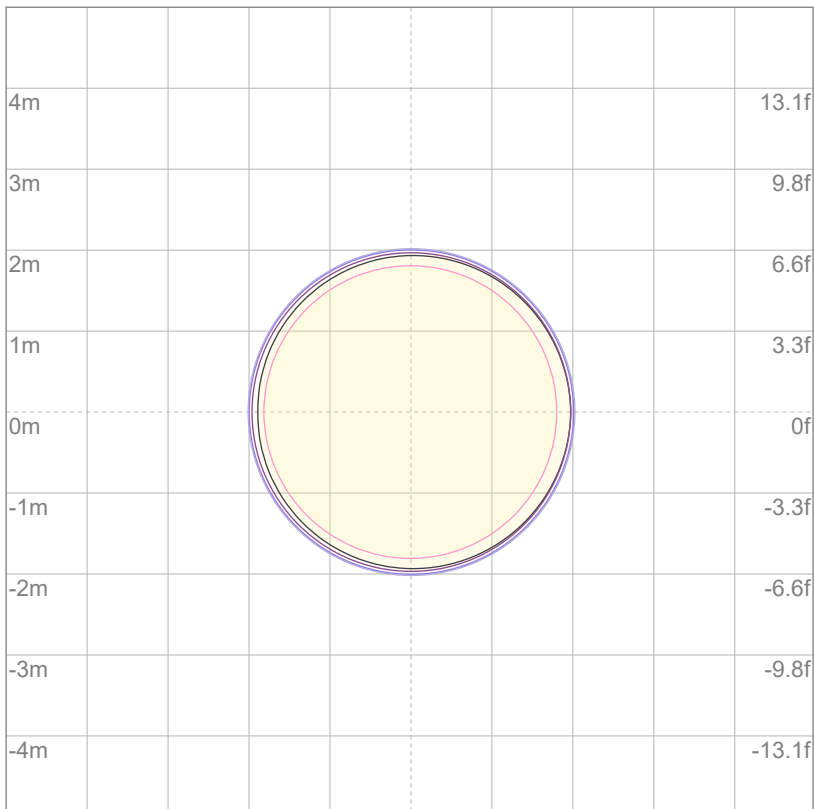

3%	29.7 lx
5%	49.5 lx
10%	99.0 lx
30%	297 lx
50%	495 lx

Conditions:

Number of c-planes: 2

Lux at center: 990 lx

Lux distribution on a surface when lamp is mounted at 10 meters from the surface.

Mounting Height: 10 meters (33 feet)

Photometric Report

Total Lumen Output*

VISO Lab Spion 11828 lm

Beam Angle 50%	Field Angle 10%	Cutoff Angle 2.5%
19.4°	23°	23.7°

Color Temperature: 4493 K

CRI: 92.8

TLCI: 93

TM30: 91.5

CQS: 93.5

Voltage: 121 V, Current: 5.22 A

Power: 629 W

Efficacy: 19 Lumen/Watt

Measurement Date: 3/18/2022

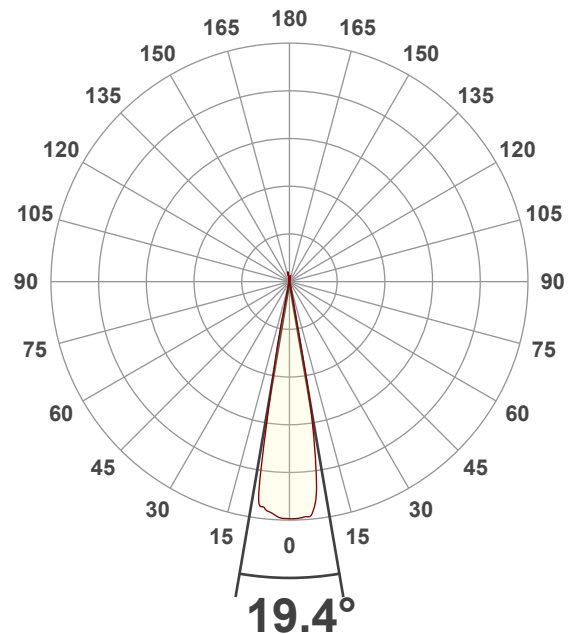

Spectral Distribution

Dominant Wavelength 579 nm

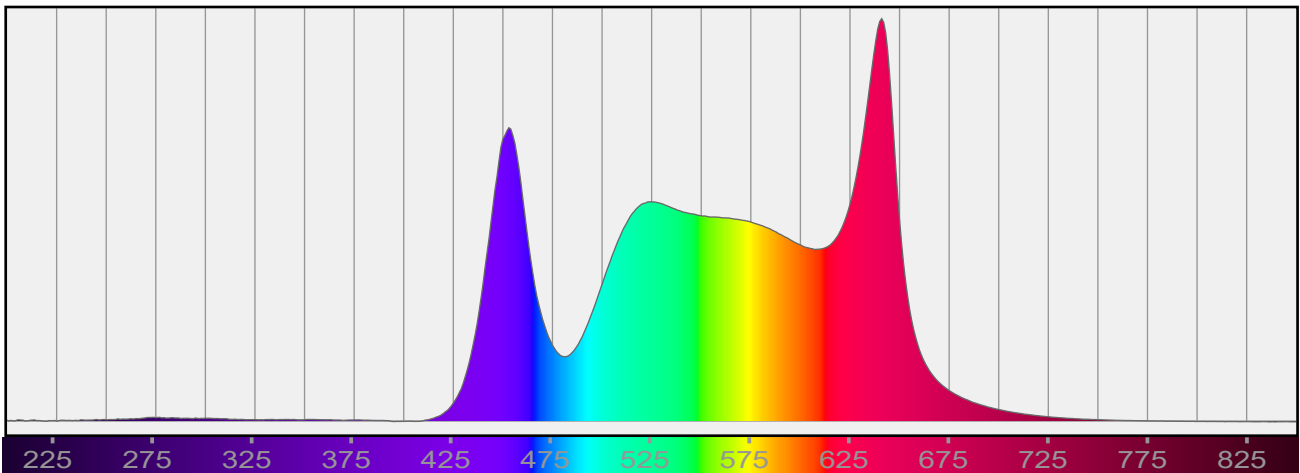

*Total Lumen measurements by calibrated Everfine 2π Integrating Sphere and Viso Systems Lab Spion

Beam Details

Beam Angle 50%	Field Angle 10%	Cutoff Angle 2,5%
19.4°	23°	23.7°

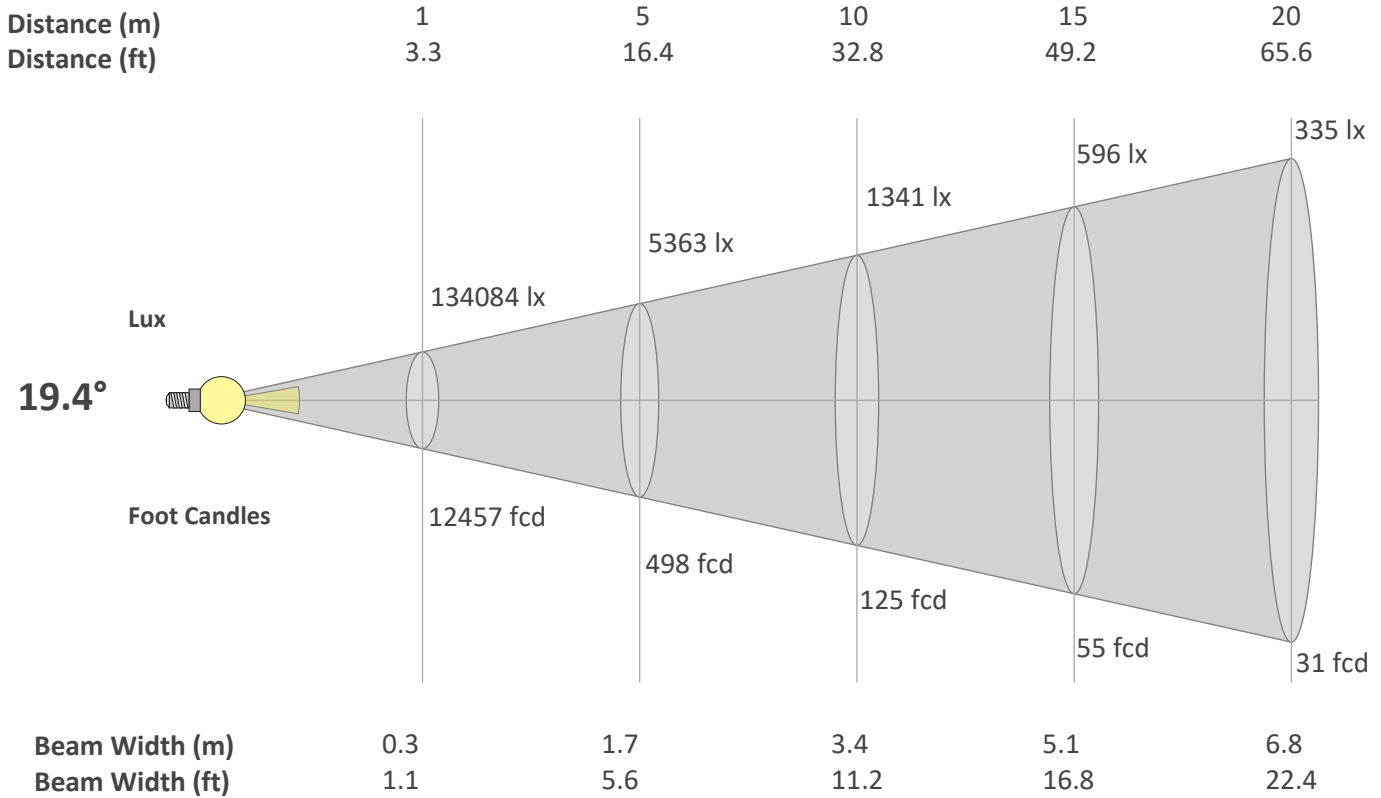

Beam Intensities from 1-20m

M	1	2	3	4	5	6	7	8	9	10	11	12	13	14	15	16	17	18	19	20
FT	3.3	6.6	9.8	13.1	16.4	19.7	23	26.2	29.5	32.8	36.1	39.4	42.7	45.9	49.2	52.5	55.8	59.1	62.3	65.6
LX	134084	33521	14898	8380	5363	3725	2736	2095	1655	1341	1108	931	793	684	596	524	464	414	371	335
FC	12456.8	3114.2	1384.1	778.6	498.3	346	254.2	194.6	153.8	124.6	102.9	86.5	73.7	63.6	55.4	48.7	43.1	38.4	34.5	31.1

Linear Distribution

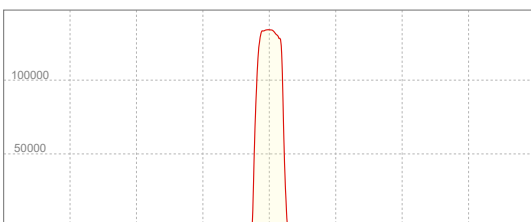

Peak Candela

134099 cd

Calculate Center Beam Intensities

$lux = 134099 / distance(m)^2$

$fc = 134099 / distance(ft)^2$

Color Details

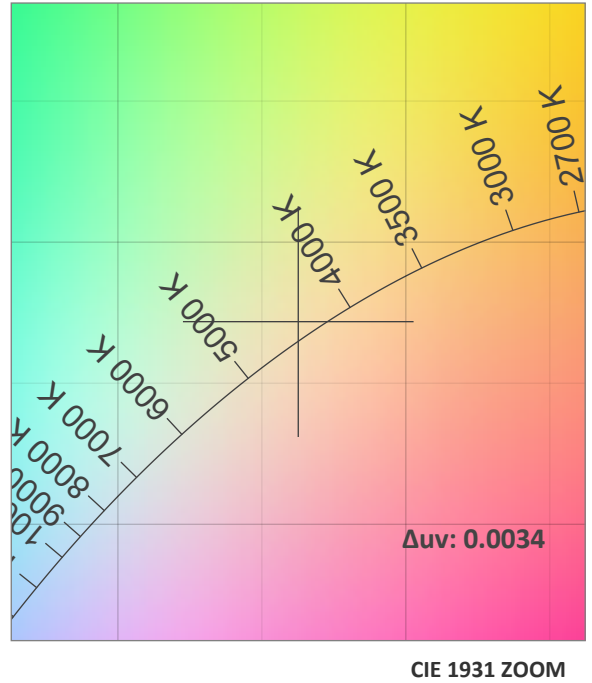
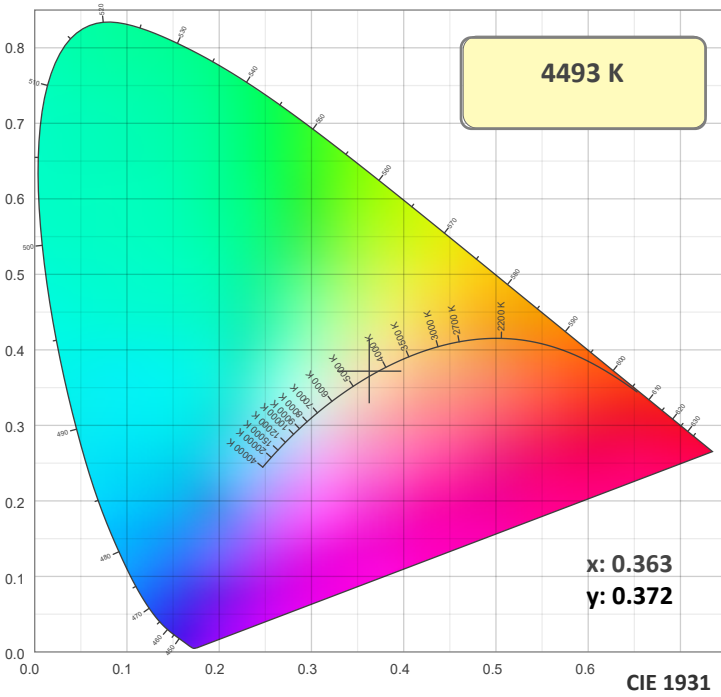

TM30: 91.5

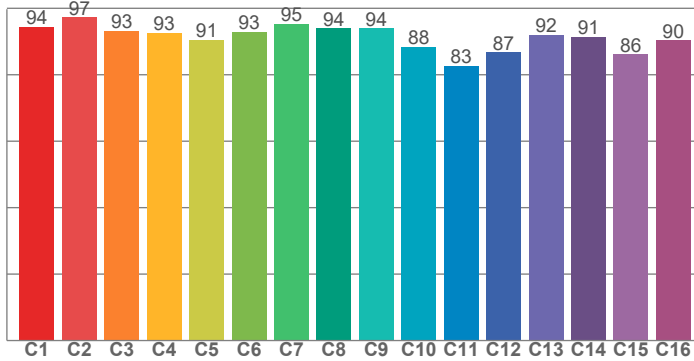

CRI: 92.8 (R1-R8)

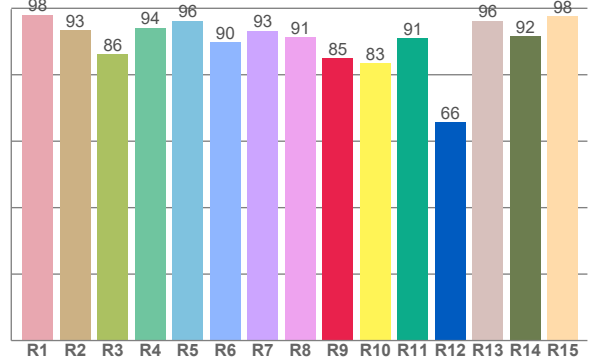

CRI R values, only R1-R8 are used to calculate final CRI value

R1	R2	R3	R4	R5	R6	R7	R8	R9	R10	R11	R12	R13	R14	R15
98.1	93.4	86.1	94.2	96.2	89.8	93.3	91.3	84.9	83.4	91.1	65.6	96.3	91.7	97.6

TM30 C Values, 16 binned values out of total of 99 C values

C1	C2	C3	C4	C5	C6	C7	C8	C9	C10	C11	C12	C13	C14	C15	C16
94.3	97.3	93.2	92.7	90.6	92.9	95.4	94.0	94.0	88.4	82.7	86.7	92.0	91.5	86.1	90.3

CQS Q Values

Q1	Q2	Q3	Q4	Q5	Q6	Q7	Q8	Q9	Q10	Q11	Q12	Q13	Q14	Q15
96.9	98.8	84.5	87.9	94.4	93.5	92.6	98.5	93.9	94.1	96.4	96.9	95.9	98.5	99.0

CQS: 93.5

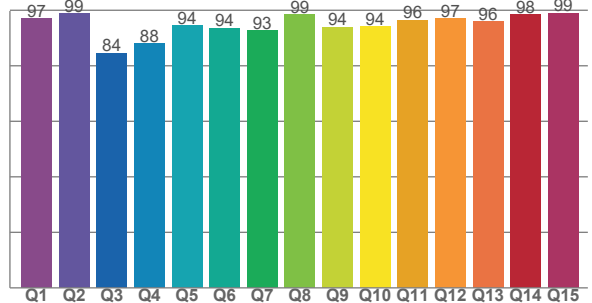

Color Parameters

Color Temperature	Color Rendering Index	Red Component	Color Fidelity	Color Gamut	Color Quality Scale	Color Coordinate CIE 1931	Color Coordinate CIE 1931	Color Coordinate	Color Coordinate	Color Diviation from Black
CCT	CRI	CRI R9	TM30 Rf	TM30 Rg	CQS	x	y	u	v	Δuv
4493 K	92.8	84.9	91.5	103.6	93.5	0.363	0.372	0.215	0.331	0.0034

TM30 Details

Rf 91.5
Fidelity Index Rf

Rg 103.6
Gamut Index Rg

Hue Bin	R _f	Graphic shifts (%)	
		Chroma	Hue
1	94	1%	-1%
2	97	0%	-1%
3	93	0%	3%
4	93	-1%	3%
5	91	0%	4%
6	93	4%	2%
7	95	2%	-1%
8	94	0%	-1%
9	94	-3%	2%
10	88	-3%	6%
11	83	2%	11%
12	87	4%	7%
13	92	6%	3%
14	91	5%	2%
15	86	11%	-6%
16	90	3%	-4%

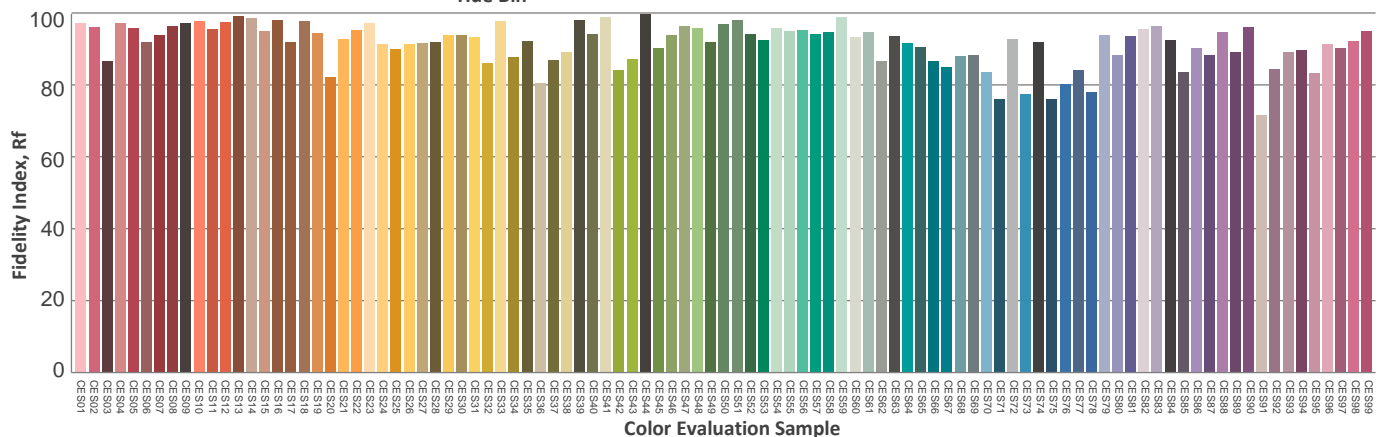
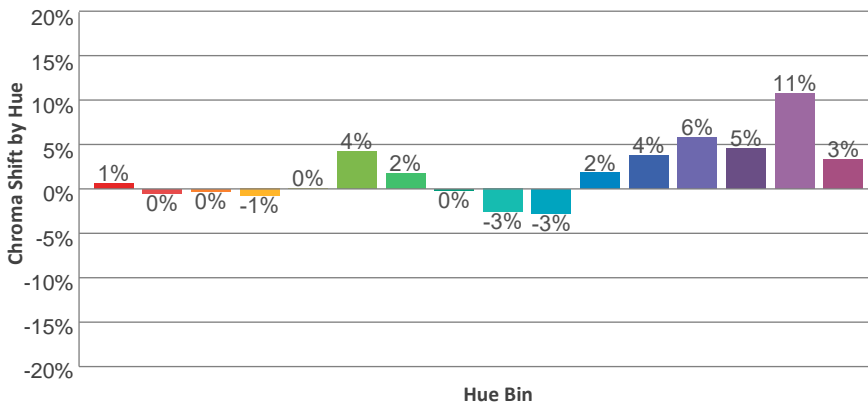
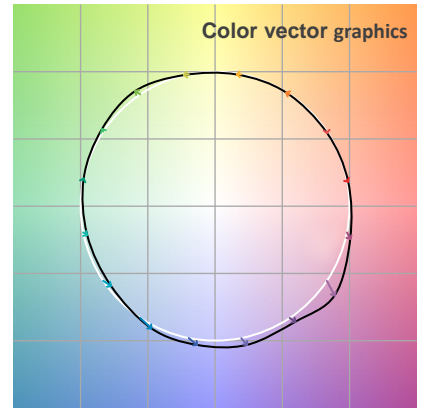
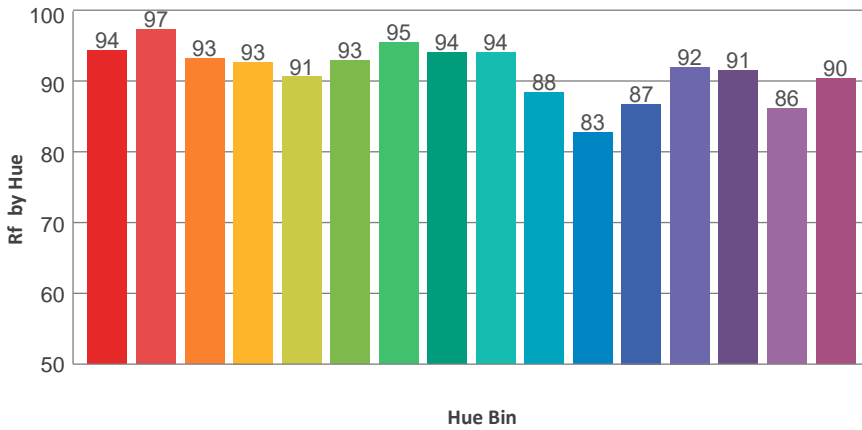
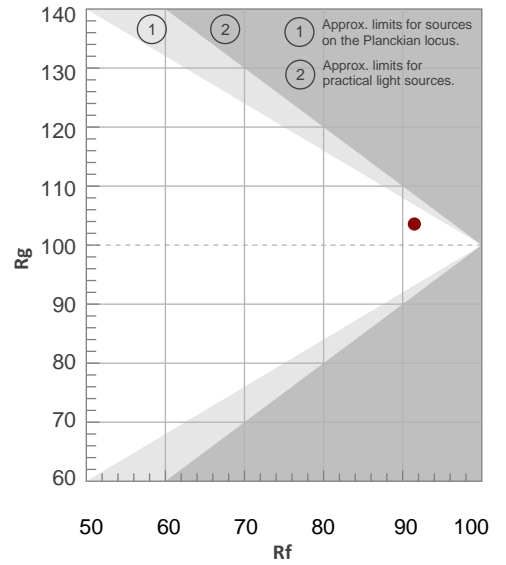

ISO Diagrams

ISO Candela Diagram

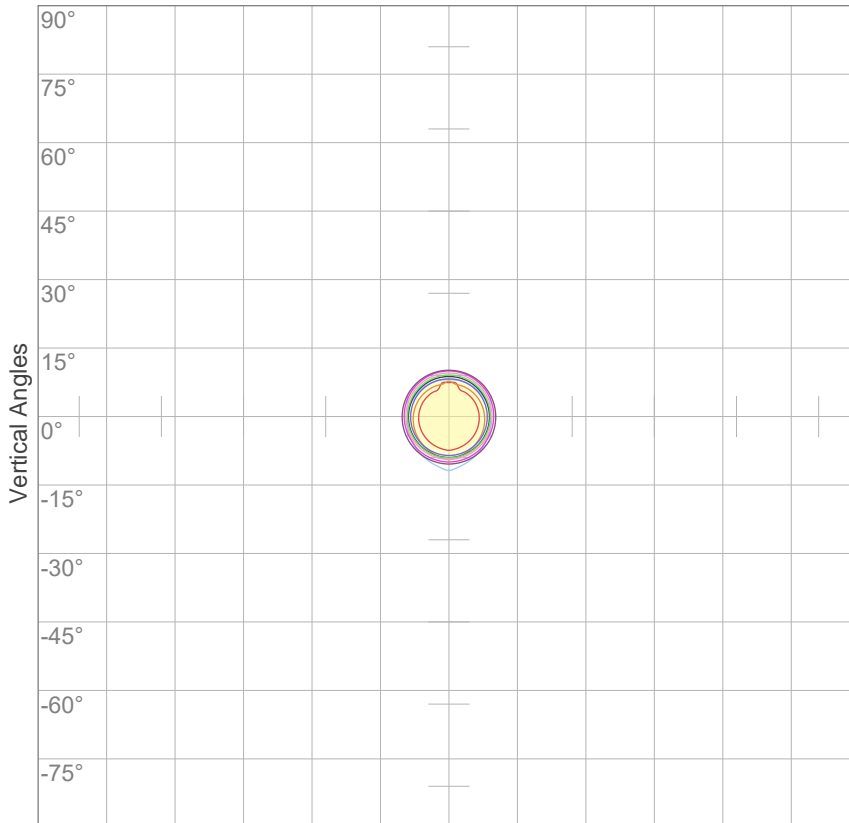

10%	13408 cd
20%	26817 cd
30%	40225 cd
40%	53634 cd
50%	67042 cd
60%	80450 cd
70%	93859 cd
80%	107267 cd
90%	120676 cd

Conditions:
 Number of c-planes: 2
 Candela at center: 134084 cd

ISO Lux Diagram

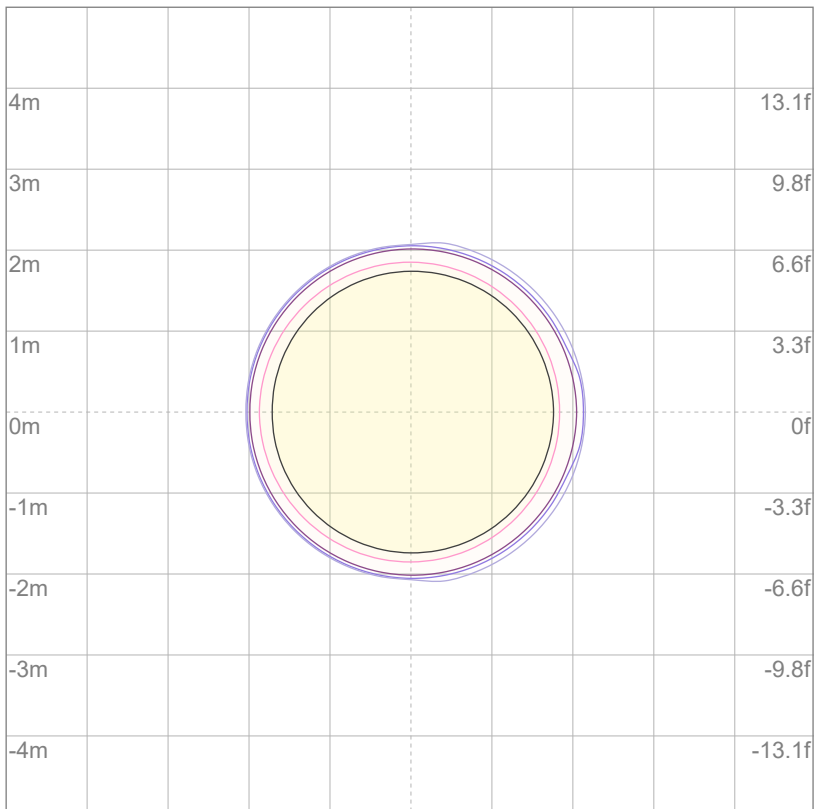

3%	40.2 lx
5%	67.0 lx
10%	134 lx
30%	402 lx
50%	670 lx

Conditions:
 Number of c-planes: 2
 Lux at center: 1341 lx

Lux distribution on a surface when lamp is mounted at 10 meters from the surface.

Mounting Height: 10 meters (33 feet)

Photometric Report

Total Lumen Output*

VISO Lab Spion 13255 lm

Beam Angle 50%	Field Angle 10%	Cutoff Angle 2.5%
19.4°	23°	23.7°

Color Temperature: 5628 K

CRI: 92.3

TLCI: 94

TM30: 90.6

CQS: 92.4

Voltage: 121 V, Current: 5.89 A

Power: 711 W

Efficacy: 19 Lumen/Watt

Measurement Date: 3/18/2022

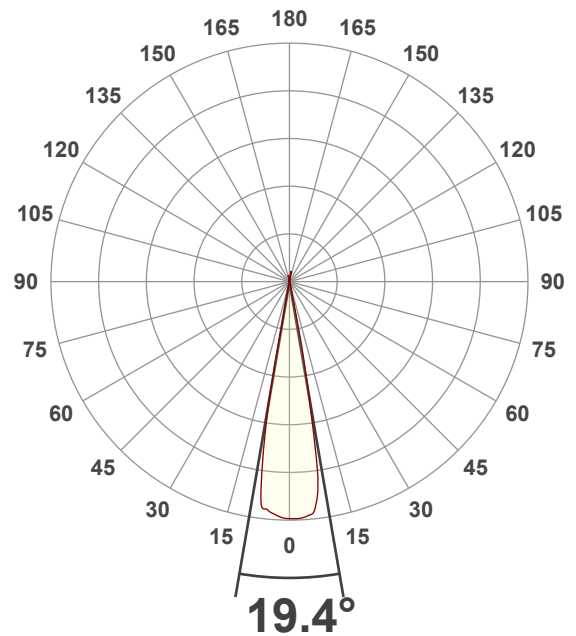

Spectral Distribution

Dominant Wavelength 577 nm

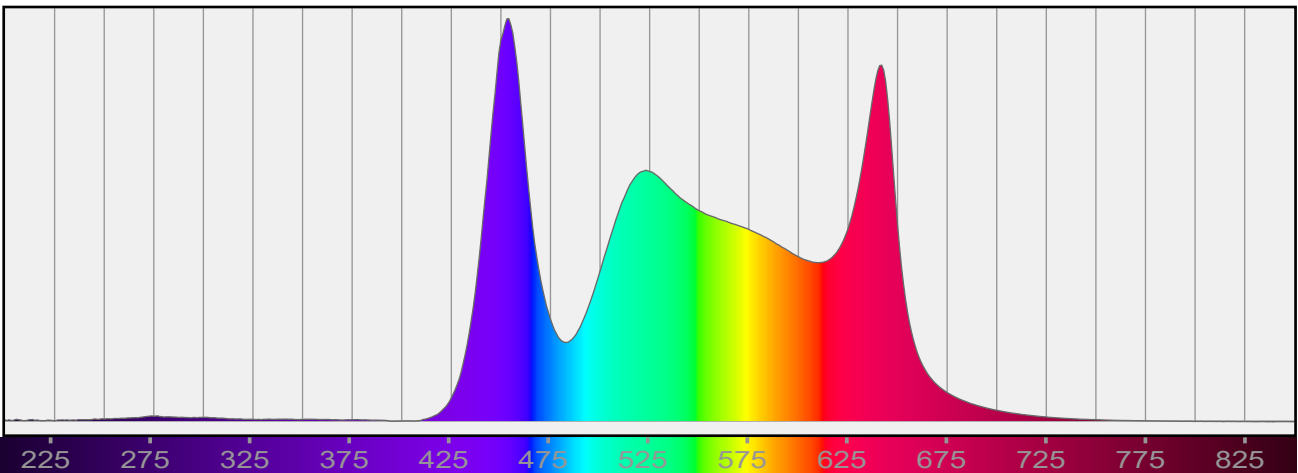

*Total Lumen measurements by calibrated Everfine 2π Integrating Sphere and Viso Systems Lab Spion

Beam Details

Beam Angle 50%	Field Angle 10%	Cutoff Angle 2,5%
19.4°	23°	23.7°

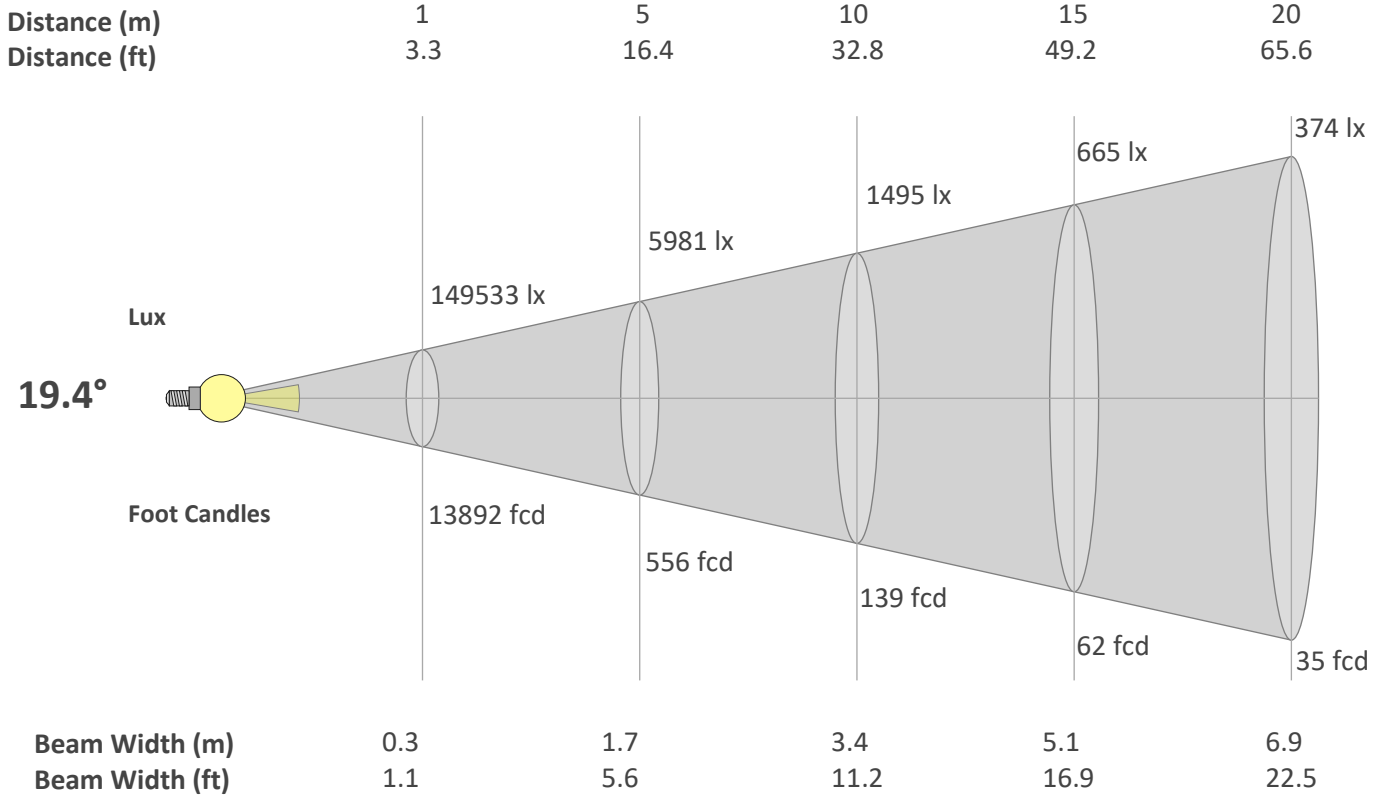

Beam Intensities from 1-20m

M	1	2	3	4	5	6	7	8	9	10	11	12	13	14	15	16	17	18	19	20
FT	3.3	6.6	9.8	13.1	16.4	19.7	23	26.2	29.5	32.8	36.1	39.4	42.7	45.9	49.2	52.5	55.8	59.1	62.3	65.6
LX	149533	37383	16615	9346	5981	4154	3052	2336	1846	1495	1236	1038	885	763	665	584	517	462	414	374
FC	13892.1	3473	1543.6	868.3	555.7	385.9	283.5	217.1	171.5	138.9	114.8	96.5	82.2	70.9	61.7	54.3	48.1	42.9	38.5	34.7

Linear Distribution

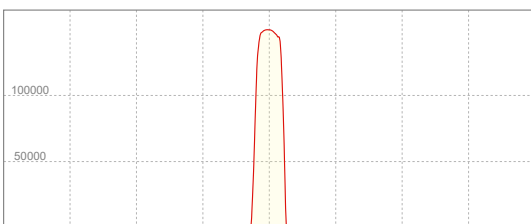

Peak Candela

149627 cd

Calculate Center Beam Intensities

lux = 149627 / distance(m)²

fc = 149627 / distance(ft)²

Color Details

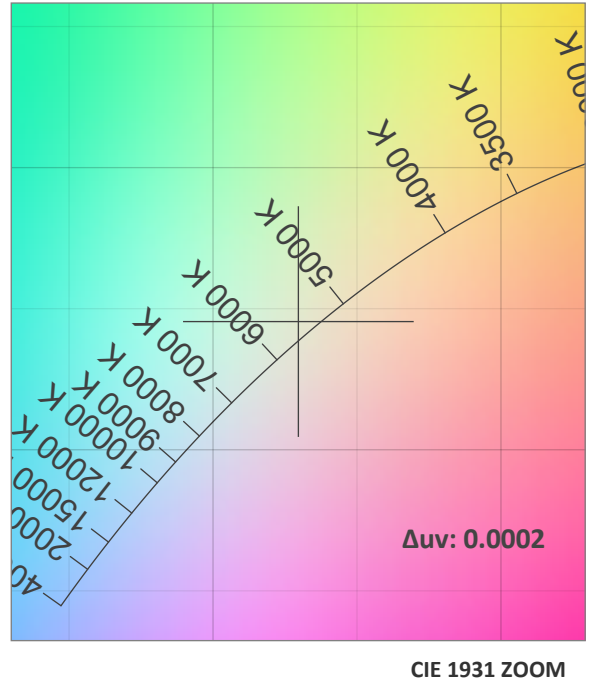
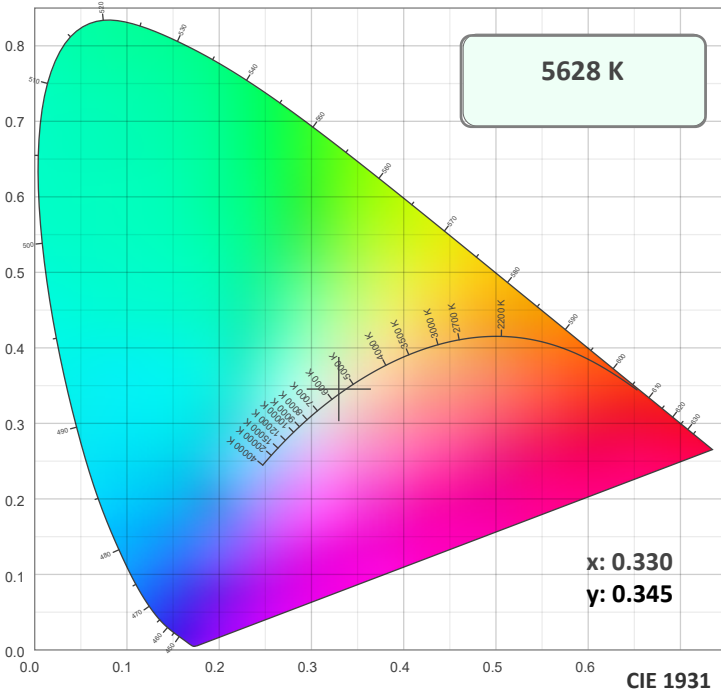

TM30: 90.6

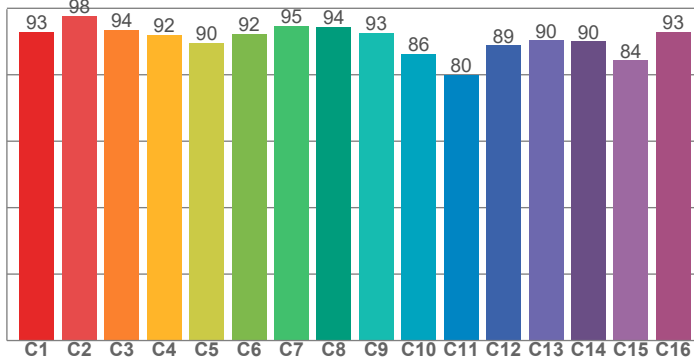

CRI: 92.3 (R1-R8)

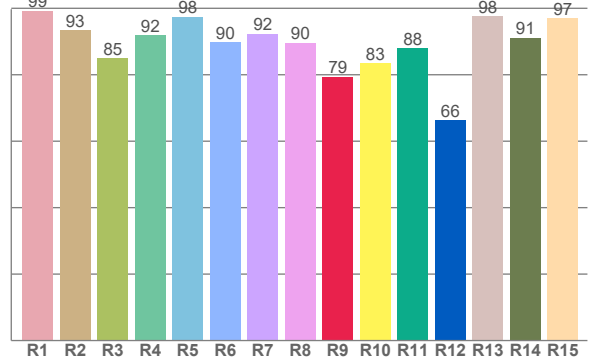

CRI R values, only R1-R8 are used to calculate final CRI value

R1	R2	R3	R4	R5	R6	R7	R8	R9	R10	R11	R12	R13	R14	R15
99.3	93.5	85.0	91.8	97.5	89.7	92.3	89.6	79.4	83.4	88.0	66.4	97.6	91.2	97.0

TM30 C Values, 16 binned values out of total of 99 C values

C1	C2	C3	C4	C5	C6	C7	C8	C9	C10	C11	C12	C13	C14	C15	C16
92.8	97.8	93.5	92.0	89.5	92.3	94.8	94.5	92.7	86.4	79.9	88.8	90.4	90.0	84.4	92.8

CQS Q Values

Q1	Q2	Q3	Q4	Q5	Q6	Q7	Q8	Q9	Q10	Q11	Q12	Q13	Q14	Q15
96.7	97.4	81.9	85.8	93.9	93.2	92.5	98.5	92.0	91.6	95.3	97.8	97.2	98.6	98.8

CQS: 92.4

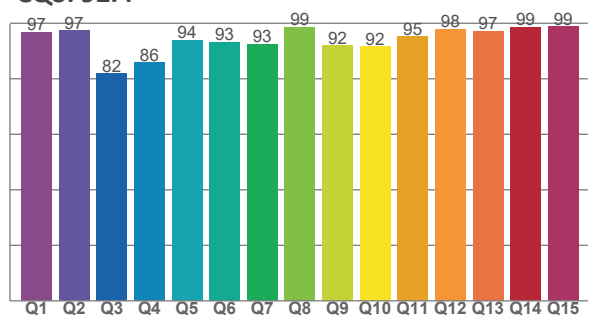

Color Parameters

Color Temperature	Color Rendering Index	Red Component	Color Fidelity	Color Gamut	Color Quality Scale	Color Coordinate CIE 1931	Color Coordinate CIE 1931	Color Coordinate	Color Coordinate	Color Diviation from Black
CCT	CRI	CRI R9	TM30 Rf	TM30 Rg	CQS	x	y	u	v	Δuv
5628 K	92.3	79.4	90.6	103.9	92.4	0.330	0.345	0.203	0.320	0.0002

TM30 Details

Rf 90.6
Fidelity Index Rf

Rg 103.9
Gamut Index Rg

Hue Bin	R _f	Graphic shifts (%)	
		Chroma	Hue
1	93	2%	-1%
2	98	0%	-1%
3	94	0%	2%
4	92	-1%	3%
5	90	0%	4%
6	92	4%	2%
7	95	2%	0%
8	94	-1%	0%
9	93	-3%	5%
10	86	-3%	8%
11	80	2%	13%
12	89	2%	7%
13	90	6%	6%
14	90	5%	2%
15	84	14%	-4%
16	93	3%	-2%

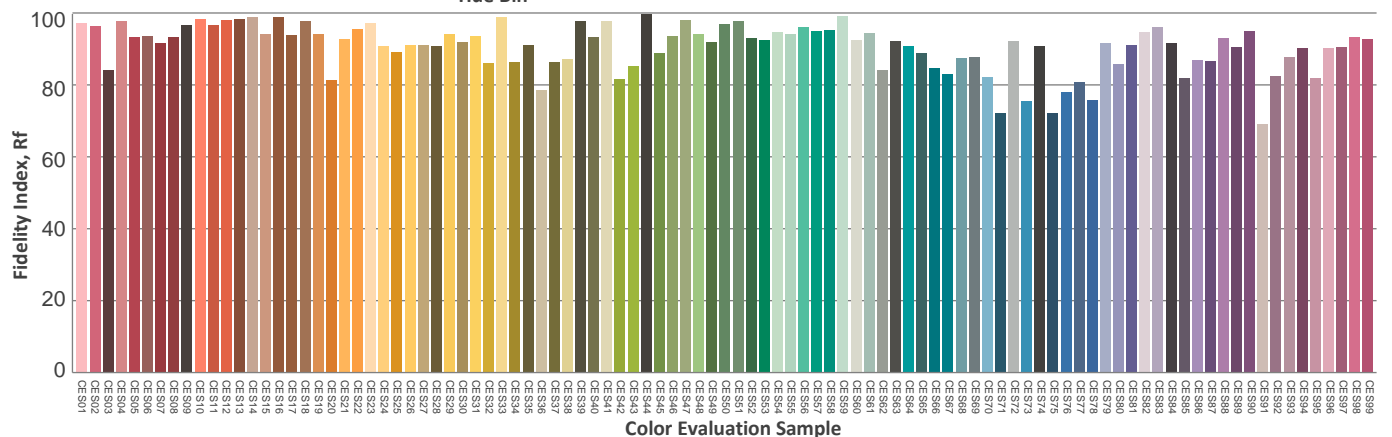
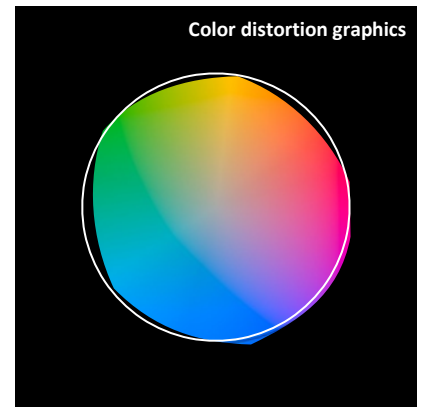
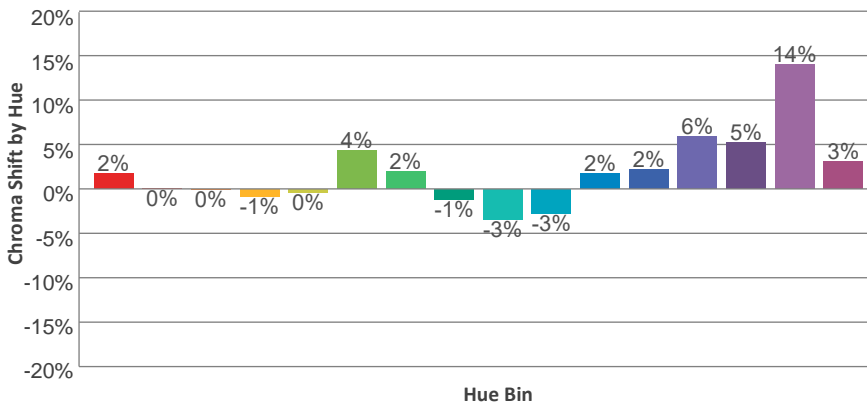
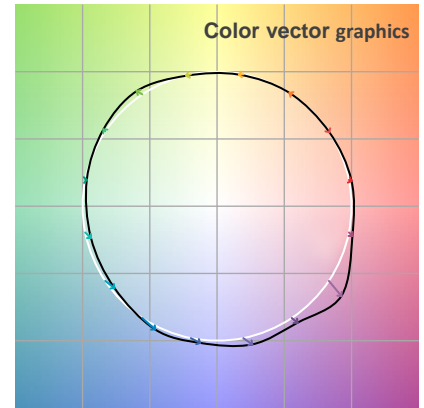
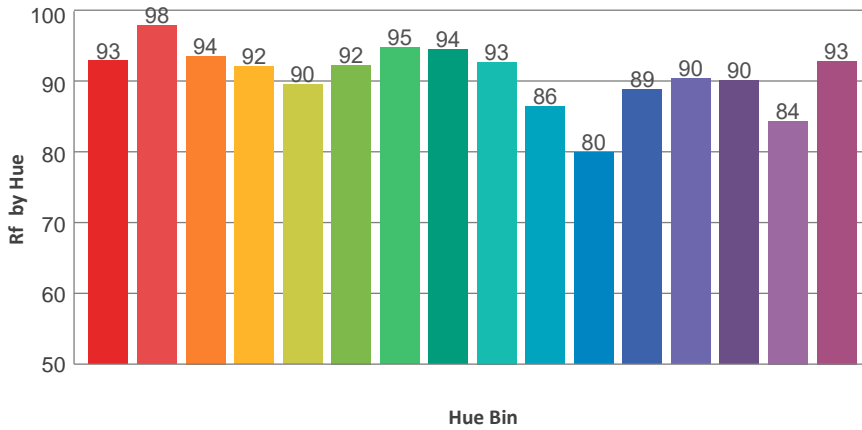
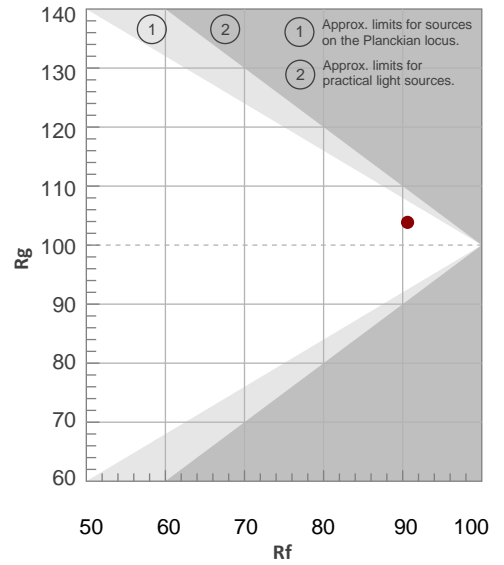

ISO Diagrams

ISO Candela Diagram

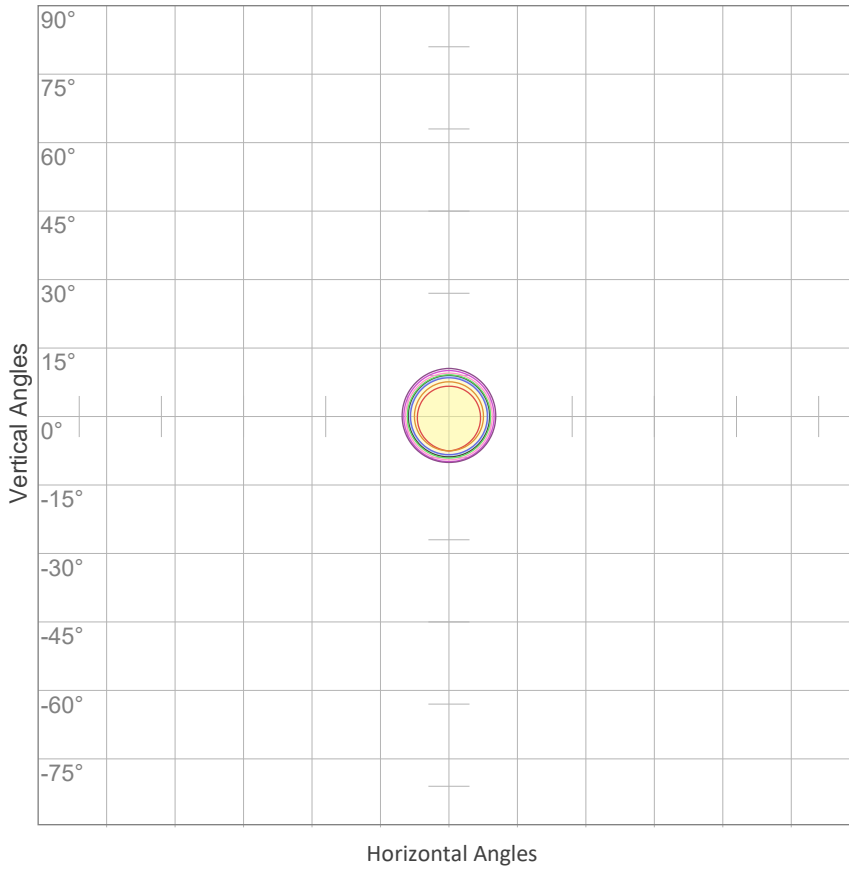

10%	14953 cd
20%	29907 cd
30%	44860 cd
40%	59813 cd
50%	74767 cd
60%	89720 cd
70%	104673 cd
80%	119627 cd
90%	134580 cd

Conditions:

Number of c-planes: 2

Candela at center: 149533 cd

ISO Lux Diagram

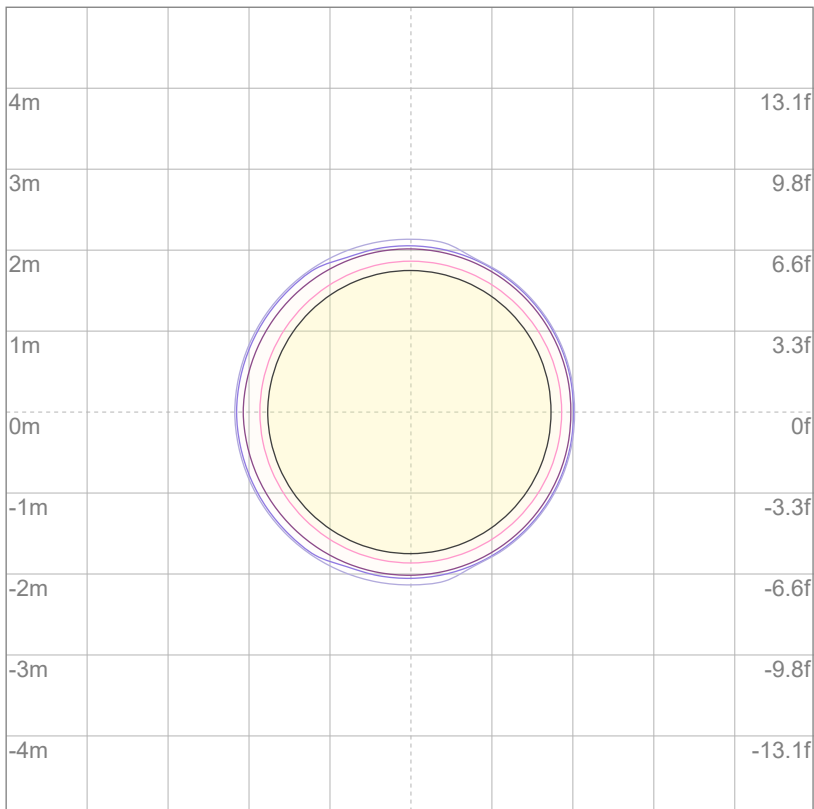

3%	44.9 lx
5%	74.8 lx
10%	150 lx
30%	449 lx
50%	748 lx

Conditions:

Number of c-planes: 2

Lux at center: 1495 lx

Lux distribution on a surface when lamp is mounted at 10 meters from the surface.

Mounting Height: 10 meters (33 feet)

Photometric Report

Total Lumen Output*

VISO Lab Spion 13021 lm

Beam Angle 50%	Field Angle 10%	Cutoff Angle 2.5%
19.4°	22.3°	23.6°

Color Temperature: 6000 K

CRI: 92.2

TLCI: 95

TM30: 90.4

CQS: 92.5

Voltage: 118 V, Current: 6.14 A

Power: 724 W

Efficacy: 18 Lumen/Watt

Measurement Date: 3/18/2022

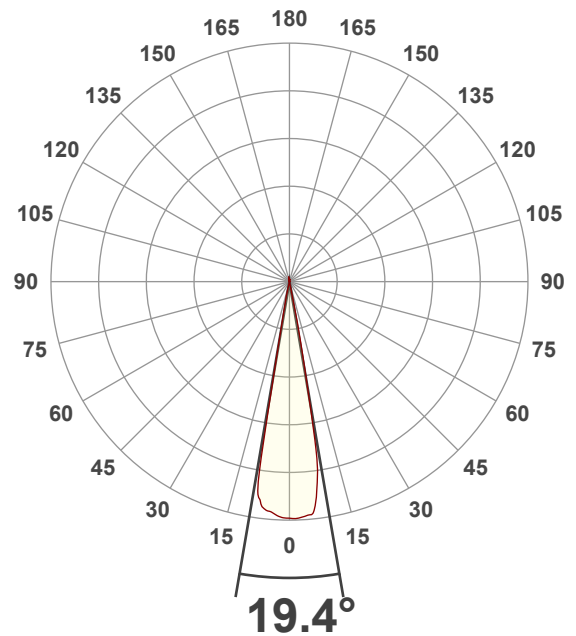

Spectral Distribution

Dominant Wavelength 576 nm

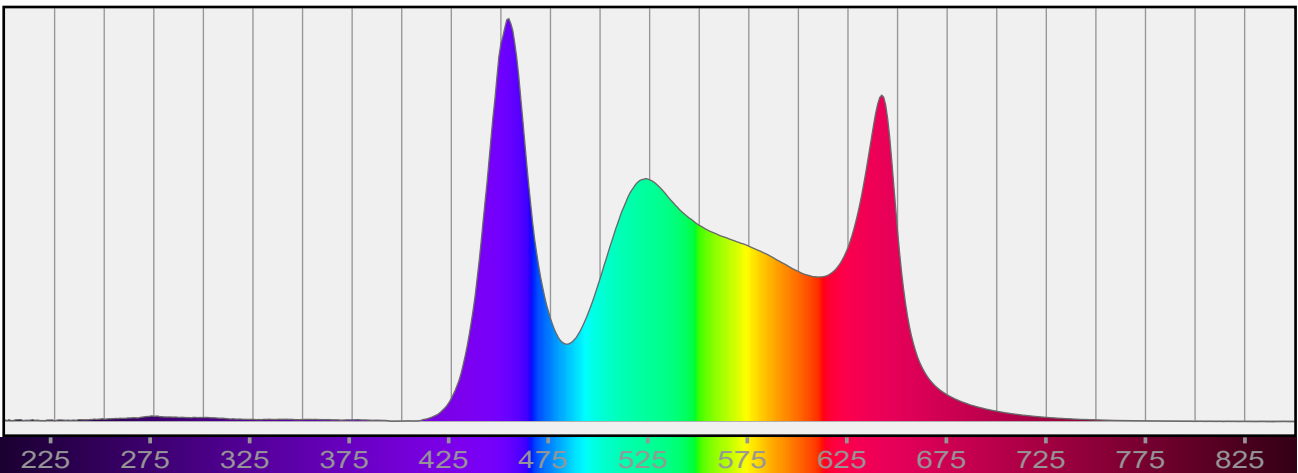

*Total Lumen measurements by calibrated Everfine 2π Integrating Sphere and Viso Systems Lab Spion

Beam Details

Beam Angle 50%	Field Angle 10%	Cutoff Angle 2,5%
19.4°	22.3°	23.6°

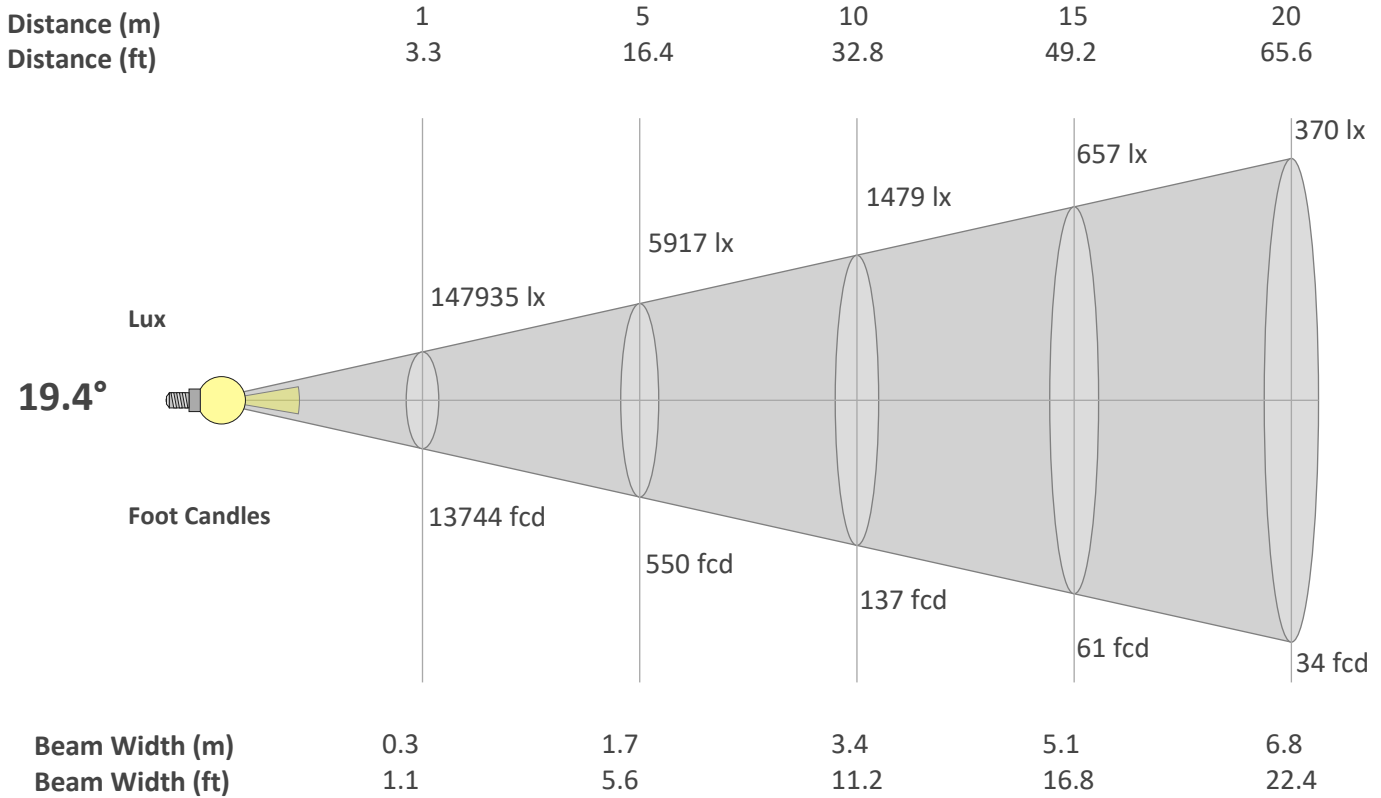

Beam Intensities from 1-20m

M	1	2	3	4	5	6	7	8	9	10	11	12	13	14	15	16	17	18	19	20
FT	3.3	6.6	9.8	13.1	16.4	19.7	23	26.2	29.5	32.8	36.1	39.4	42.7	45.9	49.2	52.5	55.8	59.1	62.3	65.6
LX	147935	36984	16437	9246	5917	4109	3019	2311	1826	1479	1223	1027	875	755	657	578	512	457	410	370
FC	13743.7	3435.9	1527.1	859	549.7	381.8	280.5	214.7	169.7	137.4	113.6	95.4	81.3	70.1	61.1	53.7	47.6	42.4	38.1	34.4

Linear Distribution

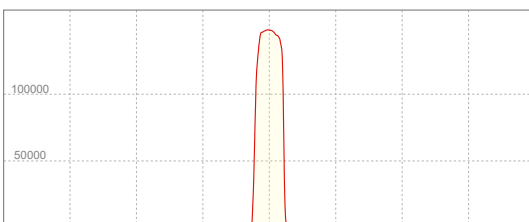

Peak Candela
148250 cd

Calculate Center Beam Intensities

$lux = 148250 / distance(m)^2$

$fc = 148250 / distance(ft)^2$

Color Details

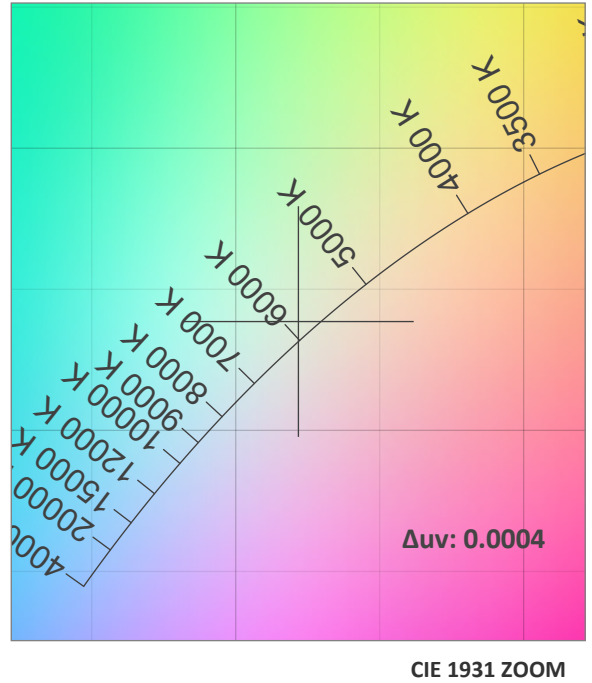
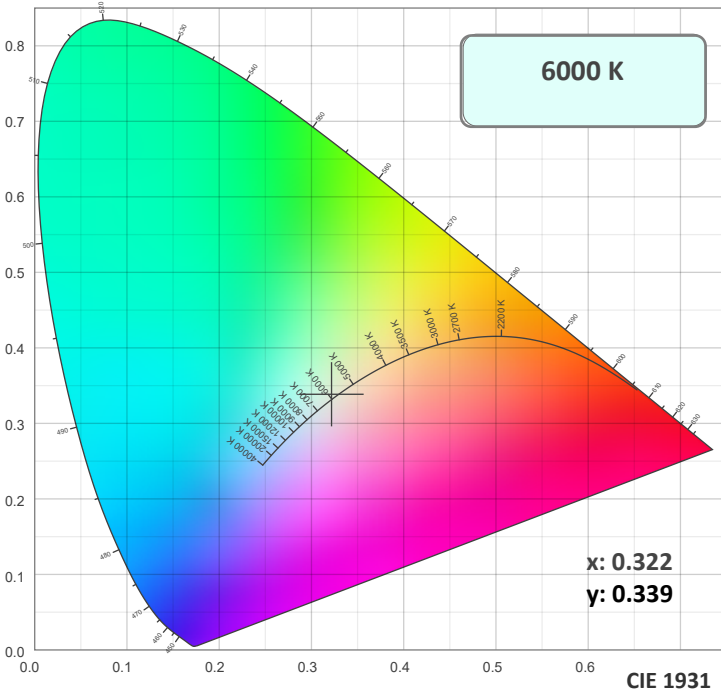

TM30: 90.4

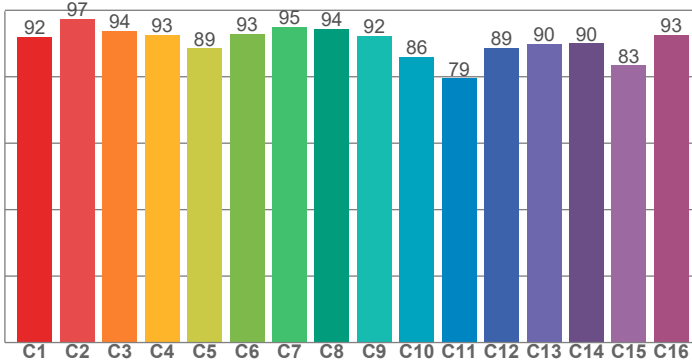

CRI: 92.2 (R1-R8)

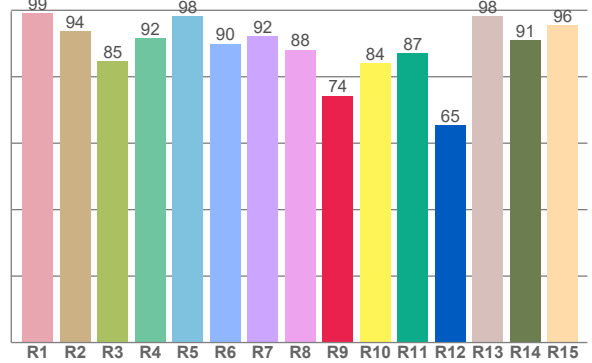

CRI R values, only R1-R8 are used to calculate final CRI value

R1	R2	R3	R4	R5	R6	R7	R8	R9	R10	R11	R12	R13	R14	R15
99.1	93.8	84.6	91.7	98.1	90.0	92.2	88.2	74.3	84.0	87.1	65.4	98.3	91.0	95.6

TM30 C Values, 16 binned values out of total of 99 C values

C1	C2	C3	C4	C5	C6	C7	C8	C9	C10	C11	C12	C13	C14	C15	C16
92.0	97.4	93.8	92.6	88.6	92.9	95.0	94.4	92.3	86.0	79.5	88.6	89.9	90.0	83.5	92.6

CQS Q Values

Q1	Q2	Q3	Q4	Q5	Q6	Q7	Q8	Q9	Q10	Q11	Q12	Q13	Q14	Q15
95.7	97.4	82.2	85.8	94.2	93.8	93.1	98.3	91.6	92.0	96.0	98.1	96.2	98.3	97.9

CQS: 92.5

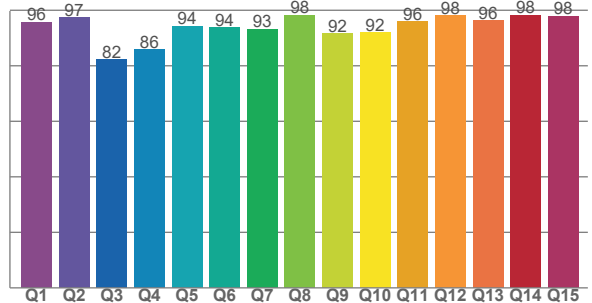

Color Parameters

Color Temperature	Color Rendering Index	Red Component	Color Fidelity	Color Gamut	Color Quality Scale	Color Coordinate CIE 1931	Color Coordinate CIE 1931	Color Coordinate	Color Coordinate	Color Diviation from Black
CCT	CRI	CRI R9	TM30 Rf	TM30 Rg	CQS	x	y	u	v	Δuv
6000 K	92.2	74.3	90.4	104.0	92.5	0.322	0.339	0.201	0.316	0.0004

TM30 Details

Rf 90.4
Fidelity Index Rf

Rg 104.0
Gamut Index Rg

Hue Bin	R _f	Graphic shifts (%)	
		Chroma	Hue
1	92	2%	-1%
2	97	0%	-1%
3	94	0%	1%
4	93	-1%	3%
5	89	-2%	3%
6	93	3%	2%
7	95	3%	-1%
8	94	-1%	0%
9	92	-3%	5%
10	86	-3%	8%
11	79	2%	13%
12	89	2%	8%
13	90	6%	6%
14	90	5%	2%
15	83	15%	-3%
16	93	3%	-2%

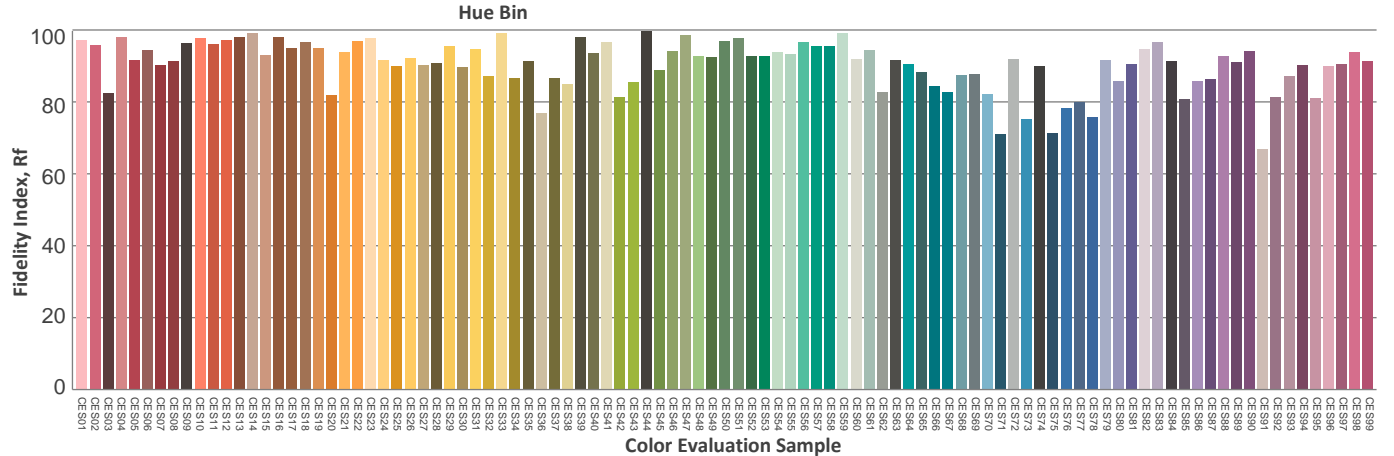
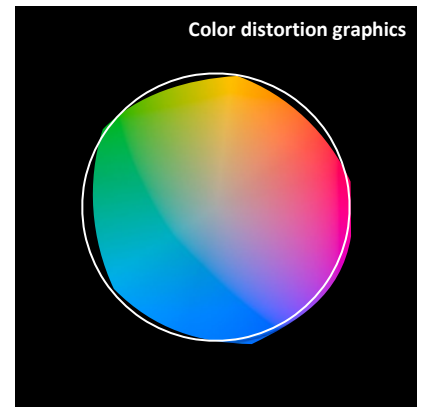
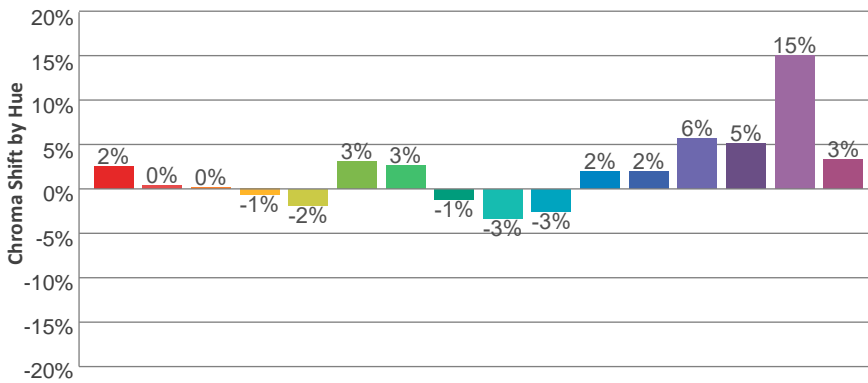
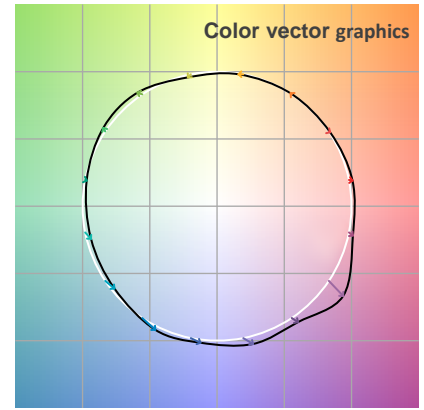
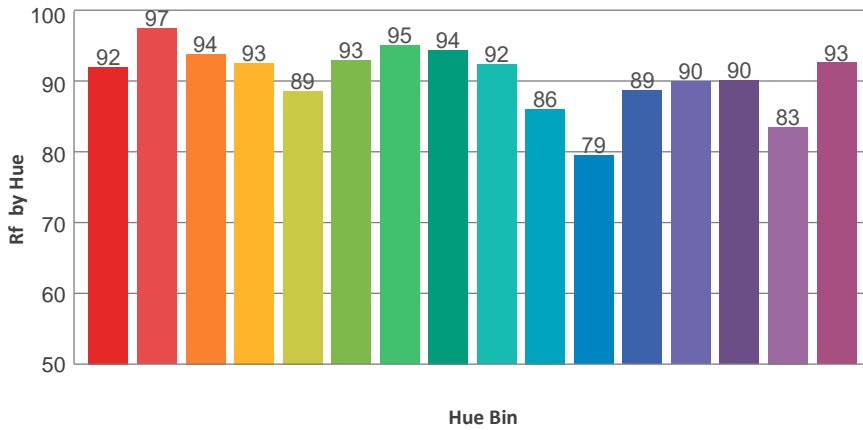
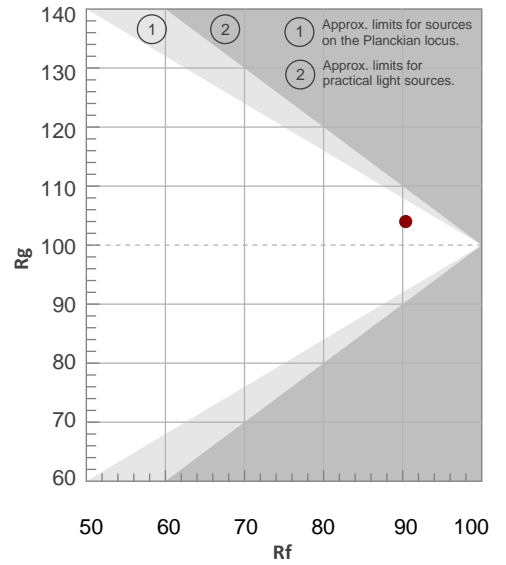

ISO Diagrams

ISO Candela Diagram

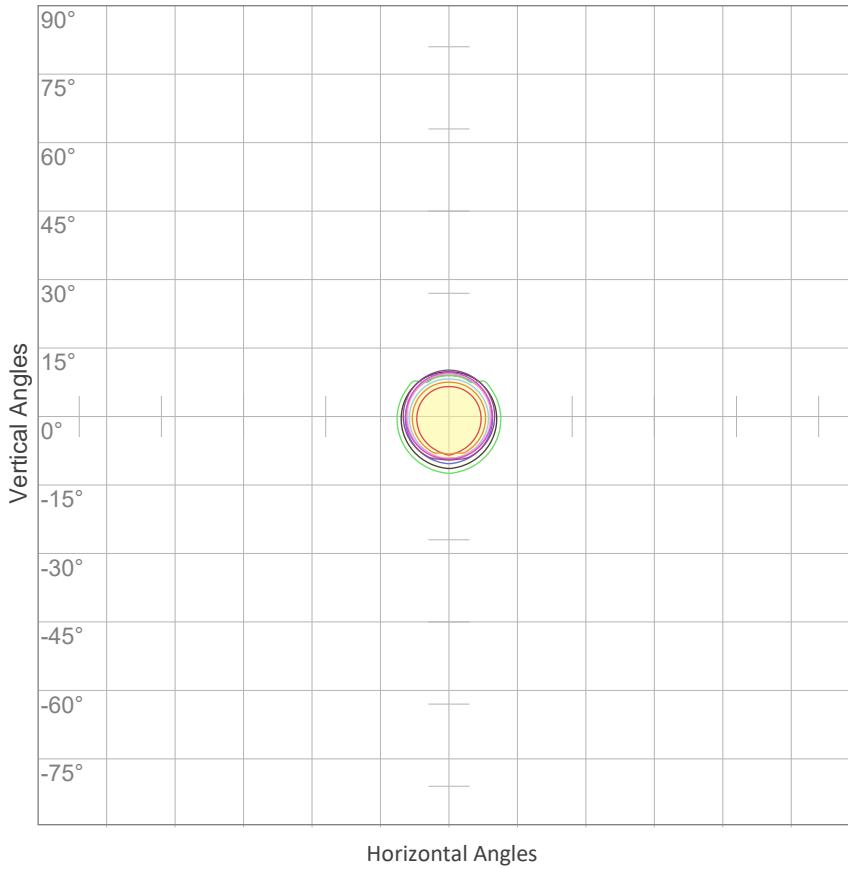

10%	14794 cd
20%	29587 cd
30%	44381 cd
40%	59174 cd
50%	73968 cd
60%	88761 cd
70%	103555 cd
80%	118348 cd
90%	133142 cd

Conditions:

Number of c-planes: 2

Candela at center: 147935 cd

ISO Lux Diagram

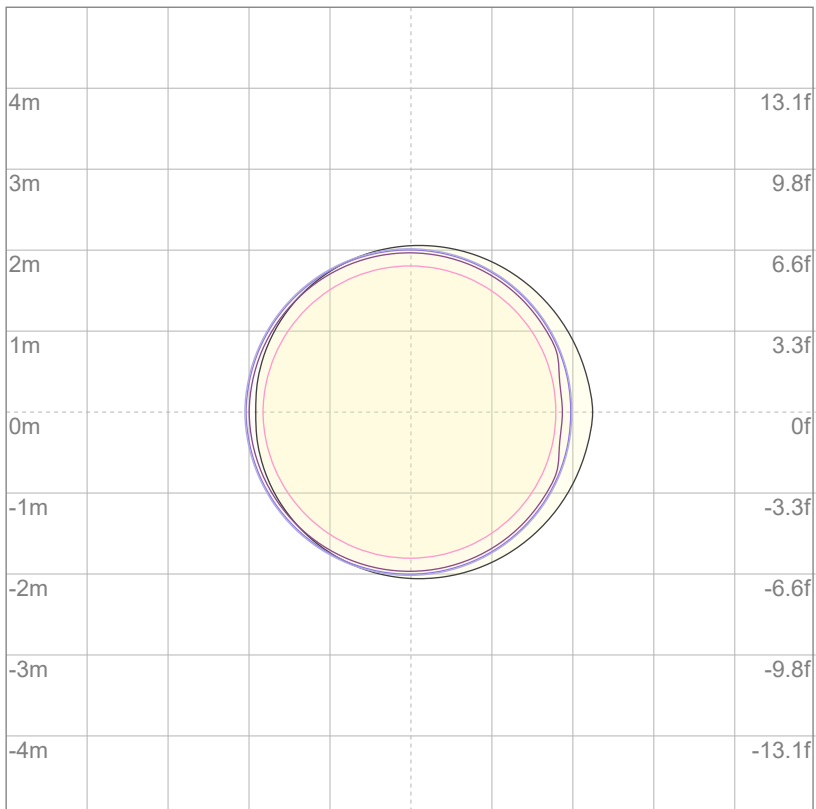

3%	44.4 lx
5%	74.0 lx
10%	148 lx
30%	444 lx
50%	740 lx

Conditions:

Number of c-planes: 2

Lux at center: 1479 lx

Lux distribution on a surface when lamp is mounted at 10 meters from the surface.

Mounting Height: 10 meters (33 feet)

Photometric Report

Total Lumen Output*

VISO Lab Spion 14012 lm

Beam Angle 50%	Field Angle 10%	Cutoff Angle 2.5%
19.8°	22°	22.4°

Color Temperature: 6536 K

CRI: 92.3

TLCI: 95

TM30: 89.9

CQS: 92.1

Voltage: 116 V, Current: 6.66 A

Power: 772 W

Efficacy: 18 Lumen/Watt

Measurement Date: 3/18/2022

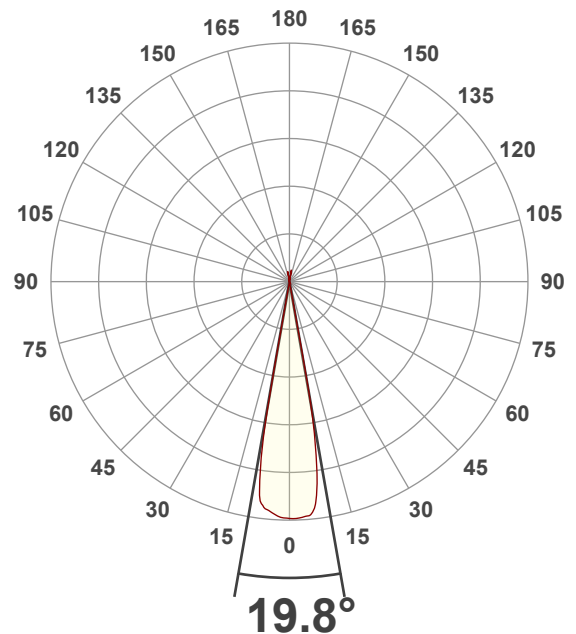

Spectral Distribution

Dominant Wavelength 507 nm

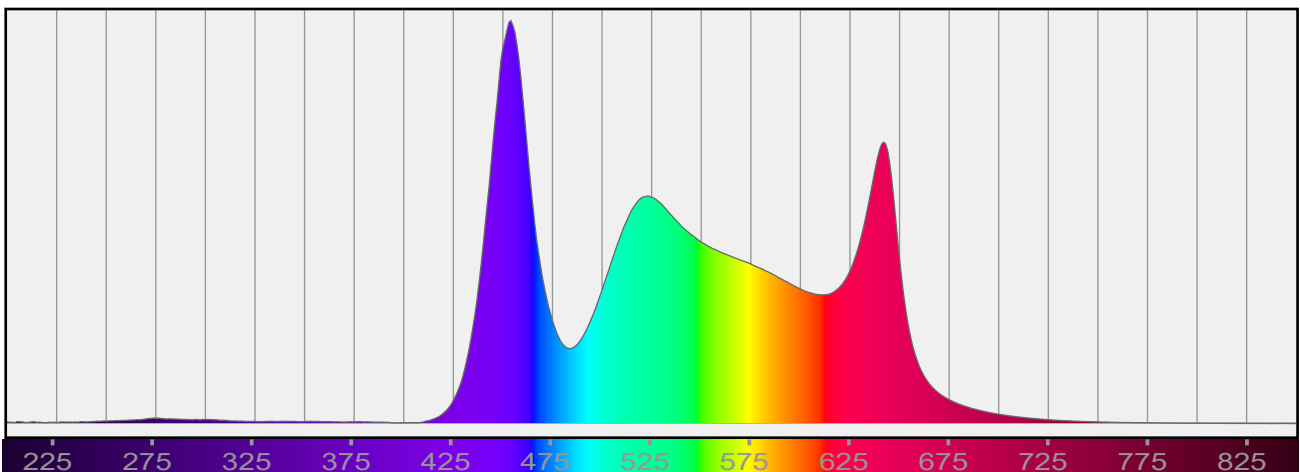

*Total Lumen measurements by calibrated Everfine 2π Integrating Sphere and Viso Systems Lab Spion

Beam Details

Beam Angle 50%	Field Angle 10%	Cutoff Angle 2,5%
19.8°	22°	22.4°

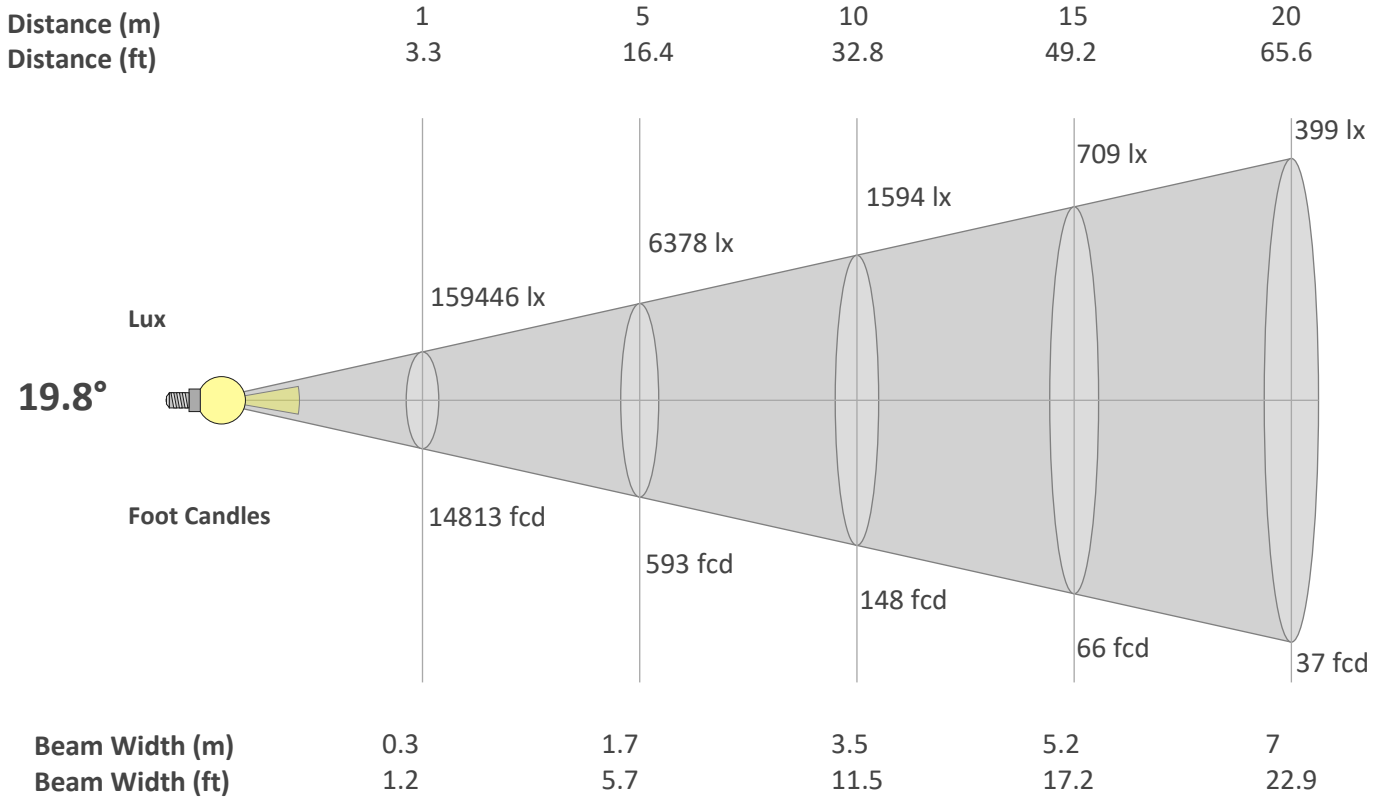

Beam Intensities from 1-20m

M	1	2	3	4	5	6	7	8	9	10	11	12	13	14	15	16	17	18	19	20
FT	3.3	6.6	9.8	13.1	16.4	19.7	23	26.2	29.5	32.8	36.1	39.4	42.7	45.9	49.2	52.5	55.8	59.1	62.3	65.6
LX	159446	39862	17716	9965	6378	4429	3254	2491	1968	1594	1318	1107	943	814	709	623	552	492	442	399
FC	14813	3703.3	1645.9	925.8	592.5	411.5	302.3	231.5	182.9	148.1	122.4	102.9	87.7	75.6	65.8	57.9	51.3	45.7	41	37

Linear Distribution

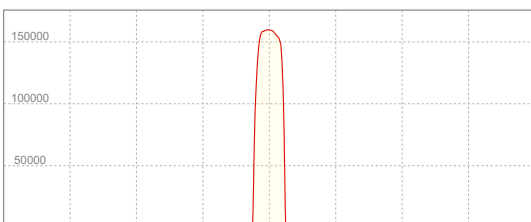

Peak Candela
159656 cd

Calculate Center Beam Intensities
 $lux = 159656 / distance(m)^2$
 $fc = 159656 / distance(ft)^2$

Color Details

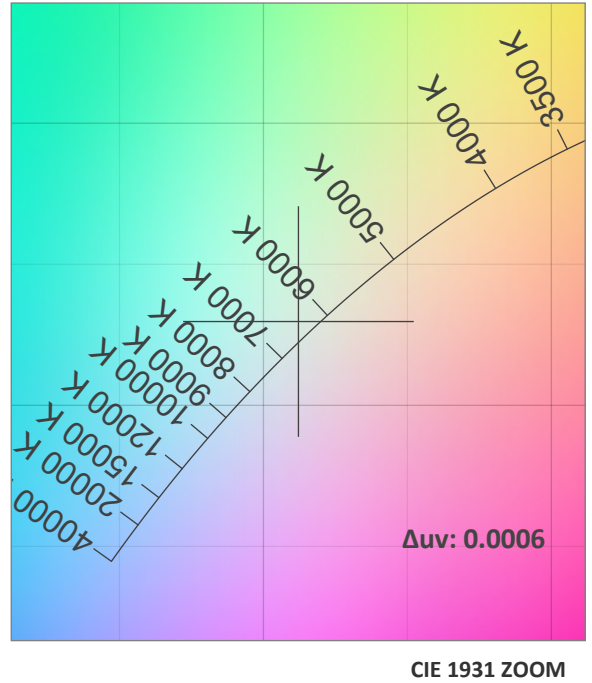
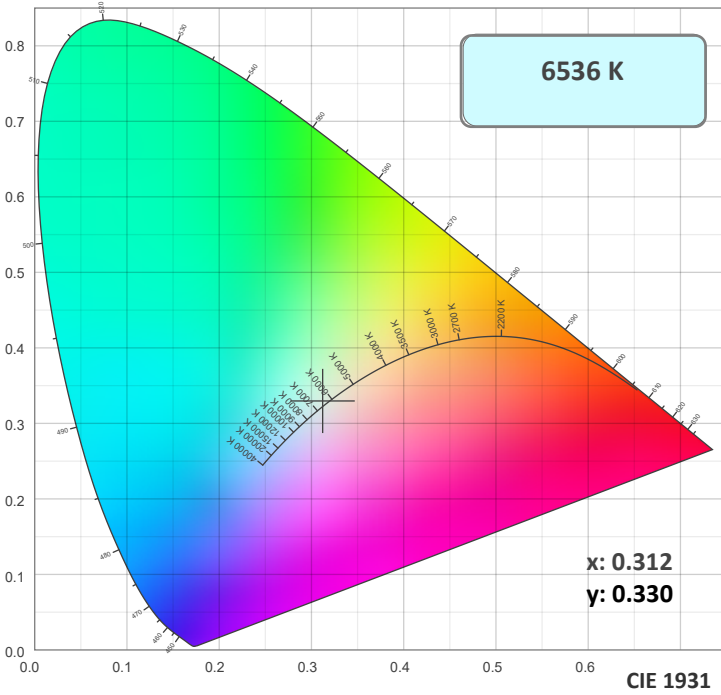

TM30: 89.9

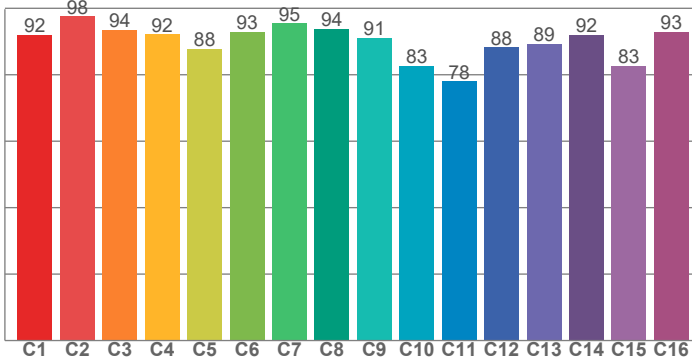

CRI: 92.3 (R1-R8)

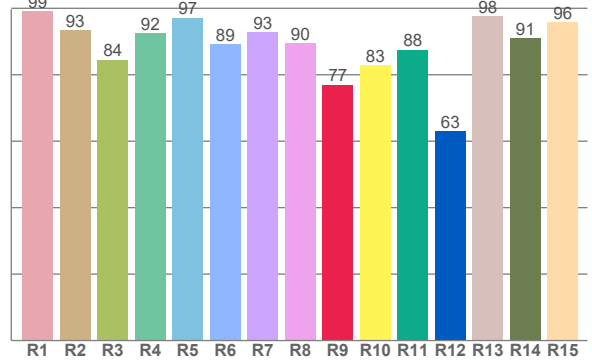

CRI R values, only R1-R8 are used to calculate final CRI value

R1	R2	R3	R4	R5	R6	R7	R8	R9	R10	R11	R12	R13	R14	R15
99.2	93.4	84.5	92.4	97.2	89.2	92.8	89.5	77.0	82.8	87.6	63.0	97.6	91.0	95.8

TM30 C Values, 16 binned values out of total of 99 C values

C1	C2	C3	C4	C5	C6	C7	C8	C9	C10	C11	C12	C13	C14	C15	C16
92.0	97.6	93.5	92.2	87.9	92.9	95.5	93.8	91.2	82.7	78.0	88.2	89.3	92.0	82.8	92.9

CQS Q Values

Q1	Q2	Q3	Q4	Q5	Q6	Q7	Q8	Q9	Q10	Q11	Q12	Q13	Q14	Q15
95.8	97.5	81.6	84.1	92.9	94.2	93.1	98.3	91.5	91.5	95.3	97.8	96.5	98.6	97.9

CQS: 92.1

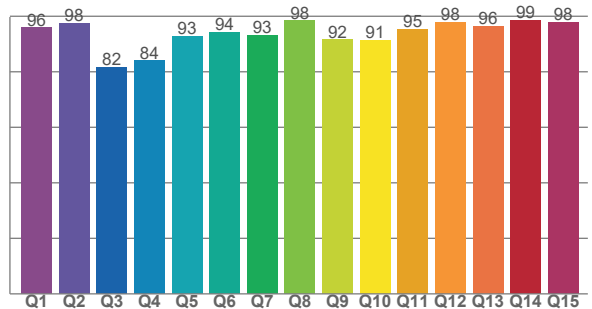

Color Parameters

Color Temperature	Color Rendering Index	Red Component	Color Fidelity	Color Gamut	Color Quality Scale	Color Coordinate CIE 1931	Color Coordinate CIE 1931	Color Coordinate	Color Coordinate	Color Diviation from Black
CCT	CRI	CRI R9	TM30 Rf	TM30 Rg	CQS	x	y	u	v	Δuv
6536 K	92.3	77.0	89.9	102.9	92.1	0.312	0.330	0.197	0.312	0.0006

TM30 Details

Rf 89.9
Fidelity Index Rf

Rg 102.9
Gamut Index Rg

Hue Bin	R _f	Graphic shifts (%)	
		Chroma	Hue
1	92	2%	-1%
2	98	0%	-1%
3	94	0%	1%
4	92	-1%	3%
5	88	-2%	2%
6	93	2%	2%
7	95	2%	-1%
8	94	-2%	1%
9	91	-4%	7%
10	83	-3%	12%
11	78	1%	13%
12	88	2%	8%
13	89	6%	6%
14	92	3%	1%
15	83	16%	-4%
16	93	3%	-2%

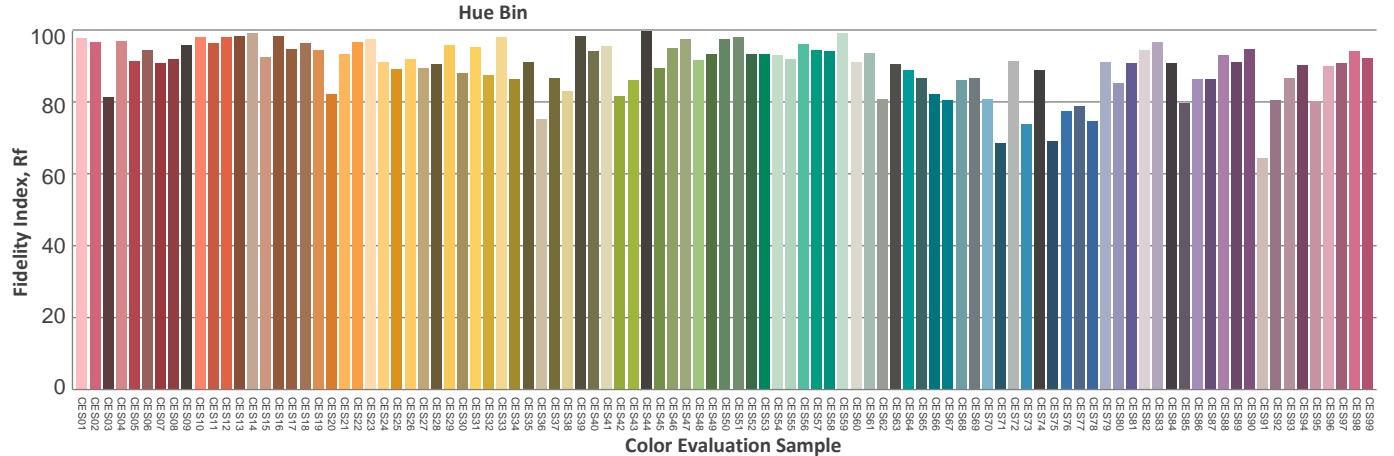
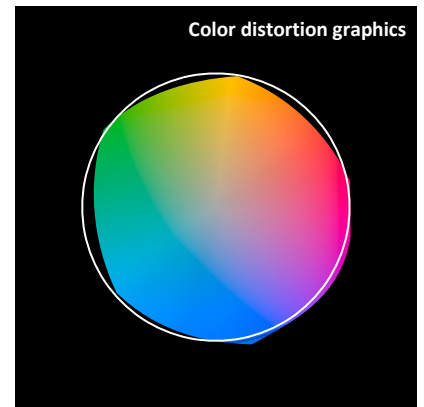
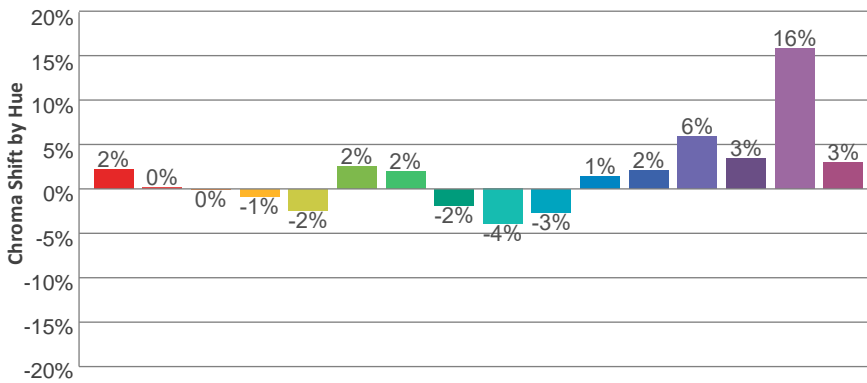
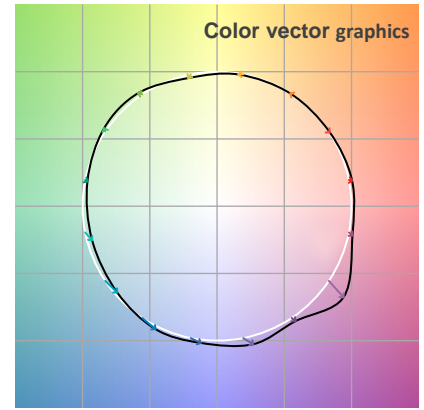
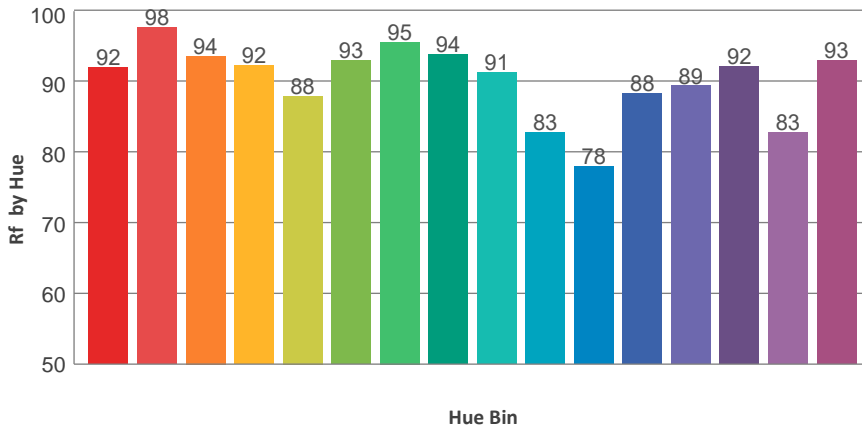
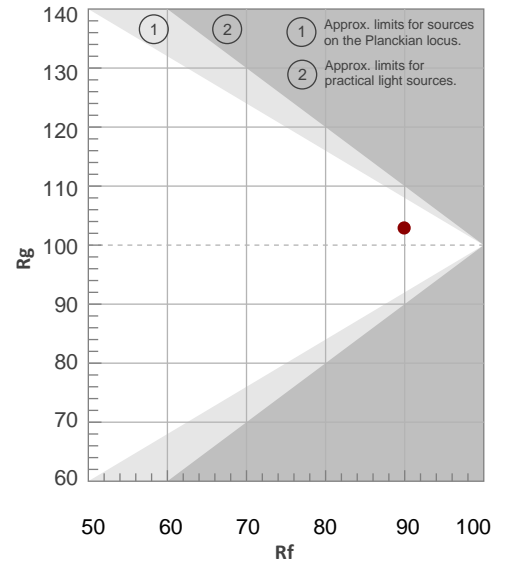

ISO Diagrams

ISO Candela Diagram

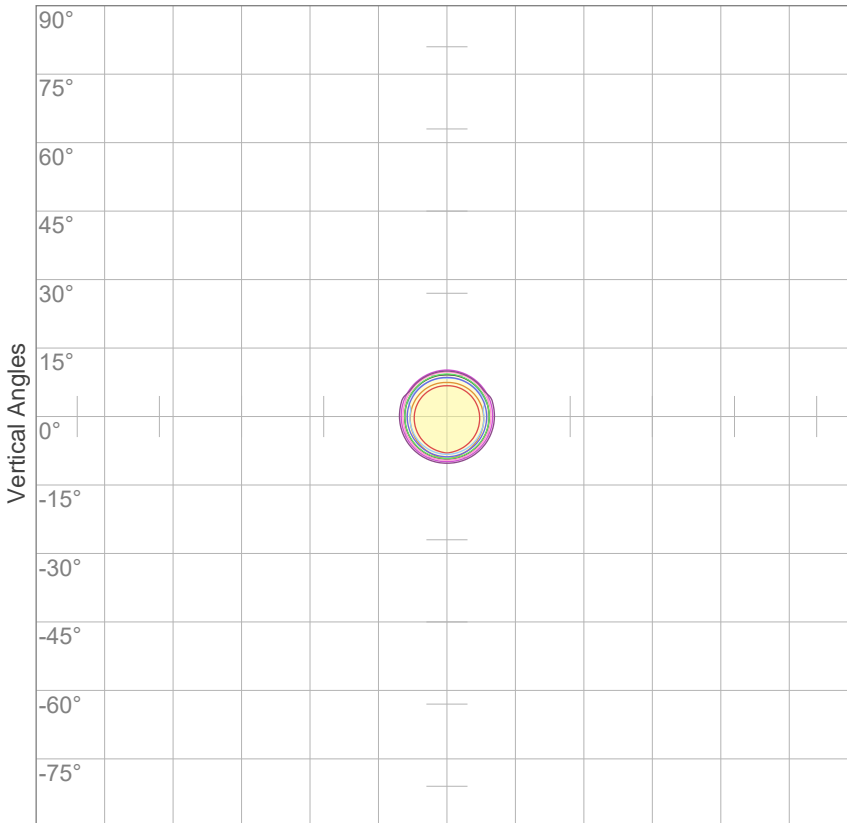

10%	15945 cd
20%	31889 cd
30%	47834 cd
40%	63778 cd
50%	79723 cd
60%	95668 cd
70%	111612 cd
80%	127557 cd
90%	143501 cd

Conditions:
 Number of c-planes: 2
 Candela at center: 159446 cd

ISO Lux Diagram

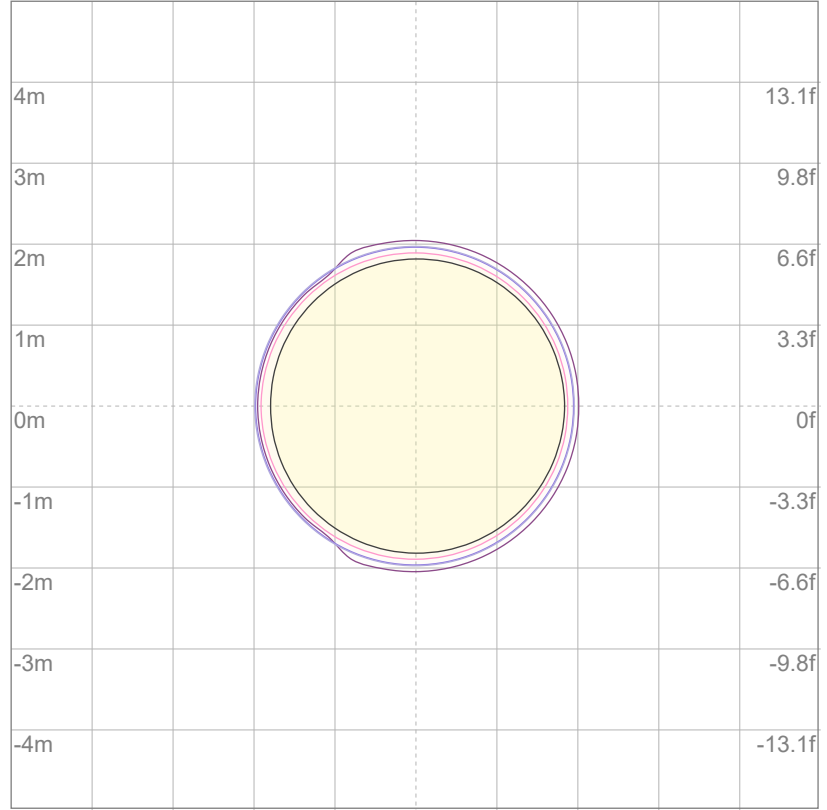

3%	47.8 lx
5%	79.7 lx
10%	159 lx
30%	478 lx
50%	797 lx

Conditions:
 Number of c-planes: 2
 Lux at center: 1594 lx

Lux distribution on a surface when lamp is mounted at 10 meters from the surface.

Mounting Height: 10 meters (33 feet)

Total Lumen Output: 1134 lm

Voltage: 119 V, Current: 1.52 A

Power: 181.2 W

Efficacy: 6 Lumen/Watt

Measurement Date: 3/18/2022

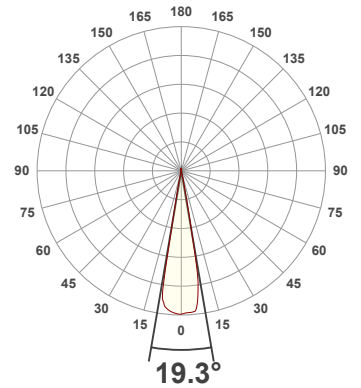
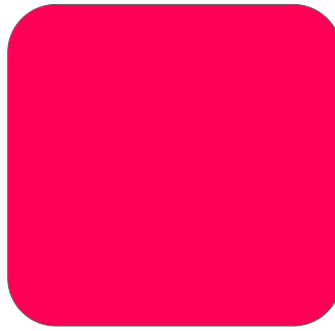

Spectral distribution

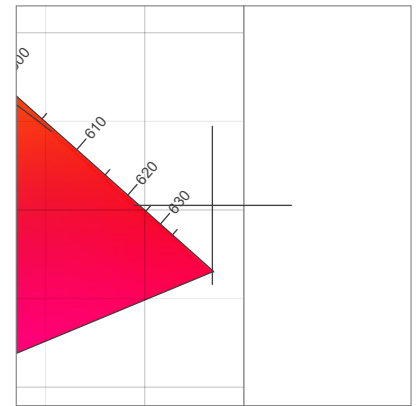
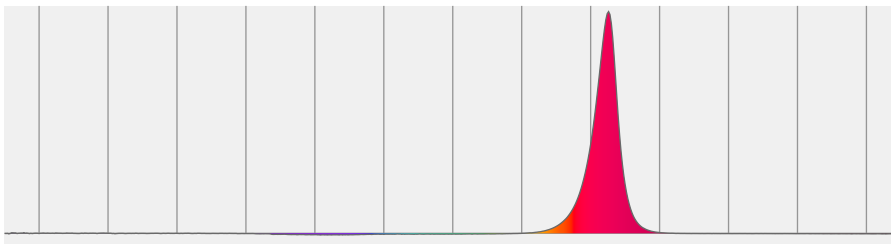

Dominant Wavelength	Color coordinate cie 1931	Color coordinate cie 1931	Color coordinate	Color coordinate
nm	x	y	u	v
622	0.734	0.303	0.569	0.352

Beam details

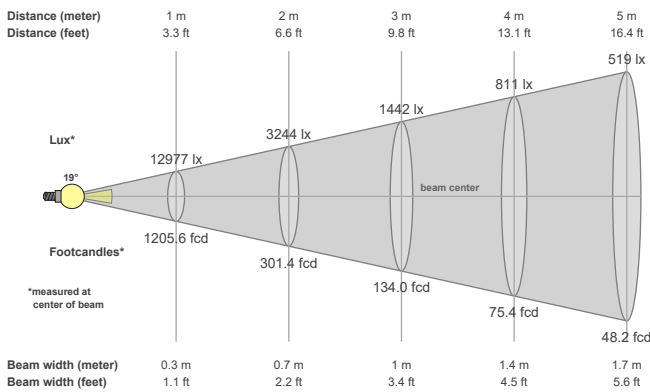

Beam angles

Beam angle 50%	Field angle 10%	Cutoff angle 2,5%
19.3°	22.5°	23.6°

Beam intensities

Peak intensity	Int. ratio in 120° cone	Int. ratio in 90° cone
12978 cd	100.0%	100.0%

Beam Intensities from 1-20m

M	1	2	3	4	5	6	7	8	9	10	11	12	13	14	15	16	17	18	19	20
FT	3.3	6.6	9.8	13.1	16.4	19.7	23	26.2	29.5	32.8	36.1	39.4	42.7	45.9	49.2	52.5	55.8	59.1	62.3	65.6
LX	12977	3244	1442	811	519	360	265	203	160	130	107	90	77	66	58	51	45	40	36	32
FC	1205.6	301.4	134	75.4	48.2	33.5	24.6	18.8	14.9	12.1	10	8.4	7.1	6.2	5.4	4.7	4.2	3.7	3.3	3

Total Lumen Output: 2811 lm

Voltage: 118 V, Current: 2.37 A

Power: 280 W

Efficacy: 10 Lumen/Watt

Measurement Date: 3/18/2022

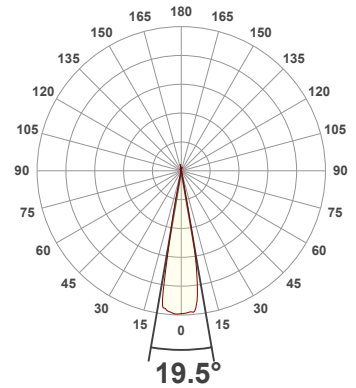
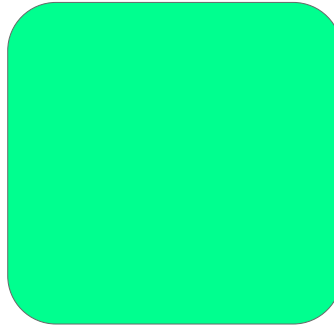

Spectral distribution

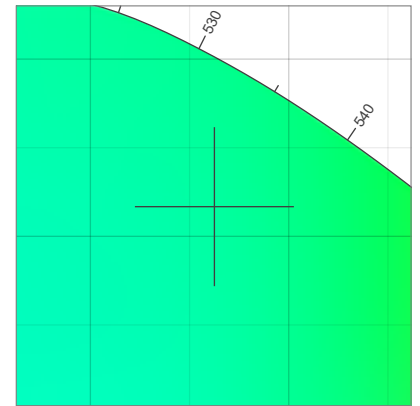
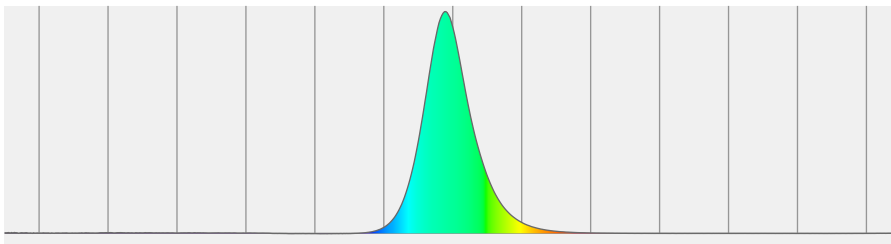

Dominant Wavelength	Color coordinate cie 1931	Color coordinate cie 1931	Color coordinate	Color coordinate
nm	x	y	u	v
526	0.163	0.717	0.058	0.381

Beam details

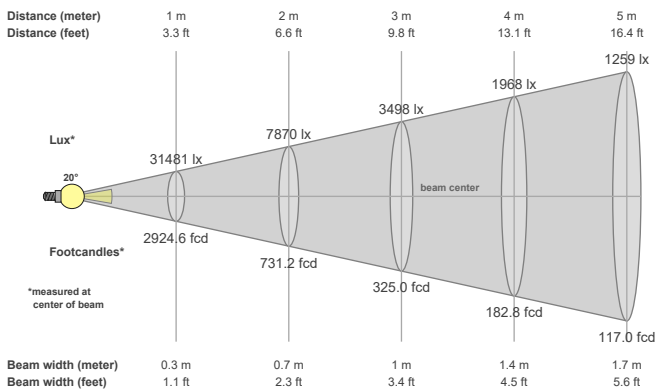

Beam angles

Beam angle 50%	Field angle 10%	Cutoff angle 2,5%
19.5°	23°	23.7°

Beam intensities

Peak intensity	Int. ratio in 120° cone	Int. ratio in 90° cone
31582 cd	100.0%	100.0%

Beam Intensities from 1-20m

M	1	2	3	4	5	6	7	8	9	10	11	12	13	14	15	16	17	18	19	20
FT	3.3	6.6	9.8	13.1	16.4	19.7	23	26.2	29.5	32.8	36.1	39.4	42.7	45.9	49.2	52.5	55.8	59.1	62.3	65.6
LX	31481	7870	3498	1968	1259	874	642	492	389	315	260	219	186	161	140	123	109	97	87	79
FC	2924.6	731.2	325	182.8	117	81.2	59.7	45.7	36.1	29.2	24.2	20.3	17.3	14.9	13	11.4	10.1	9	8.1	7.3

Total Lumen Output: 691 lm

Voltage: 120 V, Current: 0.000 A

Power: - W

Efficacy: n/a Lumen/Watt

Measurement Date: 3/18/2022

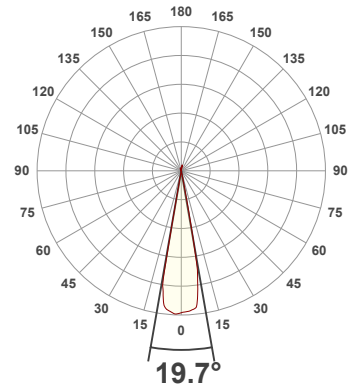
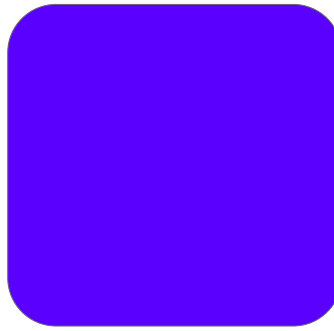

Spectral distribution

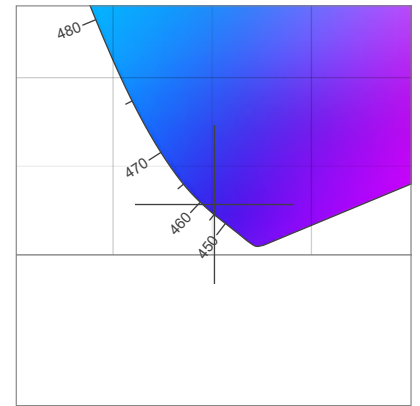
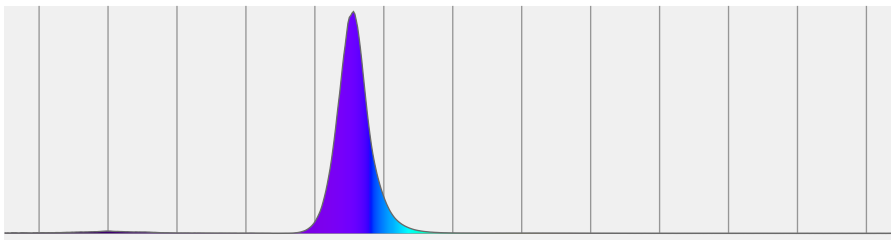

Dominant Wavelength	Color coordinate cie 1931	Color coordinate cie 1931	Color coordinate	Color coordinate
nm	x	y	u	v
456	0.151	0.028	0.199	0.056

Beam details

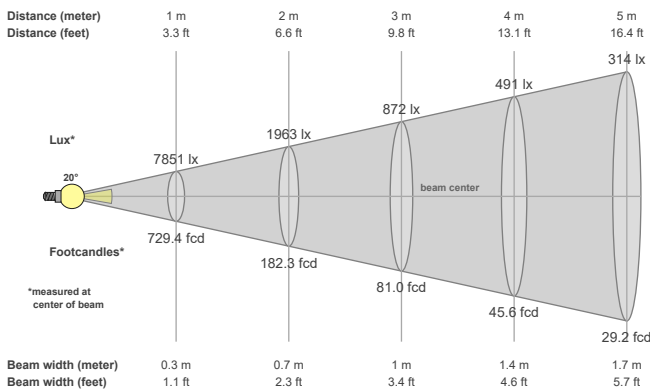

Beam angles

Beam angle 50%	Field angle 10%	Cutoff angle 2,5%
19.7°	21.5°	22°

Beam intensities

Peak intensity	Int. ratio in 120° cone	Int. ratio in 90° cone
7927 cd	100.0%	100.0%

Beam Intensities from 1-20m

M	1	2	3	4	5	6	7	8	9	10	11	12	13	14	15	16	17	18	19	20
FT	3.3	6.6	9.8	13.1	16.4	19.7	23	26.2	29.5	32.8	36.1	39.4	42.7	45.9	49.2	52.5	55.8	59.1	62.3	65.6
LX	7851	1963	872	491	314	218	160	123	97	79	65	55	46	40	35	31	27	24	22	20
FC	729.4	182.3	81	45.6	29.2	20.3	14.9	11.4	9	7.3	6	5.1	4.3	3.7	3.2	2.8	2.5	2.3	2	1.8

Total Lumen Output: 13429 lm

Voltage: 118 V, Current: 3.99 A

Power: 471.1 W

Efficacy: 29 Lumen/Watt

Measurement Date: 3/18/2022

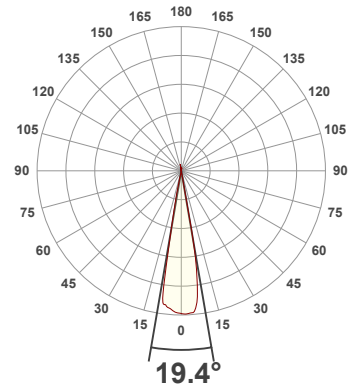
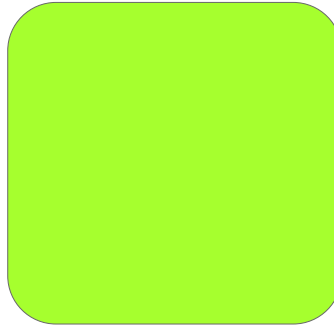

Spectral distribution

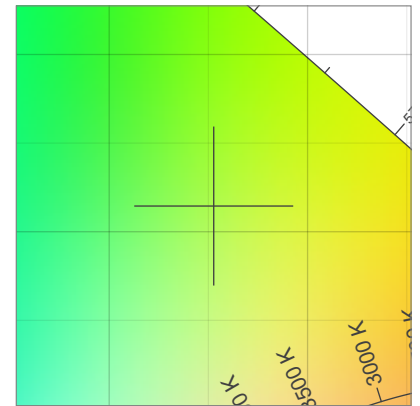
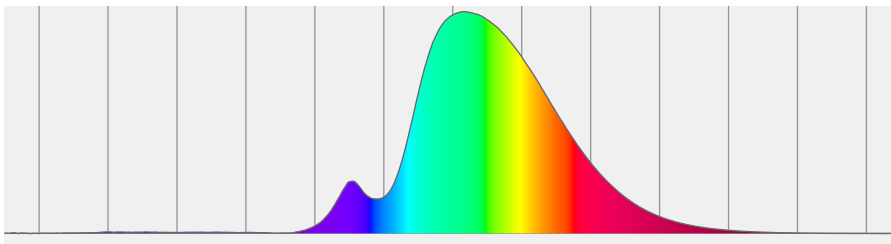

Dominant Wavelength	Color coordinate cie 1931	Color coordinate cie 1931	Color coordinate	Color coordinate
nm	x	y	u	v
560	0.353	0.514	0.167	0.365

Beam details

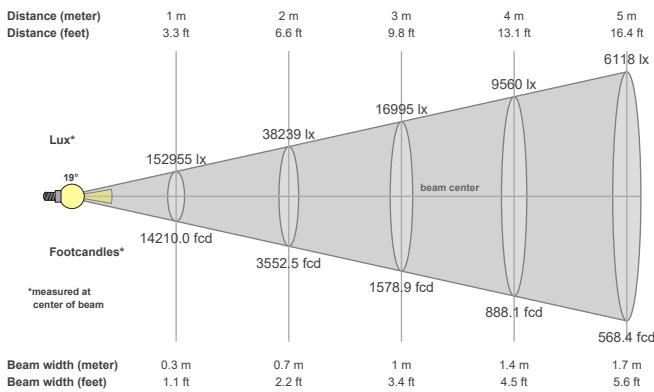

Beam angles

Beam angle 50%	Field angle 10%	Cutoff angle 2,5%
19.4°	22.9°	23.7°

Beam intensities

Peak intensity	Int. ratio in 120° cone	Int. ratio in 90° cone
153655 cd	100.0%	100.0%

Beam Intensities from 1-20m

M	1	2	3	4	5	6	7	8	9	10	11	12	13	14	15	16	17	18	19	20
FT	3.3	6.6	9.8	13.1	16.4	19.7	23	26.2	29.5	32.8	36.1	39.4	42.7	45.9	49.2	52.5	55.8	59.1	62.3	65.6
LX	152955	38239	16995	9560	6118	4249	3122	2390	1888	1530	1264	1062	905	780	680	597	529	472	424	382
FC	14210	3552.5	1578.9	888.1	568.4	394.7	290	222	175.4	142.1	117.4	98.7	84.1	72.5	63.2	55.5	49.2	43.9	39.4	35.5

Total Lumen Output: 2572 lm

Voltage: 118 V, Current: 2.44 A

Power: 288 W

Efficacy: 9 Lumen/Watt

Measurement Date: 3/18/2022

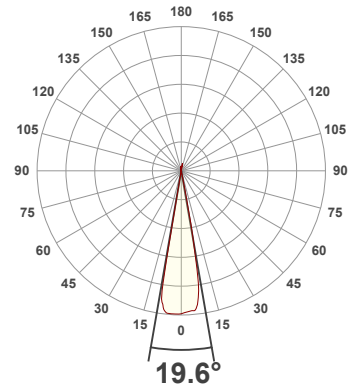
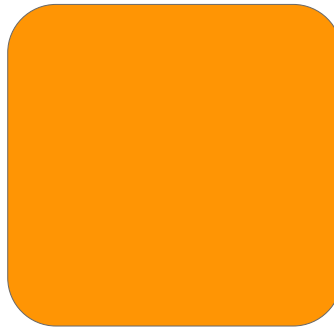

Spectral distribution

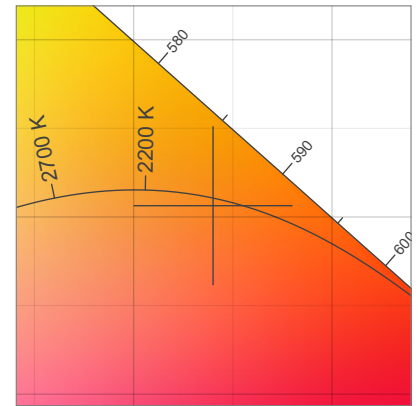
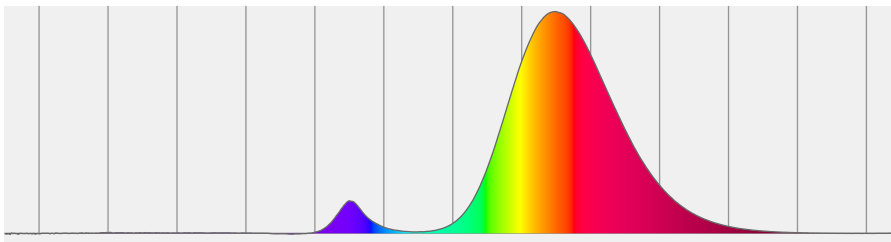

Dominant Wavelength	Color coordinate cie 1931	Color coordinate cie 1931	Color coordinate	Color coordinate
nm	x	y	u	v
591	0.540	0.406	0.318	0.359

Beam details

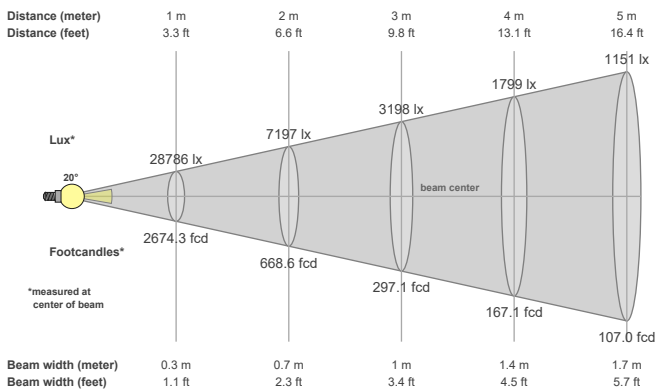

Beam angles

Beam angle 50%	Field angle 10%	Cutoff angle 2,5%
19.6°	21.9°	22.4°

Beam intensities

Peak intensity	Int. ratio in 120° cone	Int. ratio in 90° cone
28867 cd	100.0%	100.0%

Beam Intensities from 1-20m

M	1	2	3	4	5	6	7	8	9	10	11	12	13	14	15	16	17	18	19	20
FT	3.3	6.6	9.8	13.1	16.4	19.7	23	26.2	29.5	32.8	36.1	39.4	42.7	45.9	49.2	52.5	55.8	59.1	62.3	65.6
LX	28786	7197	3198	1799	1151	800	587	450	355	288	238	200	170	147	128	112	100	89	80	72
FC	2674.3	668.6	297.1	167.1	107	74.3	54.6	41.8	33	26.7	22.1	18.6	15.8	13.6	11.9	10.4	9.3	8.3	7.4	6.7