



SIXPAR 200WMG™

SKU# SIX123

The IP65 outdoor rated SIXPAR 200WMG includes the same features as the standard SIXPAR 200IP model but with a special added White Marine Grade exterior coating designed for the marine/coastal environment installations. Featuring (12) 12W 6-in-1 RGBAW+UV LEDs producing a 23° beam angle, internal color and color chase macros, electronic strobe and variable dimming curve modes, manual and DMX-512 control, RDM (remote device management) support, dual yoke / floor stand, multiple unit power linking, rugged die-cast aluminum white marine grade coated exterior, flicker free operation for TV and FILM, and a multi-voltage universal auto switching power supply (110-250v).

FEATURES

- IP65 Outdoor Rated Par Luminaire**
- Special White Marine Grade Exterior Coating**
- Rugged Die-Cast Aluminum Exterior with Dual Yoke**
- (12) 12W 6-in-1 RGBAW+UV LEDs**
- 23° Beam Angle**
- 395nm UV Wavelength**
- Electronic Strobe and Variable Dimming Curve Modes**
- Manual and DMX-512 Control**
- RDM (Remote Device Management) Support**
- Multiple Unit Power Linking**
- Proprietary IP Rated Power/Data In/Out Cables Attached**
- Optional Extended Length Cables Available**



PRODUCT SPECIFICATIONS

SOURCE

(12) 12W 6-in-1 RGBAW+UV LEDs
 100,000 Hour Average LED Life*

*May vary depending on several factors including but not limited to: Environmental Conditions, Power/Voltage, Usage Patterns (On-Off Cycling), Control, Dimming, and Lamp Mode.

PHOTOMETRIC DATA

2,100 Total Lumen Output

EFFECTS

Electronic Strobe
 Color and Chase Macros
 Electronic Dimming: 0% - 100%
 5 Variable Dimming Curve Modes

CONTROL / CONNECTIONS

(4) DMX Channel Modes (6 / 7 / 8 / 12)
 (4) Button Touch Control Panel
 LCD Menu Display
 IP DMX In/Out
 IP Power In/Out

SIZE / WEIGHT

Length: 12.3" (313mm)
 Width: 6.2" (157mm)
 Vertical Height: 11.8" (300mm)
 Weight: 12.6 lbs. (5.7 kg)

ELECTRICAL / THERMAL

AC 110-250V - 50/60Hz
 150W Max Power Consumption
 Power Linking: 8pcs @110V / 18pcs @240V
 68°F to 113°F (20°C to 45°C)

APPROVALS / RATINGS



INCLUDED ITEMS

Male Edison to IP Female Power WH Cable 6.6 ft. (2m)
 Male 3pin XLR to IP Female DMX Input WH Cable 3.3 ft (1m)
 Female 3pin XLR to IP Male DMX Output WH Cable 3.3 ft (1m)

DIMENSIONAL DRAWINGS

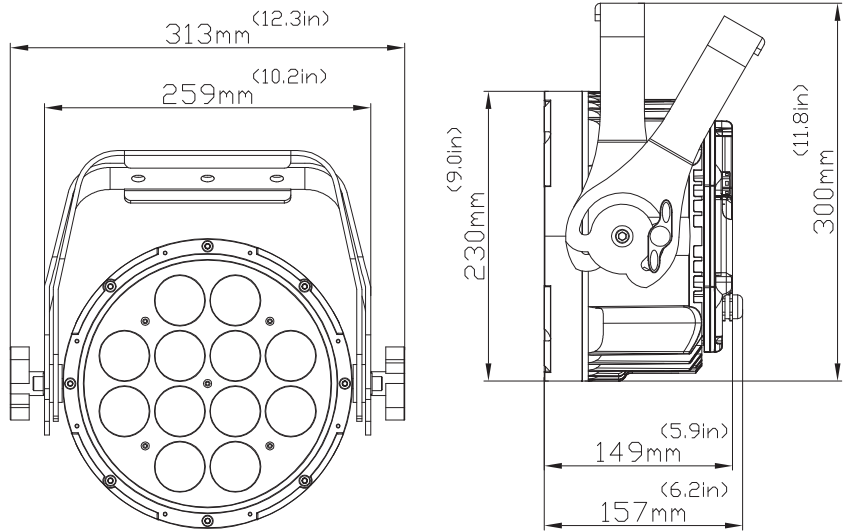

ATTACHED POWER AND DATA IN/OUT CABLES



OPTIONAL ACCESSORIES

ORDER CODE	ITEM
NARROW CLAMP	Aluminum Pro 2-inch Wrap Around Style Clamp Max 350 lbs.
EWD001	EWDMX IP Wireless IP65 DMX Transceiver
SIXPAR/1MDLC/WH	6.6 ft. (1m) IP Data Link Cable WHITE
SIXPAR/1MPLC/WH	6.6 ft. (1m) IP Power Link Cable WHITE **SPECIAL ORDER ITEM**
SIXPAR/2MDLC	6.6 ft. (2m) IP Data Link Cable WHITE
SIXPAR/2MPLC	6.6 ft. (2m) IP Power Link Cable WHITE
SIXPAR/10MDLC/WH	32.8 ft. (10m) IP Data Link Cable WHITE **SPECIAL ORDER ITEM**
SIXPAR/10MPLC/WH	32.8 ft. (10m) IP Power Link Cable WHITE **SPECIAL ORDER ITEM**
SIXPAR/20MDLC/WH	65.6 ft. (20m) IP Data Link Cable WHITE **SPECIAL ORDER ITEM**
SIXPAR/20MPLC/WH	65.6 ft. (20m) IP Power Link Cable WHITE **SPECIAL ORDER ITEM**
SIXPAR/DIAC/WH	Data IN IP Adapter Cable
SIXPAR/DOAC/WH	Data OUT IP Adapter Cable
SIXPAR/PIAC/WH	Power IN IP Adapter Cable
SIXPAR/POAC/WH	Power OUT IP Adapter Cable
SIXPAR/TERMINATOR/WH	DMX Terminator End Cap
5060400106	300 ft. (91.5m) IP WHITE Bulk Data Cable for SIXPAR