



RAYZOR 360Z™

user manual

©2020 ELATION PROFESSIONAL all rights reserved. Information, specifications, diagrams, images, and instructions herein are subject to change without notice. ELATION PROFESSIONAL logo and identifying product names and numbers herein are trademarks of ELATION PROFESSIONAL. Copyright protection claimed includes all forms and matters of copyrightable materials and information now allowed by statutory or judicial law or hereinafter granted. Product names used in this document may be trademarks or registered trademarks of their respective companies and are hereby acknowledged. All non-ELATION brands and product names are trademarks or registered trademarks of their respective companies.

ELATION PROFESSIONAL and all affiliated companies hereby disclaim any and all liabilities for property, equipment, building, and electrical damages, injuries to any persons, and direct or indirect economic loss associated with the use or reliance of any information contained within this document, and/or as a result of the improper, unsafe, insufficient and negligent assembly, installation, rigging, and operation of this product.

Elation Professional USA | 6122 S. Eastern Ave. | Los Angeles, CA. 90040
 323-582-3322 | 323-832-9142 fax | www.elationlighting.com | info@elationlighting.com

Elation Professional B.V. | Junostraat 2 | 6468 EW Kerkrade, The Netherlands
 +31 45 546 85 66 | +31 45 546 85 96 fax | www.elationlighting.eu | info@elationlighting.eu

Elation Professional Mexico | AV Santa Ana 30 | Parque Industrial Lerma, Lerma, Mexico 52000
 +52 (728) 282-7070

DOCUMENT VERSION



Due to additional product features and/or enhancements, an updated version of this document may be available online. Please scan the QR Code with your mobile device or visit www.elationlighting.com for the latest revision/update of this manual, before installation and/or programming.

Date	Document Version	Software Version ≥	DMX Channel Modes	Notes
01/05/17	1.2	2.0.1	20 / 26 / 32	Updated White Balance instructions.
02/01/17	1.3	N/C	NO CHANGE	Corrected Chase Patterns DMX value error.
01/19/18	2	2.0.4	NO CHANGE	Added Kling-Net and Art-Net ver 4 Support.
01/18/19	2.2	N/C	NO CHANGE	Updated manual format.
02/25/19	2.4	N/C	NO CHANGE	Updated light damage illustration.
08/24/20	2.6	N/C	NO CHANGE	Updated thermal, and zoom range
10/16/20	2.8	N/C	NO CHANGE	Updated specifications
12/10/20	3.0	2.0.8	NO CHANGE	Updated primary/secondary modes

CONTENTS

General Information	4
Limited Warranty (USA Only)	5
Safety Guidelines	6
Maintenance Guidelines	8
Fixture Overview	9
Installation Guidelines	10
System Menu	14
DMX Channel Functions and Values	23
LED Pixel Control	26
Error Codes	27
Specifications	28
Optional Accessories	31

GENERAL INFORMATION

INTRODUCTION

Please read and understand the instructions in this manual carefully and thoroughly before attempting to operate this device. These instructions contain important safety and use information.

UNPACKING

Every device has been thoroughly tested and has been shipped in perfect operating condition. Carefully check the shipping carton for damage that may have occurred during shipping. If the carton is damaged, carefully inspect the device for damage, and be sure all accessories necessary to install and operate the device have arrived intact. In the event damage has been found or parts are missing, please contact our customer support team for further instructions. Please do not return this device to your dealer without first contacting customer support. Please do not discard the shipping carton in the trash. Please recycle whenever possible.

BOX CONTENTS

Omega Bracket
Power Cable

CUSTOMER SUPPORT

Contact ELATION Service for any product related service and support needs. Also visit forums.elationlighting.com with questions, comments or suggestions.

ELATION SERVICE USA - Monday - Friday 8:00am to 4:30pm PST
323-582-3322 | Fax 323-832-9142 | support@elationlighting.com

ELATION SERVICE EUROPE - Monday - Friday 08:30 to 17:00 CET
+31 45 546 85 63 | Fax +31 45 546 85 96 | support@elationlighting.eu

REPLACEMENT PARTS please visit parts.elationlighting.com



I M P O R T A N T N O T I C E !

THERE ARE NO USER SERVICEABLE PARTS INSIDE THIS UNIT. DO NOT ATTEMPT ANY REPAIRS YOURSELF; DOING SO WILL VOID YOUR MANUFACTURES WARRANTY. DAMAGES RESULTING FROM MODIFICATIONS TO THIS FIXTURE AND/OR THE DISREGARD OF SAFETY INSTRUCTIONS AND GUIDELINES IN THIS MANUAL VOID THE MANUFACTURES WARRANTY AND ARE NOT SUBJECT TO ANY WARRANTY CLAIMS AND/OR REPAIRS.

LIMITED WARRANTY (USA ONLY)

A. Elation Professional hereby warrants, to the original purchaser, Elation Professional products to be free of manufacturing defects in material and workmanship for a period of two years (730 days), and Elation Professional product rechargeable batteries to be free of manufacturing defects in material and workmanship for a period of six months (180 days), from the original date of purchase. This warranty excludes discharge lamps and all product accessories. This warranty shall be valid only if the product is purchased within the United States of America, including possessions and territories. It is the owner's responsibility to establish the date and place of purchase by acceptable evidence, at the time service is sought. B. For warranty service, send the product only to the Elation Professional factory. All shipping charges must be pre-paid. If the requested repairs or service (including parts replacement) are within the terms of this warranty, Elation Professional will pay return shipping charges only to a designated point within the United States. If any product is sent, it must be shipped in its original package and packaging material. No accessories should be shipped with the product. If any accessories are shipped with the product, Elation Professional shall have no liability what so ever for loss and/or or damage to any such accessories, nor for the safe return thereof. C. This warranty is void if the product serial number and/or labels are altered or removed; if the product is modified in any manner which Elation Professional concludes, after inspection, affects the reliability of the product; if the product has been repaired or serviced by anyone other than the Elation Professional factory unless prior written authorization was issued to purchaser by Elation Professional; if the product is damaged because not properly maintained as set forth in the product instructions, guidelines and/or user manual. D. This is not a service contract, and this warranty does not include any maintenance, cleaning or periodic check-up. During the periods as specified above, Elation Professional will replace defective parts at its expense, and will absorb all expenses for warranty service and repair labor by reason of defects in material or workmanship. The sole responsibility of Elation Professional under this warranty shall be limited to the repair of the product, or replacement thereof, including parts, at the sole discretion of Elation Professional. All products covered by this warranty were manufactured after January 1, 1990, and bare identifying marks to that effect. E. Elation Professional reserves the right to make changes in design and/or performance improvements upon its products without any obligation to include these changes in any products theretofore manufactured. F. No warranty, whether expressed or implied, is given or made with respect to any accessory supplied with the products described above. Except to the extent prohibited by applicable law, all implied warranties made by Elation Professional in connection with this product, including warranties of merchantability or fitness, are limited in duration to the warranty periods set forth above. And no warranties, whether expressed or implied, including warranties of merchantability or fitness, shall apply to this product after said periods have expired. The consumer's and/or dealer's sole remedy shall be such repair or replacement as is expressly provided above; and under no circumstances shall Elation Professional be liable for any loss and/or damage, direct and/or consequential, arising out of the use of, and/or the inability to use, this product. G. This warranty is the only written warranty applicable to Elation Professional products and supersedes all prior warranties and written descriptions of warranty terms and conditions heretofore published.

WARRANTY RETURNS

All returned service items whether under warranty or not, must be freight pre-paid and accompany a return authorization (R.A.) number. The R.A. number must be clearly written on the outside of the return package. A brief description of the problem as well as the R.A. number must also be written down on a piece of paper and included in the shipping container. If the unit is under warranty, you must provide a copy of your proof of purchase invoice. Items returned without a R.A. number clearly marked on the outside of the package will be refused and returned at customer's expense. You may obtain a R.A. number by contacting customer support.

SAFETY GUIDELINES

This fixture is a sophisticated piece of electronic equipment. To guarantee a smooth operation, it is important to follow all instructions and guidelines in this manual. Elation Professional is not responsible for injury and/or damages resulting from the misuse of this fixture due to the disregard of the information printed in this manual. Only qualified and/or certified personnel should perform installation of this fixture and only the original rigging parts (omega brackets) included with this fixture should be used for installation. Any modifications to the fixture and/or the included mounting hardware will void the original manufactures warranty and increase the risk of damage and/or personal injury.



PROTECTION CLASS 1 - FIXTURE MUST BE PROPERLY GROUNDED



THERE ARE NO USER SERVICEABLE PARTS INSIDE THIS UNIT. DO NOT ATTEMPT ANY REPAIRS YOURSELF; DOING SO WILL VOID YOUR MANUFACTURES WARRANTY. DAMAGES RESULTING FROM MODIFICATIONS TO THIS FIXTURE AND/OR THE DISREGARD OF SAFETY INSTRUCTIONS AND GUIDELINES IN THIS MANUAL VOID THE MANUFACTURES WARRANTY AND ARE NOT SUBJECT TO ANY WARRANTY CLAIMS AND/OR REPAIRS.



**DO NOT PLUG FIXTURE INTO A DIMMER PACK!
NEVER OPEN THIS FIXTURE WHILE IN USE!
UNPLUG POWER BEFORE SERVICING FIXTURE!
NEVER TOUCH FIXTURE DURING OPERATION, AS IT MAY BE HOT!
KEEP FLAMMABLE MATERIALS AWAY FROM FIXTURE!**



**NEVER LOOK DIRECTLY INTO THE LIGHT SOURCE!
RETINA INJURY RISK - MAY INDUCE BLINDNESS!
SENSITIVE PERSONS MAY SUFFER AN EPILEPTIC SHOCK!**



**INDOOR / DRY LOCATIONS USE ONLY!
DO NOT EXPOSE FIXTURE TO RAIN AND MOISTURE!**

SAFETY GUIDELINES

DO NOT TOUCH the fixture housing during operation. Turn OFF the power and allow approximately 15 minutes for the fixture to cool down before serving.

DO NOT shake fixture, avoid brute force when installing and/or operating fixture.

DO NOT operate fixture if the power cord is frayed, crimped, damaged and/or if any of the power cord connectors are damaged and do not insert into the fixture securely with ease.

NEVER force a power cord connector into the fixture. If the power cord or any of its connectors are damaged, replace it immediately with a new one of similar power rating.

DO NOT block any air ventilation slots.

All fan and air inlets must remain clean and never blocked.

Allow approx. 6" (15cm) between fixture and other devices or a wall for proper cooling.

When installing fixture in a suspended environment, always use mounting hardware that is no less than M10 x 25 mm, and always install fixture with an appropriately rated safety cable.

Always disconnect fixture from main power source before performing any type of service and/or cleaning procedure. Only handle the power cord by the plug end, never pull out the plug by tugging the wire portion of the cord.

During the initial operation of this fixture, a light smoke or smell may emit from the interior of the fixture. This is a normal process and is caused by excess paint in the interior of the casing burning off from the heat associated with the lamp and will decrease gradually over time.

Consistent operational breaks will ensure fixture will function properly for many years.

MAINTENANCE GUIDELINES



DISCONNECT POWER BEFORE PERFORMING ANY MAINTENANCE!

CLEANING

Frequent cleaning is recommended to insure proper function, optimized light output, and an extended life. The frequency of cleaning depends on the environment in which the fixture operates: damp, smoky or particularly dirty environments can cause greater accumulation of dirt on the fixture's optics. Clean the external lens surface at least every 20 days with a soft cloth to avoid dirt/debris accumulation.

NEVER use alcohol, solvents, or ammonia-based cleaners.

MAINTENANCE

Regular inspections are recommended to insure proper function and extended life.

There are no user serviceable parts inside this fixture, please refer all other service issues to an authorized Elation service technician. Should you need any spare parts, please order genuine parts from your local Elation dealer.

Please refer to the following points during routine inspections:

A detailed electric check by an approved electrical engineer every three months, to make sure the circuit contacts are in good condition and prevent overheating.

Be sure all screws and fasteners are securely tightened at all times. Loose screws may fall out during normal operation resulting in damage or injury as larger parts could fall.

Check for any deformations on the housing, color lenses, rigging hardware and rigging points (ceiling, suspension, trussing). Deformations in the housing could allow for dust to enter into the fixture. Damaged rigging points or unsecured rigging could cause the fixture to fall and seriously injure a person(s).

Electric power supply cables must not show any damage, material fatigue or sediments.

NEVER remove the ground prong from the power cable.

FIXTURE OVERVIEW

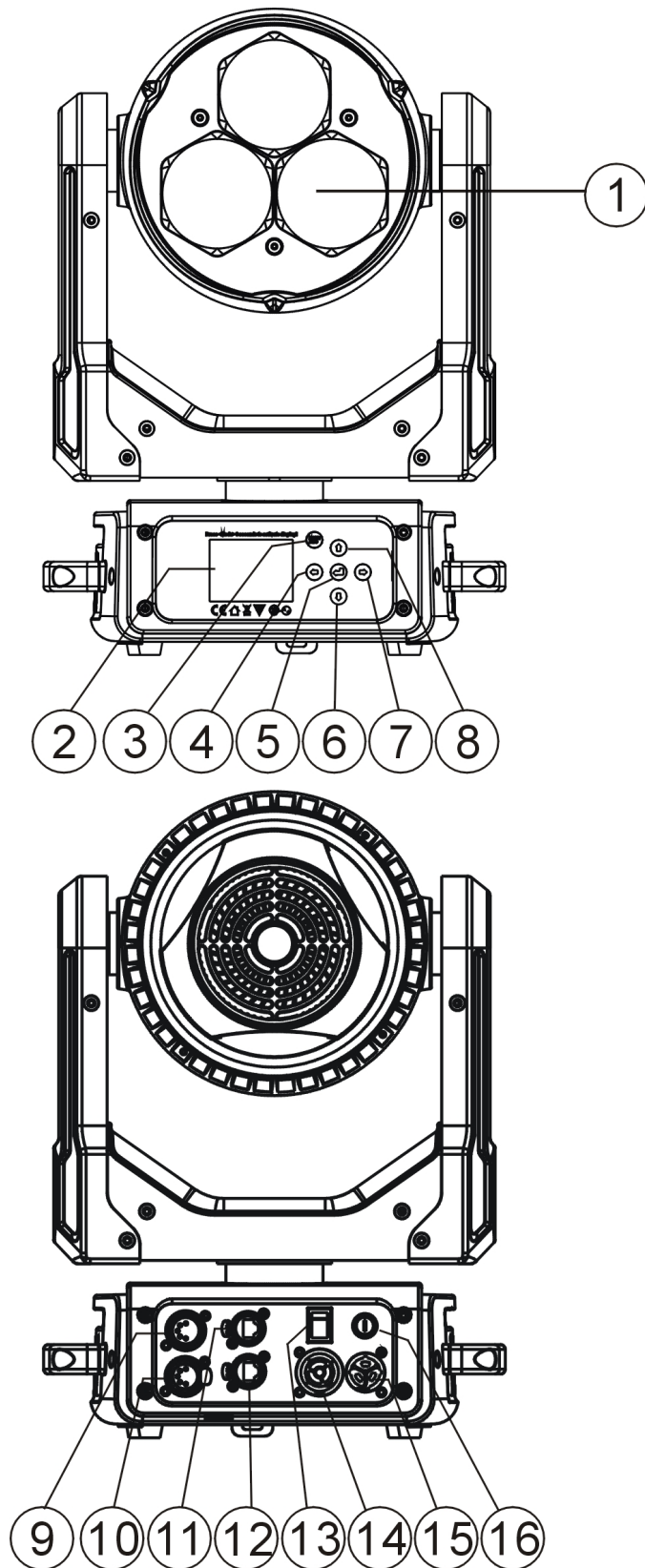

1. LED Lens Array
2. LCD Menu Function Display
3. MODE/ESC Button
4. ENTER Button
5. LEFT Button
6. DOWN Button
7. RIGHT Button
8. UP Button
9. 5pin DMX IN
10. 5pin DMX OUT
11. RJ45 Ethernet IN
12. RJ45 Ethernet OUT
13. Power Switch
14. Power OUT
15. Power IN
16. Fuse

INSTALLATION GUIDELINES



FLAMMABLE MATERIAL WARNING

Keep fixture minimum 5.0 feet (1.5m) away from flammable materials and/or pyrotechnics.



ELECTRICAL CONNECTIONS

A qualified electrician should be used for all electrical connections and/or installations.



USE CAUTION WHEN POWER LINKING OTHER MODEL FIXTURES AS THE POWER CONSUMPTION OF OTHER MODEL FIXTURES MAY EXCEED THE MAX POWER OUTPUT ON THIS FIXTURE. CHECK SILK SCREEN FOR AMX AMPS.



DO NOT INSTALL THE FIXTURE IF YOU ARE NOT QUALIFIED TO DO SO!

Fixture **MUST** be installed following all local, national, and country commercial electrical and construction codes and regulations.

Before rigging/mounting a single fixture or multiple fixtures to any metal truss/structure or placing the fixture(s) on any surface, a professional equipment installer **MUST** be consulted to determine if the metal truss/structure or surface is properly certified to safely hold the combined weight of the fixture(s), clamps, cables, and accessories.

Fixture ambient operating temperature range is **14° to 113°F. (-10° to 45°C)**
Do not use the fixture under or above this temperature.

Fixture(s) should be installed in areas outside walking paths, seating areas, or away from areas where unauthorized personnel might reach the fixture by hand.

NEVER stand directly below the fixture(s) when rigging, removing or servicing.
Overhead fixture installation must always be secured with a secondary safety attachment, such as an appropriately rated safety cable.

Allow approximately 15 minutes for the fixture to cool down before serving.

INSTALLATION GUIDELINES

OMEGA BRACKET INSTALLATION

Insert the Omega Bracket into the matching holes on the bottom of the fixture. Secure the Omega Bracket to the fixture by turning each quick-lock fastener ¼ turn clockwise; making sure the fastener is completely locked.

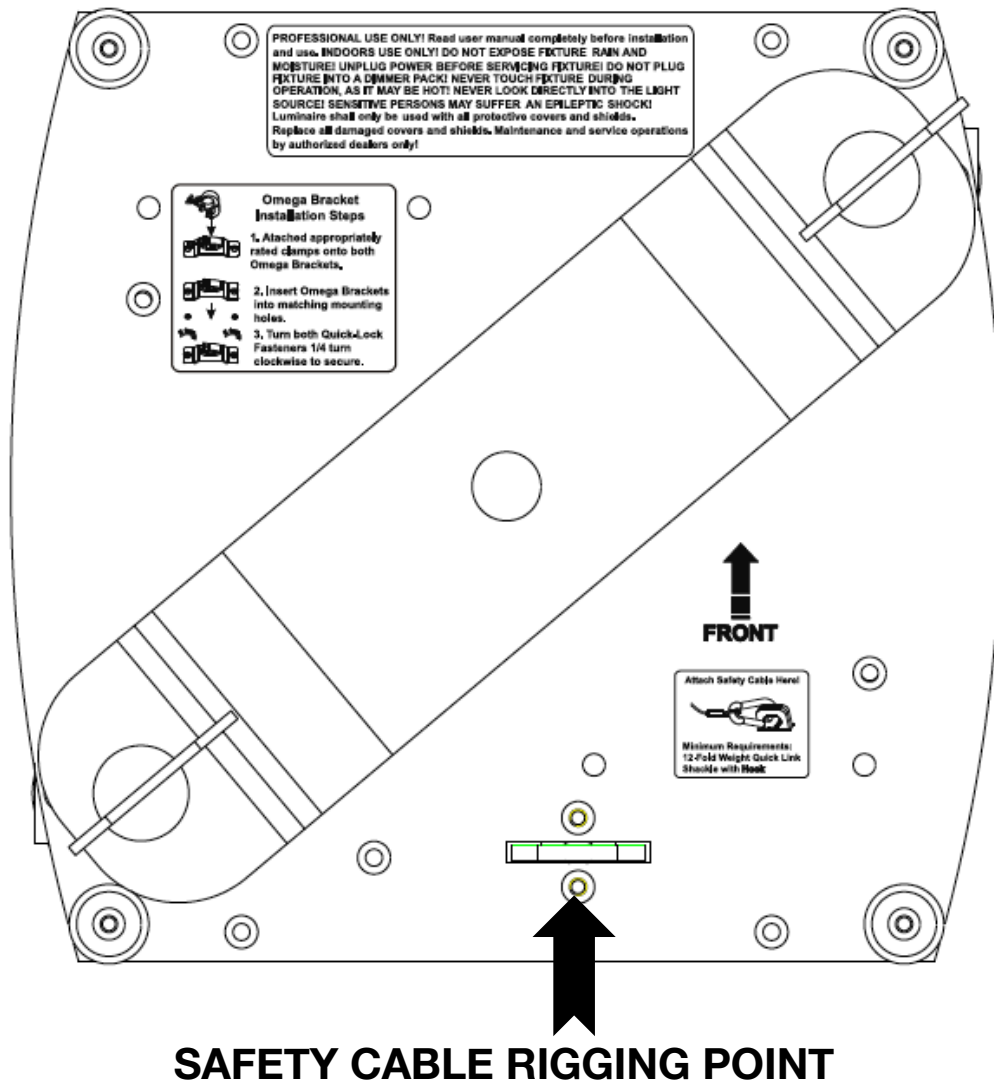

RIGGING

Overhead rigging requires extensive experience, including amongst others calculating working load limits, installation material being used, and periodic safety inspection of all installation material and the fixture. If you lack these qualifications, do not attempt the installation yourself. Improper installation can result in bodily injury

INSTALLATION GUIDELINES

CLAMP INSTALLATION

When mounting fixture to truss, be sure to secure an appropriately rated professional grade rigging clamp to the included **Omega Bracket** using an M10 screw fitted through the center hole of the **Omega Bracket**. The fixture provides a built-in rigging point for a **SAFETY CABLE**. Be sure to only use the designated rigging point for the safety cable and never secure a safety cable to a carrying handle.



ALWAYS ATTACH AN APPROPRIATELY RATED SAFETY CABLE (NOT INCLUDED) THAT MEETS ALL LOCAL, NATIONAL, AND COUNTRY CODES AND REGULATIONS WHENEVER INSTALLING FIXTURE IN A SUSPENDED ENVIRONMENT!

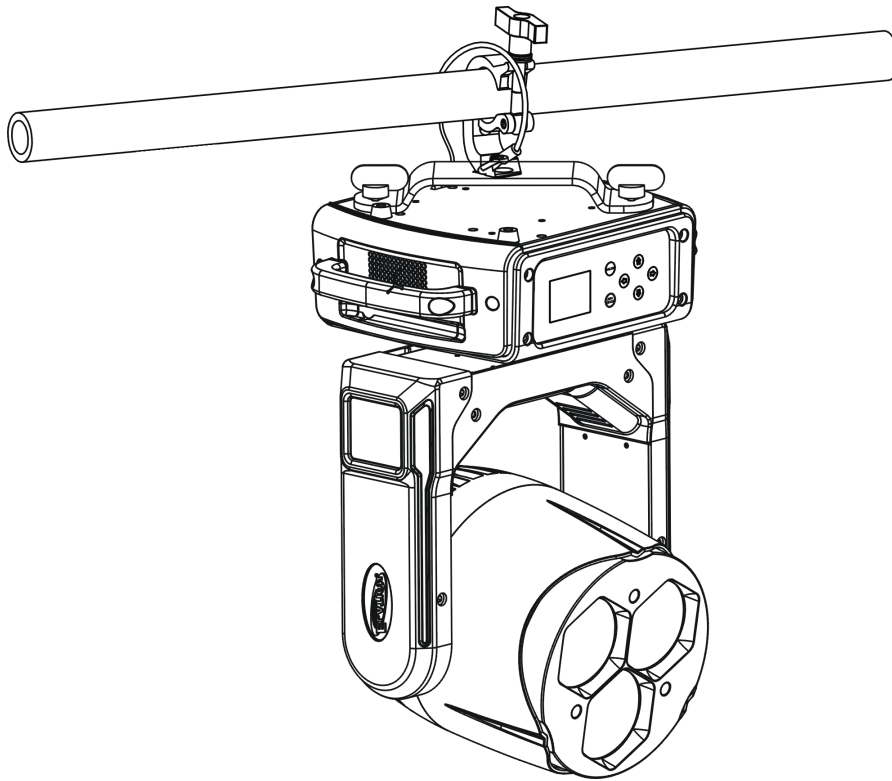

POWER LINKING



USE CAUTION WHEN POWER LINKING OTHER MODEL FIXTURES AS THE POWER CONSUMPTION OF OTHER MODEL FIXTURES MAY EXCEED THE MAX POWER OUTPUT ON THIS FIXTURE. CHECK SILK SCREEN FOR MAX AMPS.

KLING-NET / ART-NET CONNECTION

When connecting fixture to a network switch to control multiple devices, a **Gigabit Ethernet Switch** that supports **IGMP (Internet Group Management Protocol)** is required. Using a **Gigabit Ethernet Switch** that does not support **IGMP** can cause erratic behavior of all connected devices to the switch. Click link below for more information about IGMP. https://en.wikipedia.org/wiki/Internet_Group_Management_Protocol

INSTALLATION GUIDELINES

POTENTIAL INTERNAL FIXTURE DAMAGE FROM EXTERNAL SOURCES OF LIGHT BEAMS

External sources of light beams from direct sunlight, lighting moving head fixtures, and lasers, which are focused directly towards the exterior housing and/or penetrate the front lens opening of ELATION lighting fixtures, can cause severe internal damage including burning to optics, dichroic color filters, glass and metal gobos, prisms, animation wheels, frost filters, iris, shutters, motors, belts, wiring, discharge lamps, and LEDs.

This issue is not specific only to ELATION lighting fixtures, it is a common issue with lighting fixtures from all manufacturers. Although there is no true way to fully prevent this issue from happening, the guidelines below can prevent any potential damage from occurring if followed. Contact ELATION Service for more details.

DO NOT EXPOSE THE FIXTURE AND/OR FRONT LENS OPENING TO LIGHT BEAMS FROM DIRECT SUNLIGHT, OTHER LIGHTING MOVING HEAD FIXTURES, AND LASERS WHILE UNPACKING, INSTALLATION, USE, AND EXTENDED IDLE TIMES OUTDOORS.
DO NOT FOCUS A LIGHT BEAM FROM ONE LIGHTING FIXTURE DIRECTLY TOWARDS ANOTHER.

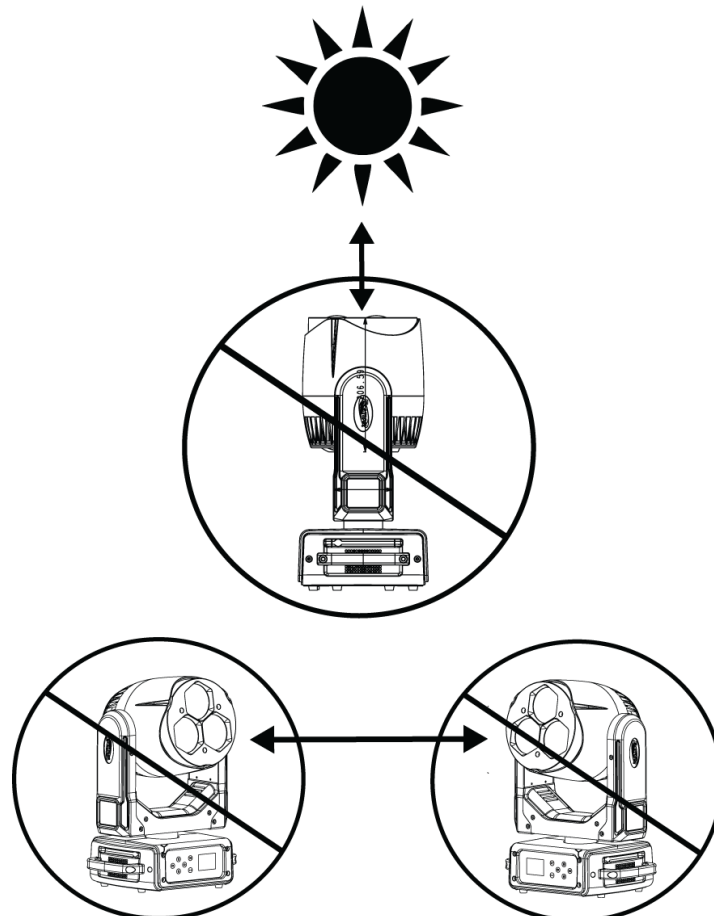

SYSTEM MENU

The fixture includes an easy to navigate system menu. The control panel (see image below) located on the front of the fixture, provides access to the main system menu and is where all necessary system adjustments are made to the fixture. During normal operation, pressing **MODE/ESC** button once will access the fixture's main menu. Once in the main menu you can navigate through the different functions and access the sub-menus with the **UP, DOWN, RIGHT, and LEFT** buttons. Once you reach a field that requires adjusting, press the **ENTER** button to activate that field and use the **UP** and **DOWN** buttons to adjust the field. Pressing the **ENTER** button once more will confirm your setting. You may exit the main menu at any time without making any adjustments by pressing the **MODE/ESC** button.

To access the LCD Menu Control Display via the internal battery, press and hold the **MODE/ESC** button for 3 seconds. The LCD Menu Control Display will shut **OFF** automatically about 1 minute from the last button press.

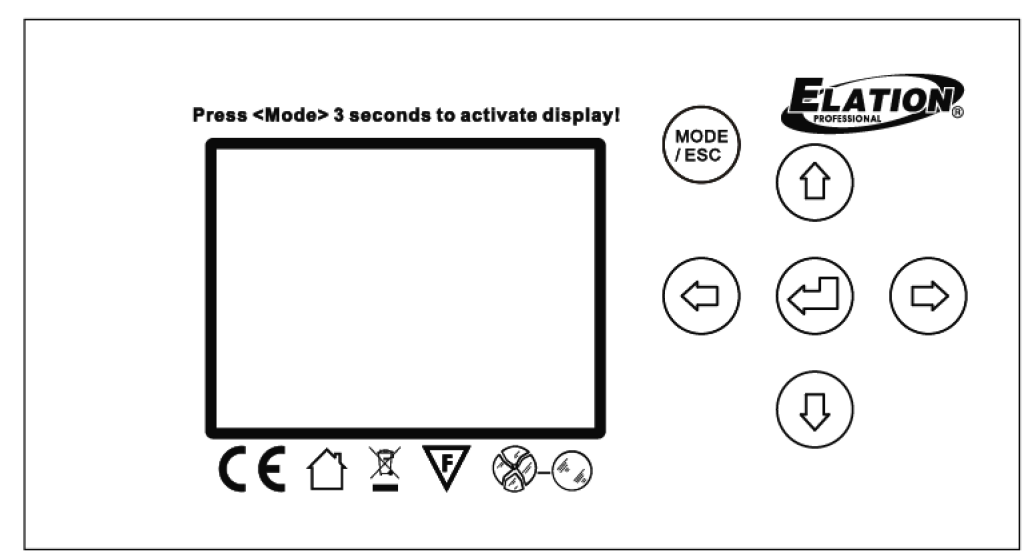

ELATION RAYZOR 360Z SYSTEM MENU

Features are subject to change without any prior written notice.

Supports Software Versions: ≥ 2.0.8

MAIN MENU	SUB MENU	OPTIONS / VALUES (Default Settings in BOLD)			
FUNCTION	Set DMxX Address	001~xxx		DMX Address Setting	
	DMx Value	ALL.....		DMX Value Display	
	Secondary Mode	Secondary1, Secondary2, Secondary3		Secondary Setting	
	Auto Program	Primary / Alone		Auto Program	
INFORMATION	Time Information	Current Time	XXXX (Hours)	Fixture Run Time From Power ON	
		Total Run Time	XXXX (Hours)	Fixture Total Run Time	
		Last Run Time	XXXX (Hours)	Clear Fixture Last Run Time	
		LastRun Password	Password=XXX	Password 038	
		Clear Last Run	ON / OFF	Reset Fixture Last Run Time	
	Temperature Info	Head Temperature	XXX C° / F°	Temperature in Fixture Head	
	Ethernet IP	XXX . XXX . XXX . XXX	XXX . XXX . XXX . XXX	IP Address	
	Fan Speed	FAN1:xxx RPM		Displays Fan Speed RPM	
	Software Version	1U01: - 3U01: Vx.x.x		Software Versions	
Error Info	Error Record 1 ~ Error Record 10		Displays Last 10 Error Codes		
PERSONALITY	Status Settings	Address via DMX	ON/OFF	Address Via DMX	
		No DMX Status	Hold/Close Shutter/ Auto Program	Auto Run If No DMX	
		Pan Reverse	ON/OFF	Pan Reverse Movement	
		Tilt Reverse	ON/OFF	Tilt Reverse Movement	
		Pan Degree	630/ 540	Pan Degree Select	
		Feedback	ON/OFF	Movement Feedback	
		Hibernation	OFF, 01M~99M, 15M	Stand By Mode	
	Service Setting	Password	Password= 050		Service Password
		RDM PID	XXXXX		RDM PID Code
		Ethernet IP	XXX . XXX . XXX . XXX		Ethernet IP
		Ethernet Mask IP	XXX . XXX . XXX . XXX		Ethernet Mask IP
		Clear Err. Info	ON/OFF		Clear Error Code History
	Fans Control	Auto , Low, High		Set Fan Speed	
	Display Setting	Shutoff Time	02~60m 05m	Display Shut Off Time	
		Flip Display	ON/OFF	Flip/Invert Display 180°	
		Key Lock	ON/OFF	Key Lock	
		Disp Flash	ON/OFF	Display Flashes When No DMX Signal	
	Temperature C/F	Celsius/Fahrenheit		Temperature Switch Between C°/ F°	
	Initial Status	PAN =XXX		Initial Effect Position	
	Dimmer Modes	Standard , Stage, TV, Architectural, Theatre			
	Select Signal	DMX Only		DMX Only	
		Art-Net on IP2		Elect Art-Net IP02	
		Art-Net on IP10		Elect Art-Net IP010	
		sACN		sACN Protocol	
	Set Universe	000 - 255		Set Art-Net Universe	
	Refresh	1200 , 900-1500, 2500, 4000, 5000, 10000, 15000, 20000, 25000 (Hz)		Set Refresh Rate	
	Gamma	2.0, 2.2 , 2.4, 2.6, 2.8		Set Gamma Value	
Reset Default	ON/OFF	Password 011	Restore Factory Settings NOTE: Saved White Balance Erased!		

ELATION RAYZOR 360Z SYSTEM MENU

Features are subject to change without any prior written notice.

Supports Software Versions: ≥ 2.0.8

MAIN MENU	SUB MENU	OPTIONS / VALUES (Default Settings in BOLD)		DESCRIPTION
Reset Function	Reset All			Reset All Motors
	Reset Pan&Tilt			Reset Pan/Tilt
	Reset Zoom			Reset Zoom
Effect Adjust	Test Channel	PAN		Test function
	Manual Control	PAN =XXX,		Fine Adjustments
	Calibration	Calibration Password		Password 050
User Mode Set	User Mode	Standard Mode		DMX Channel Modes
		Basic Mode		
		Extended Mode		
		User Mode A		User Defined Channel Assignment
		User Mode B		
		User Mode C		
	Edit User Mode	Edit User Mode A	Max Channel = XX	Edits User Defined Channel Assignments
Edit User Mode B		PAN = CH01		
Edit User Mode C				
Edit Program	Select Program	Auto Pro Part1 = Program 1~10 (Program 1)		Select Programs To Be Run
		Auto Pro Part2 = Program 1~10 (Program 2)		
		Auto Pro Part3 = Program 1~10 (Program 3)		
	Edit Program	Program 1	Program Test	Testing Program
		:	Step 01=SCxxx	Program In Loop
		Program 10	Step 64=SCxxx	Save and Exit
	Edit Scenes	Scene 001 ~ Scene 250	Pan,Tilt,.....	Save and Automatically Return
			--Fade Time-- --Scene Time--	Manual Scenes Edit
			Input By Outside	Stores Scenes via Ext DMX Console
	Rec. Controller	XX~XX		Automatic Scenes Recorder

SYSTEM MENU CHANGE WITH SOFTWARE UPDATE VERSION ≥2.0.8

See highlighted menu items below which have been updated with this software update

PERSONALITY	Service Setting	Password	Password= 050	Service Password
		RDM UID	XXXXX	RDM PID Code
		Clear Err. Info	ON/OFF	Clear Error Code History
	Select Signal	DMX Only		DMX Only
		Art-Net		Art-Net Protocol
		sACN		sACN Protocol
	Klingnet Setting	ON/OFF		Enable Kling-Net Protocol
	Ethernet IP	XXX . XXX . XXX . XXX		Enter Fixture Ethernet Address
	Ether Mask IP	XXX . XXX . XXX . XXX		Enter Fixture Subnet Mask Address
	Set Universe	000 - 32767		Set Art-Net Universe

PERSONALITY - Status Settings - Address Via DMX

When ON, define the desired DMX address via an external controller.

1. Connect the fixture to the external controller and power ON.
2. Set the DMX value of **Channel 1** on the controller to **(7)**.
3. Set the DMX value of **Channel 2** on the controller to **(7)** or **(8)**.
When set to **(7)**, the DMX address can be set between **(1)** and **(255)**.
When set to **(8)**, the DMX address can be set between **(256)** and **(511)**.
4. Using **Channel 3** on the controller set the desired DMX address of the fixture.

Example 1: If the desired DMX address is **57**, set **Channel 1** to a value of **(7)**, set **Channel 2** to a value of **(7)**, and then set **Channel 3** to a value of **(57)**.

Example 2: If the desired DMX address is **420**, set **Channel 1** to a value of **(7)**, set **Channel 2** to a value of **(8)**, and then set **Channel 3** to a value of **(164)**. ($256+164=420$)

5. After setting **Channel 3** to the desired DMX address value, wait for approximately 20 seconds for the fixture to complete the address reset function.

PERSONALITY – Service Setting - Password (050)

NOTE: The Service Password MUST be entered in order to access the following menus:

RDM PID, Ethernet IP, Ethernet IP Mask, and Clear Err. Info.

PERSONALITY – Service Setting - RDM PID

Select various submenus via RDM. RDM stands for "Remote Device Management", which provides the ability to control the device remotely while connected to a DMX-bus. ANSI E1.20-2006 by ESTA specifies the RDM standard as an extension of the DMX512 protocol. Manual settings like adjusting the DMX starting address are no longer needed. This is especially useful when the device is installed in a remote area.

RDM ready and conventional DMX devices can be operated in one DMX line. The RDM protocol sends its own packages in the DMX512 data feed and does not influence conventional devices. If DMX splitters are used and RDM control is to be used, these splitters must support RDM. The number and type of RDM parameters depend on the RDM controller being used.

PERSONALITY - Display Setting – Key Lock

When ON, Control Panel buttons lock automatically after exiting main menu for 15 seconds. To unlock, keep **MODE/ESC** button pressed for 3 seconds.

PERSONALITY - Dimming Modes

Select desired DIMMER MODE (**Standard**, Stage, TV, Architectural, Theatre).

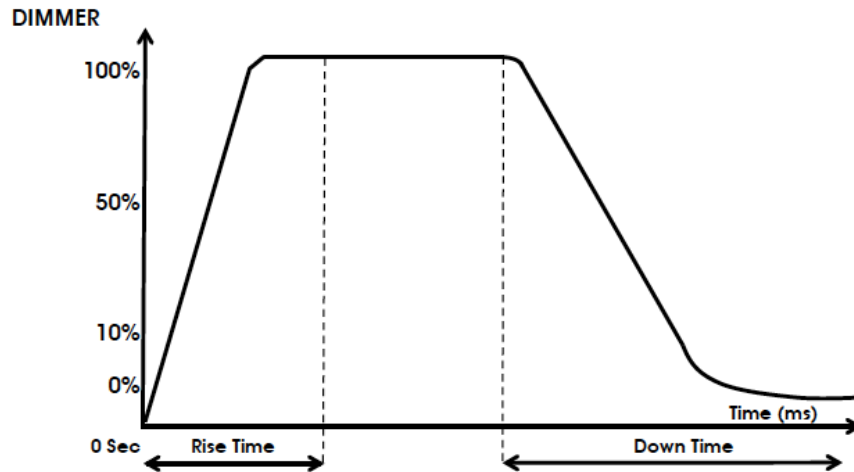

Dimming Curve Ramp Effect	0 sec Fade Time		1 sec Fade Time	
	Rise Time (ms)	Down Time (ms)	Rise Time (ms)	Down Time (ms)
Standard (default)	0	0	0	0
Stage	780	1100	1540	1660
TV	1180	1520	1860	1940
Architectural	1380	1730	2040	2120
Theatre	1580	1940	2230	2280

PERSONALITY - Reset Default (011)



ONLY QUALIFIED TECHNICIANS SHOULD PERFORM THIS FUNCTION.

NOTE: SAVED WHITE BALANCE IS ERASED AFTER A RESET IS PERFORMED.

This function restores all fixture settings to the factory default settings. The password is **011** and must be entered each time a reset is performed.

EFFECT ADJUST - Test Channel

Auto test each individual channel function independently from the DMX control board.

EFFECT ADJUST - Manual Control

Select and manually test and fine adjust each individual channel function Independently from DMX control board. This function will center PAN and TILT motors and set dimmer to 100%. PAN and TILT functions will still operate if the fixture needs to be positioned to a flat clear surface. With the individual functions, you can focus the light on a flat surface (wall) and perform fine adjustments.

EFFECT ADJUST – Calibration



ONLY QUALIFIED TECHNICIANS SHOULD PERFORM THIS FUNCTION.

This function allows small adjustments to be made to the Pan, Tilt, and Zoom movements to compensate for wear or in the event a sensor has been knocked slightly out of place. Because improper use of this function can result in undesired operation this function has been password protected. The password is **050** and must be entered each time the calibration menu function is entered. Because calibration is an extremely delicate procedure, instructions on performing this action are left out of this manual. For a first time calibrator, please contact our customer support team for step-by-step instructions.

USER MODE SET – Edit User Mode

Create user defined channel orders allowing the fixture to match the channel order of other fixtures on the market for easier operation. A total of three user modes may be configured: User Mode A, User Mode B, and User Mode C.

EDIT PROGRAM – Rec. Controller

The fixture features an integrated DMX-recorder by which you can transmit the programmed scenes from your DMX-controller to the moving head. Adjust the desired scene numbers via the encoder (from – to). When you call up the scenes at your controller, they will automatically be transmitted to the moving head.

EDIT PROGRAM – Record Controller – Working With Built In Programs

A Primary unit can send up to 3 different data groups to the Secondary units, i.e. a Primary unit can start 3 different Secondary units, which run 3 different programs. The Primary unit sends the 3 program parts in a continuous loop.



The Secondary unit receives data from the Primary unit according to the group which the Secondary unit was assigned to. If e.g. a Secondary unit is set to “**Secondary 1**” in the menu “**Set to Secondary**”, the Primary unit sends “**Auto Program Part 1**” to the Secondary unit. If set to “**Secondary 2**”, the Secondary unit receives “**Auto Program Part 2**”.

EDIT PROGRAM – Record Controller – Working With Built-In Program [continued]

To start an Auto Program proceed as follows:

1. Secondary Setting

- Select **“Function Mode”**.
- Press **ENTER** to confirm.
- Select **“Set to Secondary”**.
- Press **ENTER** to confirm.
- Select **“Secondary 1”**, **“Secondary 2”** or **“Secondary 3”**.
- Press **ENTER** to confirm.
- Press **MODE/ESC** in order to return to the main menu.

2. Automatic Program Run

- Select **“Function Mode”**.
- Press **ENTER** to confirm.
- Select **“Auto Program”**.
- Press **ENTER** to confirm.
- Select **“Primary”** or **“Alone”**.
- Press **ENTER** to confirm.
- Press **MODE/ESC** in order to return to the main menu.

3. Program Selection for Auto Pro Part

- Select **“Edit Program”**.
- Press **ENTER** to confirm.
- Select **“Select Programs”**.
- Press **ENTER** to confirm.
- Select **“Auto Pro Part 1”**, **“Auto Pro Part 2”** or **“Auto Pro Part 3”**, and select which Secondary program is to be sent. Selection **“Part 1”** means, that the Secondary unit runs the same program as the Primary units.
- Press **ENTER** to confirm.
- Press **MODE/ESC** in order to return to the main menu.

EDIT PROGRAM – Record Controller – Working With Built-In Program [continued]

4. Program Selection for Edit Program

- Select “**Edit Program**”.
- Press **ENTER** to confirm.
- Select “**Edit Program**”.
- Press **ENTER** to confirm.
- Select the desired program to edit specific scenes into a specific program.
- Press **ENTER** to confirm.
- Press **MODE/ESC** in order to return to the main menu.

5. Automatic Scene Recording

- Select “**Edit Program**”.
- Press **ENTER** to confirm.
- Select “**Edit Scenes**”.
- Select desired scene numbers. A maximum of 250 scenes can be programmed.
- Press **ENTER** to confirm.
- Press **MODE/ESC** in order to return to the main menu.

Example:

Program 2 includes scenes: 10, 11, 12, & 13

Program 4 includes scenes: 8, 9, & 10

Program 6 includes scenes: 12, 13, 14, & 15

Auto Pro Part 1 is Program 2

Auto Pro Part 2 is Program 3

Auto Pro Part 3 is Program 6

The 3 Secondary groups run the Auto Program in certain time segments. (See diagram below)

Part 1:

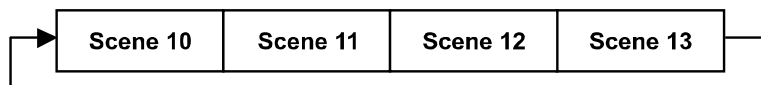

Part 2:

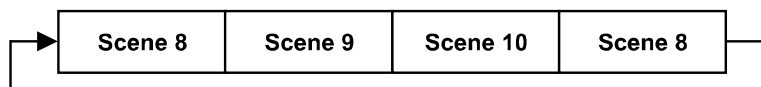

Part 3:

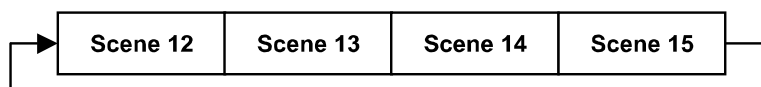

WHITE BALANCE SETTING

This feature provides the ability to individually adjust the maximum dimmer intensity for each LED color (Red, Green, Blue, White, Amber, Cyan, U.V.) and store these values as a White Balance preset. This can be a useful tool when the output intensity of a group of same model fixtures with varying usage times, needs to be calibrated to match as much as possible. Once a new White Balance preset is saved to the fixture, the maximum dimmer intensity values cannot be changed until the White Balance preset is updated, erased or restored to the factory default setting.

1. Set ALL DMX channels to zero (0) then set the **SPECIAL FUNCTIONS** channel (CH20 in Basic Mode, CH26 in Stand Mode, CH32 in Extend Mode) to DMX value of (91-93) **EDIT and SAVE WHITE BALANCE ENABLED.**
2. Set the **COLOR MODE - WHITE BALANCE** channel (CH18 in Basic Mode, CH24 in Stand Mode, CH30 in Extend Mode) to DMX value of (190-254) **EDIT and SAVE WHITE BALANCE Setting.**
3. Adjust each LED color channel to the desired intensity level (0-255).
4. Set the **COLOR MODE - WHITE BALANCE** channel (CH18 in Basic Mode, CH24 in Stand Mode, CH30 in Extend Mode) to DMX value of (255) **SAVE New WHITE BALANCE Setting** to Fixture(s).
5. To save a new White Balance preset, repeat steps 1-4 above.

DMX CHANNEL FUNCTIONS AND VALUES

ELATION RAYZOR 360Z				
DMX Channel Values / Functions (32 DMX Channels)				
Supports Software Versions: $\geq 2.0.8$				
Features are subject to change without any prior written notice.				
*Rotation direction (Clockwise or Counterclockwise) of effects depends on orientation of the fixture head and Pan/Tilt settings.				
MODE / CHANNEL			VALUE	FUNCTION
BASIC	STAND	EXTEND		
1	1	1		PAN MOVEMENT [8 BIT]
			0-255	PAN Movement
	2	2		PAN FINE MOVEMENT [16 BIT]
			0-255	Fine Control of PAN Movement
2	3	3		TILT MOVEMENT [8 BIT]
			0-255	TILT Movement
	4	4		TILT MOVEMENT [16 BIT]
			0-255	Fine Control of TILT Movement
3	5	5		PAN CONTINUOUS MOVEMENT
			0-127	NO FUNCTION
			128-189	PAN Clockwise from FAST to SLOW
			190-193	NO Rotation
			194-255	PAN Counter-Clockwise from SLOW to FAST
4	6	6		TILT CONTINUOUS MOVEMENT
			0-127	NO FUNCTION
			128-189	TILT Clockwise from FAST to SLOW
			190-193	NO Rotation
			194-255	TILT Counter-Clockwise from SLOW to FAST
5	7			RED [ALL LEDs]
			0-255	Red (0-Black - 255-100%)
	8			RED FINE [ALL LEDs]
			0-255	Red FINE Adjustment
6	9			GREEN [ALL LEDs]
			0-255	Green (0-Black - 255-100%)
	10			GREEN FINE [ALL LEDs]
			0-255	Green FINE Adjustment
7	11			BLUE [ALL LEDs]
			0-255	Blue (0-Black - 255-100%)
	12			BLUE FINE [ALL LEDs]
			0-255	Blue FINE Adjustment
8	13			WHITE [ALL LEDs]
			0-255	White (0-Black - 255-100%)
	14			WHITE FINE [ALL LEDs]
			0-255	White FINE Adjustment

ELATION RAYZOR 360Z
DMX Channel Values / Functions (32 DMX Channels)

Supports Software Versions: ≥ 2.0.8

Features are subject to change without any prior written notice.

*Rotation direction (Clockwise or Counterclockwise) of effects depends on orientation of the fixture head and Pan/Tilt settings.

MODE / CHANNEL			VALUE	FUNCTION
BASIC	STAND	EXTEND		
		7		RED [LED 1]
			0-255	Red (0-Black - 255-100%)
		8		GREEN [LED 1]
			0-255	Green (0-Black - 255-100%)
		9		BLUE [LED 1]
			0-255	Blue (0-Black - 255-100%)
		10		WHITE [LED 1]
			0-255	White (0-Black - 255-100%)
		11		RED [LED 2]
			0-255	Red (0-Black - 255-100%)
		12		GREEN [LED 2]
			0-255	Green (0-Black - 255-100%)
		13		BLUE [LED 2]
			0-255	Blue (0-Black - 255-100%)
		14		WHITE [LED 2]
			0-255	White (0-Black - 255-100%)
		15		RED [LED 3]
			0-255	Red (0-Black - 255-100%)
		16		GREEN [LED 3]
			0-255	Green (0-Black - 255-100%)
		17		BLUE [LED 3]
			0-255	Blue (0-Black - 255-100%)
		18		WHITE [LED 3]
			0-255	White (0-Black - 255-100%)
9	15	19		COLOR MACROS
			0-7	NO FUNCTION
			8-39	From RED to YELLOW
			40-71	From YELLOW to GREEN
			72-103	From GREEN to CYAN
			104-135	From CYAN to BLUE
			136-167	From BLUE to MAGENA
			168-199	From MAGENTA to RED
			200-231	From RED to WHITE
232-255	Crossfading Colors from SLOW to FAST			
10	16	20		COLOR PRESETS
			0-9	NO FUNCTION
			10-50	WHITE 2700K
			51-91	WHITE 3200K
			92-132	WHITE 4300K
			133-173	WHITE 5600K
			174-214	WHITE 6500K
215-255	WHITE 8000K			
11	17	21		COLOR PRESETS DIMMER
			0-255	Dimmer 100 to 0%

ELATION RAYZOR 360Z
DMX Channel Values / Functions (32 DMX Channels)

Supports Software Versions: ≥ 2.0.8

Features are subject to change without any prior written notice.

*Rotation direction (Clockwise or Counterclockwise) of effects depends on orientation of the fixture head and Pan/Tilt settings.

MODE / CHANNEL			VALUE	FUNCTION
BASIC	STAND	EXTEND		
12	18	22		SHUTTER, STROBE
			0-31	Shutter CLOSED (LEDs OFF)
			32-63	Shutter OPEN (LEDs ON)
			64-95	Strobe Effect SLOW to FAST
			96-127	Shutter OPEN (LEDs ON)
			128-159	Pulse Effect In Sequences
			160-191	Shutter OPEN (LEDs ON)
			192-223	Random Strobe Effect SLOW to FAST
		224-255	Shutter OPEN (LEDs ON)	
13	19	23		DIMMER INTENSITY
			0-255	Dimmer 0 to 100%
		24		DIMMER INTENSITY FINE
			0-255	Dimmer FINE Adjustment
14	20	25		DIMMER MODES
			0-20	Standard
			21-40	Stage
			41-60	TV
			61-80	Architectural
			81-100	Theatre
		101-255	Default to Setting on Fixture	
15	21	26		MOTORIZED ZOOM
			0-255	ZOOM Adjustment from SMALL to BIG
		27		MOTORIZED ZOOM FINE
			0-255	ZOOM FINE Adjustment
16	22	28		CHASE PATTERNS
			0-10	NO FUNCTION (LEDs OFF)
			11-40	Chase 1
			41-70	Chase 2
			71-100	Chase 3
			101-130	Chase 4
			131-160	Chase 5
			161-190	Chase 6
			191-220	Chase 7
		221-255	Chase 8	
17	23	29		CHASE PATTERN SPEED
			0-255	*Counterclockwise Chase Speed FAST to SLOW
18	24	30		COLOR MODE - WHITE BALANCE
			0-189	NO FUNCTION
			190-254	EDIT a New WHITE BALANCE Setting
			255	SAVE New WHITE BALANCE Setting to Fixture(s)
			*NOTE: DMX VALUE of 91-93 MUST FIRST BE SELECTED ON CH20 (Basic), CH26 (Stand), or CH32 (Extend) TO ENABLE FEATURE.	
19	25	31		PAN / TILT MOVEMENT SPEED
			0-225	MAX to MIN Speed
			226-235	Blackout by Movement
			236-255	NO FUNCTION

ELATION® RAYZOR 360Z™
DMX Channel Values / Functions (32 DMX Channels)

Supports Software Versions: ≥ 2.0.8

Features are subject to change without any prior written notice.

*Rotation direction (Clockwise or Counterclockwise) of effects depends on orientation of the fixture head and Pan/Tilt settings.

MODE / CHANNEL			VALUE	FUNCTION
BASIC	STAND	EXTEND		
20	26	32		SPECIAL FUNCTIONS / INTERNAL PROGRAMS
			0-79	Color Change Normal
			80-84	ALL MOTOR RESET
			85-87	SCAN MOTOR RESET
			88-90	NO FUNCTION
			91-93	EDIT and SAVE WHITE BALANCE ENABLED
			94-96	NO FUNCTION
			97-99	OTHER MOTORS RESET
			100-119	Internal Program 1 (Scene 1-8)
			120-139	Internal Program 2 (Scene 9-16)
			140-159	Internal Program 3 (Scene 17-24)
			160-179	Internal Program 4 (Scene 25-32)
			180-199	Internal Program 5 (Scene 33-40)
			200-219	Internal Program 6 (Scene 41-48)
			220-239	Internal Program 7 (Scene 49-56)
			240-255	NO FUNCTION

LED PIXEL CONTROL

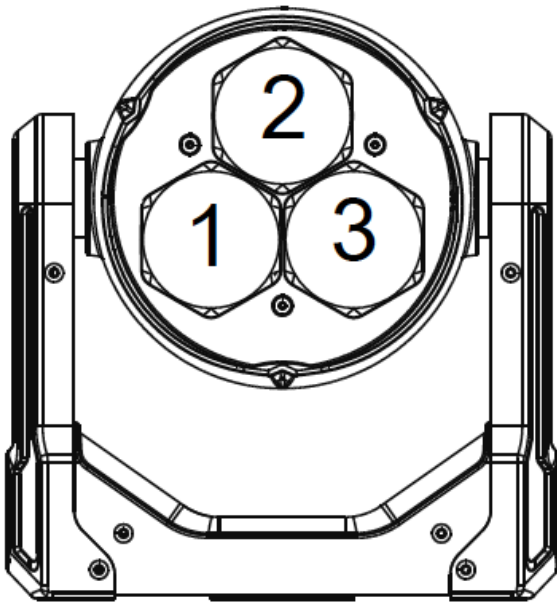

LCD CONTROL DISPLAY

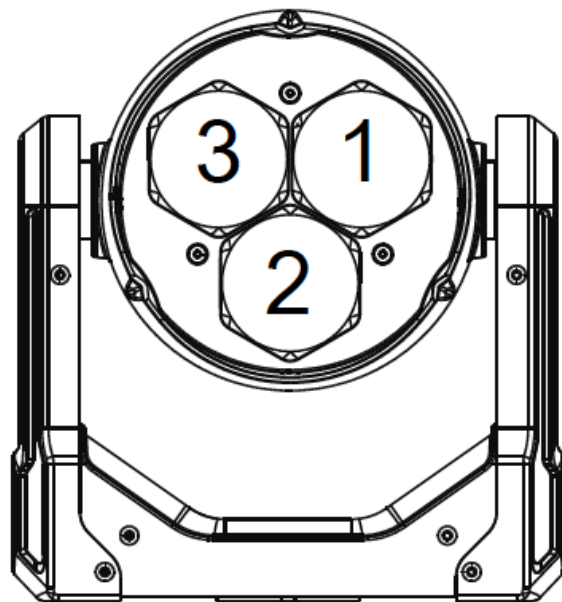

LCD CONTROL DISPLAY



Pixel control depends on PAN/TILT position of head.

ERROR CODES

When power is applied, the unit will automatically enter a **“Reset/Test”** mode. This mode brings all the internal motors to a home position. If there is an internal problem with one or more of the motors an error code will flash in the display in the form of **“XXer”** where as XX will represent a function number. For example, when the display shows **“0Er”** it means there is some type of error with the Pan motor. If there are multiple errors during the start-up process they will all flash in the display. For example: if the fixtures has errors on **Channel 1, 2, and 5** all at the same time, you will see the error message **“01Er”, “02Er”, and “05Er”** flash repeated 5 times.

If an error does occur during the initial start-up procedure the fixture will self-generate a second reset signal and try to realign all the motors and correct the errors. If the error persists after a second attempt a third attempt will be made. If after a third attempt all the errors have not been corrected the fixture will make the following determinations:

- **3 or More Errors** - The fixture cannot function properly with three or more errors therefore the fixture will place itself in a stand-by mode until subsequent repairs can be made.
- **Less Than 3 Errors** - The fixture has less than 3 errors; therefore, most other functions will work properly. The fixture will attempt to operate normally until the errors can be correct by a technician. The errors in question will remain flashing in the display as a reminder of internal errors.

Error Codes are subject to change without any prior written notice.	
ERROR CODES	DESCRIPTION
PAN Er	Movement is not located in the default position after the reset. This message will appear after a fixture reset if the magnetic-indexing circuit malfunctions (sensor failed, or magnet is missing) or there is a motor failure (defective motor or a defective motor IC drive on the main PCB). This error may also be displayed if the head/yoke was blocked during a reset function.
TILT Er	
Zoom Er	Movement is not located in the default position after the reset. This message will appear after a fixture reset if the magnetic-indexing circuit malfunctions (sensor failed, or magnet is missing) or there is a motor failure (defective motor or a defective motor IC drive on the main PCB).

SPECIFICATIONS

SOURCE

(3) 60W Osram™ RGBW LEDs
50,000 Hour Average LED Life*

*May vary depending on several factors including but not limited to: Environmental Conditions, Power/Voltage, Usage Patterns (On-Off Cycling), Control, and Dimming.

PHOTOMETRIC DATA

28,020 LUX 2,603 FC @6.6' (2m) (8° Min Zoom) Full ON

545 LUX 51 FC @6.6' (2m) (77° Max Zoom) Full ON

CRI 80

Zoom Range 8° - 77°

Beam Angle 4.6° - 56.8°

Field Angle 5.8° - 74.1°

EFFECTS

Motorized Zoom

Linear Color Temperature Presets (2,700 - 8,000K)

RGBW Color Mixing and Pixel Control

8 Color Presets and 8 Chase Macros

Electronic Strobe and Variable Dimming Curves

COLOR

RGBW

CONTROL / CONNECTIONS

(3) DMX Channel Modes (20 / 26 / 32)

360° Continuous Pan and Tilt Movement

Adjustable Refresh Rate (900-25,000 (Hz)

Adjustable Gamma Brightness (2.0, 2.2, 2.4, 2.8)

(6) Button Touch Control Panel

8 / 16 Bit Resolution Adjustable Movement

Full Color 180° Reversible LCD Menu Display

5pin XLR DMX In/Out

RDM (Remote Device Management)

RJ45 ethernet In/Out (Art-NET, sACN)

IP65 Locking Power Cable In/Out

With Wired Digital Communication Network

SIZE / WEIGHT

Length: 11.0" (280.6mm)

Width: 7.9" (199.5mm)

Vertical Height: 16.6" (422.1mm)

Weight: 17 lbs. (7.7 kg)

ELECTRICAL / THERMAL

AC 100-240V - 50/60Hz

300W Max Power Consumption

14°F to 113°F (-10°C to 45°C)

BTU/hr (+/- 10%) 930.93

APPROVALS / RATINGS

CE | IP20

Specifications and improvements in the design of this unit and this manual are subject to change without any prior written notice.

FCC STATEMENT

This device complies with Part 15 of the FCC Rules. Operation is subject to the following two conditions: (1) this device may not cause harmful interference, and (2) this device must accept any interference received, including interference that may cause undesired operation.

FCC RADIO FREQUENCY INTERFERENCE WARNINGS & INSTRUCTIONS

This product has been tested and found to comply with the limits as per Part 15 of the FCC Rules. These limits are designed to provide reasonable protection against harmful interference in a residential installation. This device uses and can radiate radio frequency energy and, if not installed and used in accordance with the included instructions, may cause harmful interference to radio communications. However, there is no guarantee that interference will not occur in a particular installation. If this device does cause harmful interference to radio or television reception, which can be determined by turning the device off and on, the user is encouraged to try to correct the interference by one or more of the following methods:

- Reorient or relocate the device.
- Increase the separation between the device and the receiver.
- Connect the device to an electrical outlet on a circuit different from which the radio receiver is connected.
- Consult the dealer or an experienced radio/TV technician for help.

Europe Energy Saving Notice

Energy Saving Matters (EuP 2009/125/EC)

Saving electric energy is a key to help protecting the environment. Please turn off all electrical products when they are not in use. To avoid power consumption in idle mode, disconnect all electrical equipment from power when not in use. Thank you.

DIMENSIONAL DRAWINGS

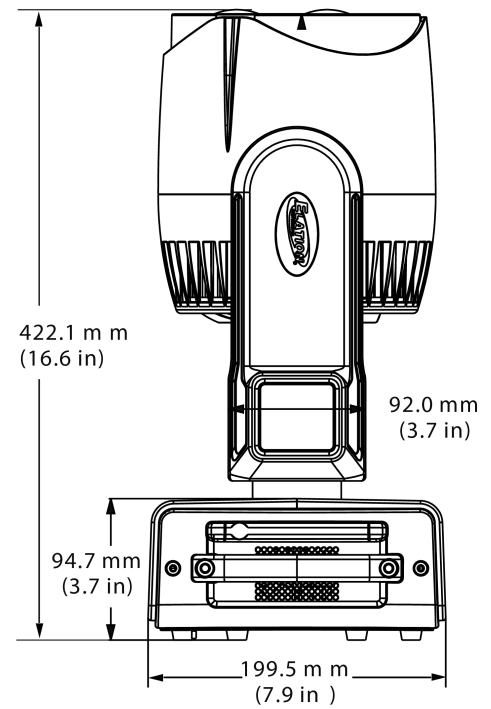
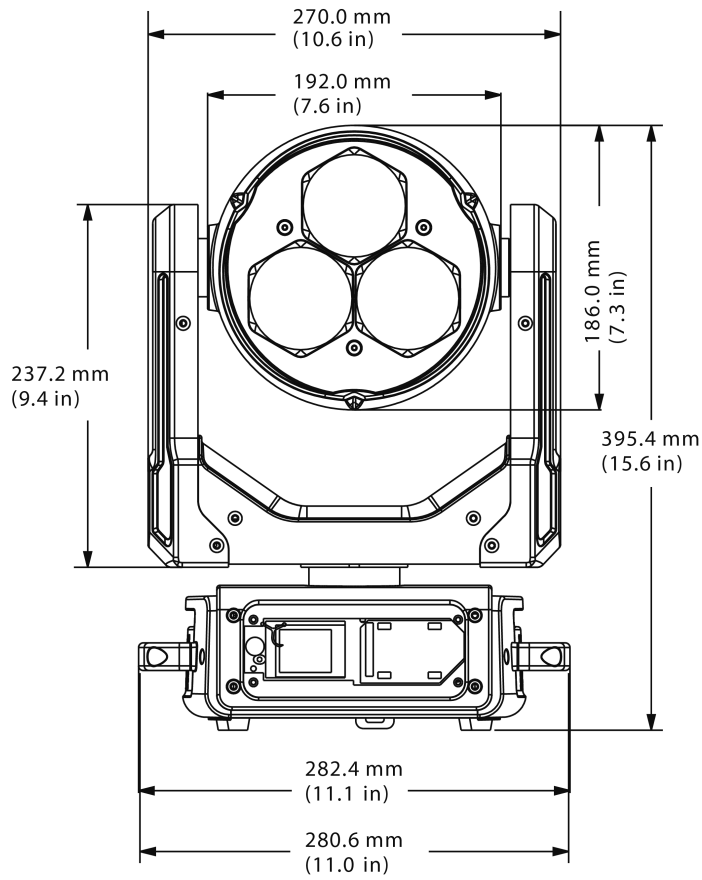

Specifications and improvements in the design of this unit and this manual are subject to change without any prior written notice.

OPTIONAL ACCESSORIES

ORDER CODE	ITEM
TRIGGER CLAMP	Heavy Duty Wrap Around Hook Style Clamp
DRCZ360Z	4-Pack Road Case For RAYZOR 360Z
AC5PDMX5PRO	5 ft. (1.5m) 5pin PRO DMX Cable
CAT6PRO5	5 ft. (1.5m) CAT6 Cable
NEU088	3 ft. (1m) Power Cable
	Additional Cable Lengths Available

