



CUEPIX 16IP DTW

Photometric Test Report

©2021 ELATION PROFESSIONAL all rights reserved. Information, specifications, diagrams, images, and instructions herein are subject to change without notice. ELATION PROFESSIONAL logo and identifying product names and numbers herein are trademarks of ELATION PROFESSIONAL. Copyright protection claimed includes all forms and matters of copyrightable materials and information now allowed by statutory or judicial law or hereinafter granted. Product names used in this document may be trademarks or registered trademarks of their respective companies and are hereby acknowledged. All non-ELATION brands and product names are trademarks or registered trademarks of their respective companies.

Elation Professional USA | 6122 S. Eastern Ave. | Los Angeles, CA. 90040

323-582-3322 | 323-832-9142 fax | www.elationlighting.com | info@elationlighting.com

Elation Professional B.V. | Junostraat 2 | 6468 EW Kerkrade, The Netherlands

+31 45 546 85 66 | +31 45 546 85 96 fax | www.elationlighting.eu | info@elationlighting.eu

Elation Professional Mexico | AV Santa Ana 30 | Parque Industrial Lerma, Lerma, Mexico 52000

+52 (728) 282-7070

CONTENTS

Testing Process	4
Full ON	5
White	8
Amber	11

Testing Process

Total Lumen Measurements

Lumens are measured using a Viso Systems Lab Spion. As a goniophotometer, the Viso calculates the field lumens of the fixture by taking multiple measurements across the light beam.

Many lumens figures provided for entertainment lighting fixtures are only 2π sphere values, some even emphasize the LED engine lumens. All Elation product photometric data is the actual light output from the fixture lens, never a theoretical value based on calculation or using the source lumens as the fixtures output. We advise to always compare total fixture lumens acquired with identical measurement systems when comparing lighting fixtures.

Test Lab Equipment and Process

Elation operates an optical testing laboratory at its Los Angeles, CA headquarters to provide accurate photometric data for its lighting products. The testing lab is both light and climate-controlled and contains a variety of precise lighting measurement systems. Fixtures are analyzed with the sophisticated [Viso Systems Lab Spion](#) equipment, which measures all light and color parameters by panning the light beam at a precise speed and from different angles through a calibrated, laser aligned light and color sensor. Test data is collected and summarized by the Viso Light Inspector software. This type of measurement system is referred to as a Goniophotometer.

The Viso software calculates all relevant types of measurements, from beam angles, candela to center light intensity at a variety of distances to the latest color quality measurements like TM30 or CQS as well as accurate color temperature. This wealth of data is then processed by an Elation specific template which is included in the photometric test report for various fixture conditions such as zoom angles and color correction filters.

The Viso software also creates IES (Illuminating Engineering Society) files for each test report. IES is an industry standard file format created for the easy electronic transfer of photometric test data, which is widely used by lighting manufacturers for photometric data distribution.

Additionally, fixtures are periodically rechecked for accuracy using various hand-held light meters including one or more of the devices listed below. This is done to ensure the test data contained in this report is as accurate as possible.

[Asenstek Lighting Passport](#) | [Konica Minolta T-10](#) | [Sekonic C700T](#)

Total Lumen Output: 10058 lm

Color Temperature: 2758 K

CRI: 93.0

TLCI: 3

TM30: 92.0

CQS: 90.8

Measurement Date: 10/29/2020

Voltage: 111 V, Current: 1.77 A

Power: 191 W

Efficacy: 53 Lumen/Watt

Spectral distribution
Dominant Wavelength 584

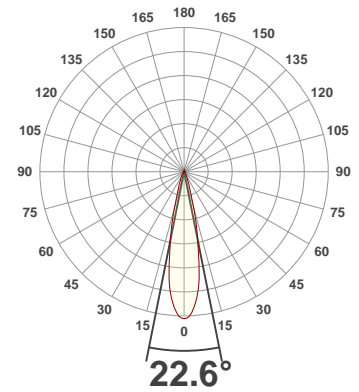
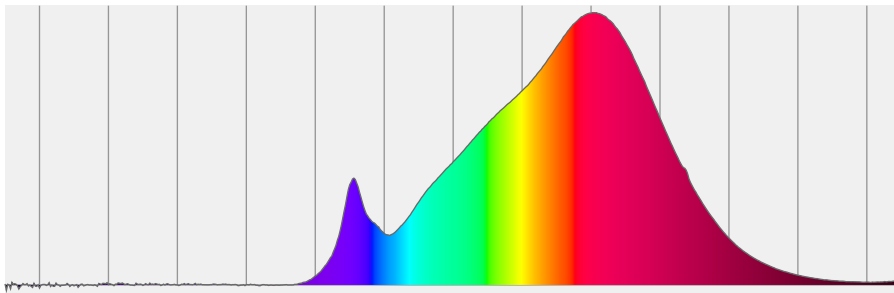

Beam details

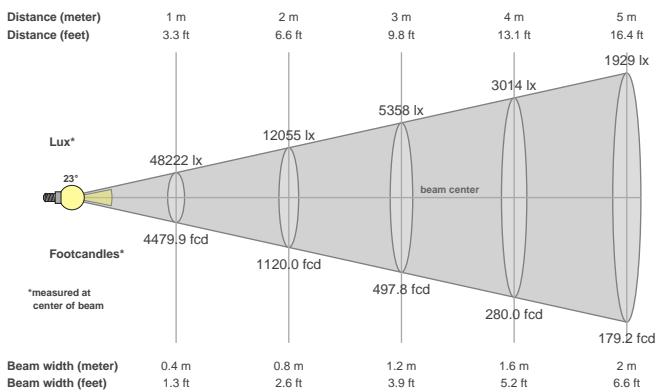

Beam angles

Beam angle 50%	Field angle 10%	Cutoff angle 2,5%
22.6°	41.3°	68.1°

Beam intensities

Peak intensity	Int. ratio in 120° cone	Int. ratio in 90° cone
48257 cd	98.8%	95.2%

Beam Intensities from 1-20m

M	1	2	3	4	5	6	7	8	9	10	11	12	13	14	15	16	17	18	19	20
FT	3.3	6.6	9.8	13.1	16.4	19.7	23	26.2	29.5	32.8	36.1	39.4	42.7	45.9	49.2	52.5	55.8	59.1	62.3	65.6
LX	48222	12055	5358	3014	1929	1339	984	753	595	482	399	335	285	246	214	188	167	149	134	121
FC	4479.9	1120	497.8	280	179.2	124.4	91.4	70	55.3	44.8	37	31.1	26.5	22.9	19.9	17.5	15.5	13.8	12.4	11.2

Color Details

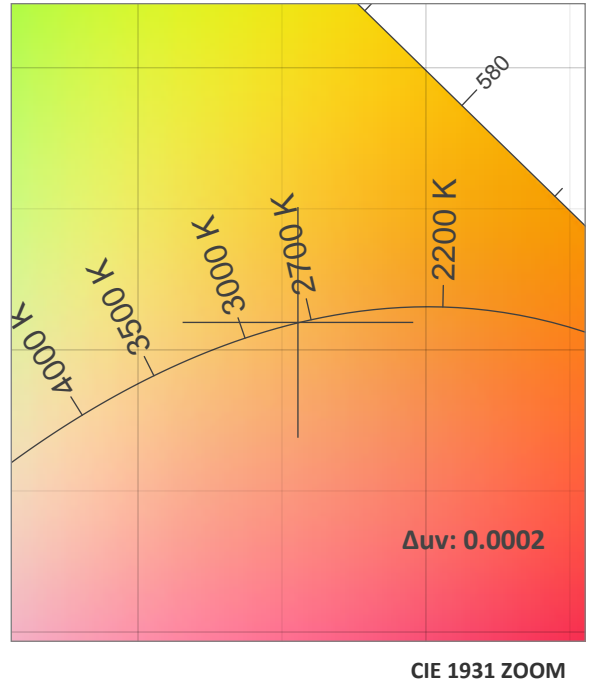
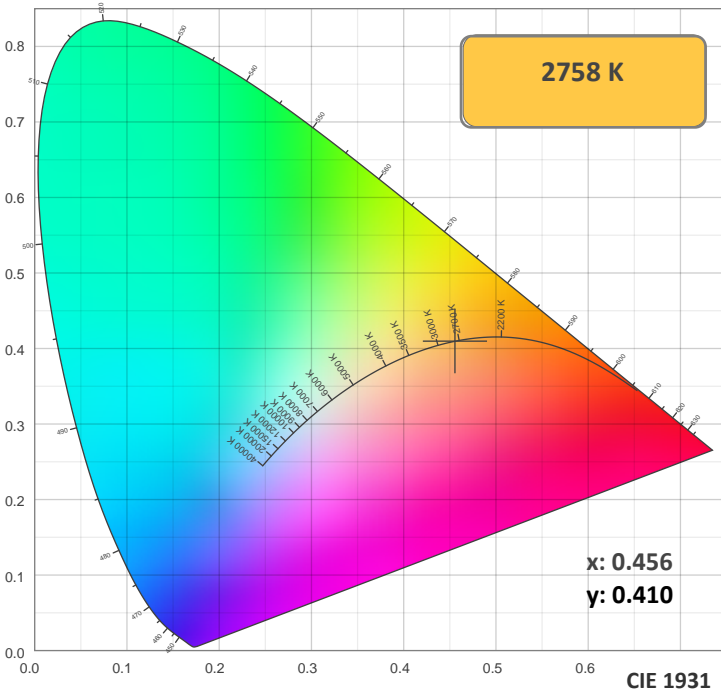

TM30: 92.0

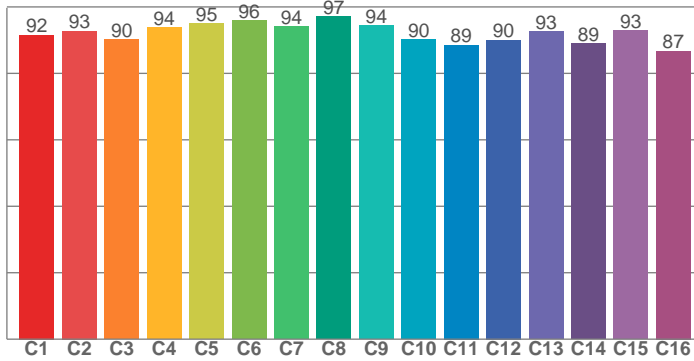

CRI: 93.0 (R1-R8)

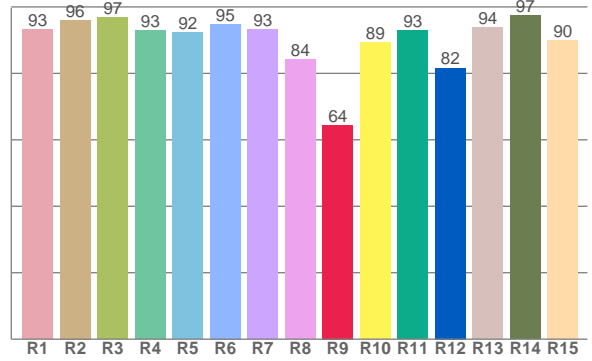

CRI R values, only R1-R8 are used to calculate final CRI value

R1	R2	R3	R4	R5	R6	R7	R8	R9	R10	R11	R12	R13	R14	R15
93.1	96.0	96.9	93.0	92.4	94.8	93.2	84.1	64.5	89.2	93.0	81.7	93.8	97.4	89.9

TM30 C Values, 16 binned values out of total of 99 C values

C1	C2	C3	C4	C5	C6	C7	C8	C9	C10	C11	C12	C13	C14	C15	C16
91.5	92.7	90.2	93.8	95.0	96.0	94.0	97.0	94.4	90.1	88.5	90.1	92.6	89.0	92.9	86.7

CQS Q Values

Q1	Q2	Q3	Q4	Q5	Q6	Q7	Q8	Q9	Q10	Q11	Q12	Q13	Q14	Q15
89.4	95.6	88.3	87.7	90.6	91.2	90.6	92.1	97.0	93.3	92.5	92.4	92.4	88.0	88.3

CQS: 90.8

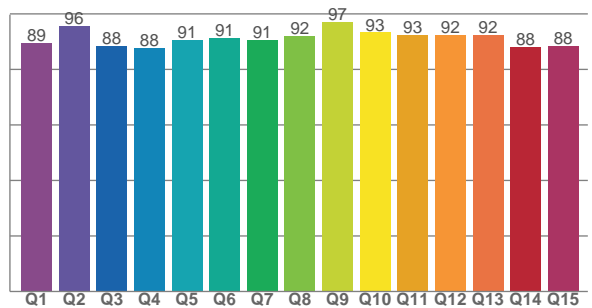

Color Parameters

Color Temperature	Color Rendering Index	Red Component	Color Fidelity	Color Gamut	Color Quality Scale	Color Coordinate CIE 1931	Color Coordinate CIE 1931	Color Coordinate	Color Coordinate	Color Diviation from Black
CCT	CRI	CRI R9	TM30 Rf	TM30 Rg	CQS	x	y	u	v	Δuv
2758 K	93.0	64.5	92.0	99.4	90.8	0.456	0.410	0.260	0.351	0.0002

TM30 Details

Rf 92.0
Fidelity Index Rf

Rg 99.4
Gamut Index Rg

Hue Bin	R _f	Graphic shifts (%)	
		Chroma	Hue
1	92	-4%	0%
2	93	-3%	2%
3	90	-1%	5%
4	94	-1%	2%
5	95	1%	3%
6	96	2%	0%
7	94	-2%	-2%
8	97	-1%	-1%
9	94	-2%	2%
10	90	-1%	6%
11	89	1%	9%
12	90	5%	2%
13	93	3%	-4%
14	89	4%	-8%
15	93	-1%	-4%
16	87	-2%	-10%

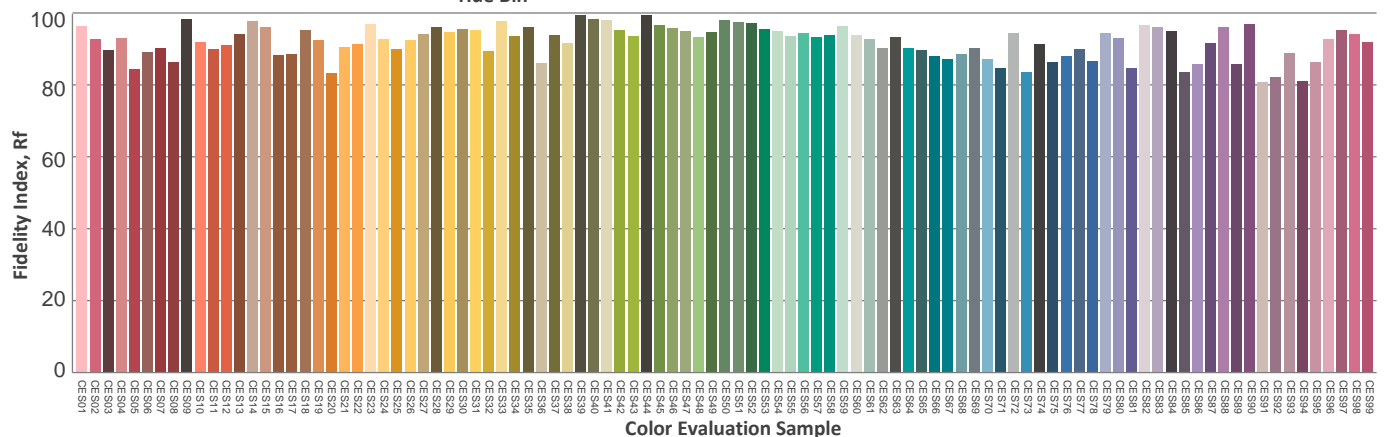
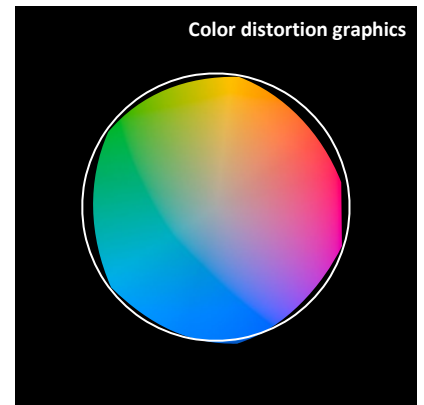
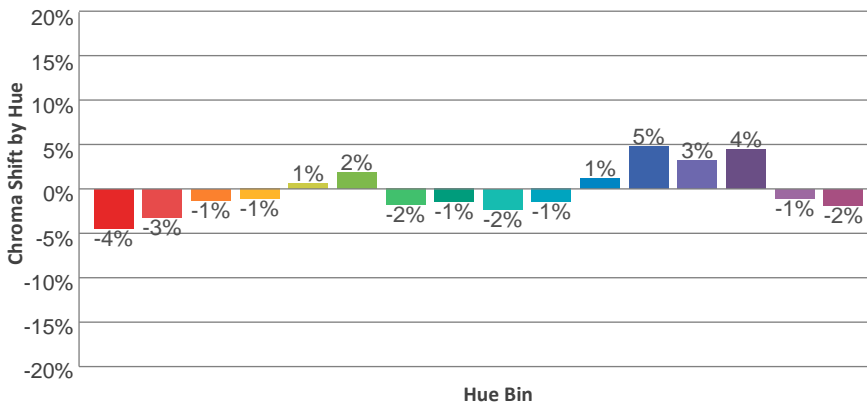
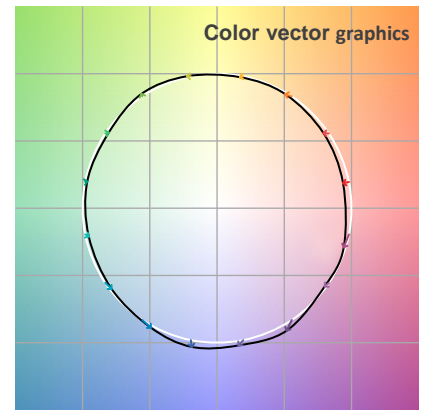
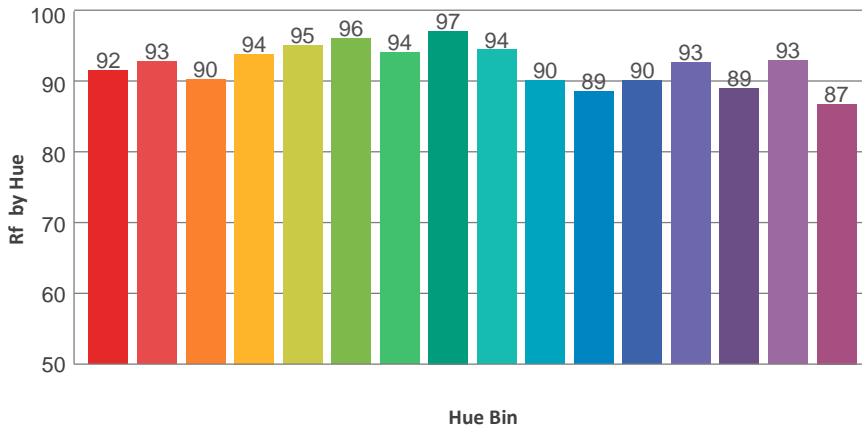
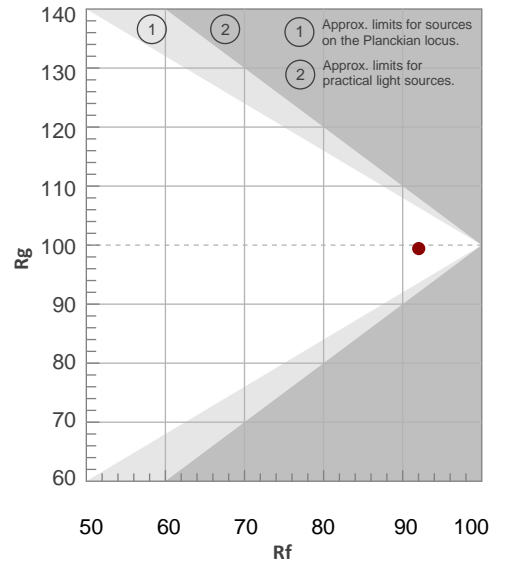

Total Lumen Output: 11070 lm

Color Temperature: 2989 K

CRI: 91.8

TLCI: n/a

TM30: 91.3

CQS: 90.5

Measurement Date: 10/29/2020

Voltage: 113 V, Current: 1.53 A

Power: 168.3 W

Efficacy: 66 Lumen/Watt

Spectral distribution
Dominant Wavelength 583

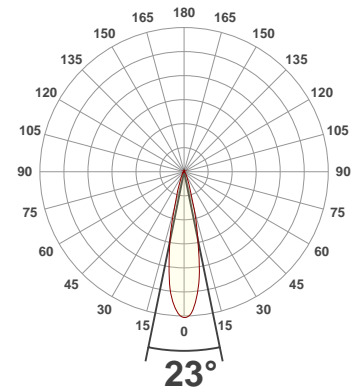
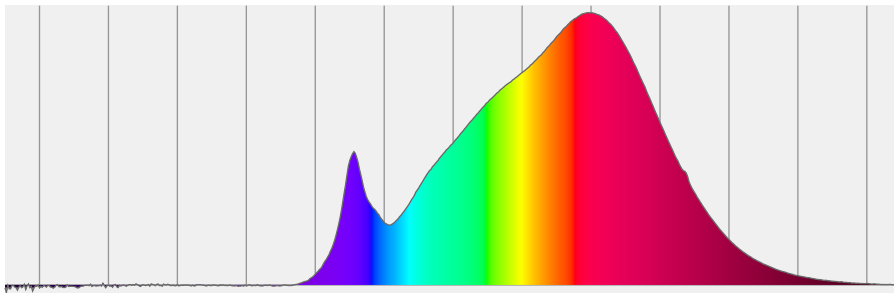

Beam details

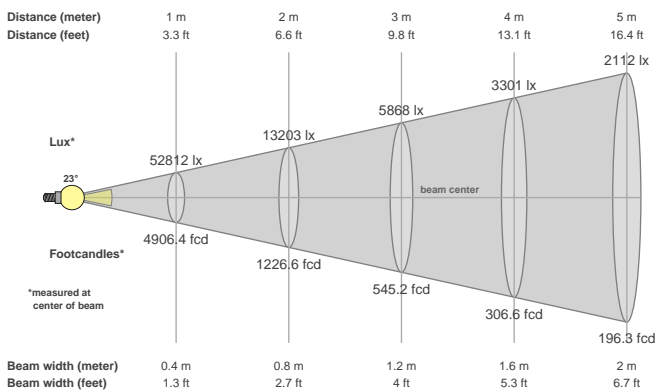

Beam angles

Beam angle 50%	Field angle 10%	Cutoff angle 2,5%
23°	41.8°	67.7°

Beam intensities

Peak intensity	Int. ratio in 120° cone	Int. ratio in 90° cone
53164 cd	99.8%	96.9%

Beam Intensities from 1-20m

M	1	2	3	4	5	6	7	8	9	10	11	12	13	14	15	16	17	18	19	20
FT	3.3	6.6	9.8	13.1	16.4	19.7	23	26.2	29.5	32.8	36.1	39.4	42.7	45.9	49.2	52.5	55.8	59.1	62.3	65.6
LX	52812	13203	5868	3301	2112	1467	1078	825	652	528	436	367	312	269	235	206	183	163	146	132
FC	4906.4	1226.6	545.2	306.6	196.3	136.3	100.1	76.7	60.6	49.1	40.5	34.1	29	25	21.8	19.2	17	15.1	13.6	12.3

Color Details

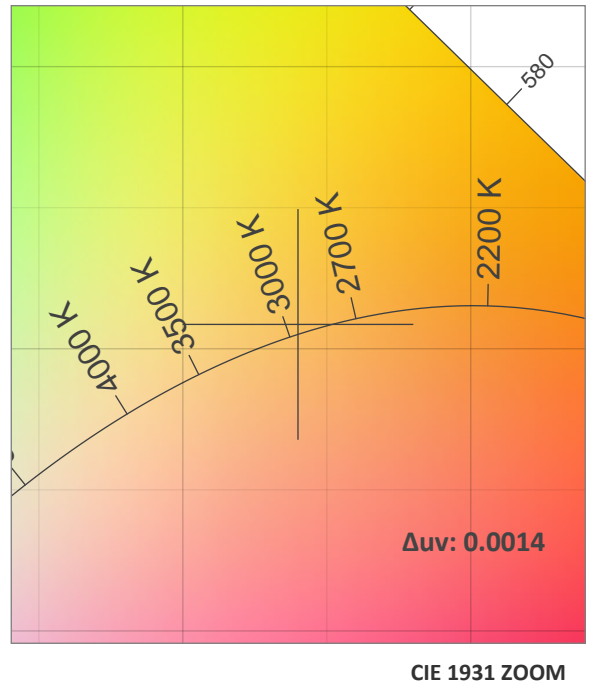
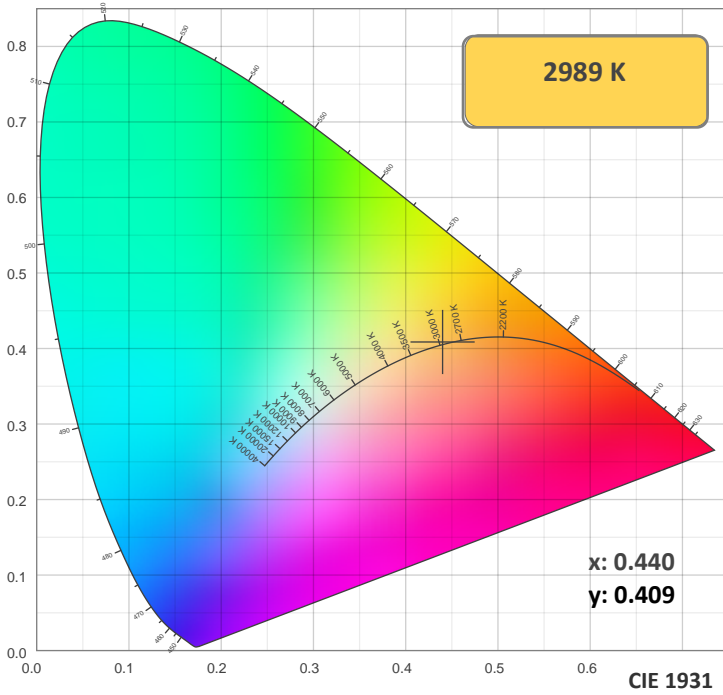

TM30: 91.3

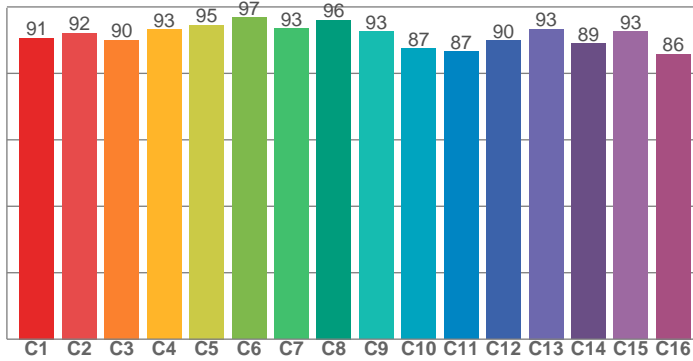

CRI: 91.8 (R1-R8)

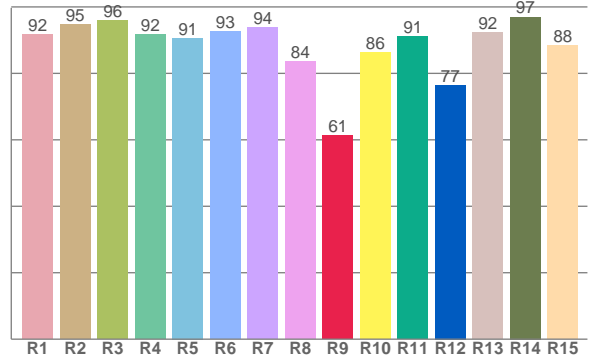

CRI R values, only R1-R8 are used to calculate final CRI value

R1	R2	R3	R4	R5	R6	R7	R8	R9	R10	R11	R12	R13	R14	R15
91.7	94.7	96.0	91.8	90.6	92.7	93.7	83.5	61.2	86.2	91.2	76.5	92.3	97.0	88.5

TM30 C Values, 16 binned values out of total of 99 C values

C1	C2	C3	C4	C5	C6	C7	C8	C9	C10	C11	C12	C13	C14	C15	C16
90.7	92.2	90.1	93.2	94.6	96.7	93.4	96.1	92.6	87.4	86.5	89.8	93.3	88.9	92.7	85.8

CQS Q Values

Q1	Q2	Q3	Q4	Q5	Q6	Q7	Q8	Q9	Q10	Q11	Q12	Q13	Q14	Q15
89.5	96.3	87.6	86.4	89.3	90.3	91.0	93.1	97.0	93.5	92.5	92.4	92.4	87.3	88.1

CQS: 90.5

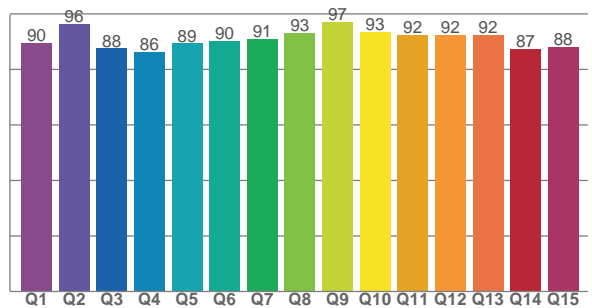

Color Parameters

Color Temperature	Color Rendering Index	Red Component	Color Fidelity	Color Gamut	Color Quality Scale	Color Coordinate CIE 1931	Color Coordinate CIE 1931	Color Coordinate	Color Coordinate	Color Diviation from Black
CCT	CRI	CRI R9	TM30 Rf	TM30 Rg	CQS	x	y	u	v	Δuv
2989 K	91.8	61.2	91.3	98.4	90.5	0.440	0.409	0.251	0.349	0.0014

TM30 Details

Rf 91.3
Fidelity Index Rf

Rg 98.4
Gamut Index Rg

Hue Bin	R _f	Graphic shifts (%)	
		Chroma	Hue
1	91	-5%	0%
2	92	-4%	2%
3	90	-2%	5%
4	93	-2%	2%
5	95	0%	3%
6	97	1%	0%
7	93	-3%	-1%
8	96	-2%	0%
9	93	-3%	3%
10	87	-2%	8%
11	87	1%	10%
12	90	5%	3%
13	93	3%	-3%
14	89	5%	-7%
15	93	-1%	-4%
16	86	-2%	-11%

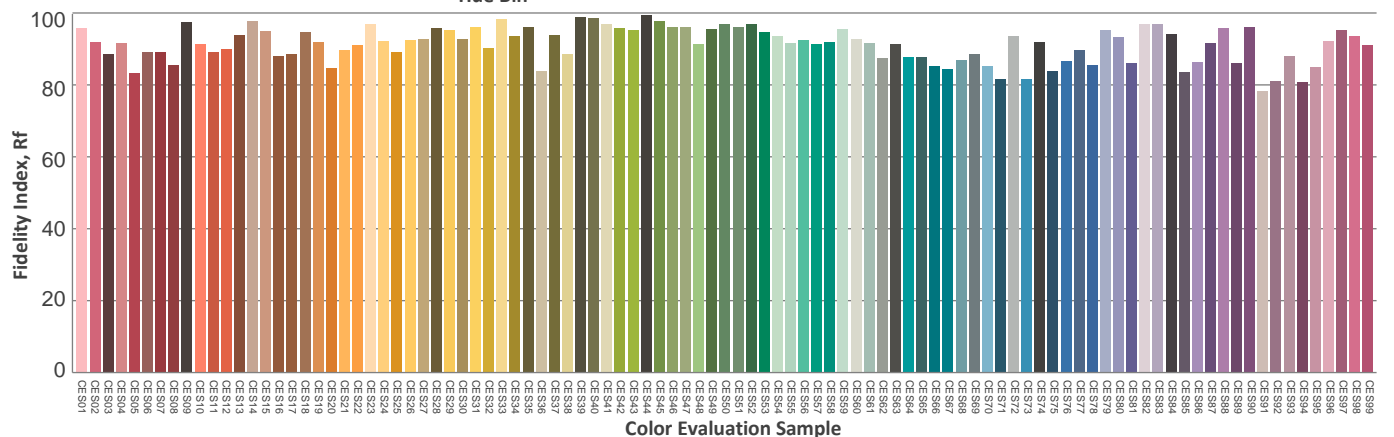
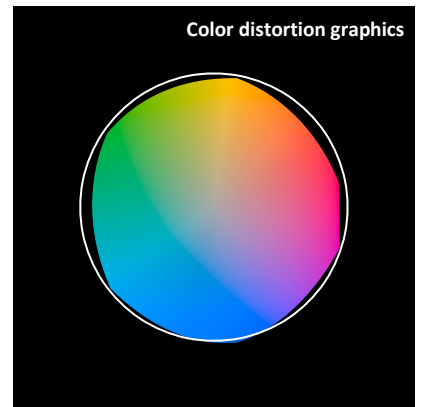
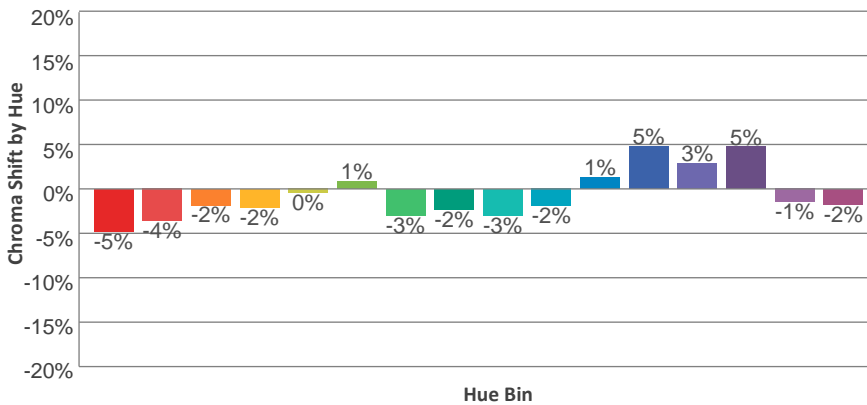
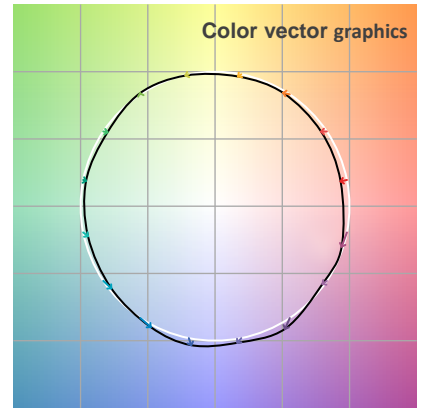
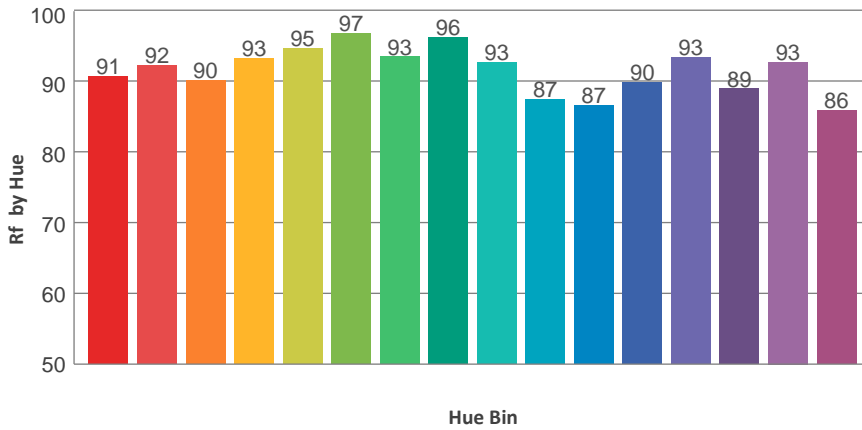
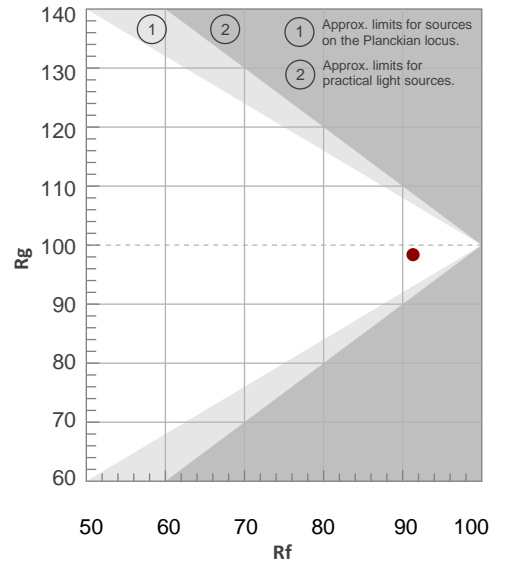

Total Lumen Output: 2079 lm

Color Temperature: 1996 K

CRI: 91.5

TLCI: 26

TM30: 90.7

CQS: 78.1

Measurement Date: 10/29/2020

Voltage: 115 V, Current: 0.538 A

Power: 55.3 W

Efficacy: 38 Lumen/Watt

Spectral distribution
Dominant Wavelength 589

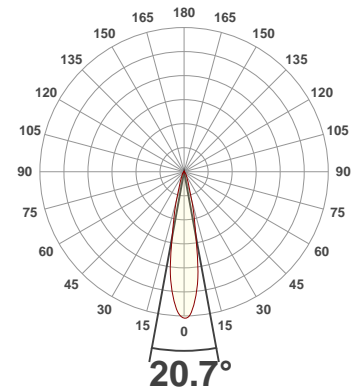
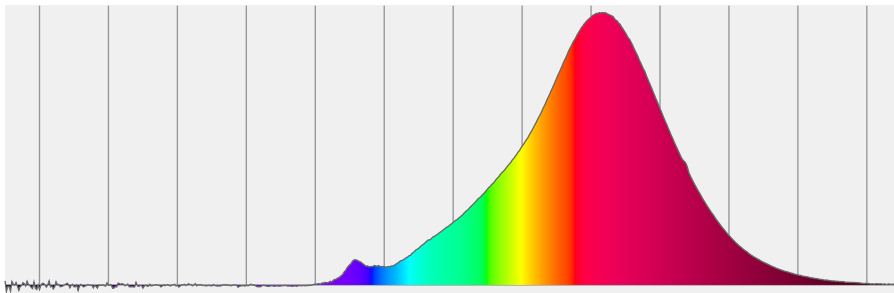

Beam details

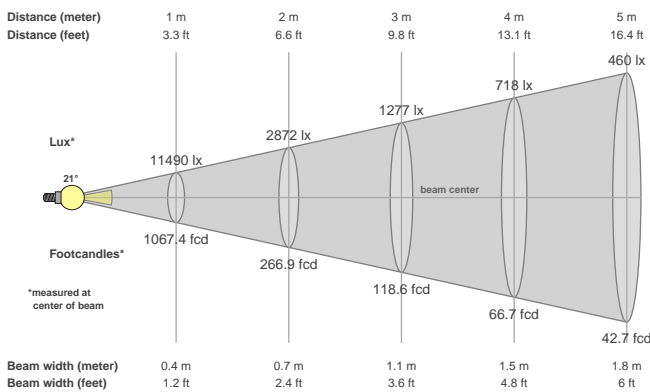

Beam angles

Beam angle 50%	Field angle 10%	Cutoff angle 2,5%
20.7°	38.2°	65°

Beam intensities

Peak intensity	Int. ratio in 120° cone	Int. ratio in 90° cone
11608 cd	99.6%	96.6%

Beam Intensities from 1-20m

M	1	2	3	4	5	6	7	8	9	10	11	12	13	14	15	16	17	18	19	20
FT	3.3	6.6	9.8	13.1	16.4	19.7	23	26.2	29.5	32.8	36.1	39.4	42.7	45.9	49.2	52.5	55.8	59.1	62.3	65.6
LX	11490	2872	1277	718	460	319	234	180	142	115	95	80	68	59	51	45	40	35	32	29
FC	1067.4	266.9	118.6	66.7	42.7	29.7	21.8	16.7	13.2	10.7	8.8	7.4	6.3	5.4	4.7	4.2	3.7	3.3	3	2.7

Color Details

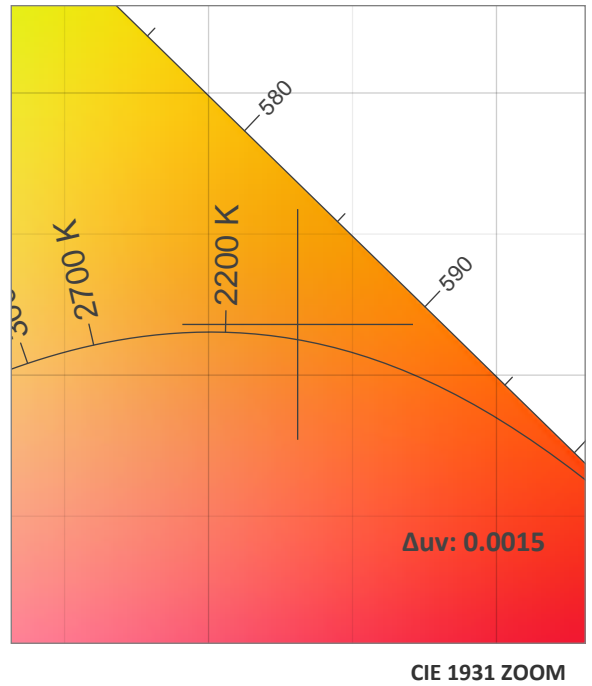
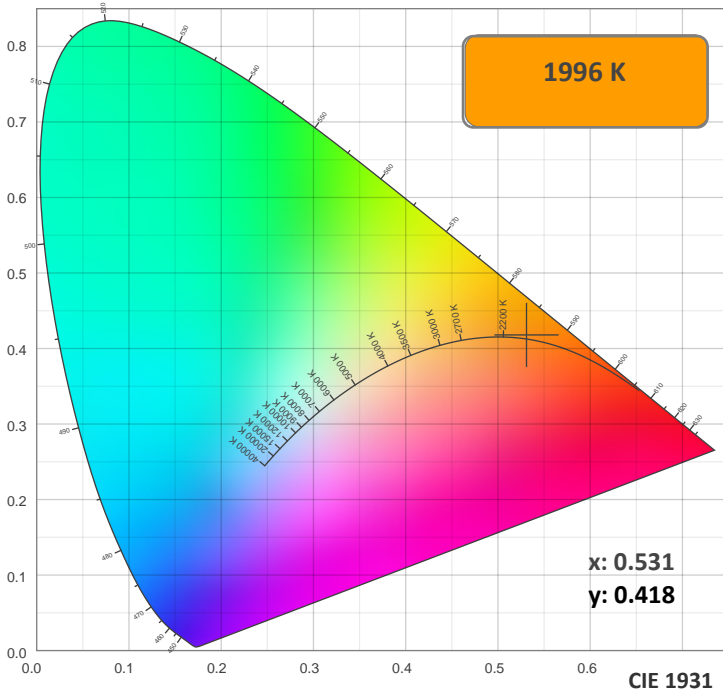

TM30: 90.7

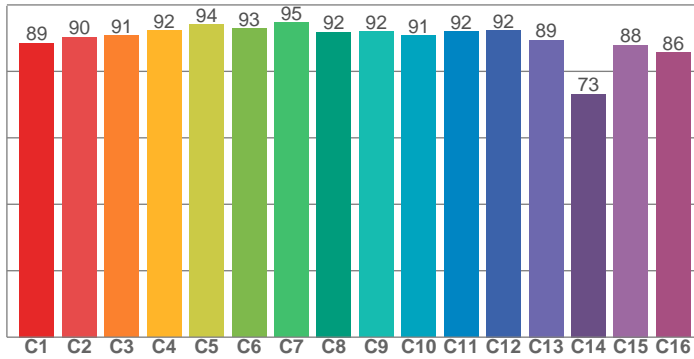

CRI: 91.5 (R1-R8)

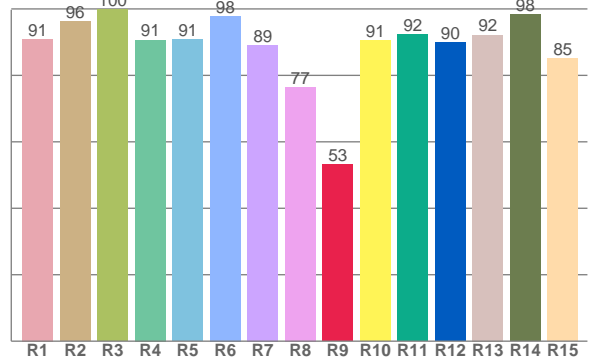

CRI R values, only R1-R8 are used to calculate final CRI value

R1	R2	R3	R4	R5	R6	R7	R8	R9	R10	R11	R12	R13	R14	R15
91.0	96.3	99.8	90.7	90.7	97.8	89.1	76.5	53.1	90.5	92.3	89.9	92.2	98.3	85.1

TM30 C Values, 16 binned values out of total of 99 C values

C1	C2	C3	C4	C5	C6	C7	C8	C9	C10	C11	C12	C13	C14	C15	C16
88.5	90.3	90.8	92.4	94.1	92.8	94.6	91.9	92.0	90.7	91.9	92.4	89.4	73.2	87.9	85.7

CQS Q Values

Q1	Q2	Q3	Q4	Q5	Q6	Q7	Q8	Q9	Q10	Q11	Q12	Q13	Q14	Q15
77.3	82.8	83.5	81.8	81.7	81.7	81.1	81.5	78.4	74.2	73.7	76.1	78.3	73.3	76.2

CQS: 78.1

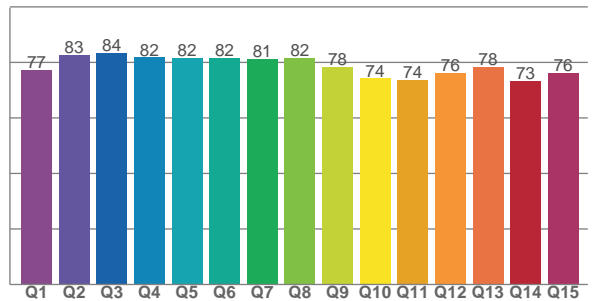

Color Parameters

Color Temperature	Color Rendering Index	Red Component	Color Fidelity	Color Gamut	Color Quality Scale	Color Coordinate CIE 1931	Color Coordinate CIE 1931	Color Coordinate	Color Coordinate	Color Diviation from Black
CCT	CRI	CRI R9	TM30 Rf	TM30 Rg	CQS	x	y	u	v	Δuv
1996 K	91.5	53.1	90.7	94.9	78.1	0.531	0.418	0.305	0.361	0.0015

TM30 Details

Rf 90.7
Fidelity Index Rf

Rg 94.9
Gamut Index Rg

Hue Bin	R _f	Graphic shifts (%)	
		Chroma	Hue
1	89	-6%	1%
2	90	-5%	2%
3	91	-4%	3%
4	92	-6%	0%
5	94	-5%	2%
6	93	-2%	4%
7	95	-4%	1%
8	92	-4%	5%
9	92	-2%	4%
10	91	-2%	5%
11	92	2%	5%
12	92	3%	1%
13	89	1%	-11%
14	73	-4%	-14%
15	88	-4%	-8%
16	86	-6%	-7%

