

**VOLT Q3™**  
user manual

©2013 **ELATION PROFESSIONAL** all rights reserved. Information, specifications, diagrams, images, and instructions herein are subject to change without notice. ELATION PROFESSIONAL logo and identifying product names and numbers herein are trademarks of ELATION PROFESSIONAL. Copyright protection claimed includes all forms and matters of copyrightable materials and information now allowed by statutory or judicial law or hereinafter granted. Product names used in this document may be trademarks or registered trademarks of their respective companies and are hereby acknowledged. All non-ELATION brands and product names are trademarks or registered trademarks of their respective companies.

**ELATION PROFESSIONAL** and all affiliated companies hereby disclaim any and all liabilities for property, equipment, building, and electrical damages, injuries to any persons, and direct or indirect economic loss associated with the use or reliance of any information contained within this document, and/or as a result of the improper, unsafe, insufficient and negligent assembly, installation, rigging, and operation of this product.

**Elation Professional USA** | 6122 S. Eastern Ave. | Los Angeles, CA. 90040  
323-582-3322 | 323-832-9142 fax | [www.elationlighting.com](http://www.elationlighting.com) | [info@elationlighting.com](mailto:info@elationlighting.com)

**Elation Professional B.V.** | Junostraat 2 | 6468 EW Kerkrade, Netherlands  
+31 45 546 85 66 | +31 45 546 85 96 fax | [www.elationlighting.eu](http://www.elationlighting.eu) | [info@elationlighting.eu](mailto:info@elationlighting.eu)

## DOCUMENT VERSION



Please check [www.elationlighting.com](http://www.elationlighting.com) for the latest revision/update of this manual.

| Date | Document Version | Software Version | DMX Channel Modes | Notes            |
|------|------------------|------------------|-------------------|------------------|
| 2013 | 1                | ≥V1.0            | 4 / 5 / 7 / 9     | Initial release. |

# CONTENTS

|                                       |    |
|---------------------------------------|----|
| General Information                   | 4  |
| Warranty                              | 7  |
| Safety Instructions                   | 8  |
| General Guidelines                    | 9  |
| Fixture Overview                      | 10 |
| Battery Charging                      | 11 |
| Fixture Installation                  | 12 |
| Understanding DMX                     | 15 |
| Fixture Menu                          | 18 |
| Internal Wireless DMX Receiver Set Up | 26 |
| DMX Channel Functions And Values      | 28 |
| Cleaning and Maintenance              | 30 |
| Technical Specifications              | 31 |
| Optional Accessories                  | 33 |

## GENERAL INFORMATION

### INTRODUCTION

Congratulations, you have just purchased one of the most innovative and reliable ArtNet to DMX converter on the market today! The **VOLT Q3™** has been designed to perform reliably for years when the guidelines in this booklet are followed. Please read and understand the instructions in this manual carefully and thoroughly before attempting to operate this unit. These instructions contain important information regarding safety during use and maintenance.



### IP65 RATED

An IP rated lighting fixture is one, which is commonly installed in outdoor environments and has been designed with an enclosure that effectively protects the ingress (entry) of external foreign objects such as dust and water. The **International Protection (IP)** rating system is commonly expressed as "IP" (Ingress Protection) followed by two numbers (i.e. IP65) where the numbers define the degree of protection. The first digit (Foreign Bodies Protection) indicates the extent of protection against particles entering the fixture and the second digit (Water Protection) indicates the extent of protection against water entering the fixture. An IP65 rated lighting fixture is one, which has been designed and tested to protect against the ingress of dust (6) and high-pressure water jets from any direction (5).



### MARINE/COASTAL ENVIRONMENT INSTALLATIONS!

Please note although this fixture is IP rated, the fixture is **NOT** suitable for marine and/or coastal environment installations. Installing this fixture in a marine and/or coastal environment may cause corrosion and/or excessive wear to the interior and/or exterior components of the fixture. Damages and/or performance issues resulting from installation in a marine and/or coastal environment will void the manufactures warranty and will **NOT** be subject to any warranty claims and/or repairs.



### OPTIONAL CORROSION-RESISTANT COATING

Optional Corrosion-Resistant Coatings may be available for this fixture. Please consult your **Elation Professional** sales representative for details.

## UNPACKING

Thank you for purchasing the **VOLT Q3™** by Elation Professional®. Every **VOLT Q3™** has been thoroughly tested and has been shipped in perfect operating condition. Carefully check the shipping carton for damage that may have occurred during shipping. If the carton appears to be damaged, carefully inspect your unit for damage and be sure all accessories necessary to operate the unit have arrived intact. In the event damage has been found or parts are missing, please contact our customer support team for further instructions. Please do not return this unit to your dealer without first contacting customer support at the number listed below. Please do not discard the shipping carton in the trash. Please recycle whenever possible.

## BOX CONTENTS

- (1) Charging Power Supply + IEC Power Cable
- (1) 9.8 ft. (3m) 3pin IP Female to 3pin IP Male DATA LINK Cable
- (1) 9.8 ft. (3m) 3pin IP Female to 3pin DMX Male DATA INPUT Cable
- (1) Magnetic Frost Filter
- (1) Omega Bracket

## CUSTOMER SUPPORT

Elation Professional® provides a customer support line, to provide set up help and to answer any question should you encounter problems during your set up or initial operation. You may also visit us on the web at [www.elationlighting.com](http://www.elationlighting.com) for any comments or suggestions. For service related issue please contact Elation Professional®.

### **ELATION SERVICE USA - Monday - Friday 8:00am to 5:00pm PST**

**Voice: 323-582-3322**

**Fax: 323-832-9142**

E-mail: [support@elationlighting.com](mailto:support@elationlighting.com)

### **ELATION SERVICE EUROPE - Monday - Friday 08:30 to 17:00 CET**

**Voice: +31 45 546 85 30**

**Fax: +31 45 546 85 96**

E-mail: [support@elationlighting.eu](mailto:support@elationlighting.eu)

## WARRANTY REGISTRATION

Please fill out the enclosed warranty card to validate your purchase. All returned service items whether under warranty or not, must be freight pre-paid and accompany a return authorization (R.A.) number. The R.A. number must be clearly written on the outside of the return package. A brief description of the problem as well as the R.A. number must also be written down on a piece of paper and included in the shipping container. If the unit is under warranty, you must provide a copy of your proof of purchase invoice. Items returned without a R.A. number clearly marked on the outside of the package will be refused and returned at customer's expense. You may obtain a R.A. number by contacting customer support at 323-582-3322.

### **IMPORTANT NOTICE!**

**There are no user serviceable parts inside this unit. Do not attempt any repairs yourself; doing so will void your manufactures warranty. Damages resulting from modifications to this fixture and/or the disregard of safety and general user instructions found in this user manual void the manufactures warranty and are not subject to any warranty claims and/or repairs.**

## LIMITED WARRANTY

A. Elation Professional® hereby warrants, to the original purchaser, Elation Professional® products to be free of manufacturing defects in material and workmanship for a period of two years (730 days), and Elation Professional® product rechargeable batteries to be free of manufacturing defects in material and workmanship for a period of six months (180 days), from the original date of purchase. This warranty excludes discharge lamps and all product accessories. This warranty shall be valid only if the product is purchased within the United States of America, including possessions and territories. It is the owner's responsibility to establish the date and place of purchase by acceptable evidence, at the time service is sought.

B. For warranty service, send the product only to the Elation Professional® factory. All shipping charges must be pre-paid. If the requested repairs or service (including parts replacement) are within the terms of this warranty, Elation Professional® will pay return shipping charges only to a designated point within the United States. If any product is sent, it must be shipped in its original package and packaging material. No accessories should be shipped with the product. If any accessories are shipped with the product, Elation Professional® shall have no liability what so ever for loss and/or or damage to any such accessories, nor for the safe return thereof.

C. This warranty is void if the product serial number and/or labels are altered or removed; if the product is modified in any manner which Elation Professional® concludes, after inspection, affects the reliability of the product; if the product has been repaired or serviced by anyone other than the Elation Professional® factory unless prior written authorization was issued to purchaser by Elation Professional®; if the product is damaged because not properly maintained as set forth in the product instructions, guidelines and/or user manual.

D. This is not a service contract, and this warranty does not include any maintenance, cleaning or periodic check-up. During the periods as specified above, Elation Professional® will replace defective parts at its expense, and will absorb all expenses for warranty service and repair labor by reason of defects in material or workmanship. The sole responsibility of Elation Professional® under this warranty shall be limited to the repair of the product, or replacement thereof, including parts, at the sole discretion of Elation Professional®. All products covered by this warranty were manufactured after January 1, 1990, and bare identifying marks to that effect.

E. Elation Professional® reserves the right to make changes in design and/or performance improvements upon its products without any obligation to include these changes in any products theretofore manufactured.

F. No warranty, whether expressed or implied, is given or made with respect to any accessory supplied with the products described above. Except to the extent prohibited by applicable law, all implied warranties made by Elation Professional® in connection with this product, including warranties of merchantability or fitness, are limited in duration to the warranty periods set forth above. And no warranties, whether expressed or implied, including warranties of merchantability or fitness, shall apply to this product after said periods have expired. The consumer's and/or dealer's sole remedy shall be such repair or replacement as is expressly provided above; and under no circumstances shall Elation Professional® be liable for any loss and/or damage, direct and/or consequential, arising out of the use of, and/or the inability to use, this product.

G. This warranty is the only written warranty applicable to Elation Professional® products and supersedes all prior warranties and written descriptions of warranty terms and conditions heretofore published.

## SAFETY INSTRUCTIONS



The **VOLT Q3™** is an extremely sophisticated piece of electronic equipment. To guarantee a smooth operation, it is important to follow the guidelines in this manual. The manufacturer of this device will not accept responsibility for damages resulting from the misuse of this fixture due to the disregard of the information printed in this manual.



This device falls under **PROTECTION CLASS 1**. It's essential this device be grounded properly. Only qualified personnel should perform all electrical connections.

### C A U T I O N S



**UNPLUG POWER BEFORE SERVICING FIXTURE**



**NEVER TOUCH FIXTURE DURING OPERATION AS IT MAY BE HOT**



**NEVER LOOK DIRECTLY INTO THE LIGHT SOURCE  
SENSITIVE PERSONS MAY SUFFER AN EPILEPTIC SHOCK**

- For proper operation, follow the **Installation** guidelines described in this manual. Only qualified and certified personnel should perform installation of this fixture and only the original rigging parts (brackets) included with this fixture should be used for installation. Any modifications will void the original manufacturer's warranty and increase the risk of damage and/or personal injury.
- Never look directly into the light source of this fixture to prevent risk of injury to your retina, which may induce blindness. Those suffering from **EPILEPSY** should avoid looking directly into the light source of this unit at all times.
- Always disconnect from main power source before performing any type of service and/or cleaning procedure. Only handle the power cord by the plug end, never pull out the plug by tugging the wire portion of the cord.
- Do not charge this fixture if the power cord has become frayed, crimped and/or damaged. If the power cord is damaged, replace it immediately with a new one of similar power rating.



## GENERAL GUIDELINES

- **NEVER OPEN THIS FIXTURE WHILE IN USE!**
- During the initial operation of this fixture, a light smoke or smell may emit from the interior of the fixture. This is a normal process and is caused by excess paint in the interior of the casing burning off from the heat associated with the lamp and will decrease gradually over time.
- Please make sure there are **NO FLAMMABLE MATERIALS** close to the fixture while operating, to prevent any fire hazard.
- **Minimum** distance of inflammable materials from the surface **1.6 feet (0.5m)**.
- **DO NOT** attempt installation and/or operation without knowledge how to do so.
- **DO NOT** allow operation by persons who are not qualified to operate this type of fixture. Most damages are the result of operations by nonprofessionals.
- Consistent operational breaks may ensure the fixture will function properly for many years to come.
- **DO NOT** shake fixture, avoid brute force when installing and/or operating fixture.
- Always install the fixture with an appropriate safety cable. When installing the fixture in a suspended environment, always use mounting hardware that is no less than M10 x 25 mm, also be sure the hardware is insert in the pre-arranged screw holes in the bracket of the fixture.
- Use the original packaging and materials to transport the fixture in for service.
- **DO NOT TOUCH** the housing bare-hand during its operation. Turn OFF the power and allow approximately 15 minutes for the fixture to cool down before replacing or serving.

## FIXTURE OVERVIEW

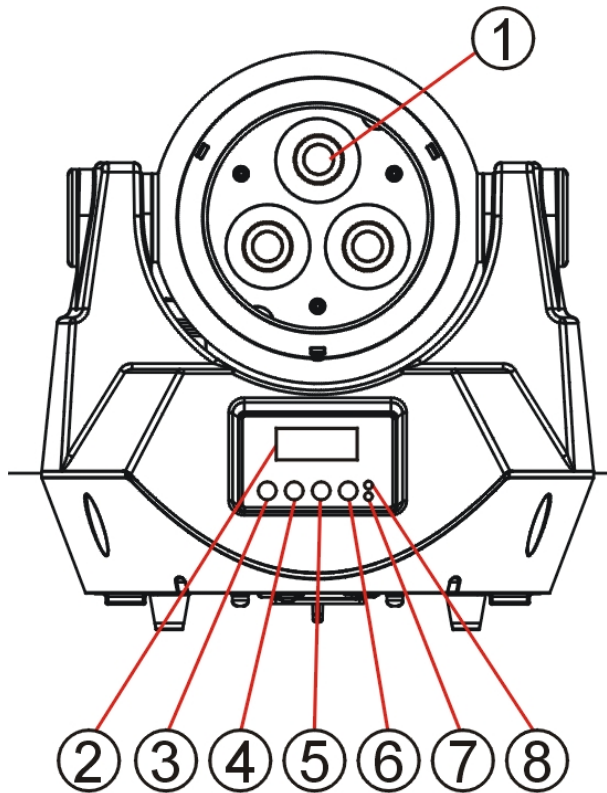

1. LED Lens
2. LCD Menu Display
3. MODE/ESC Button
4. UP Button
5. DOWN Button
6. ENTER Button
7. Charge Indicator
8. Wireless DMX Indicator

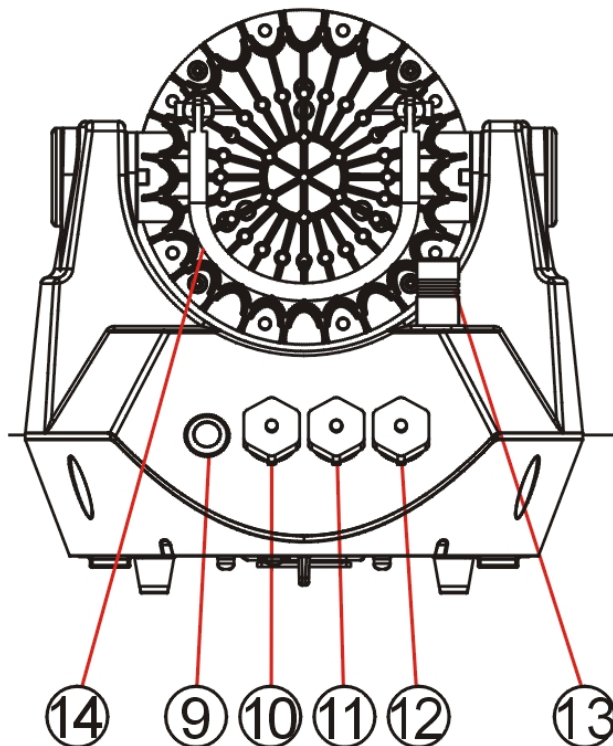

9. Power Switch
10. Power IN
11. DMX IN
12. DMX OUT
13. Wireless DMX Antenna
14. Carrying Handle

## BATTERY CHARGING

The **VOLT Q3™** internal rechargeable Lithium-Ion battery provides up to **6 hours** of operation at FULL ON 100% intensity.

 Please note battery life will vary depending on fixture usage and settings, install location temperature, and number of charge cycles.

### CHARGE TIME

Unit must be connected to charger a period of **8 hours** to fully charge the battery.

### RECHARGING AFTER USE

Connect the unit to the charger when the battery level reaches approximately **20%**.

To check the battery life level, access the **BattInfo** menu on unit LCD menu display.

## FIXTURE INSTALLATION



### **FLAMMABLE MATERIAL WARNING**

Keep fixture at least 5.0 ft (1.5m) away from any flammable materials, decorations, pyrotechnics, etc.



### **ELECTRICAL CONNECTIONS**

A qualified electrician should be used for all electrical connections and/or installations.

## **CAUTIONS**

- For added protection, mount the fixture in areas outside walking paths, seating areas, or in areas where unauthorized personnel might reach the fixture.
- Ambient operating temperature range for this fixture is **14° - 113°F. (-10° - 45°C)**  
Do not use the fixture outside above or below this temperature range.
- Before mounting the fixture to any surface, make sure the installation area can hold a minimum point load of 10 times the weight of the fixture. **130 lbs / 59 kg)**
- Fixture installation must always be secured with a secondary safety attachment, such as an appropriate safety cable.
- Never stand directly below the device when mounting, removing or servicing.

## CLAMP MOUNTING

The **VOLT Q3™** provides a unique mounting bracket assembly that integrates the bottom of the base, the included **Omega Bracket** and safety cable rigging point in one unit (see the illustration below). When mounting this fixture to truss be sure to secure an appropriately rated clamps to the included omega brackets using a M10 screw fitted through the center hole of the **Omega Bracket**. Be sure to attach the included **Safety Cable** to the fixture using the safety cable rigging point integrated in the base assembly.

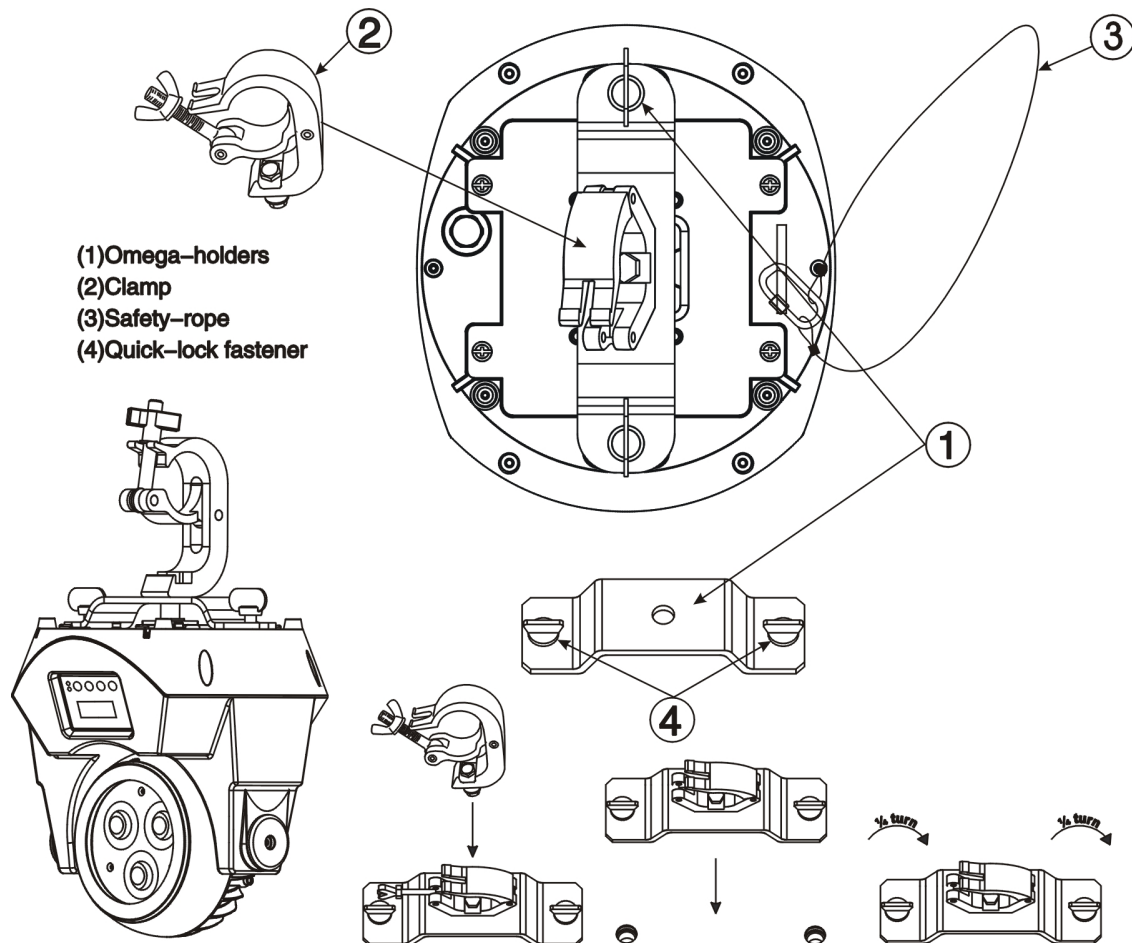

## SECURING

Regardless of the rigging option you choose for your **VOLT Q3™** always be sure to secure your fixture with a safety cable. The fixture provides a built-in rigging point for a safety cable on the hanging bracket as illustrated above. Be sure to only use the designated rigging point for the safety cable and never secure a safety cable to a carrying handle.

## MOUNTING POINTS

- Overhead mounting requires extensive experience, including amongst others calculating working load limits, installation material being used, and periodic safety inspection of all installation material and the device. If you lack these qualifications, do not attempt the installation yourself. Improper installation can result in bodily injury.
- Fixture is fully operational in the specific mounting positions as illustrated below.

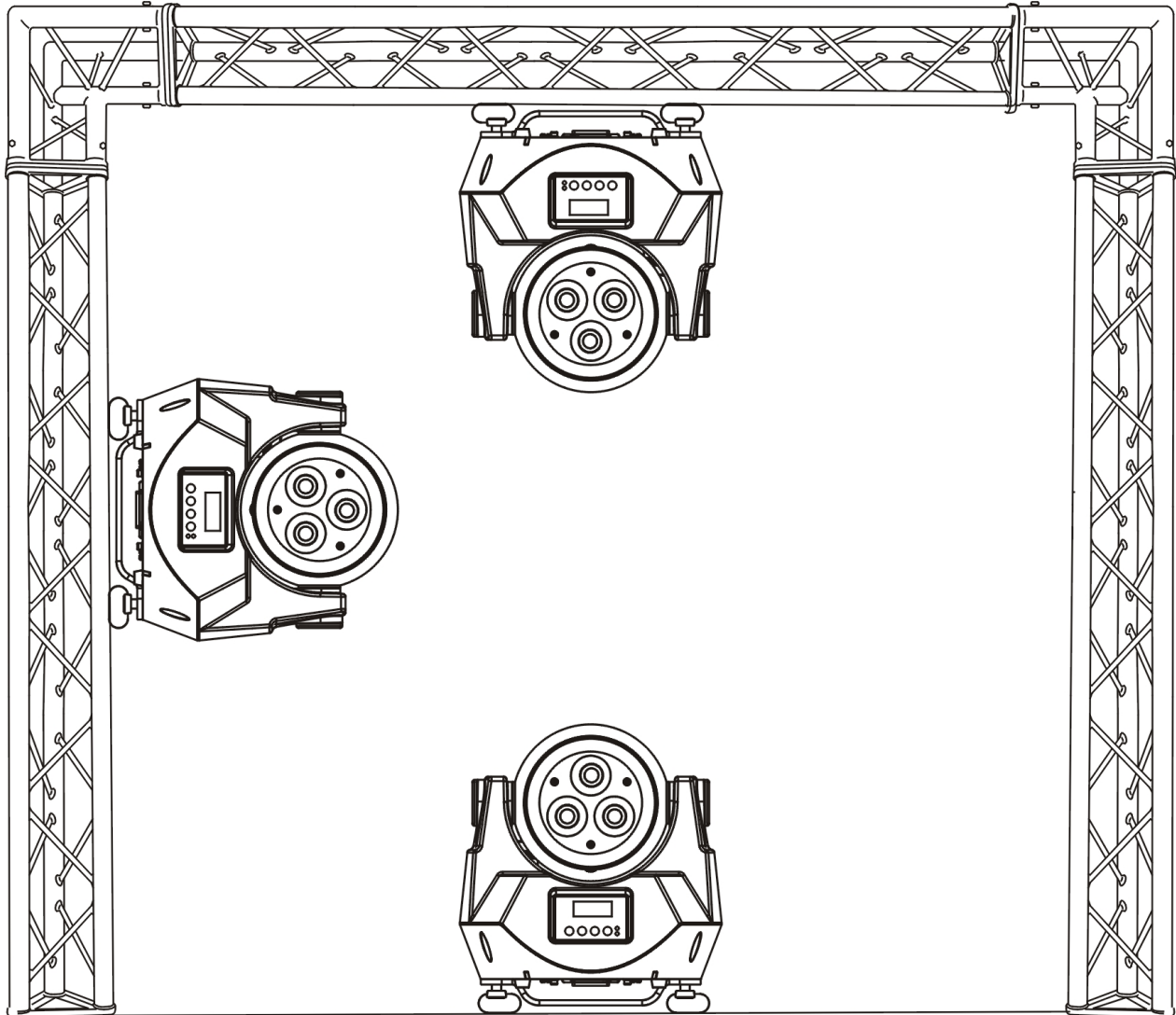

## SAFETY CABLE

**Always use a Safety Cable whenever installing this fixture in a suspended environment to ensure the fixture will not drop if the clamp fails.**

## UNDERSTANDING DMX

### DMX-512

DMX is short for Digital Multiplex. This is a universal protocol used by most lighting and controller manufactures as a form of communication between intelligent fixtures and controllers. DMX allows all makes and models of different manufactures to be linked together and operate from a single controller. This is possible as long as all the fixtures and the controller are DMX compliant. A DMX controller sends the DMX data instructions to the fixture allowing the user to control the different aspects of an intelligent light. DMX data is sent out as serial data that travels from fixture to fixture via data "IN" and data "OUT" XLR terminals located on the fixtures (most controllers will only have output jacks).

### DMX LINKING

To ensure proper DMX data transmission, always use the **VOLT™** series IP rated DMX cables listed in the **OPTIONAL ACCESSORIES** section at the end of this manual. When using several DMX fixtures try to use the shortest cable path possible. Never split a DMX line with a "Y" style connector. The order in which the fixtures are connected in a DMX line does not influence the DMX addressing. For example; a fixture assigned a starting DMX address of 1 may be placed anywhere in the DMX chain, at the beginning, at the end, or anywhere in the middle. The DMX controller knows to send data assigned to address 1 to that fixture no matter where it is located in the DMX chain. The **VOLT Q3™** can be controlled via DMX-512 protocol and the DMX address is set via the control menu.

### DMX-512 CONTROLLER CONNECTION

Connect the provided XLR cable to the female XLR output of your controller and the other side to the male 3pin input of the **VOLT Q3™**. The diagram below illustrates a typical DMX-512 connection when the fixture is in the **9 Channel Extended Mode**. You can chain multiple panels together through serial linking. The data link cable included must be used. Always be sure daisy chain your in and out data connections, never split or “Y” your DMX connections.

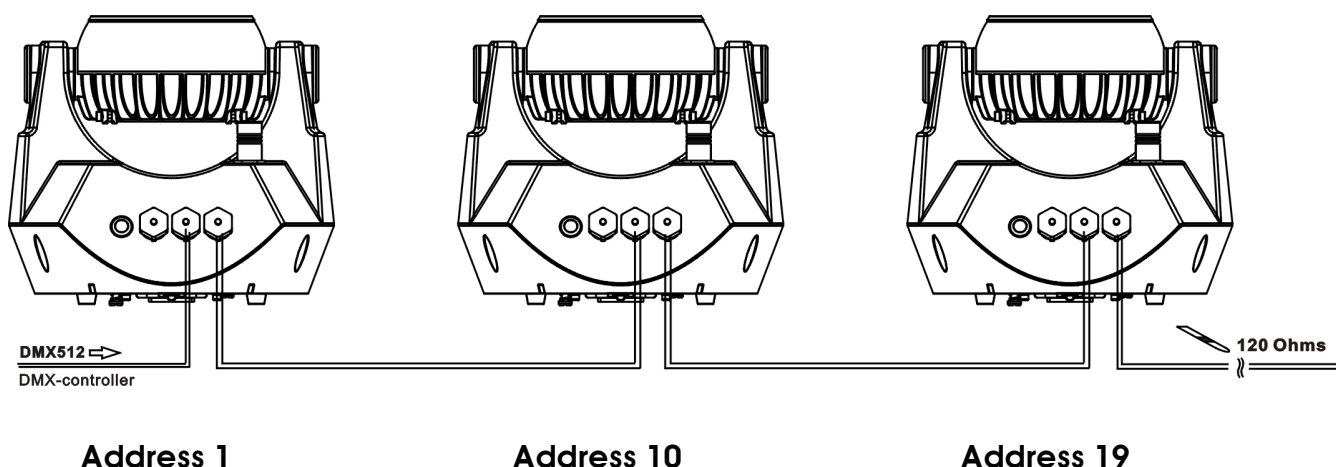

### DMX-512 CONNECTION WITH DMX TERMINATOR

A DMX terminator should be used in all DMX lines especially in longer runs. The use of a terminator may avoid erratic behavior in your DMX line. A terminator is a 120 ohm 1/4 watt resistor that is connected between pins 2 and 3 of a male XLR connector (DATA + and DATA -). This fixture is inserted in the female XLR connector of the last fixture in your daisy chain to terminate the line. Using a line terminator will decrease the possibilities of erratic behavior.

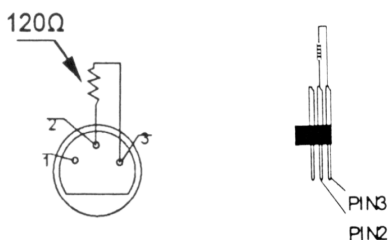

Termination reduces signal errors and avoids signal transmission problems and interference. It is always advisable to connect a DMX terminal, (Resistance 120 Ohm 1/4 W) between PIN 2 (DMX-) and PIN 3 (DMX +) of the last fixture.



## DMX ADDRESSING

All fixtures should be given a DMX starting address when using a DMX controller, so the correct fixture responds to the correct control signal. This digital starting address is the channel number from which the fixture starts to “listen” to the digital control information sent out from the DMX controller. The allocation of this starting DMX address is achieved by setting the correct DMX address on the digital display located on the back of the fixture.

You can set the same starting address for all fixtures or a group of fixtures, or set different address for each individual fixture. Be advised that setting all fixtures to the same DMX address will subsequently control all fixtures in the same fashion, in other words, changing the settings of one channel will affect all the fixtures simultaneously.

If you set each fixture to a different DMX address, each unit will start to “listen” to the channel number you have set, based on the quantity of control channels (DMX channels) of each fixture. That means changing the settings of one channel will only affect the selected fixture.

In the case of the **VOLT Q3™**, when in the **9 Channel Extended Mode** you should set the starting DMX address of the first unit to 1, the second unit to 10 (1 + 9), the third unit to 19 (10 + 9), and so on.

**Note:** During start-up the **VOLT Q3™** will automatically detect whether a DMX data signal is being received or not. If DMX data signal is being received, the display will show "**Addr=XXX**" (**XXX** representing the actual DMX address). If the fixture is not receiving a DMX signal the display will flash. If your fixture is connected to a DMX controller and the display is flashing (not receiving a DMX signal), please check the following:

- The 3pin XLR input plug (cable with DMX signal from controller) is not connected or is not inserted completely into the DMX input jack of the fixture.
- The DMX controller is switched off or defective.
- The DMX cable or connector is defective.
- A DMX terminator has been inserted into the last fixture in your DMX chain.

# FIXTURE MENU

## ON-BOARD SYSTEM MENU

The **VOLT Q3™** comes with an easy to navigate system menu. The next sections will cover how to access each menu function.

### LCD MENU CONTROL PANEL

The control panel located on the front of the fixture allows you to access the main menu and make all necessary adjustments to the **VOLT Q3™**. During normal operation, pressing **MODE/ESC** button once will access the fixture's main menu. Once in the main menu you can navigate through the different functions and access the sub-menus with the **UP** and **DOWN**, buttons. Once you reach a field that requires adjusting, press the **ENTER** button to activate that field and use the **UP** and **DOWN** buttons to adjust the field. Pressing the **ENTER** button once more will confirm your setting. You may exit the main menu at any time without making any adjustments by pressing the **MODE/ESC** button.



### INFORMATION DISPLAYED DURING INITIAL POWER ON

When the fixture is initially powered ON, the display shows the following information:

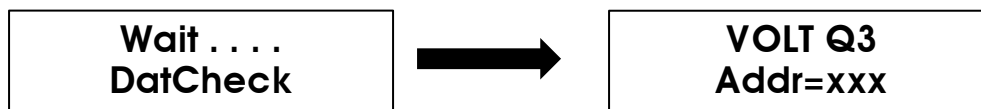

| ELATION® VOLT Q3™<br>SYSTEM MENU  |                |  |                                   |                                    |
|---|----------------|--|-----------------------------------|------------------------------------|
| Specifications and features are subject to change without any prior written notice. |                |  |                                   |                                    |
| MAIN MENU   | SUB MENU       | OPTIONS / VALUES (Default Settings in <b>BOLD</b> )    |                                   | DESCRIPTION                        |
| FuncMode  | Address        | A001 ~ AXXX  |                                   | DMX Address Setting                |
|   | ValuDisp       | ALL.....   |                                   | DMX Value Display                  |
|   | SetSlave       | Slave1, Slave2, Slave3                                 |                                   | Slave Setting                      |
|   | AutoProg       | Master / Alone   |                                   | Auto Program                       |
| Info  | TimeInfo       | Cur Time   | XXXX (Hours)                      | Fixture Run Time From Power ON     |
|   |                | TotalHrs   | XXXX (Hours)                      | Fixture Total Run Time             |
|   |                | Last Hrs   | XXXX (Hours)                      | Clear Fixture Last Run Time        |
|   |                | TimePass   | Password=XXX                      | Password <b>038</b>                |
|   | Clr Last       | ON / <b>OFF</b>  | Reset Fixture Last Run Time       |                                    |
|   | TempInfo       | HeadTemp   | XXX C° / F °                      | Temperature in Fixture Head        |
|   | BattInfo       | 0-100%   |                                   | Battery Charge Level               |
| Soff Ver  | V1.1.0         |  | Software Version                  |                                    |
| Persnal   | Stat Set       | Addr DMX   | ON/OFF                            | Address Via DMX                    |
|   |                | NoDMXSta   | CloShut/ <b>Hold</b> /Auto        | Auto Run If No DMX                 |
|   | Disp Set       | Off Time   | 02~59m <b>05m</b>                 | Display Shut Off Time              |
|   |                | Key Lock   | ON/ <b>OFF</b>                    | Key Lock                           |
|   | Temp C/F       | Cels/ <b>Fahren</b>                                    |                                   | Temperature Switch Between C° / F° |
|   | Man Hold       | ON/OFF   |                                   | Manual Hold                        |
|   | WDMX           | WDMXOff  |                                   |                                    |
|   |                | ActWDMX  |                                   |                                    |
|   |                | AcDaOut  |                                   |                                    |
|   |                | ClrWMX   |                                   |                                    |
| Reset Default   | ON/ <b>OFF</b> |  | Restore Factory Settings          |                                    |
| ManCntrl  | ManCntrl       | Auto, Red, Gree, Blue, Whit, Stro, Dimm, Macr, Temp... |                                   | Manual Control                     |
| Mode Set  | User Mode      | 4CH  |                                   | DMX Channel Modes                  |
|   |                | 5CH  |                                   |                                    |
|   |                | 7CH  |                                   |                                    |
|   |                | 9CH  |                                   |                                    |
| EditProg  | Sel Prog       | ProPart1 = Prog 1~10 ( <b>Program 1</b> )              |                                   | Select Programs To Be Run          |
|   |                | Pro Part2 = Prog 1~10 ( <b>Program 2</b> )             |                                   |                                    |
|   |                | Pro Part3 = Prog 1~10 ( <b>Program 3</b> )             |                                   |                                    |
|   | Edit Prog      | Prog 1   | ProgTest                          | Testing Program                    |
|   |                | :  | EdStep01=SCxxx                    | Program In Loop                    |
|   |                | Prog 10  | EdStep64=SCxxx                    | Save and Exit                      |
|   | EditScen       | Scen001<br>~<br>Scen250                                | Auto...                           | Save and Automatically Return      |
|   |                |  | --Scen Time--                     | Manual Scenes Edit                 |
| InByOut   |                |  | Stores Scenes via Ext DMX Console |                                    |
| RecCntrl  | XX~XX          |  | Automatic Scenes Recorder         |                                    |

## FuncMode

### Address

Define desired DMX address via the Control Panel.

### ValuDisp

Display DMX 512 value of each channel.

### SetSlave

Define fixture slave mode (**Slave1, Slave2, Slave3**).

### AutoProg

Define fixture mode (**Master or Alone**) for running Auto Programs. Select desired internal programs under "**Sel Prog**", set the number of steps under "**EditProg**", and edit individual scenes under "**EditScen**".

## Info

### TimeInfo

#### Cur Time

Displays fixture run time from last power ON.  
The counter is reset after each time the fixture is powered OFF.

#### TotalHrs

Displays fixture total run time.

#### Last Hrs

Displays fixture run time for a given period of time (i.e. rental period).  
This counter can be reset.

#### TimePass

Display the fixture timer password. **(038)**

#### Clr Last

Resets the last run time of the fixture.

## TempInfo

### HeadTemp

Displays temperature of the fixture.

### BattInfo

Displays the charge % level of the battery.

### Soft Ver

Displays software version of the fixture.

## Personal

### Stat Set

#### Addr DMX

When ON, define the desired DMX address via an external controller.

1. Connect the fixture to the external controller and power ON.
2. Set the DMX value of **Channel 1** on the controller to **(7)**.
3. Set the DMX value of **Channel 2** on the controller to **(7)** or **(8)**.  
When set to **(7)**, the DMX address can be set between **(1)** and **(255)**.  
When set to **(8)**, the DMX address can be set between **(256)** and **(511)**.
4. Using **Channel 3** on the controller set the desired DMX address of the fixture.

#### Example 1:

If the desired DMX address is **57**, set **Channel 1** to a value of **(7)**, set **Channel 2** to a value of **(7)**, and then set **Channel 3** to a value of **(57)**.

#### Example 2:

If the desired DMX address is **420**, set **Channel 1** to a value of **(7)**, set **Channel 2** to a value of **(8)**, and then set **Channel 3** to a value of **(164)**.  
(256+164=420)

5. After setting **Channel 3** to the desired DMX address value, wait for approximately 20 seconds for the fixture to complete the address reset function.

#### NoDMXSta

Define how fixture operates if NO DMX signal is detected.

### Disp Set

#### Off Time

Define minutes before the LCD Menu display will automatically shut OFF.

#### Key Lock

When ON, Control Panel buttons lock automatically after exiting main menu for 15 seconds. To unlock, keep **MODE/ESC** button pressed for 3 seconds.

### Temp C/F

Define how fixture displays internal temperature (Celsius or Fahrenheit).

## **Man Hold**

### **WDMX**

Control the functionality of the internal wireless WDMX receiver.

### **ResetDef**

When ON, all factory settings are restored.

## **ManCntrl**

### **ManCntrl**

Select and manually test and fine adjust each individual channel function independently from DMX control board. This function will cancel all effects, open the shutter, and the dimmer is set to 100%. With the individual functions, you can focus the light on a flat surface (wall) and perform fine adjustments.

## **Mode Set**

### **UserMode**

Select operating mode, which includes DMX Channel and User defined modes.

### **EditProg**

### **Sel Prog**

Select one of the (10) user defined internal Auto Programs.

### **EditProg**

Edit any of the (10) user defined internal Auto Programs.

### **EditScen**

Edit any of the scenes of the internal Auto Programs.

### **RecCntrl**

The fixture features an integrated DMX-recorder by which you can transmit the programmed scenes from your DMX-controller to the moving head. Adjust the desired scene numbers via the encoder (from – to). When you call up the scenes at your controller, they will automatically be transmitted to the moving head.

## EDIT PROGRAM – Record Controller – Working With Built In Programs

A Master unit can send up to 3 different data groups to the Slave units, i.e. a Master unit can start 3 different Slave units, which run 3 different programs. The Master unit sends the 3 program parts in a continuous loop.

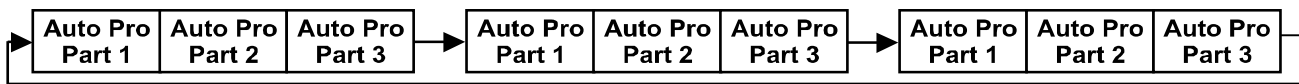

The Slave unit receives data from the Master unit according to the group which the Slave unit was assigned to. If e.g. a Slave unit is set to **“Slave 1”** in the menu **“SetSlave”**, the Master unit sends **“Prog 1”** to the Slave unit.

If set to **“Slave 2”**, the Slave unit receives **“Prog 2”**.

To start an Auto Program proceed as follows:

### 1. Slave Setting

- Select **“FuncMode”**.
- Press **ENTER** to confirm.
- Select **“SetSlave”**.
- Press **ENTER** to confirm.
- Select **“Slave 1”**, **“Slave 2”** or **“Slave 3”**.
- Press **ENTER** to confirm.
- Press **MODE/ESC** in order to return to the main menu.

### 2. Automatic Program Run

- Select **“FuncMode”**.
- Press **ENTER** to confirm.
- Select **“AutoProg”**.
- Press **ENTER** to confirm.
- Select **“Master”** or **“Alone”**.
- Press **ENTER** to confirm.
- Press **MODE/ESC** in order to return to the main menu.

## **EDIT PROGRAM – Record Controller – Working With Built-In Program [continued]**

### **3. Program Selection for Auto Pro Part**

- Select “**EditProg**”.
- Press **ENTER** to confirm.
- Select “**Sel Prog**”.
- Press **ENTER** to confirm.
- Select “**ProPart1**”, “**ProPart2**” or “**ProPart3**”, and select which Slave program is to be sent. Selection “**Prog 1**” means, that the Slave unit runs the same program as the master units.
- Press **ENTER** to confirm.
- Press **MODE/ESC** in order to return to the main menu.

### **4. Program Selection for Edit Program**

- Select “**EditProg**”.
- Press **ENTER** to confirm.
- Select the desired program. With this function you can edit specific scenes into a specific program.
- Press **ENTER** to confirm.
- Press **MODE/ESC** in order to return to the main menu.

### **5. Automatic Scene Recording**

- Select “**EditProg**”.
- Press **ENTER** to confirm.
- Select “**EditScen**”.
- Select desired scene numbers. A maximum of 250 scenes can be programmed.
- Press **ENTER** to confirm.
- Press **MODE/ESC** in order to return to the main menu.



**EDIT PROGRAM – Record Controller – Working With Built-In Program [continued]**

**Example:**

Prog 2 includes scenes: 10, 11, 12, & 13

Prog 4 includes scenes: 8, 9, & 10

Prog 6 includes scenes: 12, 13, 14, & 15

ProPart1 is Prog 2

ProPart2 is Prog 3

ProPart3 is Prog 6

The 3 Slave groups run the Auto Program in certain time segments, as shown in the following picture:

**Part 1:**

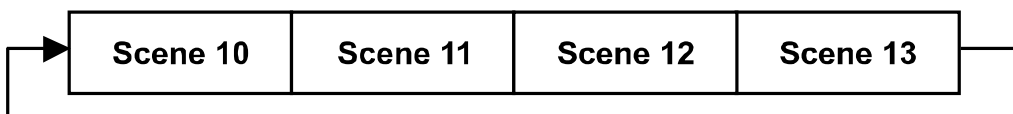

**Part 2:**

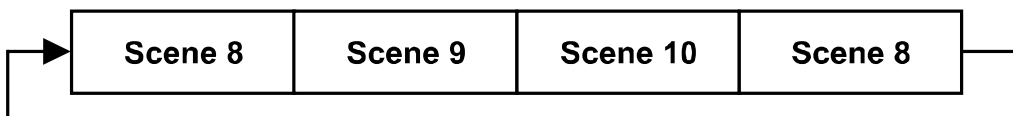

**Part 3:**

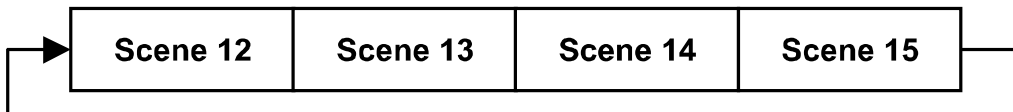

## INTERNAL WIRELESS DMX RECEIVER (EWDMX)

The **VOLT Q3™** is equipped with an internal **Elation** Wireless DMX Receiver, which is fully compatible with an **Elation** Wireless DMX System.

### WORKING WITH THE INTERNAL WIRELESS DMX (EWDMX) System

Access the “**WDMX**” sub menu from the “**PERSNAL**” menu. The “**WDMX**” sub menu allows you to “**ActWDMX**” turn the system ON, “**AcDaOut**” turn the system ON and send DMX data out through DMX OUT port, “**WDMXOff**” turn the system OFF, or “**CirWDMX**” clear the **EWDMX** system.

When the **EWDMX** system is in the “**ActWDMX**” mode, the internal DMX “**IN**” XLR jacks are turned OFF. However the internal DMX “**OUT**” XLR jacks will function normally. If the fixture is powered ON with the internal **EWDMX** system “**ActWDMX**”, it will automatically scan for a wireless DMX signal from an **Elation Wireless DMX Transmitter**. If NO wireless signal is received, it will switch to the wired DMX mode.



### W A R N I N G !

**NEVER connect a fixture to a controller via a DMX cable when the EWDMX system is in use. This could cause serious damage to the controller!!**

### SETTING UP THE EWDMX SYSTEM

Follow the instructions included with the **Elation EWDMX Transmitter** and connect it to the output of your DMX controller.

To sync your fixture with the **Elation EWDMX Transmitter** follow the steps below

- Initially, the **EWDMX** indicator on the fixture should be solid **RED**.
- Press and hold the configuration button on your **EWDMX Transmitter** for about 3 seconds. The **RED/GREEN LED** indicators on the **EWDMX Transmitter** and the fixture should then begin to flash rapidly for 5~ 10 seconds while the two systems pair.
- Once the fixture is paired with the **EWDMX Transmitter (T1)**, the **EWDMX** status indicators on the both the fixture and the **EWDMX Transmitter** will stop flashing and glow solid **GREEN**. If pairing is unsuccessful repeat the process until pairing is secured.
- The fixture will store the pairing information inside a nondestructive memory bank once a link is created between the fixture and an **EWDMX Transmitter**. The fixture will remember the paired **EWDMX Transmitter** even if the fixture is turned OFF for extended periods of time.

## CLEARING EWDMX TRANSMITTER LINK

- Access the fixture's main menu and toggle to the "**PERSNAL**" menu, then access the "**WDMX**" sub menu and select "**CirWDMX**" to clear any existing link between the fixture and a **EWDMX Transmitter**. The **EWDMX** indicator on the fixture will turn solid **RED** when the link is severed.
- You may also clear the link directly from the **EWDMX Transmitter**. First, be sure the fixture(s) is powered ON, and then hold down the configuration button on the **WDMX Transmitter** for as least 5 seconds. This will automatically clear the link between the **EWDMX Transmitter** and any fixture that is powered ON. All **EWDMX** indicators will glow solid **RED** if the procedure was successful.

## EWDMX INDICATORS

**RED/GREEN** (Rapid Flashing) = Syncing to a EWDMX Transmitter

**RED/GREEN** (Slow Flashing) = Paired with a EWDMX Transmitter but not receiving a DMX signal from a controller.

**GREEN** (Solid) = Paired with a EWDMX Transmitter and receiving DMX data

**RED** (Solid) = Not paired with a EWDMX Transmitter (FREE)

# DMX CHANNEL FUNCTIONS AND VALUES

| ELATION® VOLT Q3™  |                |      |      |         |                           |
|--|----------------|------|------|---------|---------------------------|
| DMX Channel Values / Functions (9 DMX Channels)                        |                |      |      |         |                           |
| Specifications are subject to change without any prior written notice. |                |      |      |         |                           |
| MODE / CHANNEL   |                |      |      | VALUE   | FUNCTION                  |
| 4 CH   | 5 CH           | 7 CH | 9 CH |         |                           |
| 1  | 1              | 1    | 1    |         | RED                       |
|  |                |      |      | 0-255   | Red (0-100%)              |
| 2  | 2              | 2    | 2    |         | GREEN                     |
|  |                |      |      | 0-255   | Green (0-100%)            |
| 3  | 3              | 3    | 3    |         | BLUE                      |
|  |                |      |      | 0-255   | Blue (0-100%)             |
| 4  | 4              | 4    | 4    |         | WHITE                     |
|  |                |      |      | 0-255   | White (0-100%)            |
|  |                | 5    | 5    |         | COLOR CORRECTION          |
|  |                |      |      | 0       | NO Function               |
|  |                |      |      | 1-255   | 1 = 2,700K / 255 = 7,200K |
|  |                | 6    | 6    |         | COLOR MACROS              |
|  |                |      |      | 0       | NO Function               |
|  |                |      |      | 1-7     | Color Macro 1             |
|  |                |      |      | 8-15    | Color Macro 2             |
|  |                |      |      | 16-23   | Color Macro 3             |
|  |                |      |      | 24-31   | Color Macro 4             |
|  |                |      |      | 32-39   | Color Macro 5             |
|  |                |      |      | 40-47   | Color Macro 6             |
|  |                |      |      | 48-55   | Color Macro 7             |
|  |                |      |      | 56-63   | Color Macro 8             |
|  |                |      |      | 64-71   | Color Macro 9             |
|  |                |      |      | 72-79   | Color Macro 10            |
|  |                |      |      | 80-87   | Color Macro 11            |
|  |                |      |      | 88-95   | Color Macro 12            |
|  |                |      |      | 96-103  | Color Macro 13            |
|  |                |      |      | 104-111 | Color Macro 14            |
|  |                |      |      | 112-119 | Color Macro 15            |
|  |                |      |      | 120-127 | Color Macro 16            |
|  |                |      |      | 128-135 | Color Macro 17            |
|  |                |      |      | 136-143 | Color Macro 18            |
|  |                |      |      | 144-151 | Color Macro 19            |
|  |                |      |      | 152-159 | Color Macro 20            |
|  |                |      |      | 160-167 | Color Macro 21            |
|  |                |      |      | 168-175 | Color Macro 22            |
|  |                |      |      | 176-183 | Color Macro 23            |
|  |                |      |      | 184-191 | Color Macro 24            |
|  |                |      |      | 192-199 | Color Macro 25            |
|  |                |      |      | 200-207 | Color Macro 26            |
|  |                |      |      | 208-215 | Color Macro 27            |
|  |                |      |      | 216-223 | Color Macro 28            |
|  |                |      |      | 224-231 | Color Macro 29            |
|  |                |      |      | 232-239 | Color Macro 30            |
| 240-247  | Color Macro 31 |      |      |         |                           |
| 248-255  | Color Macro 32 |      |      |         |                           |

| ELATION® VOLT Q3™  |      |      |         |                     |                                   |
|--|------|------|---------|---------------------|-----------------------------------|
| DMX Channel Values / Functions (9 DMX Channels)                        |      |      |         |                     |                                   |
| Specifications are subject to change without any prior written notice. |      |      |         |                     |                                   |
| MODE / CHANNEL   |      |      |         | VALUE               | FUNCTION                          |
| 4 CH   | 5 CH | 7 CH | 9 CH    |                     |                                   |
|  |      |      | 7       |                     | <b>COLOR CHASE MACROS</b>         |
|  |      |      |         | 0                   | NO Function                       |
|  |      |      |         | 1-30                | Chase Macro 1                     |
|  |      |      |         | 31-60               | Chase Macro 2                     |
|  |      |      |         | 61-90               | Chase Macro 3                     |
|  |      |      |         | 91-120              | Chase Macro 4                     |
|  |      |      |         | 121-150             | Chase Macro 5                     |
|  |      |      |         | 151-180             | Chase Macro 6                     |
|  |      |      |         | 181-210             | Chase Macro 7                     |
|  |      |      |         | 211-255             | Chase Macro 8                     |
|  |      |      | 8       |                     | <b>SHUTTER / STROBE</b>           |
|  |      |      |         | 0-31                | LEDs OFF                          |
|  |      |      |         | 32-63               | LEDs ON (NO STROBE)               |
|  |      |      |         | 64-95               | STROBE Effect SLOW to FAST        |
|  |      |      |         | 96-127              | LEDs ON (NO STROBE)               |
|  |      |      |         | 128-159             | STROBE Pulse Effect In Sequences  |
|  |      |      |         | 160-191             | LEDs ON (NO STROBE)               |
|  |      |      |         | 192-223             | Random STROBE Effect SLOW to FAST |
|  |      |      | 224-255 | LEDs ON (NO STROBE) |                                   |
|  | 5    | 7    | 9       |                     | <b>DIMMER INTENSITY</b>           |
|  |      |      |         | 0-255               | Intensity 0 to 100%               |

## CLEANING AND MAINTENANCE



**C A U T I O N**

**Disconnect power before cleaning or maintenance.**

### CLEANING

Frequent cleaning is recommended to insure proper function, optimized light output, and an extended life. The frequency of cleaning depends on the environment in which the fixture operates: damp, smoky or particularly dirty environments can cause greater accumulation of dirt on the fixture's optics.

- Clean the external lens surface at least every 20 days with a soft cloth to avoid dirt/debris accumulation. Never use alcohol, solvents, or ammonia based cleaners.

### MAINTENANCE

Regular inspections are recommended to insure proper function and extended life. There are no user serviceable parts inside this fixture, please refer all other service issues to an authorized Elation service technician. Should you need any spare parts, please order genuine parts from your local Elation dealer.

Please refer to the following points during routine inspections:

- A detailed electric check by an approved electrical engineer every 3 months, to make sure the circuit contacts are in good condition and prevent overheating.
- Be sure all screws and fasteners are securely tightened at all times. Loose screws may fall out during normal operation resulting in damage or injury.
- Check for any deformations on the housing, color lenses, rigging hardware and rigging points (ceiling, suspension, trussing). Deformations in the housing could allow for dust to enter into the fixture. Damaged rigging points or unsecured rigging could cause the fixture to fall and seriously injure a person(s).
- Inspect all moving parts and make sure there are no signs of wear and rotate/move without imbalances.
- Electric power supply cables must not show any damage, material fatigue or sediments. Never remove the ground prong from the power cable.

## TECHNICAL SPECIFICATIONS

### FEATURES

IP65 Rated  
7° Beam and 13° Field Angles  
180°+ Manual LED Head Positioning  
Variable Color Correction (2,700K - 7,200K)  
Internal Wireless EWDMX Receiver  
Rechargeable Lithium-Ion Battery  
Flicker Free Operation for TV and FILM  
Rugged Die-Cast Aluminum Exterior  
Rubber Padded Base and Retractable Carrying Handle

### SOURCE

(3) 15W QUAD Color RGBW LEDs  
100,000 Hour Average Life

### EFFECTS

Variable Color Correction (2,700K - 7,200K)  
Magnetic Frost Filter Gel Frame  
Electronic Strobe and Dimming  
Multiple Color and Chase Macros

### CONTROL / CONNECTIONS

(4) DMX Channel Modes (4 / 5 / 7 / 9)  
Internal Wireless EWDMX Receiver  
(4) Button Control Panel  
LCD Menu Display  
3pin IP DMX In/Out  
2pin IP Power Charger In

### SIZE / WEIGHT

Length: 9.8" (250mm)  
Width: 8.5" (215mm)  
Vertical Height: 10.9" (276mm)  
Weight: 13.0 lbs. (5.9 kg)

### ELECTRICAL / THERMAL

DC 13-17.5V  
40W Max Power Consumption (each unit)  
14°F to 113°F (-10°C to 45°C)

### INSTALLATION

Rigging: Clamps (Not Included) / Floor  
Working Position: Any (360°)

### APPROVALS / RATINGS

CE | cETLus | IP65

Please Note: Specifications and improvements in the design of this unit and this manual are subject to change without any prior written notice.

## PHOTOMETRIC DATA

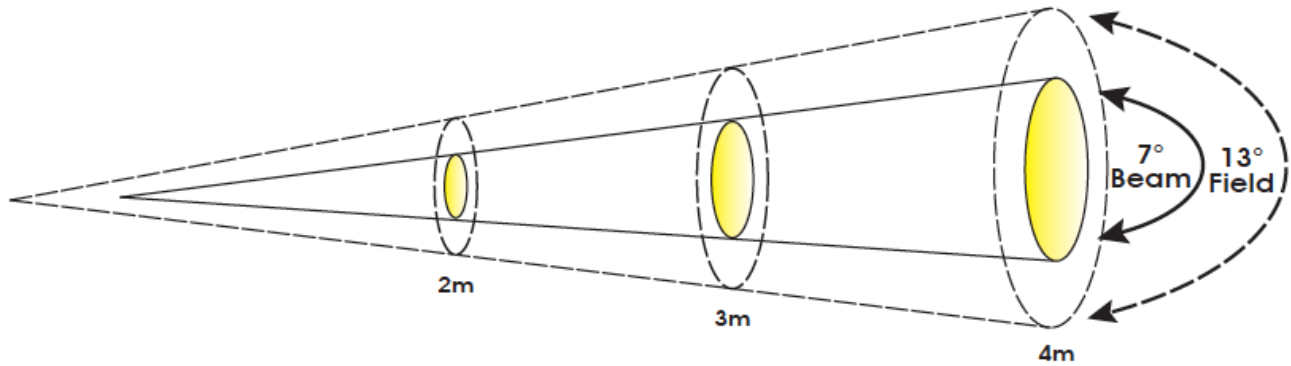

| Distance           | m     | ft  | m     | ft  | m     | ft   |
|--------------------|-------|-----|-------|-----|-------|------|
|                    | 2     | 6.6 | 3     | 9.8 | 4     | 13.1 |
| 7° Beam Diameter   | 0.26  | 0.9 | 0.38  | 1.2 | 0.51  | 1.7  |
| 13° Field Diameter | 0.47  | 1.5 | 0.68  | 2.2 | 0.92  | 3.0  |
| Photometrics       | lux   | fc  | lux   | fc  | lux   | fc   |
| RED LEDs           | 1,460 | 136 | 625   | 58  | 355   | 33   |
| GREEN LEDs         | 3,567 | 331 | 1,609 | 149 | 930   | 86   |
| BLUE LEDs          | 490   | 46  | 220   | 20  | 126   | 12   |
| WHITE LEDs         | 4,508 | 419 | 1,970 | 183 | 1,127 | 105  |
| FULL ON            | 8,920 | 829 | 3,892 | 362 | 2,193 | 204  |

Please Note: Specifications and improvements in the design of this unit and this manual are subject to change without any prior written notice.

## DIMENSIONAL DRAWINGS

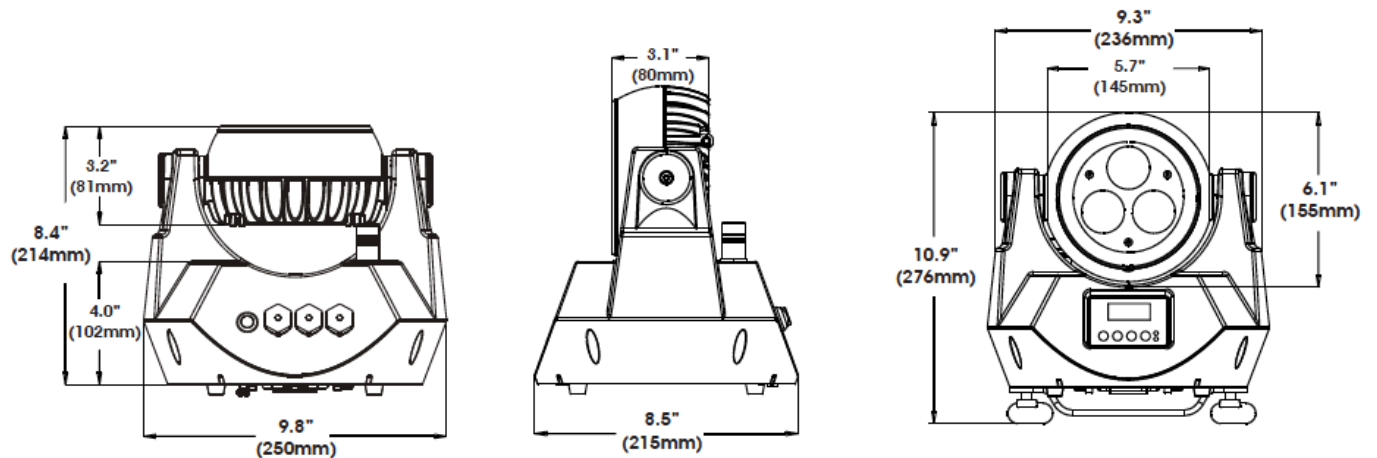

Please Note: Specifications and improvements in the design of this unit and this manual are subject to change without any prior written notice.



## OPTIONAL ACCESSORIES

| <b>ORDER CODE</b> | <b>ITEM</b>  |
|-------------------|--|
| TRIGGER CLAMP     | Heavy Duty Wrap Around Hook Style Clamp                                      |
| EWD001            | EWDMX IP Wireless IP65 DMX Transceiver                                       |
| VOLT5CHARGER      | VOLT Q3 17.5 VDC Charger + IEC Power Cable                                   |
| VOLT/3MDLC        | VOLT Series 9.8 ft. (3m) 3pin Male IP to 3pin Female IP DATA LINK Cable      |
| VOLT/DIAC         | VOLT Series 9.8 ft. (3m) 3pin IP Female to 3pin DMX Male DATA INPUT Cable    |
| VOLT/DOAC         | VOLT Series 9.8 ft. (3m) 3pin Female IP to 3pin DMX Female DATA OUTPUT Cable |

