

# **SATURA PROFILE™**

user manual

©2019 ELATION PROFESSIONAL all rights reserved. Information, specifications, diagrams, images, and instructions herein are subject to change without notice. ELATION PROFESSIONAL logo and identifying product names and numbers herein are trademarks of ELATION PROFESSIONAL. Copyright protection claimed includes all forms and matters of copyrightable materials and information now allowed by statutory or judicial law or hereinafter granted. Product names used in this document may be trademarks or registered trademarks of their respective companies and are hereby acknowledged. All non-ELATION brands and product names are trademarks or registered trademarks of their respective companies.

**ELATION PROFESSIONAL** and all affiliated companies hereby disclaim any and all liabilities for property, equipment, building, and electrical damages, injuries to any persons, and direct or indirect economic loss associated with the use or reliance of any information contained within this document, and/or as a result of the improper, unsafe, insufficient and negligent assembly, installation, rigging, and operation of this product.

**Elation Professional USA** | 6122 S. Eastern Ave. | Los Angeles, CA. 90040  
323-582-3322 | 323-832-9142 fax | [www.elationlighting.com](http://www.elationlighting.com) | [info@elationlighting.com](mailto:info@elationlighting.com)

**Elation Professional B.V.** | Junostraat 2 | 6468 EW Kerkrade, The Netherlands  
+31 45 546 85 66 | +31 45 546 85 96 fax | [www.elationlighting.eu](http://www.elationlighting.eu) | [info@elationlighting.eu](mailto:info@elationlighting.eu)

**Elation Professional Mexico** | AV Santa Ana 30 | Parque Industrial Lerma, Lerma, Mexico 52000  
+52 (728) 282-7070

## DOCUMENT VERSION

**Due to additional product features and/or enhancements, an updated version of this document may be available online.**

**Please check [www.elationlighting.com](http://www.elationlighting.com) for the latest revision/update of this manual, before beginning installation and/or programming.**

Date	Document Version	Software Version ≥	DMX Channel Modes	Notes
3/23/16	1	1.02	33 / 35 / 54	Initial release.
5/27/16	2	1.03	33 / 35 / 54	Added Fast Mode to System Menu.
7/26/16	2.2	N/C	NO CHANGE	Added Art-NET network switch note.
10/23/16	2.4	N/C	NO CHANGE	Added Gobo size details.
11/09/16	3	1.06	NO CHANGE	Added LED Refresh, Gamma, sACN.
06/22/17	3.2	1.07	NO CHANGE	Added NO ROTATION DMX values for Rotating Gobo Wheel.
04/25/18	3.4	1.0.10	NO CHANGE	Updated System Menu.
12/05/18	3.6	N/C	NO CHANGE	Updated release.
01/22/19	3.8	N/C	See Notes	Updated DMX Traits to support optional Static Gobo/Animation Wheel Kit, adding installation steps.
04/09/20	4.0	N/C	NO CHANGE	Update power consumption

# CONTENTS

General Information	4
Limited Warranty (USA Only)	5
Safety Guidelines	6
Maintenance Guidelines	8
Fixture Overview	9
Installation Guidelines	10
Optional Static Gobo Animation Wheel Installation	14
System Menu	18
DMX Channel Functions And Values	28
Error Codes	35
Specifications	37
Optional Accessories	39

# GENERAL INFORMATION

## INTRODUCTION

Please read and understand the instructions in this manual carefully and thoroughly before attempting to operate this device. These instructions contain important safety and use information.

## UNPACKING

Every device has been thoroughly tested and has been shipped in perfect operating condition. Carefully check the shipping carton for damage that may have occurred during shipping. If the carton is damaged, carefully inspect the device for damage, and be sure all accessories necessary to install and operate the device have arrived intact. In the event damage has been found or parts are missing, please contact our customer support team for further instructions. Please do not return this device to your dealer without first contacting customer support. Please do not discard the shipping carton in the trash. Please recycle whenever possible.

## BOX CONTENTS

Omega Brackets (x2)  
Locking Power Cable

## CUSTOMER SUPPORT

Contact ELATION Service for any product related service and support needs. Also visit [forums.elationlighting.com](http://forums.elationlighting.com) with questions, comments or suggestions.

**ELATION SERVICE USA - Monday - Friday 8:00am to 4:30pm PST**  
323-582-3322 | Fax 323-832-9142 | [support@elationlighting.com](mailto:support@elationlighting.com)

**ELATION SERVICE EUROPE - Monday - Friday 08:30 to 17:00 CET**  
+31 45 546 85 63 | Fax +31 45 546 85 96 | [support@elationlighting.eu](mailto:support@elationlighting.eu)

REPLACEMENT PARTS please visit [parts.elationlighting.com](http://parts.elationlighting.com)



## **I M P O R T A N T   N O T I C E !**

**THERE ARE NO USER SERVICEABLE PARTS INSIDE THIS UNIT. DO NOT ATTEMPT ANY REPAIRS YOURSELF; DOING SO WILL VOID YOUR MANUFACTURES WARRANTY. DAMAGES RESULTING FROM MODIFICATIONS TO THIS FIXTURE AND/OR THE DISREGARD OF SAFETY INSTRUCTIONS AND GUIDELINES IN THIS MANUAL VOID THE MANUFACTURES WARRANTY AND ARE NOT SUBJECT TO ANY WARRANTY CLAIMS AND/OR REPAIRS.**

## LIMITED WARRANTY (USA ONLY)

A. Elation Professional hereby warrants, to the original purchaser, Elation Professional products to be free of manufacturing defects in material and workmanship for a period of two years (730 days), and Elation Professional product rechargeable batteries to be free of manufacturing defects in material and workmanship for a period of six months (180 days), from the original date of purchase. This warranty excludes discharge lamps and all product accessories. This warranty shall be valid only if the product is purchased within the United States of America, including possessions and territories. It is the owner's responsibility to establish the date and place of purchase by acceptable evidence, at the time service is sought. B. For warranty service, send the product only to the Elation Professional factory. All shipping charges must be pre-paid. If the requested repairs or service (including parts replacement) are within the terms of this warranty, Elation Professional will pay return shipping charges only to a designated point within the United States. If any product is sent, it must be shipped in its original package and packaging material. No accessories should be shipped with the product. If any accessories are shipped with the product, Elation Professional shall have no liability what so ever for loss and/or or damage to any such accessories, nor for the safe return thereof. C. This warranty is void if the product serial number and/or labels are altered or removed; if the product is modified in any manner which Elation Professional concludes, after inspection, affects the reliability of the product; if the product has been repaired or serviced by anyone other than the Elation Professional factory unless prior written authorization was issued to purchaser by Elation Professional; if the product is damaged because not properly maintained as set forth in the product instructions, guidelines and/or user manual. D. This is not a service contract, and this warranty does not include any maintenance, cleaning or periodic check-up. During the periods as specified above, Elation Professional will replace defective parts at its expense, and will absorb all expenses for warranty service and repair labor by reason of defects in material or workmanship. The sole responsibility of Elation Professional under this warranty shall be limited to the repair of the product, or replacement thereof, including parts, at the sole discretion of Elation Professional. All products covered by this warranty were manufactured after January 1, 1990, and bare identifying marks to that effect. E. Elation Professional reserves the right to make changes in design and/or performance improvements upon its products without any obligation to include these changes in any products theretofore manufactured. F. No warranty, whether expressed or implied, is given or made with respect to any accessory supplied with the products described above. Except to the extent prohibited by applicable law, all implied warranties made by Elation Professional in connection with this product, including warranties of merchantability or fitness, are limited in duration to the warranty periods set forth above. And no warranties, whether expressed or implied, including warranties of merchantability or fitness, shall apply to this product after said periods have expired. The consumer's and/or dealer's sole remedy shall be such repair or replacement as is expressly provided above; and under no circumstances shall Elation Professional be liable for any loss and/or damage, direct and/or consequential, arising out of the use of, and/or the inability to use, this product. G. This warranty is the only written warranty applicable to Elation Professional products and supersedes all prior warranties and written descriptions of warranty terms and conditions heretofore published.

### WARRANTY RETURNS

All returned service items whether under warranty or not, must be freight pre-paid and accompany a return authorization (R.A.) number. The R.A. number must be clearly written on the outside of the return package. A brief description of the problem as well as the R.A. number must also be written down on a piece of paper and included in the shipping container. If the unit is under warranty, you must provide a copy of your proof of purchase invoice. Items returned without a R.A. number clearly marked on the outside of the package will be refused and returned at customer's expense. You may obtain a R.A. number by contacting customer support. **ONLY** Use the original packaging and materials to transport the fixture in for service.

# SAFETY GUIDELINES

This fixture is an extremely sophisticated piece of electronic equipment. To guarantee a smooth operation, it is important to follow all instructions and guidelines in this manual. The manufacturer of this device is not responsible for injury and/or damages resulting from the misuse of this fixture due to the disregard of the information printed in this manual. Only qualified and/or certified personnel should perform installation of this fixture and only the original rigging parts (omega brackets) included with this fixture should be used for installation. Any modifications to the fixture and/or the mounting hardware included will void the original manufactures warranty and increase the risk of damage and/or personal injury.



## **PROTECTION CLASS 1 - FIXTURE MUST BE PROPERLY GROUNDED**

**THERE ARE NO USER SERVICEABLE PARTS INSIDE THIS UNIT.**



**DO NOT ATTEMPT ANY REPAIRS YOURSELF; DOING SO WILL VOID YOUR MANUFACTURES WARRANTY. DAMAGES RESULTING FROM MODIFICATIONS TO THIS FIXTURE AND/OR THE DISREGARD OF SAFETY INSTRUCTIONS AND GUIDELINES IN THIS MANUAL VOID THE MANUFACTURES WARRANTY AND ARE NOT SUBJECT TO ANY WARRANTY CLAIMS AND/OR REPAIRS.**



**DO NOT PLUG FIXTURE INTO A DIMMER PACK!  
NEVER OPEN THIS FIXTURE WHILE IN USE!  
UNPLUG POWER BEFORE SERVICING FIXTURE!  
NEVER TOUCH FIXTURE DURING OPERATION, AS IT MAY BE HOT!  
KEEP FLAMMABLE MATERIALS AWAY FROM FIXTURE!**



**NEVER LOOK DIRECTLY INTO THE LIGHT SOURCE!  
RETINA INJURY RISK - MAY INDUCE BLINDNESS!  
SENSITIVE PERSONS MAY SUFFER AN EPILEPTIC SHOCK!**



**INDOOR / DRY LOCATIONS USE ONLY!  
DO NOT EXPOSE FIXTURE TO RAIN AND MOISTURE!**



**MINIMUM DISTANCE TO OBJECTS/SURFACES  
MUST BE 1.6 FEET (0.5 METERS)**

**MAXIMUM TEMPERATURE OF EXTERNAL SURFACE 185° F (85°C)**

# **S A F E T Y   G U I D E L I N E S**

**DO NOT TOUCH** the fixture housing during operation. Turn OFF the power and allow approximately 15 minutes for the fixture to cool down before serving.

**DO NOT** shake fixture, avoid brute force when installing and/or operating fixture.

**DO NOT** operate fixture if the power cord is frayed, crimped, damaged and/or if any of the power cord connectors are damaged and do not insert into the fixture securely with ease.

**NEVER** force a power cord connector into the fixture. If the power cord or any of its connectors are damaged, replace it immediately with a new one of similar power rating.

**DO NOT** block any air ventilation slots.

All fan and air inlets must remain clean and never blocked.

Allow approx. 6" (15cm) between fixture and other devices or a wall for proper cooling.

When installing fixture in a suspended environment, always use mounting hardware that is no less than M10 x 25 mm, and always install fixture with an appropriately rated safety cable.

Always disconnect fixture from main power source before performing any type of service and/or cleaning procedure. Only handle the power cord by the plug end, never pull out the plug by tugging the wire portion of the cord.

During the initial operation of this fixture, a light smoke or smell may emit from the interior of the fixture. This is a normal process and is caused by excess paint in the interior of the casing burning off from the heat associated with the lamp and will decrease gradually over time.

Consistent operational breaks will ensure fixture will function properly for many years.

# MAINTENANCE GUIDELINES



**DISCONNECT POWER BEFORE PERFORMING ANY MAINTENANCE!**

## CLEANING

Frequent cleaning is recommended to insure proper function, optimized light output, and an extended life. The frequency of cleaning depends on the environment in which the fixture operates: damp, smoky or particularly dirty environments can cause greater accumulation of dirt on the fixture's optics. Clean the external lens surface at least every 20 days with a soft cloth to avoid dirt/debris accumulation.

**NEVER** use alcohol, solvents, or ammonia-based cleaners.

## MAINTENANCE

Regular inspections are recommended to insure proper function and extended life.

There are no user serviceable parts inside this fixture, please refer all other service issues to an authorized Elation service technician. Should you need any spare parts, please order genuine parts from your local Elation dealer.

Please refer to the following points during routine inspections:

A detailed electric check by an approved electrical engineer every three months, to make sure the circuit contacts are in good condition and prevent overheating.

Be sure all screws and fasteners are securely tightened at all times. Loose screws may fall out during normal operation resulting in damage or injury as larger parts could fall.

Check for any deformations on the housing, color lenses, rigging hardware and rigging points (ceiling, suspension, trussing). Deformations in the housing could allow for dust to enter into the fixture. Damaged rigging points or unsecured rigging could cause the fixture to fall and seriously injure a person(s).

Electric power supply cables must not show any damage, material fatigue or sediments.

**NEVER** remove the ground prong from the power cable.



# FIXTURE OVERVIEW

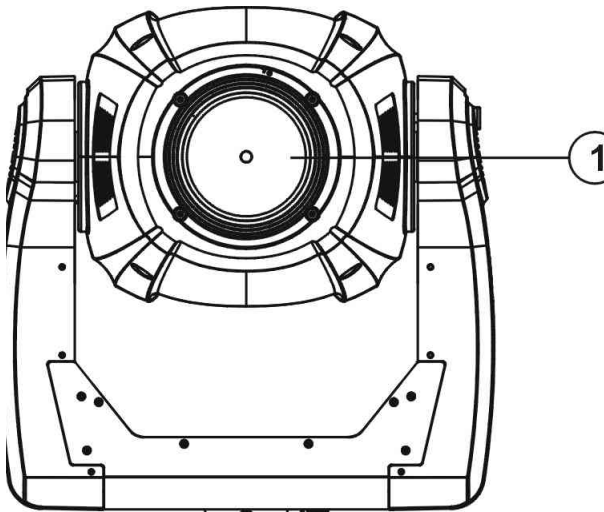

1. Lens

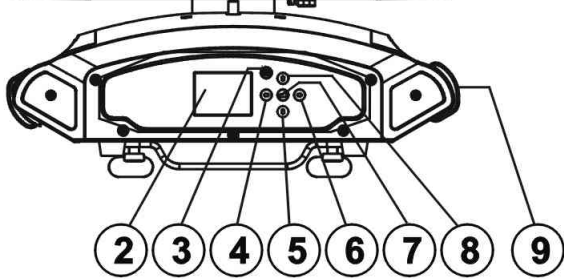

2. LCD Menu Function Display

3. MODE/ESC Button

4. LEFT Button

5. DOWN Button

6. RIGHT Button

7. ENTER Button

8. UP Button

9. Carrying Handle(s)

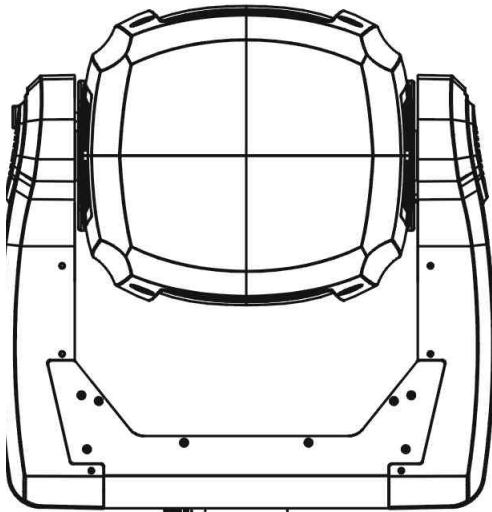

10. RJ45 Input

11. RJ45 Output

12. 3pin DMX Output

13. 3pin DMX Input

14. 5pin DMX Output

15. 5pin DMX Input

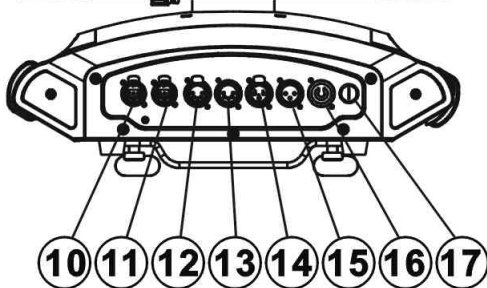

16. power Input

17. Fuse

# INSTALLATION GUIDELINES



## **FLAMMABLE MATERIAL WARNING**

Keep fixture minimum 5.0 feet (1.5m) away from flammable materials and/or pyrotechnics.



## **ELECTRICAL CONNECTIONS**

A qualified electrician should be used for all electrical connections and/or installations.



**USE CAUTION WHEN POWER LINKING OTHER MODEL FIXTURES AS THE POWER CONSUMPTION OF OTHER MODEL FIXTURES MAY EXCEED THE MAX POWER OUTPUT ON THIS FIXTURE. CHECK SILK SCREEN FOR MAX AMPS.**



**MINIMUM DISTANCE TO OBJECTS/SURFACES  
MUST BE 1.6 FEET (0.5 METERS)**



**MAXIMUM TEMPERATURE OF EXTERNAL SURFACE  
185° F (85°C)**



**DO NOT INSTALL THE FIXTURE IF YOU ARE NOT QUALIFIED TO DO SO!**

Fixture **MUST** be installed following all local, national, and country commercial electrical and construction codes and regulations.

Before rigging/mounting the fixture to any metal truss/structure or placing the fixture on any surface, a professional equipment installer **MUST** be consulted to determine if the metal truss/structure or surface is properly certified to safely hold the combined weight of the fixture, clamps, cables, and accessories.

Fixture ambient operating temperature range is **14° to 113°F. (-10° to 45°C)**

Do not use the fixture under or above this temperature.

Fixture should be installed in areas outside walking paths, seating areas, or away from areas where unauthorized personnel might reach the fixture by hand.

**NEVER** stand directly below the fixture when rigging, removing or servicing.

Overhead fixture installation must always be secured with a secondary safety attachment, such as an appropriately rated safety cable.

Allow approximately 15 minutes for the fixture to cool down before serving.

# INSTALLATION GUIDELINES

## OMEGA BRACKETS INSTALLATION

Insert the Omega Brackets into the matching holes on the bottom of the fixture. Secure the Omega Brackets to the fixture by turning each quick-lock fastener  $\frac{1}{4}$  turn clockwise; making sure the fastener is completely locked.

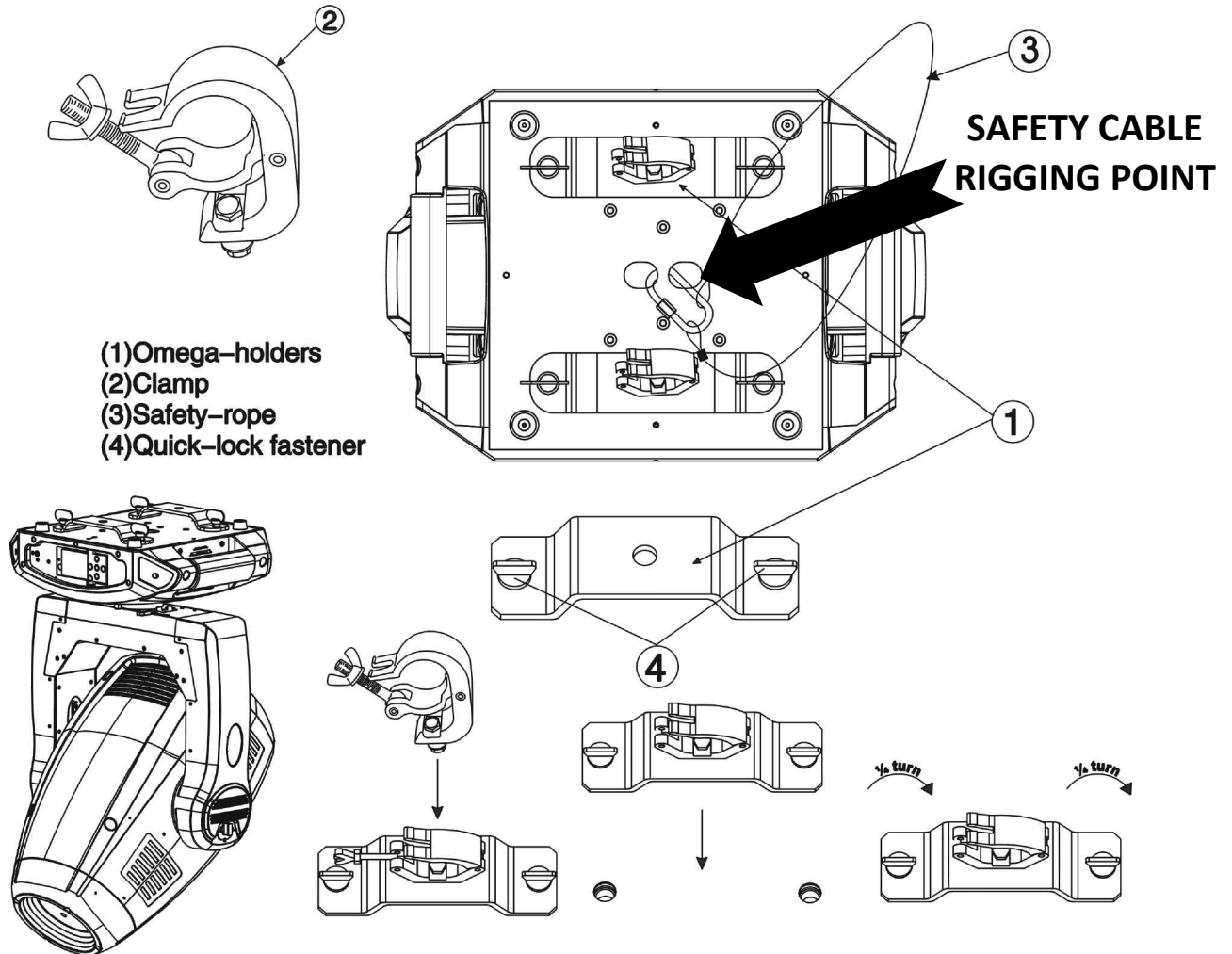

## CLAMP INSTALLATION

When mounting fixture to truss, be sure to secure an appropriately rated professional grade rigging clamp to the included **Omega Brackets** using an M10 screw fitted through the center hole of the **Omega Brackets**. The fixture provides a built-in rigging point for a **SAFETY CABLE**. Be sure to only use the designated rigging point for the safety cable and never secure a safety cable to a carrying handle.

# INSTALLATION GUIDELINES

## RIGGING

Overhead rigging requires extensive experience, including amongst others calculating working load limits, installation material being used, and periodic safety inspection of all installation material and the fixture. If you lack these qualifications, do not attempt the installation yourself. Improper installation can result in bodily injury. Fixture is fully operational in the specific mounting positions illustrated below.



**SIDE MOUNTING IS NOT PERMITTED**

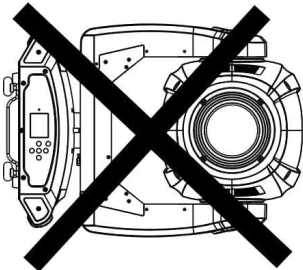
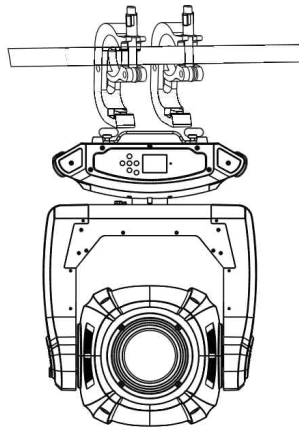

**SAFETY CABLE**  
**ALWAYS ATTACH A SAFETY CABLE WHENEVER**  
**INSTALLING THIS FIXTURE IN A SUSPENDED**  
**ENVIRONMENT TO ENSURE THE FIXTURE WILL**  
**NOT DROP IF THE CLAMP FAILS.**

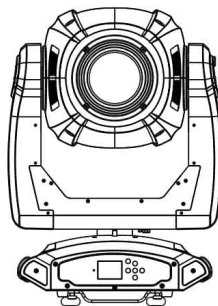

## ART-NET CONNECTION

When connecting fixture to a network switch to control multiple devices, a **Gigabit Ethernet Switch** that supports **IGMP (Internet Group Management Protocol)** is required. Using a **Gigabit Ethernet Switch** that does not support **IGMP** can cause erratic behavior of all connected devices to the switch.

Click link below for more information about IGMP.

[https://en.wikipedia.org/wiki/Internet\\_Group\\_Management\\_Protocol](https://en.wikipedia.org/wiki/Internet_Group_Management_Protocol)

# INSTALLATION GUIDELINES

## POTENTIAL INTERNAL FIXTURE DAMAGE FROM EXTERNAL SOURCES OF LIGHT BEAMS

External sources of light beams from direct sunlight, lighting moving head fixtures, and lasers, which are focused directly towards the exterior housing and/or penetrate the front lens opening of ELATION lighting fixtures, can cause severe internal damage including burning to optics, dichroic color filters, glass and metal gobos, prisms, animation wheels, frost filters, iris, shutters, motors, belts, wiring, discharge lamps, and LEDs.

This issue is not specific only to ELATION lighting fixtures, it is a common issue with lighting fixtures from all manufacturers. Although there is no true way to fully prevent this issue from happening, the guidelines below can prevent any potential damage from occurring if followed. Contact ELATION Service for more details.

**DO NOT EXPOSE THE FIXTURE AND/OR FRONT LENS OPENING TO LIGHT BEAMS FROM DIRECT SUNLIGHT, OTHER LIGHTING MOVING HEAD FIXTURES, AND LASERS WHILE UNPACKING, INSTALLATION, USE, AND EXTENDED IDLE TIMES OUTDOORS.**  
**DO NOT FOCUS A LIGHT BEAM FROM ONE LIGHTING FIXTURE DIRECTLY TOWARDS ANOTHER.**

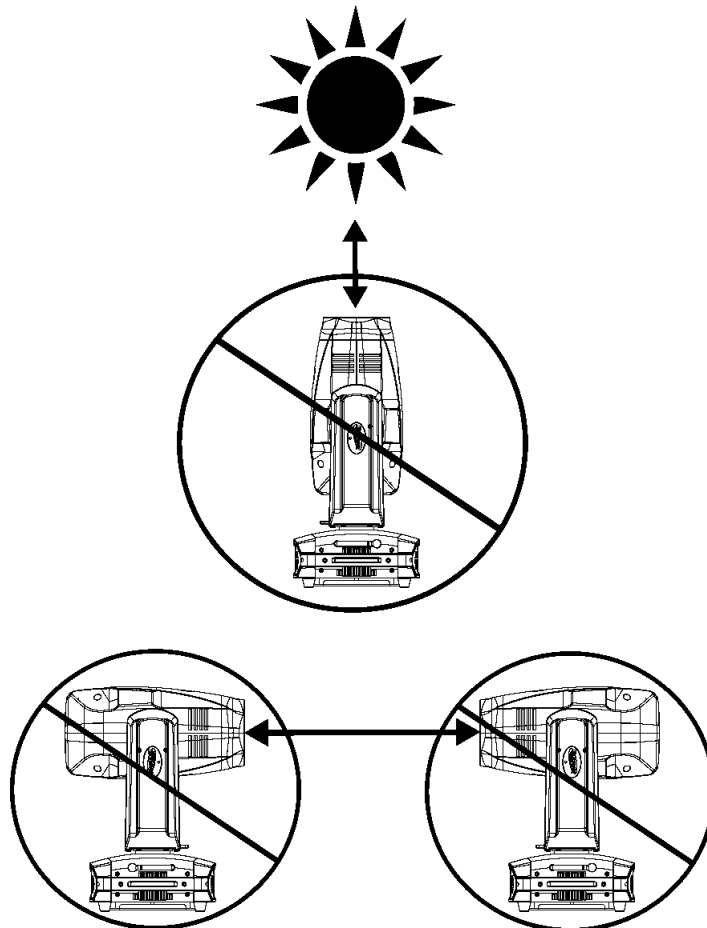

## OPTIONAL STATIC GOBO ANIMATION WHEEL INSTALLATION



1. Place fixture on a flat surface and lock head in an upright position with TILT lock engaged.



2. Remove (2x) Phillips screws securing top and bottom head panel covers, remove both covers.

## OPTIONAL STATIC GOBO ANIMATION WHEEL INSTALLATION

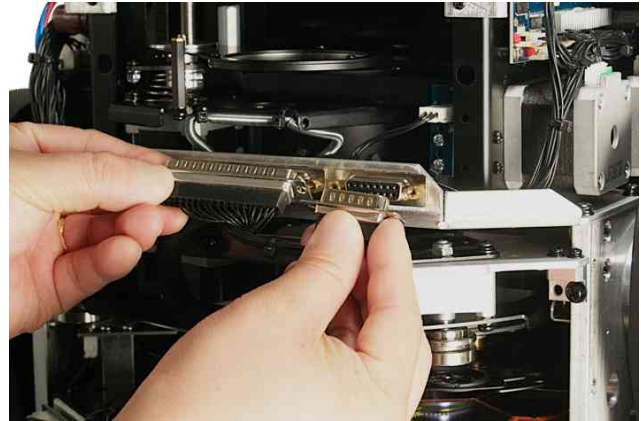
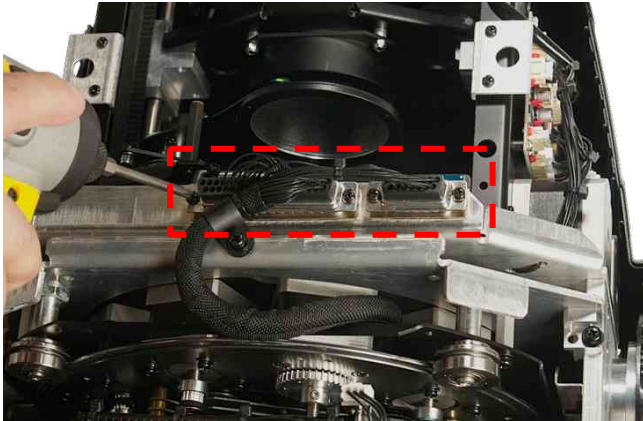

3. Remove (4x) #2 Philips screws securing 2 wire harness connectors, then carefully unplug both connectors.



4. Remove (2x) #2 Philips screws securing the effect module.

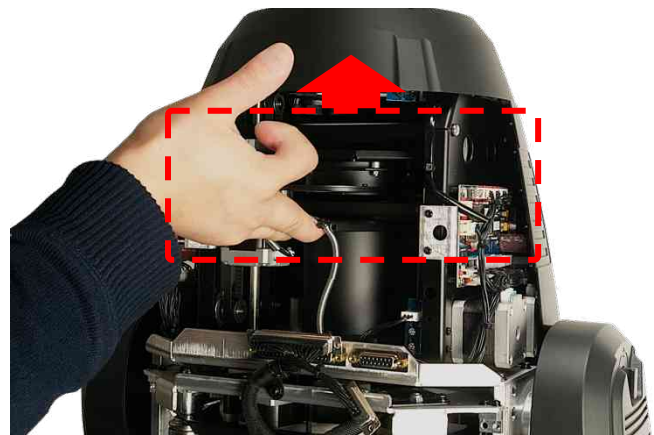

5. Because the internal lens assembly passes through the effect module tray, it needs to be lifted out and away from the effect module in order to remove it.

## OPTIONAL STATIC GOBO ANIMATION WHEEL INSTALLATION

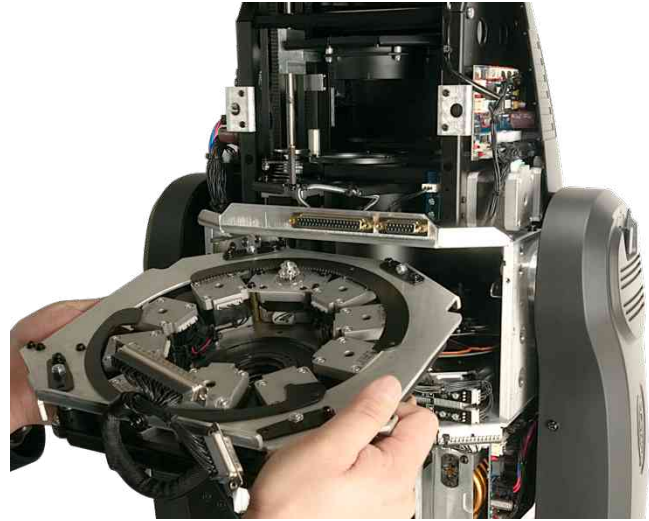
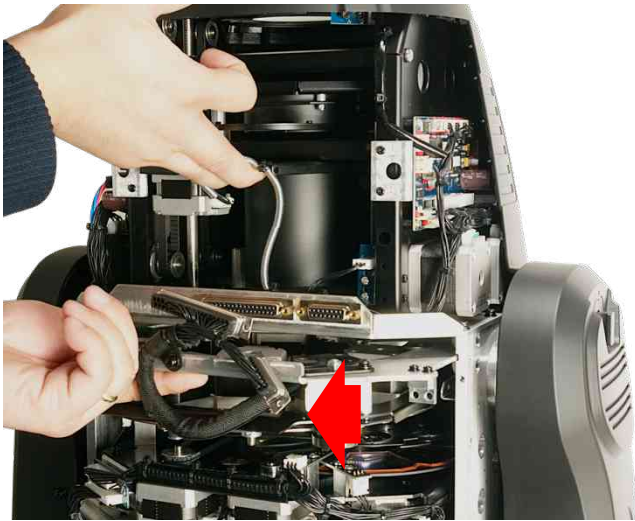

6. With the internal lens assembly lifted, carefully remove the effect module from fixture.

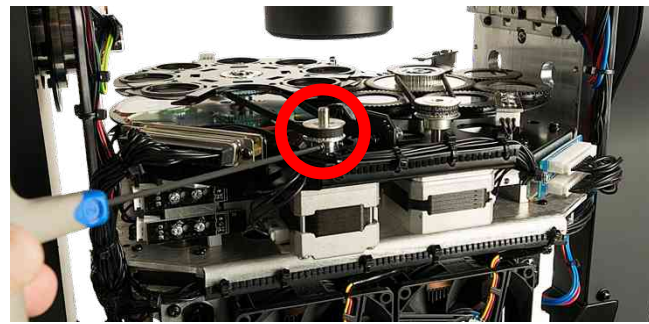
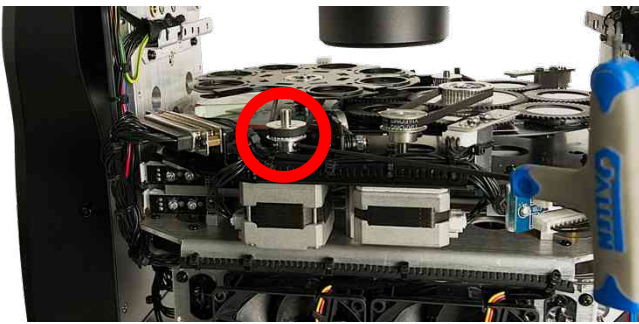

7. Loosen (2x) #2 Allen set-screws securing the belt gear spindle. This will reduce the belt tension on the Static Gobo wheel gear spindle.



8. Loosen (2x) #2 Allen set-screws on the Static Gobo wheel gear spindle (located between the Static Gobo wheel and the Color wheel).



## OPTIONAL STATIC GOBO ANIMATION WHEEL INSTALLATION

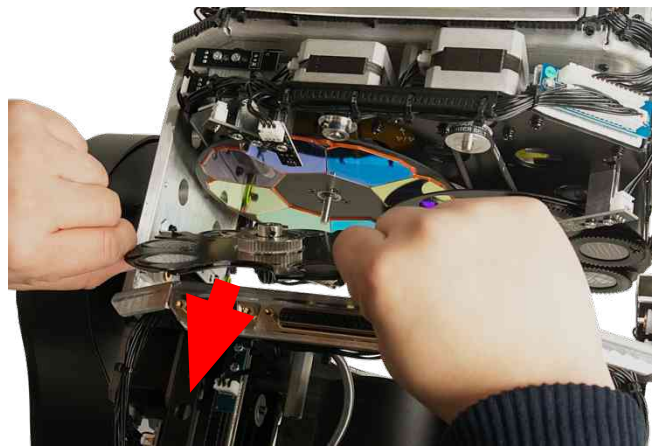

9. Because the internal lens assembly impedes the removal path of the Static Gobo wheel, disengage the TILT lock and invert the head. This will lower the internal lens assembly out and away, providing a clear path to remove the Static Gobo wheel.



10. If using any of the stock Gobos, carefully remove them from the Static Gobo wheel.



11. Carefully insert the desired Static Metal Gobos into the new Gobo/Animation wheel, making sure each of the 4 Static Metal Gobos are securely in place before installing Gobo/Animation wheel into the fixture. Reverse instructions to complete installation.

# SYSTEM MENU

The fixture includes an easy to navigate system menu. The control panel (see image below) located on the front of the fixture, provides access to the main system menu and is where all necessary system adjustments are made to the fixture. During normal operation, pressing **MODE/ESC** button once will access the fixture's main menu. Once in the main menu you can navigate through the different functions and access the sub-menus with the **UP, DOWN, RIGHT, and LEFT** buttons. Once you reach a field that requires adjusting, press the **ENTER** button to activate that field and use the **UP** and **DOWN** buttons to adjust the field. Pressing the **ENTER** button once more will confirm your setting. You may exit the main menu at any time without making any adjustments by pressing the **MODE/ESC** button.

To access the LCD Menu Control Display via the internal battery, press and hold the **MODE/ESC** button for 3 seconds. The LCD Menu Control Display will shut **OFF** automatically about 1 minute from the last button press.

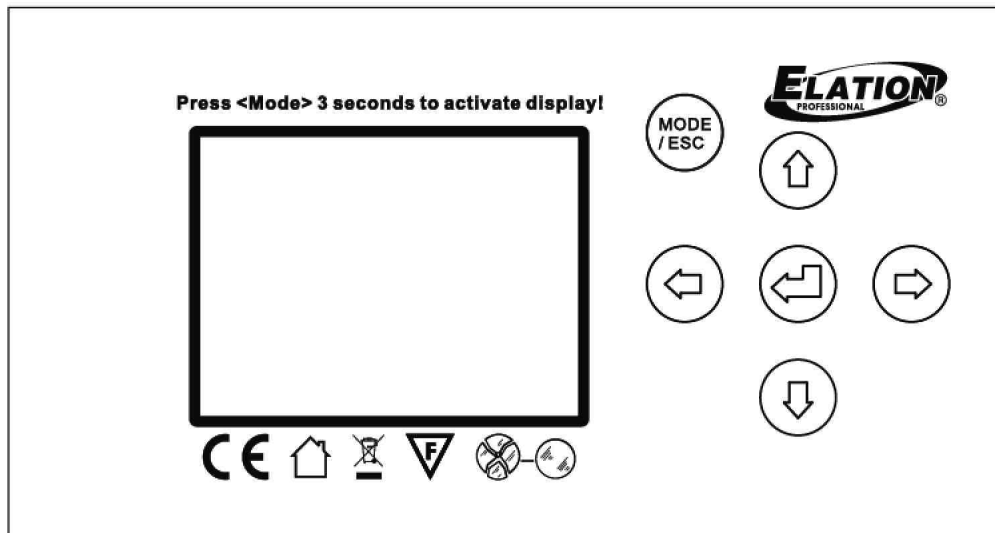

## ELATION SATURA PROFILE SYSTEM MENU

Supports Software Versions: ≥ 1.0.2

Features are subject to change without any prior written notice.

MAIN MENU	SUB MENU	OPTIONS / VALUES (Default Settings in <b>BOLD</b> )		DESCRIPTION
FUNCTION	Set Dmx Address	A001~AXXX		DMX Address Setting
	Dmx Value	ALL.....		DMX Value Display
	Slave Mode	Slave1, Slave2, Slave3		Slave Setting
	Auto Program	Master / Alone		Auto Program
INFORMATION	Time Information	Current Time	XXXX (Hours)	Fixture Run Time From Power ON
		Total Run Time	XXXX (Hours)	Fixture Total Run Time
		Last Run Time	XXXX (Hours)	Clear Fixture Last Run Time
		LastRun Password	Password=XXX	Password <b>038</b>
		Clear Last Run	ON / <b>OFF</b>	Clear Fixture Last Run Time
	Temperature Info	Head Temperature	XXX C° / F°	Temperature in Fixture Head
	Ethernet IP	XXX.XXX.XXX.XXX		Fixture IP Address
		XXX.XXX.XXX.XXX		
	Fan Speed	1U_Fan1: ~ 5U_Fan2:	XXX RPM	Fan Speeds
	Software Version	1U01: - 7U01:	≥V1.0.2	Software Version
Error Info	Error Record 1 ~ Error Record 10		Pan....	
PERSONALITY	Status Settings	Address via DMX	<b>ON/OFF</b>	Address Via DMX
		No DMX Status	Close Shutter / <b>Hold</b> / Auto Program	Auto Run If No DMX
		Pan Reverse	<b>ON/OFF</b>	Pan Reverse Movement
		Tilt Reverse	<b>ON/OFF</b>	Tilt Reverse Movement
		Pan Degree	630/540	Pan Degree Select
		Feedback	<b>ON/OFF</b>	Movement Feedback
		Movement Speed	Speed <b>1</b> ~ 4	Movement Mode Select
		Hibernation	OFF, 01M~99M, <b>15M</b>	Stand By Mode
		Dimmer Mode	<b>Standard</b> , Stage, TV, Architectural, Theatre	Set Dimmer Curve Mode
	Service Setting	Password	Password= <b>050</b>	Service Password
		RDM PID	<b>XXXXX</b>	RDM PID Code ( <b>PSWD Required</b> )
		Ethernet IP	XXX . XXX . XXX . XXX	Ethernet IP ( <b>PSWD Required</b> )
		Ethernet Mask IP	XXX . XXX . XXX . XXX	Ethernet Mask IP ( <b>PSWD Required</b> )
		Clear Err. Info	<b>ON/OFF</b>	Clear Error Info ( <b>PSWD Required</b> )
	Fans Control	<b>Auto</b> , Silent		Select Fans Mode
	Display Setting	Shutoff Time	02~60m <b>05m</b>	Display Shut Off Time
		Display Reverse	<b>ON/OFF</b>	Display Reverse 180°
		Key Lock	<b>ON/OFF</b>	Key Lock
	Temperature C/F	<b>Celsius/Fahrenheit</b>		Temperature Switch Between C° / F°
	Initial Status	PAN =XXX		Initial Effect Position
	Select Signal	<b>DMX Only</b>		DMX Only
		Art-Net on IP2		Select Art-Net IP02
		Art-Net on IP10		Select Art-Net IP010
	Set Universe	<b>000</b> - 255		Set ArtNet Universe
	Reset Default	<b>ON/OFF</b>	Password = <b>011</b>	Restore Factory Settings ( <b>PSWD Required</b> )

### SYSTEM MENU CHANGE WITH SOFTWARE UPDATE VERSION ≥1.0.3

See highlighted menu items below which have been updated with this software update.

PERSONALITY	Status Settings	Fast Mode	ON/OFF	Fast Mode Select
-------------	-----------------	-----------	--------	------------------

### SYSTEM MENU CHANGE WITH SOFTWARE UPDATE VERSION ≥1.0.6

See highlighted menu items below which have been updated with this software update.

PERSONALITY	Refresh	1200, 900-1500, 2500, 4000, 5000, 10000, 15000, 20000, 25000 (Hz)	Refresh Frequency Rate Setting
	Gamma	Gama = <b>2.0</b> , 2.2, 2.4, 2.8	Gamma Setting
	Select Signal	<b>DMX Only</b>	DMX Only
		Art-Net on IP2	Select Art-Net IP02
		Art-Net on IP10	Select Art-Net IP010
	sACN	Select sACN	

ELATION© SATURA PROFILE				
SYSTEM MENU				
Supports Software Versions: ≥ 1.0.2				
Features are subject to change without any prior written notice.				
MAIN MENU	SUB MENU	OPTIONS / VALUES (Default Settings in BOLD)	DESCRIPTION	
Reset Function	Reset All		Reset All Motors	
	Reset Pan&Tilt		Reset Pan/Tilt	
	Reset Colors		Reset Color Wheel	
	Reset Gobos		Reset Gobos	
	Reset Others		Reset Other Motors	
Effect Adjust	Test Channel	PAN .....	Test function	
	Manual Control	PAN =XXX, .....	Fine Adjustments	
	Calibration	Calibration Password	Password <b>050 (PSWD Required)</b>	
User Mode Set	User Mode	<b>Standard Mode</b>	DMX Channel Modes	
		Basic Mode		
		Extended Mode		
		User Mode A	User Defined Channel Assignment	
		User Mode B		
	User Mode C			
	Edit User Mode	Edit User Mode A	Max Channel = XX	Edits User Defined Channel Assignments
Edit User Mode B				
Edit User Mode C		PAN = CH01		
Edit Program	Select Program	Auto Pro Part1 = Program 1~10 ( <b>Program 1</b> )	Select Programs To Be Run	
		Auto Pro Part2 = Program 1~10 ( <b>Program 2</b> )		
		Auto Pro Part3 = Program 1~10 ( <b>Program 3</b> )		
	Edit Program	Program 1	Program Test	Testing Program
		:	Step 01=SCxxx	Program In Loop
		Program 10	Step 64=SCxxx	Save and Exit
	Edit Scenes	Scene 001 ~ Scene 250	Pan,Tilt,.....	Save and Automatically Return
			--Fade Time-- --Scene Time--	Manual Scenes Edit
			Input By Outside	Stores Scenes via Ext DMX Console
Rec. Controller	XX~XX		Automatic Scenes Recorder	

## SYSTEM MENU CHANGE WITH SOFTWARE UPDATE VERSION ≥1.0.10

See highlighted menu items below which have been updated with this software update.

Features are subject to change without any prior written notice.				
MAIN MENU	SUB MENU	OPTIONS / VALUES (Default Settings in <b>BOLD</b> )		DESCRIPTION
FUNCTION	Set Dmx Address	A001~AXXX		DMX Address Setting
	Dmx Value	ALL.....		DMX Value Display
	Slave Mode	Slave1, Slave2, Slave3		Slave Setting
	Auto Program	Master / Alone		Auto Program
INFORMATION	Time Information	Current Time	XXXX (Hours)	Fixture Run Time From Power ON
		Total Run Time	XXXX (Hours)	Fixture Total Run Time
		Last Run Time	XXXX (Hours)	Clear Fixture Last Run Time
		LastRun Password	Password=XXX	Password <b>038</b>
		Clear Last Run	ON / <b>OFF</b>	Clear Fixture Last Run Time
	Temperature Info	Head Temperature	XXX C° / <b>F</b> °	Temperature in Fixture Head
	Ethernet IP	XXX.XXX.XXX.XXX		Fixture IP Address
		XXX.XXX.XXX.XXX		
	Fan Speed	1U_Fan1: ~ 5U_Fan2:	XXX RPM	Fan Speeds
Software Version	1U01: - 7U01:	≥V1.0.10	Software Version	
Error Info	Error Record 1 ~ Error Record 10		Pan....	
PERSONALITY	Status Settings	Address via DMX	<b>ON/OFF</b>	Address Via DMX
		No DMX Status	Close Shutter / <b>Hold</b> / Auto Program	Auto Run If No DMX
		Pan Reverse	<b>ON/OFF</b>	Pan Reverse Movement
		Tilt Reverse	<b>ON/OFF</b>	Tilt Reverse Movement
		Pan Degree	630/ <b>540</b>	Pan Degree Select
		Feedback	<b>ON/OFF</b>	Movement Feedback
		Movement Speed	Speed <b>1</b> ~ 4	Movement Mode Select
		Fast Mode	<b>ON/OFF</b>	Fast Mode Select
		Hibernation	OFF, 01M~99M, <b>15M</b>	Stand By Mode
	Service Setting	Password	Password= <b>050</b>	Service Password
		RDM PID	<b>XXXXX</b>	RDM PID Code ( <b>PSWD Required</b> )
		Ethernet IP	XXX . XXX . XXX . XXX	Ethernet IP ( <b>PSWD Required</b> )
		Ethernet Mask IP	XXX . XXX . XXX . XXX	Ethernet Mask IP ( <b>PSWD Required</b> )
		Clear Err. Info	<b>ON/OFF</b>	Clear Error Info ( <b>PSWD Required</b> )
	Fans Control	<b>Auto</b> , Silent		Select Fans Mode
	Display Setting	Shutoff Time	02~60m <b>05m</b>	Display Shut Off Time
		Display Reverse	<b>ON/OFF</b>	Display Reverse 180°
		Key Lock	<b>ON/OFF</b>	Key Lock
	Temperature C/F	<b>Celsius/Fahrenheit</b>		Temperature Switch Between C°/ F°
	Initial Status	PAN =XXX		Initial Effect Position
	Refresh	1200, 900-1500, 2500, 4000, 5000, 10000, 15000, 20000, 25000 (Hz)		Refresh Frequency Rate Setting
	Gamma	Gama = <b>2.0</b> , 2.2, 2.4, 2.8		Gamma Setting
	Select Signal	<b>DMX Only</b>		DMX Only
		Art-Net		Select Art-Net
		sACN		Select sACN
	Set Universe	<b>000</b> - 32767		Set ArtNet Universe
	Reset Default	<b>ON/OFF</b>	Password= <b>011</b>	Restore Factory Settings ( <b>PSWD Required</b> )

**Supports Software Versions: ≥ 1.0.10**

Features are subject to change without any prior written notice.

<b>MAIN MENU</b>	<b>SUB MENU</b>	<b>OPTIONS / VALUES</b> (Default Settings in <b>BOLD</b> )		<b>DESCRIPTION</b>	
Reset Function	Reset All			Reset All Motors	
	Reset Pan&Tilt			Reset Pan/Tilt	
	Reset Colors			Reset Color Wheel	
	Reset Gobos			Reset Gobos	
	Reset Others			Reset Other Motors	
Effect Adjust	Test Channel	PAN .....		Test function	
	Manual Control	PAN =XXX, .....		Fine Adjustments	
	Calibration	Calibration Password		Password <b>050 (PSWD Required)</b>	
User Mode Set	User Mode	<b>Standard Mode</b>		DMX Channel Modes	
		Basic Mode			
		Extended Mode			
		User Mode A		User Defined Channel Assignment	
		User Mode B			
	User Mode C				
	Edit User Mode	Edit User Mode A	Max Channel = XX		Edits User Defined Channel Assignments
Edit User Mode B					
Edit User Mode C		PAN = CH01			
Edit Program	Select Program	Auto Pro Part1 = Program 1~10 ( <b>Program 1</b> )		Select Programs To Be Run	
		Auto Pro Part2 = Program 1~10 ( <b>Program 2</b> )			
		Auto Pro Part3 = Program 1~10 ( <b>Program 3</b> )			
	Edit Program	Program 1	Program Test		Testing Program
		:	Step 01=SCxxx		Program In Loop
		Program 10	Step 64=SCxxx		Save and Exit
	Edit Scenes	Scene 001 ~ Scene 250	Pan,Tilt,.....		Save and Automatically Return
			--Fade Time-- --Scene Time--		Manual Scenes Edit
			Input By Outside		Stores Scenes via Ext DMX Console
	Rec. Controller	XX~XX			Automatic Scenes Recorder

## **FUNCTION - Auto Program**

Define fixture mode (**Master or Alone**) for running Auto Programs. Select desired internal programs under “**Select Program**”, set the number of steps under “**Edit Program**”, and edit individual scenes under “**Edit Scenes**”.

## **PERSONALITY - Status Settings - Address Via DMX**

When ON, define the desired DMX address via an external controller.

**NOTE: This process assumes the fixture DMX address is set to 001. If fixture DMX address is not at 001, you must adjust the channel numbers accordingly in order for this feature to work.**

**For example: if your fixture address is 010, then Channel 1 becomes Channel 10, Channel 2 becomes Channel 11, and Channel 3 becomes Channel 12.**

1. Connect the fixture to the external controller and power ON.
2. Set the DMX value of **Channel 1** on the controller to **(7)**.
3. Set the DMX value of **Channel 2** on the controller to **(7)** or **(8)**.  
When set to **(7)**, the DMX address can be set between **(1)** and **(255)**.  
When set to **(8)**, the DMX address can be set between **(256)** and **(511)**.
4. Using **Channel 3** on the controller set the desired DMX address of the fixture.

### **Example 1:**

If the desired DMX address is **57**, set **Channel 1** to a value of **(7)**, set **Channel 2** to a value of **(7)**, and then set **Channel 3** to a value of **(57)**.

### **Example 2:**

If the desired DMX address is **420**, set **Channel 1** to a value of **(7)**, set **Channel 2** to a value of **(8)**, and then set **Channel 3** to a value of **(164)**. (256+164=420)

5. After setting **Channel 3** to the desired DMX address value, wait for approximately 20 seconds for the fixture to complete the address reset function.

## **PERSONALITY – Service Setting – Password (050)**

**NOTE: The Service Password MUST be entered in order to access the following menus: RDM PID, Ethernet IP, Ethernet IP Mask, and Clear Err. Info.**

## **PERSONALITY – Service Setting - RDM PID**

Select various submenus via RDM.

RDM stands for "Remote Device Management", which provides the ability to control the device remotely while connected to a DMX-bus. ANSI E1.20-2006 by ESTA specifies the RDM standard as an extension of the DMX512 protocol. Manual settings like adjusting the DMX starting address are no longer needed. This is especially useful when the device is installed in a remote area.

RDM ready and conventional DMX devices can be operated in one DMX line. The RDM protocol sends its own packages in the DMX512 data feed and does not influence conventional devices. If DMX splitters are used and RDM control is to be used, these splitters must support RDM. The number and type of RDM parameters depend on the RDM controller being used.

## **PERSONALITY - Display Setting – Key Lock**

When ON, Control Panel buttons lock automatically after exiting main menu for 15 seconds. To unlock, keep **MODE/ESC** button pressed for 3 seconds.

## **EFFECT ADJUST – Test Channel**

Select and auto test each individual channel function independently from the DMX control board.

## **EFFECT ADJUST – Manual Control**

Select and manually test and fine adjust each individual channel function independently from DMX control board. This function will center PAN and TILT motors and set dimmer to 100%. PAN and TILT functions will still operate if the fixture needs to be positioned to a flat clear surface. With the individual functions, you can focus the light on a flat surface (wall) and perform fine adjustments.

## **EFFECT ADJUST – Calibration**



**ONLY QUALIFIED TECHNICIANS SHOULD PERFORM THIS FUNCTION.**

This function allows small adjustments to be made to the effect wheels (Color, Gobo, Shutter, etc.) to compensate for wear or in the event a sensor has been knocked slightly out of place. Because improper use of this function can result in undesired operation this function has been password protected. The password is **050** and must be entered each time the calibration menu function is entered. Because calibration is an extremely delicate procedure, instructions on performing this action are left out of this manual. For a first time calibrator, please contact our customer support team for step-by-step instructions.



## **USER MODE SET – Edit User Mode**

Create user defined channel orders allowing the fixture to match the channel order of other fixtures on the market for easier operation. A total of three user modes may be configured: User Mode A, User Mode B, and User Mode C.

## **EDIT PROGRAM – Rec. Controller**

The fixture features an integrated DMX-recorder by which you can transmit the programmed scenes from your DMX-controller to the moving head. Adjust the desired scene numbers via the encoder (from – to). When you call up the scenes at your controller, they will automatically be transmitted to the moving head.

## **EDIT PROGRAM – Record Controller – Working With Built In Programs**

A Master unit can send up to 3 different data groups to the Slave units, i.e. a Master unit can start 3 different Slave units, which run 3 different programs. The Master unit sends the 3 program parts in a continuous loop.

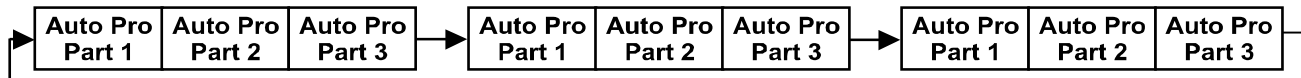

The Slave unit receives data from the Master unit according to the group which the Slave unit was assigned to. If e.g. a Slave unit is set to **“Slave 1”** in the menu **“Set to Slave”**, the Master unit sends **“Auto Program Part 1”** to the Slave unit.

If set to **“Slave 2”**, the Slave unit receives **“Auto Program Part 2”**.

To start an Auto Program proceed as follows:

### **1. Slave Setting**

- Select **“Function Mode”**.
- Press **ENTER** to confirm.
- Select **“Set to Slave”**.
- Press **ENTER** to confirm.
- Select **“Slave 1”**, **“Slave 2”** or **“Slave 3”**.
- Press **ENTER** to confirm.
- Press **MODE/ESC** in order to return to the main menu.

## **EDIT PROGRAM – Record Controller – Working With Built-In Program [continued]**

### **2. Automatic Program Run**

- Select “**Function Mode**”.
- Press **ENTER** to confirm.
- Select “**Auto Program**”.
- Press **ENTER** to confirm.
- Select “**Master**” or “**Alone**”.
- Press **ENTER** to confirm.
- Press **MODE/ESC** in order to return to the main menu.

### **3. Program Selection for Auto Pro Part**

- Select “**Edit Program**”.
- Press **ENTER** to confirm.
- Select “**Select Programs**”.
- Press **ENTER** to confirm.
- Select “**Auto Pro Part 1**”, “**Auto Pro Part 2**” or “**Auto Pro Part 3**”, and select which Slave program is to be sent. Selection “**Part 1**” means, that the Slave unit runs the same program as the master units.
- Press **ENTER** to confirm.
- Press **MODE/ESC** in order to return to the main menu.

### **4. Program Selection for Edit Program**

- Select “**Edit Program**”.
- Press **ENTER** to confirm.
- Select “**Edit Program**”.
- Press **ENTER** to confirm.
- Select the desired program. With this function you can edit specific scenes into a specific program.
- Press **ENTER** to confirm.
- Press **MODE/ESC** in order to return to the main menu.

## **EDIT PROGRAM – Record Controller – Working With Built-In Program [continued]**

### **5. Automatic Scene Recording**

- Select **“Edit Program”**.
- Press **ENTER** to confirm.
- Select **“Edit Scenes”**.
- Select desired scene numbers. A maximum of 250 scenes can be programmed.
- Press **ENTER** to confirm.
- Press **MODE/ESC** in order to return to the main menu.

#### **Example:**

Program 2 includes scenes: 10, 11, 12, & 13

Program 4 includes scenes: 8, 9, & 10

Program 6 includes scenes: 12, 13, 14, & 15

Auto Pro Part 1 is Program 2

Auto Pro Part 2 is Program 3

Auto Pro Part 3 is Program 6

The 3 Slave groups run the Auto Program in certain time segments, as shown in the following picture:

#### **Part 1:**

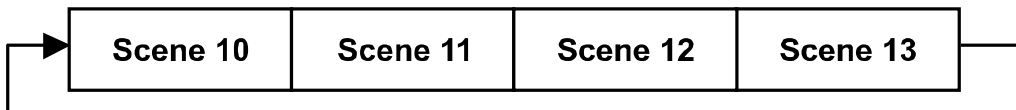

#### **Part 2:**

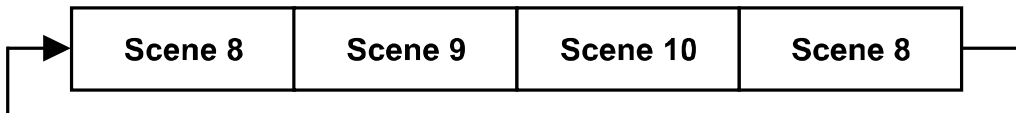

#### **Part 3:**

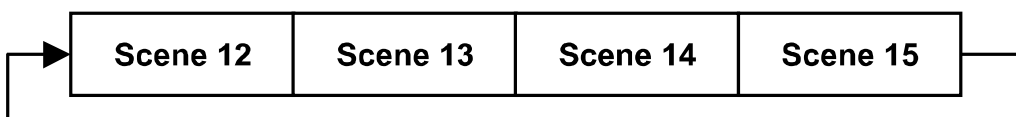

# DMX CHANNEL FUNCTIONS AND VALUES

## RELATION SATURA PROFILE™

DMX Channel Values / Functions (54 DMX Channels)

Supports Software Versions: ≥ 1.0.2

**Features are subject to change without any prior written notice.**

\*Rotation direction (Clockwise or Counterclockwise) of effects depends on orientation of the fixture head and Pan/Tilt settings.

MODE / CHANNEL			VALUE	FUNCTION
BASIC	STAND	EXTEND		
1	1	1		PAN MOVEMENT [8 BIT]
			0-255	PAN Movement
	2	2		PAN FINE MOVEMENT [16 BIT]
			0-255	Fine Control of PAN Movement
2	3	3		TILT MOVEMENT [8 BIT]
			0-255	TILT Movement
	4	4		TILT MOVEMENT [16 BIT]
			0-255	Fine Control of TILT Movement
3	5	5		CYAN COLOR
			0-255	0-WHITE ~ 255-100% CYAN
		6		CYAN COLOR FINE
			0-255	CYAN FINE Adjustment
4	6	7		MAGENTA COLOR
			0-255	0-WHITE ~ 255-100% MAGENTA
		8		MAGENTA COLOR FINE
			0-255	MAGENTA FINE Adjustment
5	7	9		YELLOW COLOR
			0-255	0-WHITE ~ 255-100% YELLOW
		10		YELLOW COLOR FINE
			0-255	YELLOW FINE Adjustment
6	8	11		CTO COLOR
			0-255	0-WHITE ~ 255-100% CTO
		12		CTO COLOR FINE
			0-255	CTO FINE Adjustment
7	9	13		CMY / COLOR MACRO SPEED
			0-255	MAX to MIN Speed
8	10	14		COLOR WHEEL
			0-15	OPEN / WHITE
			16-31	RED
			32-47	BLUE
			48-63	GREEN
			64-79	YELLOW
			80-95	MAGENTA
			96-111	ORANGE
			112-127	LIGHT BLUE
			128-189	*Clockwise COLOR Rotation from FAST to SLOW
			190-193	NO Rotation
194-255	*Counterclockwise COLOR Rotation from SLOW to FAST			
		15		COLOR WHEEL FINE ADJUSTMENT
			0-255	FINE Adjustment of Color Wheel to Any Position

MODE / CHANNEL			VALUE	FUNCTION
BASIC	STAND	EXTEND		
9	11	16		<b>ROTATING GOBOS, CONTINUOUS ROTATION [GOBO WHEEL 1]</b>
			0-9	OPEN
			10-19	Rotating Gobo 1
			20-29	Rotating Gobo 2
			30-39	Rotating Gobo 3
			40-49	Rotating Gobo 4
			50-59	Rotating Gobo 5
			60-69	Rotating Gobo 6
			70-89	Gobo 1 Shake SLOW to FAST
			90-109	Gobo 2 Shake SLOW to FAST
			110-129	Gobo 3 Shake SLOW to FAST
			130-149	Gobo 4 Shake SLOW to FAST
			150-169	Gobo 5 Shake SLOW to FAST
			170-189	Gobo 6 Shake SLOW to FAST
			190-255	*Clockwise Gobo Wheel Rotation from SLOW to FAST
10	12	17		<b>ROTATING GOBOS, INDEX ROTATION [GOBO WHEEL 1]</b>
			0-127	Gobo Indexing
			128-193	*Clockwise Gobo Rotation from FAST TO SLOW
			194-255	*Counterclockwise Gobo Rotation from SLOW to FAST
<b>DMX VALUE CHANGE WITH SOFTWARE UPDATE VERSION <math>\geq</math>1.0.6</b> See highlighted DMX values below which have been updated with this software update.				
10	12	17		<b>ROTATING GOBOS, INDEX ROTATION [GOBO WHEEL 1]</b>
			0-127	Gobo Indexing
			128-189	*Clockwise Gobo Rotation from FAST TO SLOW
			190-193	NO ROTATION
		18	194-255	*Counterclockwise Gobo Rotation from SLOW to FAST
		18		<b>ROTATING GOBOS, FINE INDEX ROTATION [GOBO WHEEL 1]</b>
	0-255		Gobo Rotation FINE Indexing	

MODE / CHANNEL			VALUE	FUNCTION
BASIC	STAND	EXTEND		
11	13	19		STATIC / FIXED GOBOS [GOBO WHEEL 2]
			0-13	OPEN
			14-27	Static / Fixed Gobo 1
			28-41	Static / Fixed Gobo 2
			42-55	Static / Fixed Gobo 3
			56-69	Static / Fixed Gobo 4
			70-83	Static / Fixed Gobo 5
			84-97	Static / Fixed Gobo 6
			98-111	Static / Fixed Gobo 7
			112-127	Shake SLOW to FAST Static / Fixed Gobo 1
			128-143	Shake SLOW to FAST Static / Fixed Gobo 2
			144-159	Shake SLOW to FAST Static / Fixed Gobo 3
			160-175	Shake SLOW to FAST Static / Fixed Gobo 4
			176-191	Shake SLOW to FAST Static / Fixed Gobo 5
			192-207	Shake SLOW to FAST Static / Fixed Gobo 6
			208-223	Shake SLOW to FAST Static / Fixed Gobo 7
224-255	*Clockwise Gobo Wheel Rotation from SLOW to FAST			

**DMX VALUES FOR OPTIONAL STATIC GOBO / ANIMATION WHEEL KIT**

See highlighted DMX values below which support the control of the optional Static GOBO / Animation Wheel Kit.  
Please contact ELATION CUSTOMER SUPPORT for more details.

11	13	19		STATIC / FIXED GOBOS [GOBO WHEEL 2]
			0-13	OPEN
			14-27	Static / Fixed Gobo 1
			28-41	Static / Fixed Gobo 2
			42-55	Static / Fixed Gobo 3
			56-69	Static / Fixed Gobo 4
			70-111	<b>ANIMATION EFFECT</b>
			112-127	Shake SLOW to FAST Static / Fixed Gobo 1
			128-143	Shake SLOW to FAST Static / Fixed Gobo 2
			144-159	Shake SLOW to FAST Static / Fixed Gobo 3
			160-175	Shake SLOW to FAST Static / Fixed Gobo 4
			176-223	<b>ANIMATION EFFECT SHAKE SLOW to FAST</b>
			224-255	*Clockwise Gobo Wheel Rotation from SLOW to FAST

MODE / CHANNEL			VALUE	FUNCTION
BASIC	STAND	EXTEND		
12	14	20		<b>ROTATING PRISM, PRISM / GOBO MACROS</b>
			0-63	OPEN
			64-127	3-FACET Rotating Prism
			128-135	Prism / Gobo Macro 1
			136-143	Prism / Gobo Macro 2
			144-151	Prism / Gobo Macro 3
			152-159	Prism / Gobo Macro 4
			160-167	Prism / Gobo Macro 5
			168-175	Prism / Gobo Macro 6
			176-183	Prism / Gobo Macro 7
			184-191	Prism / Gobo Macro 8
			192-199	Prism / Gobo Macro 9
			200-207	Prism / Gobo Macro 10
			208-215	Prism / Gobo Macro 11
			216-223	Prism / Gobo Macro 12
			224-231	Prism / Gobo Macro 13
			232-239	Prism / Gobo Macro 14
240-247	Prism / Gobo Macro 15			
248-255	Prism / Gobo Macro 16			
13	15	21		<b>ROTATING PRISM, PRISM INDEX ROTATION</b>
			0-127	Prism Indexing
			128-189	*Clockwise Linear Prism Rotation from FAST to SLOW
			190-193	NO Rotation
			194-255	*Counterclockwise Linear Prism Rotation from SLOW to FAST
14	16	22		<b>SHUTTER, STROBE</b>
			0-31	Shutter CLOSED
			32-63	NO Function (Shutter OPEN)
			64-95	Strobe Effect SLOW to FAST
			96-127	NO function (Shutter OPEN)
			128-159	Pulse Effect In Sequences
			160-191	NO Function (Shutter OPEN)
			192-223	Random Strobe Effect SLOW to FAST
224-255	NO Function (Shutter OPEN)			
15	17	23		<b>DIMMER INTENSITY</b>
			0-255	Intensity 0 to 100%
		24		<b>DIMMER INTENSITY FINE [16 BIT]</b>
			0-255	Intensity 0 to 100%
16	18	25		<b>DIMMER CURVE MODES</b>
			0-20	STANDARD
			21-40	STAGE
			41-60	TV
			61-80	ARCHITECTURAL
			81-100	THEATER
		101-255	DEFAULT to UNIT CURVE SETTING	

MODE / CHANNEL			VALUE	FUNCTION
BASIC	STAND	EXTEND		
17	19	26		<b>FROST</b>
			0-127	OPEN
			128-255	100% Frost
18	20	27		<b>IRIS</b>
			0-191	MAX to MIN Diameter
			192-223	Pulse Closing FAST to SLOW
			224-255	Pulse Closing SLOW to FAST
		28		<b>IRIS FINE</b>
			0-255	Iris FINE Adjustment
19	21	29		<b>FOCUS</b>
			0-255	Continuous Adjustment from FAR to NEAR
		30		<b>FOCUS FINE</b>
			0-255	Continuous FINE Focus Adjustment
20	22	31		<b>MOTORIZED ZOOM</b>
			0-255	ZOOM Adjustment from SMALL to BIG
		32		<b>MOTORIZED ZOOM FINE</b>
			0-255	ZOOM FINE Adjustment
21	23	33		<b>BLADE #1</b>
			0-255	OPEN to CLOSE
		34		<b>BLADE #1 FINE [16 BIT]</b>
			0-255	OPEN to CLOSE FINE Adjustment
22	24	35		<b>BLADE #1 ROTATION</b>
			0-255	ROTATION
		36		<b>BLADE #1 ROTATION FINE [16 BIT]</b>
			0-255	ROTATION FINE Adjustment
23	25	37		<b>BLADE #2</b>
			0-255	OPEN to CLOSE
		38		<b>BLADE #2 FINE [16 BIT]</b>
			0-255	OPEN to CLOSE FINE Adjustment
24	26	39		<b>BLADE #2 ROTATION</b>
			0-255	ROTATION
		40		<b>BLADE #2 ROTATION FINE [16 BIT]</b>
			0-255	ROTATION FINE Adjustment
25	27	41		<b>BLADE #3</b>
			0-255	OPEN to CLOSE
		42		<b>BLADE #3 FINE [16 BIT]</b>
			0-255	OPEN to CLOSE FINE Adjustment
26	28	43		<b>BLADE #3 ROTATION</b>
			0-255	ROTATION
		44		<b>BLADE #3 ROTATION FINE [16 BIT]</b>
			0-255	ROTATION FINE Adjustment



MODE / CHANNEL			VALUE	FUNCTION
BASIC	STAND	EXTEND		
27	29	45		<b>BLADE #4</b>
			0-255	OPEN to CLOSE
		46		<b>BLADE #4 FINE [16 BIT]</b>
			0-255	OPEN to CLOSE FINE Adjustment
28	30	47		<b>BLADE #4 ROTATION</b>
			0-255	ROTATION
		48		<b>BLADE #4 ROTATION FINE [16 BIT]</b>
			0-255	ROTATION FINE Adjustment
29	31	49		<b>ALL (4) BLADES ROTATION</b>
			0-255	All (4) Blade Rotation
		50		<b>ALL (4) BLADES ROTATION FINE [16 BIT]</b>
			0-255	All (4) Blade FINE Rotation
30	32	51		<b>BLADE SPEED</b>
			0-255	BLADE Speed FAST to SLOW
31	33	52		<b>BLADE MACROS</b>
			0-14	OFF
			15-29	Blade Macro 1
			30-44	Blade Macro 2
			45-59	Blade Macro 3
			60-74	Blade Macro 4
			75-89	Blade Macro 5
			90-104	Blade Macro 6
			105-119	Blade Macro 7
			120-134	Blade Macro 8
			135-149	Blade Macro 9
			150-164	Blade Macro 10
			165-179	Blade Macro 11
			180-194	Blade Macro 12
			195-209	Blade Macro 13
			210-224	Blade Macro 14
225-239	Blade Macro 15			
240-255	Blade Macro 16			
32	34	53		<b>PAN / TILT MOVEMENT SPEED</b>
			0-225	MAX to MIN Speed
			226-235	Blackout by Movement
			236-255	Blackout by COLOR / GOBO Wheel Movement

MODE / CHANNEL			VALUE	FUNCTION
BASIC	STAND	EXTEND		
33	35	54		LAMP ON/OFF, RESET, INTERNAL PROGRAMS
			0-19	GOBO Change Normal
			20-29	COLOR Change to Any Position
			30-39	GOBO Change to Any Position
			40-59	NO FUNCTION
			60-79	NO FUNCTION
			80-84	ALL Motors Reset
			85-87	SCAN Motor Reset
			88-90	COLOR Motors Reset
			91-93	GOBO Motors Reset
			94-96	NO FUNCTION
			97-99	OTHER Motors Reset
			100-119	Internal Program 1 (Scene1-8)
			120-139	Internal Program 2 (Scene 9-16)
			140-159	Internal Program 3 (Scene 17-24)
			160-179	Internal Program 4 (Scene 25-32)
			180-199	Internal Program 5 (Scene 33-40)
			200-219	Internal Program 6 (Scene 41-48)
			220-239	Internal Program 7 (Scene 49-56)
			240-255	NO FUNCTION

## **E R R O R   C O D E S**

When power is applied, the unit will automatically enter a **“Reset/Test”** mode. This mode brings all the internal motors to a home position. If there is an internal problem with one or more of the motors an error code will flash in the display in the form of **“XXer”** where as XX will represent a function number. For example, when the display shows **“0Er”** it means there is some type of error with the Pan motor. If there are multiple errors during the start-up process they will all flash in the display. For example: if the fixtures has errors on **Channel 1, 2, and 5** all at the same time, you will see the error message **“01Er”, “02Er”, and “05Er”** flash repeated 5 times.

If an error does occur during the initial start-up procedure the fixture will self-generate a second reset signal and try to realign all the motors and correct the errors. If the error persists after a second attempt a third attempt will be made. If after a third attempt all the errors have not been corrected the fixture will make the following determinations:

- **3 or More Errors** - The fixture cannot function properly with three or more errors therefore the fixture will place itself in a stand-by mode until subsequent repairs can be made.
- **Less Than 3 Errors** - The fixture has less than 3 errors; therefore, most other functions will work properly. The fixture will attempt to operate normally until the errors can be correct by a technician. The errors in question will remain flashing in the display as a reminder of internal errors.

## ELATION SATURA PROFILE ERROR CODES

Error Codes are subject to change without any prior written notice.

ERROR CODES	DESCRIPTION
<b>PAN Er</b>	Movement is not located in the default position after the reset. This message will appear after a fixture reset if the magnetic-indexing circuit malfunctions (sensor failed or magnet is missing) or there is a motor failure (defective motor or a defective motor IC drive on the main PCB). This error may also be displayed if the head/yoke was blocked during a reset function.
<b>TILT Er</b>	
<b>Cyan Color Wheel Er</b>	Movement is not located in the default position after the reset. This message will appear after a fixture reset if the magnetic-indexing circuit malfunctions (sensor failed or magnet is missing) or there is a motor failure (defective motor or a defective motor IC drive on the main PCB).
<b>Magenta Color Wheel Er</b>	
<b>Yellow Color Wheel Er</b>	
<b>CTO Color Wheel Er</b>	
<b>Speed of CMY Wheel Er</b>	
<b>Color Wheel Er</b>	
<b>Gobo Wheel 1 Er</b>	
<b>Gobo Rot. 1 Wheel Er</b>	
<b>Fixed Gobo Wheel Er</b>	
<b>Rotating Prim Er</b>	
<b>Iris Er</b>	
<b>Focus Er</b>	
<b>Zoom Er</b>	
<b>Blade 1 Er</b>	
<b>Blade 2 Er</b>	
<b>Blade 3 Er</b>	
<b>Blade 4 Er</b>	
<b>g4UFan1 Error</b>	Error information from JB1 port on 4U01 PCB. Displayed as 4U_Fan1 RPM <1000.
<b>g4UFan2 Error</b>	Error information from JB2 port on 4U01 PCB. Displayed as 4U_Fan2 RPM <1000.
<b>g5UFan1 Error</b>	Error information from JB2 port on 5U01 PCB. Displayed as 5U_Fan1 RPM <1000.
<b>g5UFan2 Error</b>	Error information from JB2 port on 5U01 PCB. Displayed as 5U_Fan2 RPM <1000.
<b>Temp Error</b>	Temperature <37.4°F (3°C) or >320°F (160°C).

# SPECIFICATIONS

## SOURCE

440W Cool White 15,000 Lumen LED Engine

50,000 Hour Average LED Life\*

\*May vary depending on several factors including but not limited to:  
Environmental Conditions, Power/Voltage, Usage Patterns (On-Off Cycling), Control, and Dimming.

## EFFECTS

Motorized Zoom

4-Blade Framing Shutter System

3-Facet Rotating Prism and Prism Macros

Frost Filter Hybrid Wash Effect

Motorized Zoom, Iris and Focus

High Speed Electronic Shutter and Strobe

Variable Dimming Curve

## COLOR

7 Dichroic Colors

Full CMY Color Mixing

Linear CTO Color Correction

## GOBOS

(2) Gobo Wheels

(6) Interchangeable-Rotating / Indexing Glass Gobos

(7) Interchangeable Static-Stamped Metal Gobos

(4) Interchangeable Static-Stamped Metal Gobo/Animation Wheel Kit\*

\*Optional Kit Sold Separately

## CONTROL / CONNECTIONS

(3) DMX Channel Modes (33 / 35 / 54)

RDM (Remote Device Management)

6 Button Touch Control Panel

Full Color 180° Reversible LCD Menu Display

8 / 16 Bit Resolution Adjustable Movement

3pin and 5pin DMX In/Out

RJ45 Ethernet In/Out (Art-NET)

Locking Power Cable In

## SIZE / WEIGHT

Length: 17.7" (450mm)

Width: 20.7" (525mm)

Vertical Height: 29.3" (745mm)

Weight: 75.0 lbs. (34.0 kg)

## ELECTRICAL / THERMAL

AC 100-240V - 50/60Hz

600W Max Power Consumption

14°F to 113°F (-10°C to 45°C)

## APPROVALS / RATINGS

CE| IP20



Specifications and improvements in the design of this unit and this manual are subject to change without any prior written notice.

## COLORS AND GOBOS

### COLOR FLAGS



### COLOR WHEEL



### INTERCHANGEABLE-ROTATING GOBO WHEEL 1 - OD: Ø28.8mm\*\* ID: Ø24.0mm

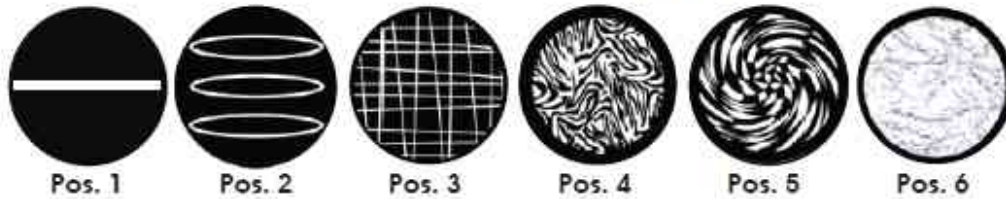

### INTERCHANGEABLE STATIC-FIXED GOBO WHEEL 2 - OD: Ø27.0mm\*\* ID: Ø22.0mm

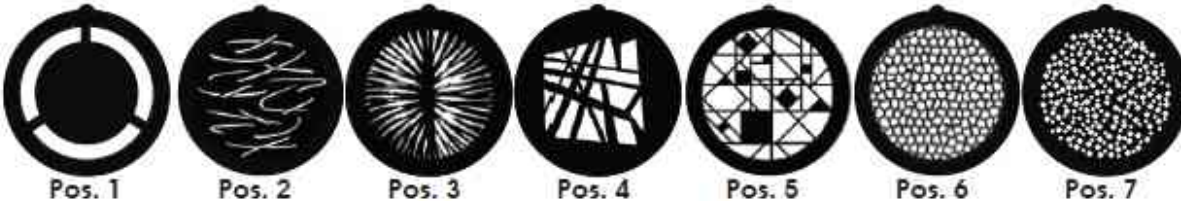

## \*\*IMPORTANT NOTICE REGARDING GOBO DIMENSIONS AND CUSTOM GOBOS

**OD = Outside Diameter | ID = Image Diameter**

**Due to varying manufacturing processes, it is highly recommended to provide a gobo and holder sample from the fixture to 3rd party custom gobo vendors for accurate sizing.**

Specifications and improvements in the design of this unit and this manual are subject to change without any prior written notice.

### FCC STATEMENT

This device complies with Part 15 of the FCC Rules. Operation is subject to the following two conditions: (1) this device may not cause harmful interference, and (2) this device must accept any interference received, including interference that may cause undesired operation.

### FCC RADIO FREQUENCY INTERFERENCE WARNINGS & INSTRUCTIONS

This product has been tested and found to comply with the limits as per Part 15 of the FCC Rules. These limits are designed to provide reasonable protection against harmful interference in a residential installation. This device uses and can radiate radio frequency energy and, if not installed and used in accordance with the included instructions, may cause harmful interference to radio communications.

However, there is no guarantee that interference will not occur in a particular installation. If this device does cause harmful interference to radio or television reception, which can be determined by turning the device off and on, the user is encouraged to try to correct the interference by one or more of the following methods:

- Reorient or relocate the device.
- Increase the separation between the device and the receiver.
- Connect the device to an electrical outlet on a circuit different from which the radio receiver is connected.
- Consult the dealer or an experienced radio/TV technician for help.

## DIMENSIONAL DRAWINGS

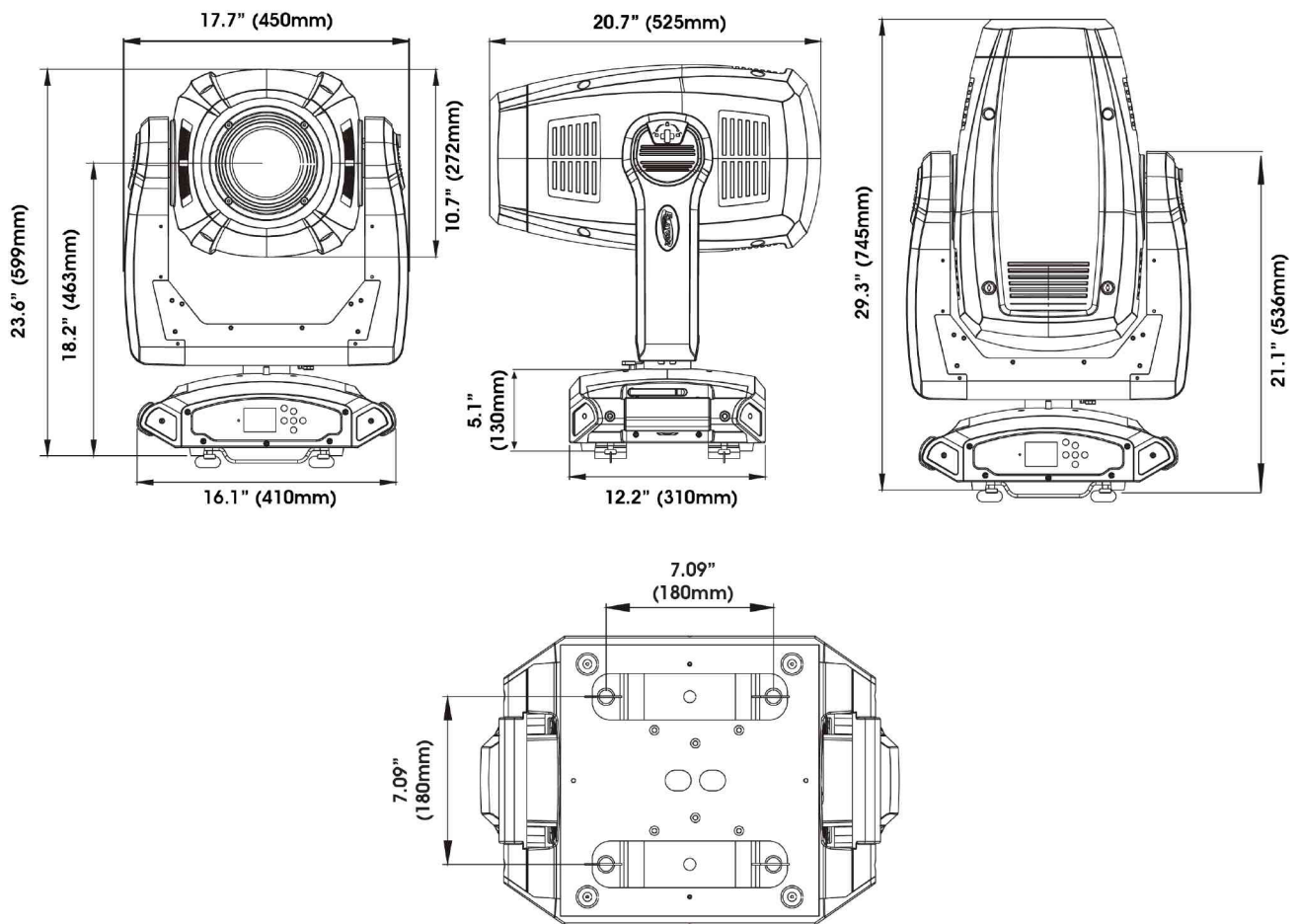

Please Note: Specifications and improvements in the design of this unit and this manual are subject to change without any prior written notice.

## OPTIONAL ACCESSORIES

ORDER CODE	ITEM
TRIGGER CLAMP	Heavy Duty Wrap Around Hook Style Clamp
DRCSATPRO	Dual Touring Road Case for SATURA PROFILE
501020103010	Optional Static Gobo / Animation Wheel Kit
AC3PDMX5PRO	5 ft. (1.5m) 3pin PRO DMX Cable
AC5PDMX5PRO	5 ft. (1.5m) 5pin PRO DMX Cable
CAT6PRO5	5 ft. (1.5m) CAT6 Ethernet Cable
	Additional Cable Lengths Available

