

E Spot Led™

Elation Professional
6122 S Eastern Ave
Los Angeles, Ca 90040
www.elationlighting.com

CONTENTS

1. General Information.....	4
a. Introduction.....	4
b. Unpacking.....	4
c. Customer Support.....	4
d. Warranty Registration.....	5
2. Safety Instructions.....	6
3. Features.....	7
4. General Guidelines.....	8
5. Fixture Overview.....	9
6. Mounting and Installation.....	12
a. Mounting Positions.....	12
b. Mounting Points.....	13
c. Securing.....	14
7. Understanding DMX.....	15
a. DMX Cable Requirements.....	15
b. DMX Terminator.....	17
c. 3-Pin to 5-Pin Conversion.....	17
8. Fixture Menu.....	19
a. Menu functions.....	21
9. DMX Addressing.....	29
10. DMX Channel Traits.....	38
a. DMX Channel Values.....	39
11. Error Codes.....	41
12. Cleaning and Maintenance.....	42
13. Photometric Data.....	43
14. Gobos	
15. Dimensional Drawings.....	45
16. Circuit Schematic.....	46
17. Technical Specifications.....	49

1. GENERAL INFORMATION

INTRODUCTION: Congratulations, you have just purchased one of the most innovative and reliable lighting fixtures on the market today! The E Spot Led,™ has been designed to perform reliably for years when the guidelines in this booklet are followed. Please read and understand the instructions in this manual carefully and thoroughly before attempting to operate this unit. These instructions contain important information regarding safety during use and maintenance.

UNPACKING: Thank you for purchasing the E Spot Led™ by Elation Professional®. Every E Spot Led™ has been thoroughly tested and has been shipped in perfect operating condition. Carefully check the shipping carton for damage that may have occurred during shipping. If the carton appears to be damaged, carefully inspect your unit for damage and be sure all accessories necessary to operate the unit have arrived intact. In the event damage has been found or parts are missing, please contact our customer support team for further assistance. Please do not return this unit to your dealer without first contacting customer support at the number listed below.

Inside the box you should find: the E Spot, a DMX cable, a safety cable, two omega clamps and this manual. Please contact customer support at the number listed below if any items are missing.

During initial fixture start-up, the fixture may omit some light smoke or release a slight burning smell. This is a normal process and should decrease gradually.

CUSTOMER SUPPORT: Elation Professional® provides a customer support line, to provide set up help and to answer any question should you encounter problems during your set up or initial operation. You may also visit us on the web at www.elationlighting.com for any comments or suggestions. For service related issue please contact Elation Professional®. Service Hours are Monday through Friday 8:00 a.m. to 5:00 p.m. Pacific Standard Time.

Voice: (323) 582-3322

Fax: (323) 832-9142

E-mail: support@elationlighting.com

Forum: www.ElationLighting.com/forum

Warning! To prevent or reduce the risk of electrical shock or fire, do not expose this unit to

rain or moisture.

Caution! There are no user serviceable parts inside this unit. Do not attempt any repairs yourself, doing so will void your manufactures warranty.

Please do not discard the shipping carton in the trash. Please save for return shipping in the event service is ever needed or recycle the container whenever possible.

WARRANTY REGISTRATION: The E Spot Led™ carries a two year (730 days) limited warranty. Please fill out the enclosed warranty card to validate your purchase. All returned service items whether under warranty or not, must be freight pre-paid and accompany a return authorization (R.A.) number. The R.A. number must be clearly written on the outside of the return package. A brief description of the problem as well as the R.A. number must also be written down on a piece of paper and included in the shipping container. If the unit is under warranty, you must provide a copy of your proof of purchase invoice. Items returned without a R.A. number clearly marked on the outside of the package will be refused and returned at customer's expense. You may obtain a R.A. number by contacting customer support at (323) 582-3322.

Epileptic Warning: *Those suffering from epilepsy should avoid looking directly into the light source at all times.*

Never open this fixture while in use!

This device falls under protection-class 1. Therefore it is essential that the device be grounded properly.

All electrical connections must be performed by qualified personal.

Be sure the available voltage matches the voltage requirements of the unit.

Be sure the power cord is never crimped or damaged. If the power cord is damaged, replace it immediately with a new one of similar power rating.

Only handle the power cord by the plug. Never pull out the plug by tugging the wire portion of the cord.

2. SAFETY INSTRUCTIONS



The E Spot Led™ is an extremely sophisticated piece of electronic equipment. To guarantee a trouble free operation, it is important to follow the guidelines in this manual. Elation will not accept responsibility for damages resulting from the misuse of this fixture due to the disregard of the information printed in this manual.

1. Always be sure that the fan and the air inlets remain clean and are never blocked. Allow about 6" (15cm) between this fixture and other devices or a wall to allow for proper cooling.
2. Never touch the fixture during normal operation. This can cause severe personnel injuries and/or damage to the fixture.
3. Be sure to unplug the E Spot Led™ from the power outlet before performing any service or cleaning related issues.
4. Never look directly into the light source. You risk injury to your retina, which may induce blindness.
5. For safe operation, follow the Installation guide described in chapter two of this manual. Operating the E Spot Led™ without suited safety aids such as safety cables or clamps can increase the risk of damage and/or personal injury.
6. When mounting this fixture, use only the original rigging parts included with this fixture. Any structural modification will void the original manufactures warranty and may increase the risk of damage and/or personal injury.
7. To reduce the risk of fire or shock, do not expose this fixture to rain or moisture.
8. Do not attempt to operate this fixture if the power cord has become damaged or frayed.
9. Installation should only be performed by qualified and certified personal.

Important Notice: Damages resulting from the disregard of safety and general user instructions found in this user manual are not subject to any warranty claims.

3. FEATURES

- Pan 540° or 630° (User selectable) / Tilt 270°
- 15° Beam Angle
- Low Power Consumption
- 60 WATT White LED Source (Over 2,200 lumens from a single chip)
- 60,000 hours ***rated*** LED life
- Color Wheel: 8 colors plus white, with rainbow effect
- Rotating gobo wheel with 7 rotating gobos plus open, all gobos can be easily replaceable and gobo indexing
- Prism and Prism Rotation, with 16 prism macros (Indexable)
- Flicker-free operation for television and film
- 3 operation mode: DMX controlled, stand alone or sound activated
- Strobe effect: 0~18 flashes per second or random strobe
- 0%~100% Dimming (two dimming options; linear & standard)
- Electronic menu display
- Control board with full LCD character display and foil-keyboard
- RDMX (Remote DMX addressing from any DMX console)
- Auto test for all functions
- Automatic Pan/Tilt Correction
- USITT DMX-512 Complaint (3-pin and 5-pin DMX Connections)
- Value of each DMX-channel can be displayed
- Minimal heat emission
- Maintenance free operation
- Preprogrammed colored macros
- Electronic power supply (100v~240V 50/60Hz)
- 8 built-in programs accessed via DMX-controller or manually
- Built-in DMX recorder - via the control board or external controller, up to 64 scenes can be saved and then can be run in Stand Alone or sound activated.

4. GENERAL GUIDELINES

This fixture is a professional lighting effect designed for use on stage, in nightclubs, in theatres, etc. Do not attempt operation or installation without a proper knowledge on how to do so.

This fixture was designed for indoor use only.

Consistent operational breaks may ensure that the fixture will function properly for many years to come.

Do not shake the fixture around. Avoid brute force when installing or operating the device.

While choosing an installation location, please be sure that the fixture will not be exposed to extreme heat, moisture or dust. The minimum distance between the fixture and a wall or flat surface should be at least 0.5 meter (about 1.5ft).

Always install the fixture with an appropriate safety cable. When installing the fixture in a suspended environment always be sure to use mounting hardware no less than M10 x 25 mm, also be sure the hardware is insert in the pre-arranged screw holes in the base of the fixture.

When using the quick release “Omega” cam-lock system, be sure the four quick lock fasteners are locked in the quick lock holes correctly.

Do not attempt to operate this fixture until you have familiarized yourself with its functions.

Do not permit operation by persons not qualified for operating this type of theatrical fixture; most damages are the result of operations by nonprofessionals.

Please use the original packaging to transport the fixture in for service.

5. FIXTURE OVERVIEW

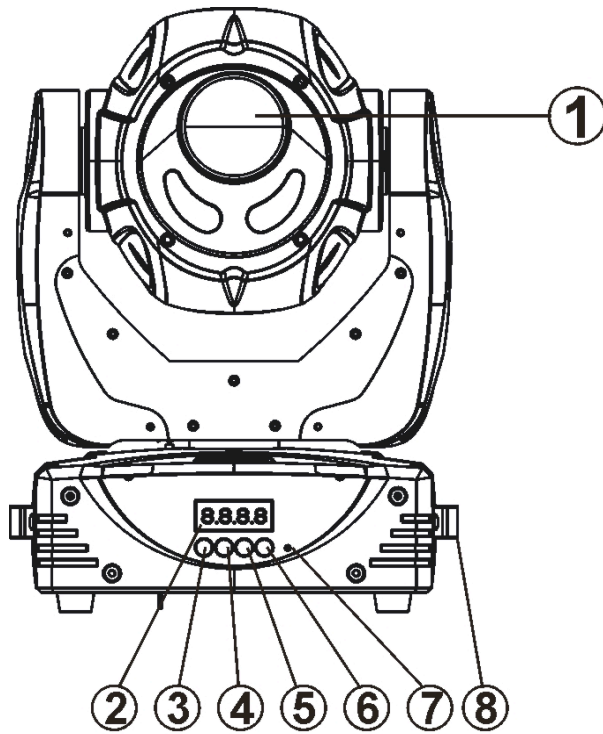

1. LED Assembly
2. LCD Menu Display
3. Mode/Esc Button
4. Up Button
5. Down Button
6. Enter Button
7. Microphone
8. Carrying Handle
9. 3-Pin DMX Output
10. 3-Pin DMX Input
11. 5-Pin DMX Output
12. 5-Pin DMX Input
13. Power Switch
15. Fuse Holder
16. Power Cord

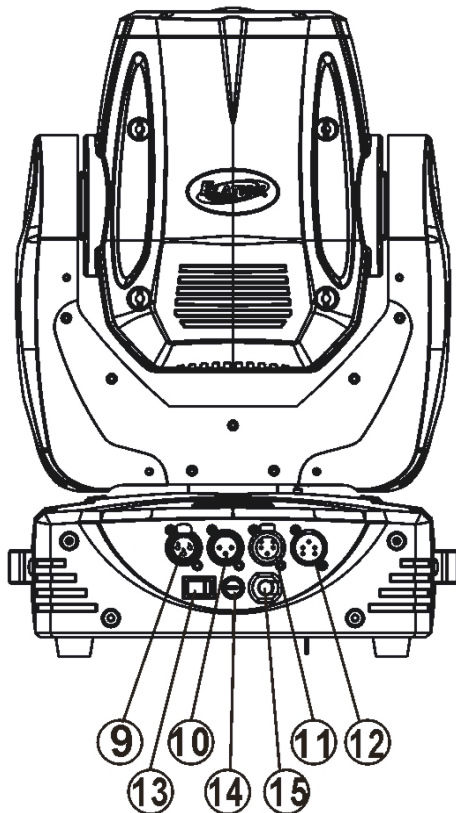

1. **LED**—Extremely high optical LED output, Over 2,200 lumens from a sin-gle chip (White)
2. **LED Menu Display** - 4-segment menu display. Used to display the DMX address as well as all other menu functions.
3. **Mode/Esc Button** - This button is used to access the menu functions.
4. **Up Button** – The up button is used to toggle forward through the menu functions and settings.
5. **Down Button** – The down button is used to toggle backwards through the menu functions and settings.
6. **Enter Button** – The enter button is used to enter in to a certain menu function or to lock a function into memory.
7. **Microphone** – Internal microphone is used to trigger built-in scenes to sound.
8. **Carrying Handle** – Please use this intergraded handled to move the fixture form location to location. Never carry the fixture by the head.
9. **3-Pin DMX Output Jack** – This jack is used to send an incoming DMX signal to the next fixture in the DMX chain via a female, 3-pin XLR jack.
10. **3-PIN DMX Input Jack** – This jack accepts an incoming DMX signal via a male, 3-pin XLR jack.
11. **5-Pin DMX Output Jack** – This jack is used to send an incoming DMX signal to the next fixture in the DMX chain via a female, 3-pin XLR jack.
12. **5-PIN DMX Input Jack** – This jack accepts an incoming DMX signal via a male, 5-pin XLR jack.

13. Power Switch – Controls main power to the unit.

14. Fuse Holder Assembly – This assembly houses the 4amp GMA safety fuse. Always replace the fuse with an exact match unless otherwise specified by an authorized Elation Service Technician. Using a fuse other than that specified could seriously damage the unit and will void your manufactures warranty.

15. Power Cord – Plug into an appropriate power outlet to provide main power to the fixture.

6. MOUNTING AND INSTALLATION

Cautions:

For added protection mount the fixtures in areas outside walking paths, seating areas, or in areas where the fixture might be reached by unauthorized personnel.

Before mounting the fixture to any surface, make sure that the installation area can hold a minimum point load of 10 times the device's weight.

Fixture installation must always be secured with a secondary safety attachment, such as an appropriate safety cable.

Never stand directly below the device when mounting, removing, or servicing the fixture.



Caution!

When install the fixture be sure there is no highly inflammable material within a distance of .5m (1.5 feet)

Mounting

The E Spot Led™ is fully operational in two different mounting positions, hanging upside-down from a ceiling, or set on a flat level surface (see illustration on the next page). Never mount the fixture on its' side in any type of installation. Be sure this fixture is kept at least 0.5m (1.5 feet) away from any flammable materials (decoration etc.). Always use and install the supplied safety cable as a safety measure to prevent accidental damage and/or injury in the event the clamp fails.



Refer to regulations BGV C1 (formerly VBG 70) and DIN VDE0711-217 for proper installation in Europe To ensure proper installation, only qualified staff should attempt installation.

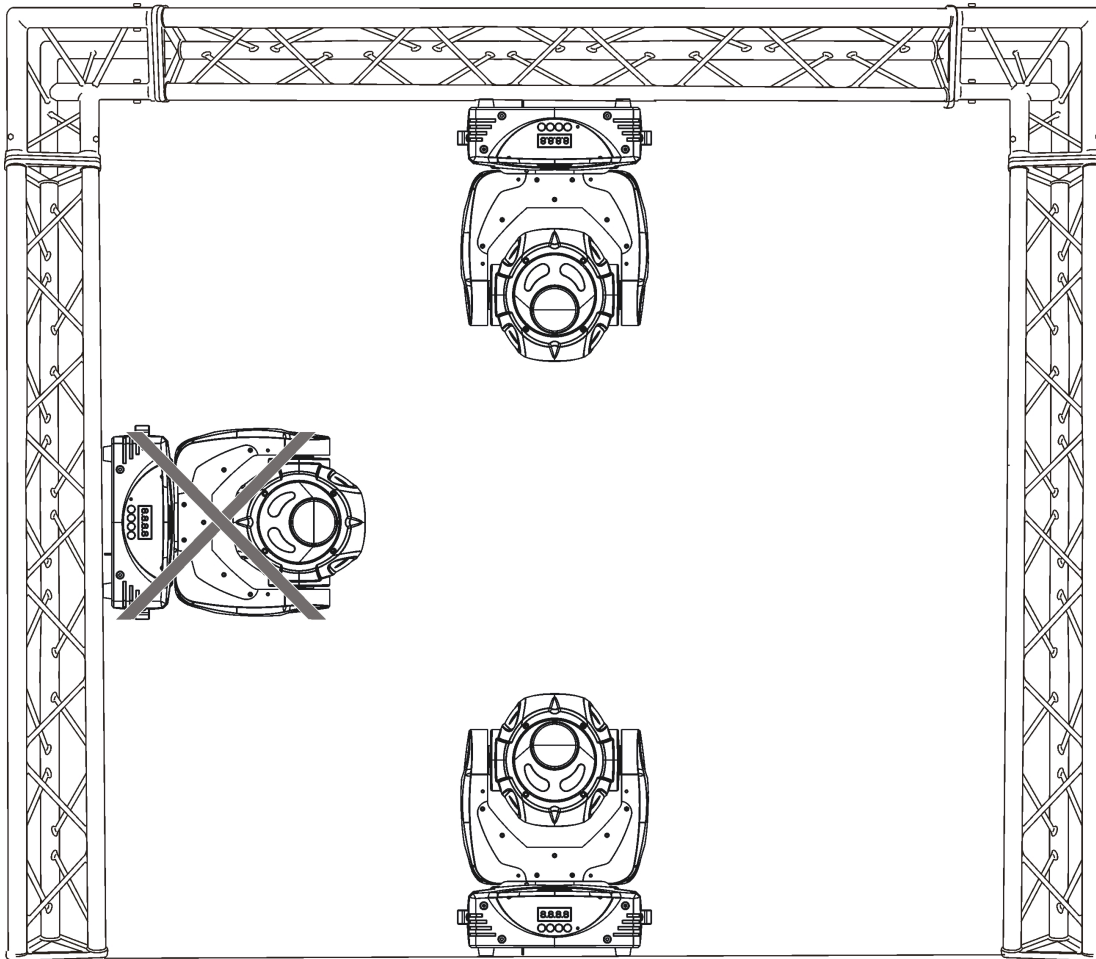

Mounting points

Overhead mounting requires extensive experience, including amongst others calculating working load limits, a fine knowledge of the installation material being used, and periodic safety inspection of all installation material and the fixture. If you lack these qualifications, do not attempt the installation yourself. Improper installation can result in bodily injury.

	<p>CAUTION! Be sure a qualified electrician performs all electrical connections.</p>
---	---

Be sure to complete all rigging and installation procedures before connecting the main power cord to the appropriate wall outlet. **Clamp Mounting**

The E Spot Led™ provides a unique mounting bracket assembly that integrates the bottom of the base, the included “Omega Bracket,” and the safety cable rigging point in one unit (see the illustration below). When mounting this fixture to truss be sure to secure an appropriately rated clamp to the included omega bracket using a M10 screw fitted through the center hole of the “omega bracket”. As an added safety measure be sure to attached at least one properly rated safety cable to the fixture using the safety cable rigging point integrated in the base assembly

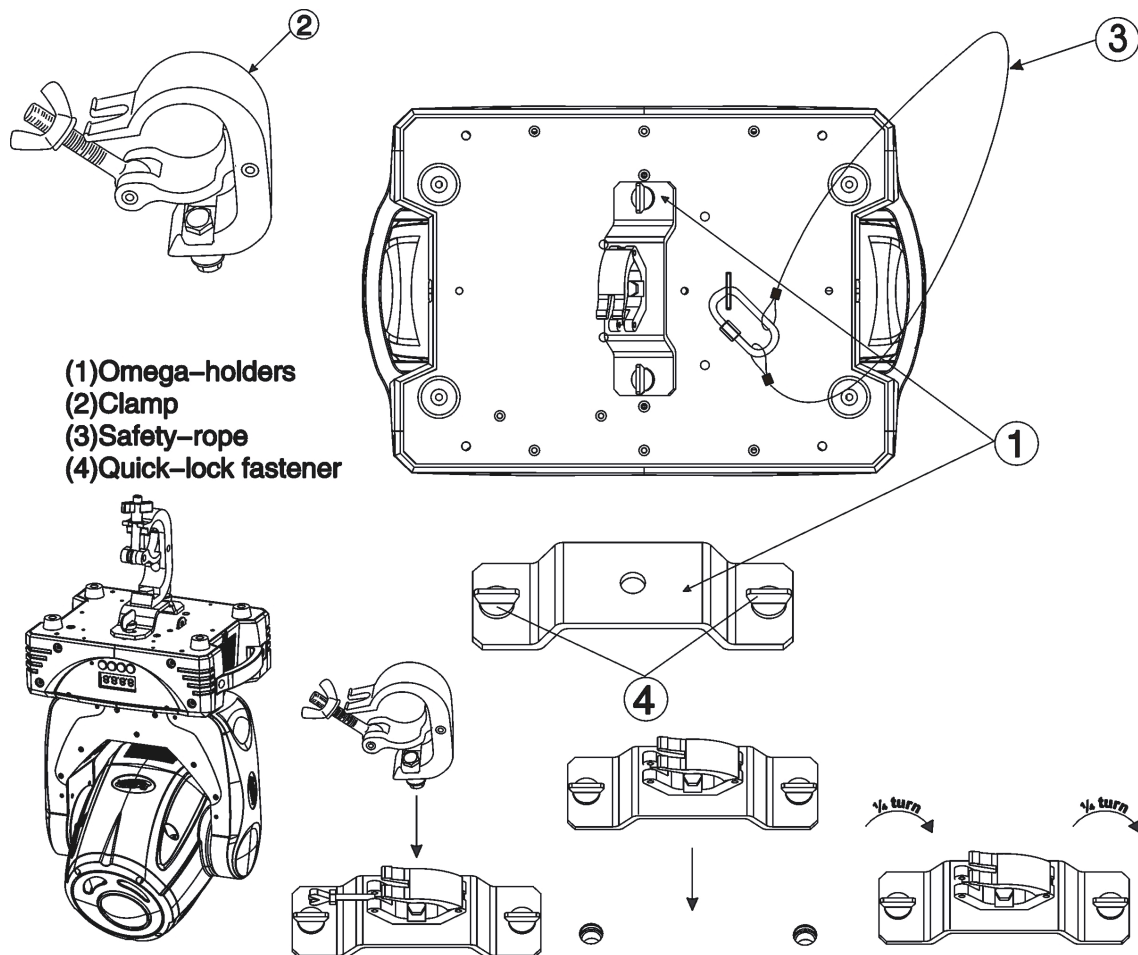

Securing the E Spot Led™

Regardless of the rigging option you choose for your E Spot Led™ always be sure to secure your fixture with a safety cable. The fixture provides a built-in rigging point for a safety cable on the hanging bracket as illustrated above. Be sure to only use the designated rigging point for the safety cable and never secure a safety cable to a carrying handle.

7. UNDERSTANDING DMX

DMX-512: DMX is short for Digital Multiplex. This is a universal protocol used by most lighting and controller manufactures as a form of communication between intelligent fixtures and controllers. DMX allows all makes and models of different manufactures to be linked together and operate from a single controller. This is possible as long as all the fixtures and the controller are DMX compliant. A DMX controller sends the DMX data instructions to the fixture allowing the user to control the different aspects of an intelligent light. DMX data is sent out as serial data that travels from fixture to fixture via data “IN” and data “OUT” XLR terminals located on the fixtures (most controllers will only have output jacks).

DMX Linking: To ensure proper DMX data transmission, always use proper DMX cables and a terminator. When using several DMX fixtures try to use the shortest cable path possible. Never split a DMX line with a “Y” style connector. The order in which the fixtures are connected in a DMX line does not influence the DMX addressing. For example; a fixture assigned a DMX address of 1 may be placed anywhere in the DMX chain, at the beginning, at the end, or anywhere in the middle. The DMX controller knows to send data assigned to address 1 to that fixture no matter where it is located in the DMX chain. The E Spot Led™ can be controlled via DMX-512 protocol. The E Spot Led™ is a 14-channel DMX fixture. The DMX address is set electronically using the controls on the LCD menu.



Note: Although microphone and DMX cables may look similar, they are not constructed of the same material and should never be used in place of each other.

Data Cable (DMX Cable) Requirements (For DMX and Master/Slave Operation): Your fixture and your DMX controller require a standard 3-pin or 5-pin XLR connector for data input and data output (the figure on the next page is of a 3-Pin XLR connector). If you are making your own cables, be sure to use two conductor shielded digital DMX cable rated at 120 ohms; this cable is designed for DMX transmission and may be purchased from your Elation dealer or at most professional lighting retailers. Your cables should be made with a male and female XLR connector on either end of the cable. Also, remember that a DMX line must be daisy chained and cannot be split, unless using an approved DMX splitter such as

the Elation Opto Branch 4™ or DMX Branch/4™.

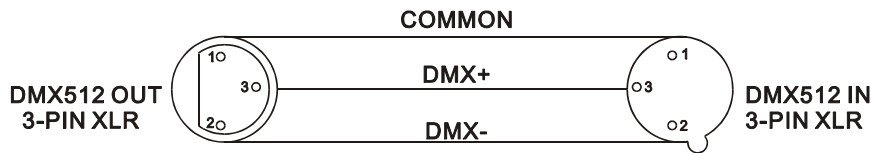

Be sure to follow the above figure when making your own cables. Do not use the ground lug on the XLR connector. Do not connect the cable's shield conductor to the ground lug or allow the shield conductor to come in contact with the XLR's outer casing. Grounding the shield could cause a short circuit and erratic behavior.



DMX-512 control connection

Connect the provided XLR cable to the female 3-pin XLR output of your controller and the other side to the male 3-pin XLR input of the moving head (Please refer to the diagram below.). You can chain multiple moving heads together through serial linking. The cable that should be used is two conductor, shielded DMX cable with XLR input and output connectors. Always be sure daisy chain your in and out data connections, never split or “Y” your DMX connections unless you are using an approved DMX splitter such as the Elation Opto Branch 4™ or DMX Branch/4™.

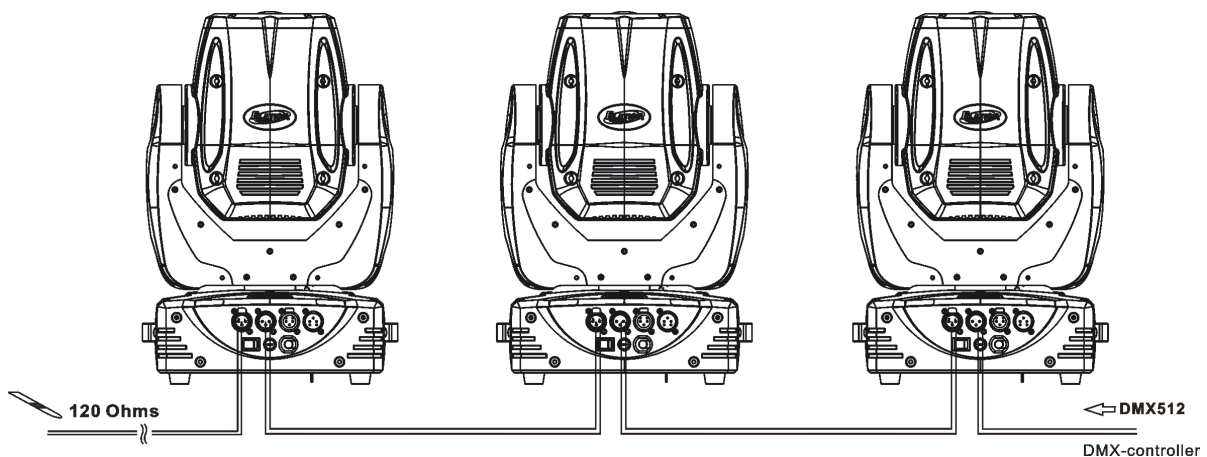

DMX-512 connection with DMX terminator

A DMX terminator should be used in all DMX lines especially in longer runs. The use of a terminator may avoid erratic behavior in your DMX line. A terminator is a 120 ohm 1/4 watt resistor that is connected between pins 2 and 3 of a male XLR connector (DATA + and DATA -). This fixture is inserted in the female XLR connector of the last fixture in your daisy chain to terminate the line. Using a *line terminator (Elation part: DMX T PACK)* will decrease the possibilities of erratic behavior.

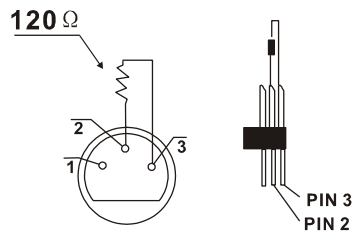

Termination reduces signal errors and avoids signal transmission problems and interference. It is always advisable to connect a DMX terminal, (Resistance 120 Ohm 1/4W) between PIN 2 (DMX-) and PIN 3 (DMX+) of the last fixture.

5-Pin XLR DMX Connectors. Some manufactures use 5-pin XLR connectors for DATA transmission in place of 3-pin. 5-pin XLR fixtures may be implemented in a 3-pin XLR DMX line. When inserting standard 5-pin XLR connectors in to a 3-pin line a cable adaptor must be used, these adaptors are readily available at most electric stores. The following chart details a proper cable conversion.

3-Pin XLR to 5-Pin Conversion		
Conductor	3-Pin XLR Female(Out)	5-Pin XLR Male(In)
Ground/ Shield	Pin 1	Pin 1
Data Compliment(-signal)	Pin 2	Pin 2
Data True(+signal)	Pin 3	Pin 3
Not Used		Pin 4 - Do Not Use
Not Used		Pin 5 - Do Not Use

Fixture DMX addressing;

All fixtures should be given a DMX starting address when using a DMX controller, so the correct fixture responds to the correct control signal. This digital starting address is the channel number from which the fixture starts to “listen” to the digital control information sent

out from the DMX controller. The allocation of this starting DMX address is achieved by setting the correct DMX address on the digital display located on the base of the fixture.

You can set the same starting address for all fixtures or a group of fixtures, or set different address for each individual fixture. Be advised that setting all you fixtures to the same DMX address will subsequently control all fixtures in the same fashion, in other words, changing the settings of one channel will affect all the fixtures simultaneously.

If you set each fixture to a different DMX address, each unit will start to “listen” to the channel number you have set, based on the quantity of control channels (DMX channels) of each fixture. That means changing the settings of one channel will only affect the selected fixture.

In the case of the E Spot Led™, which is a 14 channel fixture, you should set the starting DMX address of the first unit to 1, the second unit to 15 (14 + 1), the third unit to 29 (14 + 15), and so on.

Note: During start-up the E Spot Led™ will automatically detect whether a DMX data signal is being received or not. If DMX data signal is being received, the display will show "**Addr=XXX**" (XXX representing the actual DMX address). If the fixture is not receiving a DMX signal the display will flash. If your fixture is connected to a DMX controller and the display is flashing (not receiving a DMX signal), please check the following:

- The 3-PIN or 5-PIN XLR input plug (cable with DMX signal from controller) is not connected or is not inserted completely into the DMX input jack of the fixture.
- The DMX controller is switched off or defective.
- The DMX cable or connector is defective.
- A DMX terminator has been inserted into the last fixture in your DMX chain.

8. FIXTURE MENU

On-Board System Menu: The E Spot Led™ comes with an easy to navigate system menu. This next section will detail the functions of each command in the system menu.

LCD Control Panel: The control panel located on the base of the fixture allows you to access the main menu and make all necessary adjustments to the E Spot Led™. During normal operation, tapping the “**Mode/Esc**” key once will access the fixture’s main menu. Once in the main menu you can navigate through the different functions and access the sub-menus with the **Up** and **Down** buttons. Once you reach a field that requires adjusting, tap the **ENTER** button to activate that field and use the **UP** and **Down** button to adjust the field. Tapping the **Enter** button once more will confirm your setting. Once a setting is saved the display will briefly readout *OK* to confirm a new setting has been made and locked into memory. You may exit the main menu at any time without making any adjustments by tapping the **Mode/Esc** button.

MODE/ESC Button - To access the main menu locate the **Mode/Esc** button on the front of the unit. Press this button to activate the system menu. Tap the **UP** button until you reach the function you wish to change. When you reach the function you wish to change tap the **ENTER** button once to select that menu function. When a function is selected use either the **UP** or **DOWN** buttons to change the function. Once your changes are made tap the **ENTER** button yet again to lock the change in the system menu. To exit without making any changes tap the **Mode/Esc** button.

Default settings shaded.

0	ADDR	AXXX A001		Indicate the starting DMX address A001 also is the setting for slave
1	TEST	T-01~T-XX		Automatically test the function
2	PLAY	RUN	MSTR/ALON	Runs fixture as “master” or “alone” for auto
		AUDI	MSTR/ALON	Runs fixture as “master” or “alone” for audio
		AUTO	Clos/ Hold /Auto/Audi	No DMX Status
3	RESE	ALL		Reset all motors and returns fixture to home
		SCAN		Reset only motors for pan/tilt
		COLR		Reset only motors for colors

		GOBO		Reset only motors for gobo and rotation	
		OTHR		Reset other motors	
4	TIME	LIFE	0000~9999	Displays the total fixture running time	
		CLMP		Clear lamp running time	
5	RPAN	ON/OFF		Reverses the pan movements	
6	RTLTL	ON/OFF		Reverses the tilt movements	
7	FINE	ON/OFF		Switch 16 bit/8 bit	
8	DEGR	540/630		Pan degree select	
9	MIC	M-XX M-70		Mic sensitivity	
10	DISP	VALU	D-XX D-00 (DXXX)	Display the DMX512 value of each channel	
		D ON	ON/OFF	Display turn off after 2mins	
		FLIP	ON/OFF	This function will reverse the display 180	
11	SPEC	RDMX	ON/OFF	Change DMX address via external controller	
		SPOT	ON/OFF	Lamp optimization	
		DFSE	ON/OFF	Resets all the fixture functions to default	
		FEED	ON/OFF	Pan/tilt feedback (error correction) on/off	
		FANS	AUTO/HIGH/LOW	Fan's mode select	
		VER	V1.0~V9.9	Software version	
		ADJU	CODE CH01~CHXX	CXXX XXXX(-128~127)	Srvice code is "C050" Motor Fix
12	EDIT	SEPR	AUTO IP01~IP08	Select program to be edit	
		STEP	S-01 ~S-48	Set the amount of your program	
		SCXX	C-01~C-XX	0 1 XX(00~FFH) XX XX(00~FFH)	Edit the channels of each scene
			TIME	T XXX(001~999)	Time for each scene
			CEDT	ON/OFF	Edit program via controller
		REC.	RE.XX		Auto Save
		RUN	ON/OFF		Program test

Main Menu Functions

1. ADDRESS MENU

Addr - A001 - A511 (Value) - This is where you set the fixtures DMX address.

Setting/Changing the DMX Address

After applying power to the E Spot Led™ the LED will display the fixture's current DMX address immediately after the reset sequence. If the fixture is not receiving a DMX signal the display will flash continuously. To set or adjust a DMX address, please follow the procedure below:

1. Switch on the E Spot Led™ and wait for the fixture reset process to finished.
2. Press the Mode/Esc button to access the main menu. Toggle through the menu by pressing the Up and Down buttons until the display shows A001. Tap the enter button to make changes to the address, the current three digit address will immediately begin to flash.
3. While the current three-digit address is flashing, use the Up and Down buttons to select adjust the address. Lock your new address into the unit's memory by pressing the Enter button. After the new address has been successfully stored into the fixture's memory the LED will briefly readout PASS.

The DMX address is non-destructible and will remain in the fixture's memory even when power to the fixture has been switched off. Memory is backed-up and retained by an internal power source with a five year shelf life.

2. TEST MENU



T-01 - T-XX (Test) - Tests the functions of channel. To enter the test menu follow the procedure below:

1. Access the main menu.
2. Tap the UP button until "TEST" is displayed, press ENTER.
3. The display will read T-01. You can now press the up button and test the different channels. For example: If you press the up button until "T-05" is displayed, the unit will test the color channel, changing the color one by one and show the rainbow effect with different speeds.
4. Press MODE/ENTER or EXIT to exit.

3. PLAY MENU -

RUN



– This feature is used to run the internal preset programs in either a Master/Slave or a stand-alone operating mode. Follow the procedure below to enter the run menu:

1. Access the main menu.
2. Tap the UP or DOWN button until "PLAY" is displayed, press ENTER.
3. Tap the UP or DOWN button until "RUN" is displayed, press ENTER.

4. Tap the UP or DOWN button to select either “Master” or “Alone” and press ENTER.
5. Press MODE/ESC to return to the main menu.

AUDI

AUDI - This feature is used to run the internal preset programs in AUDIO mode in either a Master/Slave or a stand-alone operating mode. Follow the procedure below to enter the audio menu:

1. Access the main menu.
2. Tap the UP or DOWN button until “PLAY” is displayed, press ENTER.
3. Tap the UP or DOWN button until “AUDI” is displayed, press ENTER.
4. Tap the UP or DOWN button to select either “Master” or “Alone” and press ENTER.
5. Press MODE/ESC to return to the main menu.

AUTO

AUTO – Runs the unit without any DMX signal in stand-alone mode. Follow the procedure below to enter the auto menu:

1. Access the main menu.
2. Tap the UP or DOWN button until “PLAY” is displayed, press ENTER.
3. Tap the UP or DOWN button until “AUTO” is displayed, press ENTER.
4. Tap the UP or DOWN button to select “CLOS”, “HOLD,” “AUTO,” or “AUDI” and press ENTER to confirm.
5. Press MODE/ESC to return to the main menu.

This function dictates how the fixture will function if it loses DMX signal during normal operation. The default function is set to hold, in which the fixture will lock into the last DMX signal it received and remain in that position until it is turned off or begins receiving a new DMX signal. If the fixture is turned on without any DMX signal, the fixture will automatically go into sound-active mode. Available settings are: “Close” – Shutter flags will close. “Hold” – Fixture will remain at its last settings. “Auto” – Fixture will go into stand-alone mode, running the built-in program. “Music” – The fixture will go into sound-active mode.

4. RESE (RESET) MENU -

RESE

ALL - Resets all the motors in the unit.

SCAN - Resets the Pan and Tilt motors.

COLR (Color) - Resets the color motors.

GOBO - Resets the gobo motors.

SHTR - Resets the shutter motors.

OTHR - Reset all other motors

ALL

ALL

- When you activate this reset function, the fixture will begin to reset all motors.

1. Access the main menu.
2. Tap the UP button until “RESE” is displayed, press ENTER.
3. Tap the UP button until “ALL” is displayed, press ENTER.
4. The display will show “ON/OFF”. Press the UP button to select “ON” to reset the color motor.
5. Press ENTER to confirm
6. Press MODE/ESC to return to the main menu.

SCAN

SCAN

- When you activate this reset function, the fixture will only reset the Pan and Tilt mirror motor.

1. Access the main menu.
2. Tap the UP button until “RESE” is displayed, press ENTER.
3. Tap the UP button until “SCAN” is displayed, then press ENTER to confirm.
4. The display will show “ON/OFF”. Press the UP button to select “ON” to reset the color motor. Press ENTER to confirm.
5. Press MODE/ESC to return to the main menu.

COLR

COLR

- When you activate this reset function, the fixture will only reset the color

wheel motor.

1. Access the main menu.
2. Tap the UP button until “RESE” is displayed, press ENTER.
3. Tap the UP button until “COLR” is displayed, then press ENTER to confirm.
4. The display will show “ON/OFF”. Press the UP button to select “ON” to reset the color motor. Press ENTER to confirm.
5. Press MODE/ESC to return to the main menu.

GOBO



- When you activate this reset function, the fixture will only reset the gobo wheel motor.

1. Access the main menu.
2. Tap the UP button until “RESE” is displayed, press ENTER.
3. Tap the UP button until “GOBO” is displayed, press ENTER to confirm and begin the reset process.
4. Press MODE/ESC to return to the main menu.

OTHR

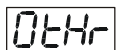

- When you activate this reset function, the fixture will only reset any motor not specified in the other reset commands previously listed.

1. Access the main menu.
2. Tap the UP button until “RESE” is displayed, press ENTER.
3. Tap the UP button until “OTHR” is displayed, then press ENTER to confirm.
4. The display will show “ON/OFF”. Press the UP button to select “ON” to reset the color motor. Press ENTER to confirm.
5. Press MODE/ESC to return to the main menu.

5. TIME MENU -



LIFE - Displays the fixtures total running time.

CLMP - Clears the lamp running time.

LIFE

 - With this function you can display the total running time of the fixture.

1. Access the main menu.
2. Tap the UP button until "TIME" is displayed, press ENTER.
3. Tap the UP button until "LIFE" is displayed, press ENTER.
4. Press MODE/ESC to return to the main menu.

CLMP

 - With this function you can clear the running time of the lamp. Note: ***Please clear the lamp time every time you replace the lamp.***

1. Access the main menu.
2. Tap the UP button until "TIME" is displayed, press ENTER.
3. Tap the UP button until "CLMP" is displayed, press ENTER.
4. Press MODE/ ENTER, the display will show "ON/OFF".
5. Press the UP button to select "ON" to activate this function, or "OFF" to deactivate this function.
6. Press ENTER to confirm.
7. Press MODE/ESC to return to the main menu.

6. RPAN MENU

 - This menu function will reverse the mirror PAN movements.

1. Access the main menu.
2. Tap the UP button until "RPAN" is displayed, press ENTER.
3. The display will show "ON/OFF".
4. Press the UP button to select "ON" to activate this function, or "OFF" to deactivate this function.
5. Press ENTER to confirm.
6. Press MODE/ESC to return to the main menu.

7. RTLT MENU

rtlt - This menu function will reverse the mirror TILT movements.

1. Access the main menu.
2. Tap the UP button until “RTL” is displayed, press ENTER.
3. The display will show “ON/OFF”.
4. Press the UP button to select “ON” to activate this function, or “OFF” to deactivate this function.
5. Press ENTER to confirm.
6. Press MODE/ESC to return to the main menu.

8. FINE MENU

FINE - This menu item switches between 16 bit (fine) and 8 bit (coarse) modes. When this function is turned on the fixture will operate in 16 bit (fine) mode. When functioning in 16 bit mode the fixture will use 16 DMX channels, when the 16bit function is turned off the fixture will use 14 DMX channels. To access the Fine menu follow the procedure below:

1. Access the main menu.
2. Tap the UP button until “FINE” is displayed, press ENTER.
3. The display will show “ON/OFF”.
4. Press the UP button to select “ON” to activate this function, or “OFF” to deactivate this function.
5. Press ENTER to confirm.
6. Press MODE/ESC to return to the main menu.

9. DEGR MENU -

dtgr - This menu function will toggle between the 630° and 540° for pan movement. When this function is turned on, the fixture will operate with a pan movement of 540°.

1. Access the main menu.
2. Tap the UP button until “DEGR” is displayed, press ENTER.
3. The display will display “630/540”.
4. Press the UP or DOWN button to select 630° or 540° for the pan movement angle, the default is 540°.
5. Press ENTER to confirm.

6. Press MODE/ESC to return to the main menu.

10. MIC MENU

 - This function allows for electronic control of the internal microphone's sound sensitivity.

1. Access the main menu.
2. Tap the UP button until "MIC" is displayed and press ENTER.
3. The display will show "M-XX" (Where XX represents a value between 00 & 99).
4. Use the UP and DOWN button to adjust the mic sensitivity, 99 being the highest.
5. Press ENTER to confirm and lock your new setting in place.
6. Press MODE/ESC to return to the main menu.

11. DISPLAY MENU

 - This menu function will control the various on-board display features.

 **VALU** – This function will display the DMX value of each channel as it is adjusted through the use of a DMX console.

1. Access the main menu.
2. Tap the UP button until "DISP" is displayed.
3. Press ENTER, the display will show "VALU".
4. Press ENTER, once again "d-00" will be displayed.
5. Press ENTER to confirm.
6. Press MODE/ESC to return to the main menu.

 **D ON** – This function will turn the display off after the has gone two seconds without any menu activity.

1. Access the main menu.
2. Tap the UP button until "DISP" is displayed.
3. Press ENTER, the display will show "VALU".
4. Tap the UP button until "D-ON" is displayed and tap the ENTER button.

Press the UP button to select "ON" to activate this function, or "OFF" to deactivate this function. When set "OFF", this function will turn the display off after the display has gone

two seconds without any menu activity.

5. Press ENTER to confirm.
6. Press MODE/ESC to return to the main menu.

FLIP

FLIP – This function will reverse the display readout by 180°.

1. Access the main menu.
2. Tap the UP button until “DISP” is displayed.
3. Press ENTER, the display will show “VALU”.
4. Tap the UP button until “FLIP” is displayed and tap the ENTER button.
5. Press the UP button to select “ON” to activate this function, or “OFF” to deactivate this function.
6. Press ENTER to confirm.
7. Press MODE/ESC to return to the main menu.

13. SPEC MENU – *This menu option access all the special functions listed below.*

RDMX - Allows DMX address to be changed via and external DMX controller.

SPOT - This provides a spot beam for better lamp optimization.

DFSE (Default) - Resets the unit to all default settings.

FEED - This function turn the DMX correction feature “ON” (default) or “OFF.”

FANS- Changes the functionality of the built-in fans.

VER (Version) - Displays the software version.

ADJU – Calibration functions

RDMX

rdm

– This function allows the DMX address to remotely be adjusted from a DMX console. This setting requires special settings for both the controller and the fixture.

RDMX is on by default. Follow the procedure listed below to access the RDMX functions:

Fixture Settings:

1. Access the main menu.
2. Tap the UP button until “SPEC” is displayed, press ENTER.
3. Tap the UP button until “RDMX” is displayed, press ENTER.

4. The display will show "ON/OFF."
5. Press the UP button to display "ON" to activate this function, or "OFF" to deactivate this function.
6. Press ENTER to confirm.
7. Press MODE/ESC to return to the main menu.

Controller Settings:

1. Set the DMX value of channel 1 to a value of 7.
2. Set the DMX value of channel 2 to a value of 7 or 8. When channel 2 is set to "7" you can adjust the starting address between 1 and 255. When set to "8" you can adjust the starting address between 256 and 511.
3. Use channel 3 to set your desired DMX starting address. **For example:** If you want to set the starting address to 57, set channel 1 to a value of "7," set channel 2 to a value of "7" and use channel 3 to set your address to 57 by selecting a channel value of 57. Example 2: If you want to set the starting address to 420, set channel 1 to a value of "7," channel 2 to "8" and channel 3 to "164" (256+164=420).
4. **Wait for approximately 20 seconds for the unit to complete the address reset function.**

SPOT



– This function allows you to optimize the lamp without the use of an external DMX controller. In this mode, the device will not react to any control signal.

1. Access the main menu.
2. Tap the UP button until "SPEC" is displayed, press ENTER.
3. Tap the UP button until "DFSE" is displayed, press ENTER.
4. The display will show "ON/OFF."
5. Press the UP button to display "ON" to activate this function, or "OFF" to deactivate this function.
6. Press ENTER to confirm.
7. Press MODE/ESC to return to the main menu.

DFSE

DFSE - With this function you can restore the factory default settings of the fixture. All settings will be set back to the default values. Any edited scenes will be lost. When restoring the factory settings the unit must be set to the address that the unit was in when you started editing. **When you confirm this function, the fixture will begin to reload the original factory settings.**

1. Access the main menu.
2. Tap the UP button until “SPEC” is displayed, press ENTER.
3. Tap the UP button until “DFSE” is displayed, press ENTER.
4. The display will show “ON/OFF.”
5. Press the UP button to display “ON” to activate this function, or “OFF” to deactivate this function.
6. Press ENTER to confirm.
7. Press MODE/ESC to return to the main menu.

FEED

FEED - Use this function to activate the pan/tilt error correction.

1. Access the main menu.
2. Tap the UP button until “SPEC” is displayed, press ENTER.
3. Tap the UP button until “FEED” is displayed, press ENTER.
4. The display will show “ON/OFF.”
5. Press the UP button to display “ON” to activate this function, or “OFF” to deactivate this function.
6. Press ENTER to confirm.
7. Press MODE/ESC to return to the main menu.

FANS

FANS - This function is used to change the functionality of the internal cooling fans.

Follow the procedure below to access the fan menu:

1. Access the main menu.
2. Tap the UP or DOWN button until “SPEC” is displayed, press ENTER.

3. Tap the UP or DOWN button until “FANS” is displayed, press ENTER.
4. The display will show “HIGH/AUTO”.
5. Press UP or DOWN button to select “HIGH” or “AUTO”.
6. Press ENTER to confirm.
7. Press MODE/ESC to return to the main menu.

VER

 - Use this function to display the Software version of the unit.

1. Access the main menu.
2. Tap the UP button until “SPEC” is displayed, press ENTER.
3. Tap the UP button until “VER” is displayed, press ENTER.
4. The display will show “V-1.0,” the display may also show, “V-2.0,” “V-9.9” etc.
5. Press ENTER or MODE/ESC to exit.

ADJU

 - This function is used to calibrate the various internal motors in the event the internal homing mechanism become slightly out of adjustment. This function is protected with a password to prevent unauthorized personal from tampering with the fixture. To enter the calibration menu follow the steps below:

1. Access the main menu.
2. Tap the UP or DOWN buttons until “ADJU” is displayed, then press ENTER.
3. Tap the UP or DOWN buttons until “CODE” is displayed, then press ENTER.
4. The display will show “CXXX”, were as XXX represents the calibration password. The calibration password is “C050.” Use the UP or DOWN buttons to enter the proper password.
5. Once the proper password is entered the display will read “CHXX”, were as “XX” represents the fixture channel number, in the case of the E Spot Led™ 1 ~ 16.
6. Select the desired channel to be calibrated by pressing the UP or DOWN buttons and then ENTER to confirm.
7. The display will then read “xxxx”, were “xxxx” stands for the calibrate values.
8. Adjust the desired calibration value between –128 and 127 by pressing the UP and DOWN. As you scroll up and down through the calibration values you will notice slight changes in the wheel or motor you are attempting to calibrate.

9. Once you reach your desired calibration press ENTER to confirm and lock in your calibration.

14. EDIT MENU

Ed It - This menu item allows you to write a program into the fixture's internal memory (EEPROM) via the control panel or via an external DMX controller.

SEPR- Select program to be edit.

STEP (S-01 - S-48) - These are the steps slots that you write your programs into. There are a total of 48 steps.

STXX (SC01 – SC48) - These are the scenes that are stored in your program. There are a total of 48 scenes. C-01 - C-11 (Channel 1 - Channel 11) – Represents the total fixture channels for each scene that can be edited.

TIME (Time) - Running time of the entire program.

CEDT - Edit program using a external controller.

REC – Auto save function.

RUN – Program test mode.

REC

- Records scenes automatically from any external DMX controller and stores them inside the fixtures built-in memory. These scenes can then be recalled without the use of an external controller.

1. Access the main menu.
2. Tap the UP or DOWN buttons until “EDIT” is displayed, then press ENTER.
3. Tap the UP or DOWN buttons until “REC” is displayed, then press ENTER.
4. After entering the REC function the display will read “RE.XX,” where as “XX” represents the scene number in the internal memory to which the scene will be stored.
5. Press the UP or DOWN buttons to select the desired scene number.
6. When you reach the scene number you wish to store the scene to, press ENTER to confirm and lock the scene into the fixture's memory.
7. Press MODE/ESC to return to the main menu.

SEPR

 - With this function you can Select program to be edit.

1. Access the main menu.
2. Tap the UP button until “EDIT” is displayed, press ENTER.
3. Tap the UP button until “SEPR” is displayed, press ENTER.
4. The display shows “IP01,” this indicates the first step of your program. You can call up to “IP08” scenes in “AUTO.” For example.
5. Press ENTER to save and MODE/ESC to exit.

STEP

 - With this function you can program the number of steps in your individual Program.

1. Access the main menu.
2. Tap the UP button until “EDIT” is displayed, press ENTER.
3. Tap the UP button until “STEP” is displayed, press ENTER.
4. The display shows “S-01,” this indicates the first step of your program. You can call up to 48 scenes in “Run.” For example; if “S-05” is displayed, it means that the scene will “RUN” the first 5 scenes you saved in “Edit.”
5. Press ENTER to save and MODE/ESC to exit.

SC01

 - This function allows you to choose the total number of scenes in your internal program.

1. Access the main menu.
2. Tap the UP button until “EDIT” is displayed, press ENTER.
3. Tap the UP button until “SC01” is displayed.
4. The display indicates “SC01,” this stands for the first scene of your program. You may recall up to 48 scenes. For example, if you choose “SC05,” and then select the “Run” function, the first 5 scenes you saved in “Edit” mode will run.
5. Press ENTER to save and MODE/ESC to exit.

Editing procedure 1: Using the control board only.

1. Access the main menu.
2. Tap the UP button until “EDIT” is displayed and press ENTER.
3. The display will show “SC-01”, this stands for the scene number. For example, “SC-01” is displayed, it means you will be editing scene 1, press ENTER. You can change the scene number by tapping the UP button.
4. Press ENTER, the display will show “C-01,” this represents the channel number. If “C-01” is displayed, you will be editing the fixture’s channel 1 value of the selected scene, press ENTER. You can change the channel number by tapping the UP button.
5. The display will show the DMX value for the channel that is being edited. It will be displayed as “11XX,” it stands for Channel 11 of the editing scene, the DMX value is “XX.”
6. Adjust the DMX value by tapping the UP button, until you get the expected effect for this channel.
7. Press ENTER to enter the editing of the other channels of the scene.
8. Repeat steps 5-8, until you finish setting all the DMX values for all the channels of this scene, each scene can have 16 channels maximum.
9. Once all the channels are completed, the display will begin to flash “TIME,” this indicates the time needed to run this scene.
10. Press ENTER to edit the time needed, the display shows “TXXX” , “XXX” represents the time needed to run this scene. For example, “T002” means scene 1 needs 0.4 seconds to run, “T-15” means this scene needs 3.0 seconds to run. Note: “XX” is always 0.2 seconds not one second.
11. Adjust the time needed by tapping the UP button.
12. Press ENTER to save the settings for the scene you are editing, the display will change to the next scene automatically.
13. Repeat steps 3-12 to edit other scenes, you can edit and save 48 scenes maximum.
14. Press MODE/ESC to exit and save your edited scene into the fixtures internal

memory. The number of steps can be defined under “EDIT” and the scenes can be called up under “Run.” To run the scenes see page 30.

Editing procedure 2: Using an external controller.

1. Call up the first scene in your controller now.
2. Select “SC01” by pressing the UP or DOWN buttons.
3. Press MODE/ESC, the display shows “SC01”.
4. Press MODE/ESC, the display shows “C-01”.
5. Select "**CEDT**" by pressing the UP or DOWN buttons.
6. Press MODE/ESC, the display shows "OFF".
7. Press UP, the display will read "ON".
8. Press MODE/ESC, the display shows "SC02". You successfully downloaded the first scene.
9. Adjust the Step-time as described above.
10. Call up the second scene in your controller now.
11. Repeat steps 5-11 until all desired scenes are downloaded.
- 12.** Press MODE/ESC to exit. The number of steps can be defined under “STEP” and the scenes can be called up under “RUN.”

RUN

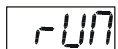

- This function allows you to “RUN” the user-installed program. You can set the number of steps under Step (S-01- S-48). You can edit the individual scenes under Edit.

1. Access the main menu.
2. Tap the UP button until “EDIT” is displayed, press ENTER.
3. Tap the UP button until “RUN” is displayed, press ENTER.
4. The display will show “ON/OFF”.
5. Press the UP button to display “ON” to activate this function, or “OFF” to deactivate this function.
6. Press MODE/ESC to return to the main menu.

9. DMX ADDRESSING

Setting the DMX address - After the fixture is turned “ON” it will immediately complete a reset process that test all the fixture’s functions. When the reset process concludes the LCD will display the fixture’s current DMX address. If the fixture is not receiving a DMX signal, the display will flash continuously. To set or adjust a DMX address, please follow the procedure below:

1. Toggle through the menu by pressing the Up and Down buttons until the display reads “Addr=XXX.” Tap the enter button to make changes to the address.
2. While the display is flashing use the “UP” and “DOWN” buttons to select a new address. Once the new address has been selected, lock the new address into the fixture’s memory by pressing the “ENTER” button.

The DMX address is non-volatile and will remain in the fixture’s memory even when the power to the unit is switched off. Memory is backed-up and retain by an internal power source that should last about five years

Remote DMX addressing (RDMX) / Address Via DMX- This function allows the DMX address to be changed remotely from a DMX console. This setting requires special settings for both the controller and the fixture. This function may be turned on and off, and is “ON” be default. Follow the procedure listed below to access the RDMX functions:

Fixture Settings:

8. Access the main menu and use the UP or DOWN to get to the “Personality” menu, then press ENTER
9. Once in the “Personalities” menu, tap the UP or Down to get to the “Status Settings “ menu, press ENTER.
10. Once in the “Status Settings” tap the UP or Down to get to the “Address via DMX” function and press ENTER.
11. “Address via DMX” is the function that turns the RDMX function on and off. Press ENTER and be sure the function is turned on.
12. Press the UP button to display “ON” to activate this function, or “OFF” to deactivate this function.

13. Press ENTER to confirm.
14. Press MODE/ESC to return to the main menu.

Controller Settings:

6. Set the DMX value of channel 1 to a value of 7.
7. Set the DMX value of channel 2 to a value of 7 or 8. When channel 2 is set to "7" you can adjust the starting address between 1 and 255. When set to "8" you can adjust the starting address between 256 and 511.
8. Use channel 3 to set your desired DMX starting address. **For example:** If you want to set the starting address to 57, set channel 1 to a value of "7," set channel 2 to a value of "7" and use channel 3 to set your address to 57 by selecting a channel value of 57. Example 2: If you want to set the starting address to 420, set channel 1 to a value of "7," channel 2 to "8" and channel 3 to "164" (256+164=420).
9. **Wait for approximately 20 seconds for the unit to complete the address reset function.**

10. DMX CHANNEL TRAITS:

The chart below details the channel layout for 14 DMX channels (default).

In 8bit mode the “Pan Fine” and “Tilt Fine” channels are not used, thus converting the fixture into a 12-channel DMX fixture.

%	1 Pan	2 Pan High Resolution	3 Tilt	4 Tilt High Resolution	5 Color	6 Rota. Gobo	7 Gobo Rotation	8 Prism/gobo Macros	9 Prism Rotation	10 Focus	11 Strobe	12 Dimming	13 Auto Scan speed	14 Program
100%														
75%														
50%														
25%														
0%														

CHANNEL 1: Pan Movement (max. 540° or 630° User Selectable)

CHANNEL 2: 16bit Pan Movement (pan fine)

CHANNEL 3: Tilt Movement (max. 265°)

CHANNEL 4: 16bit Tilt Movement (tilt fine)

CHANNEL 5: Color Wheel

CHANNEL 6: Gobos rotating

CHANNEL 7: Rotating gobo

CHANNEL 8: Prism rotating

CHANNEL 9: Rotating prism

CHANNEL 10: Focus

CHANNEL 11: Strobe (0-13Hz), Shutter close/open function + random strobe

CHANNEL 12: Dimmer (Intensity) Control

CHANNEL 13: Speed Control (Pan/Tilt movement, blackout selection)

CHANNEL 14: Special (program control + lamp on, motor reset, lamp switch off)

DMX channel function and values:

Mode/Channel			Value	Function
St	Ba	Ex		
1	1			PAN Movement 8bit
			0-255	Pan Movement By 540/630
2				Pan Fine 16bit
			0-255	Fine control of Pan movement
3	2			TILT Movement 8bit
			0-255	Tilt Movement By 270
4				Tilt Fine 16bit
			0-255	Fine control of Tilt movement
5	3			Color Wheel
			0-14	Open / white
			15-29	Color1
			30-44	Color2
			45-59	Color3
			60-74	Color4
			75-89	Color5
			90-104	Color6
			105-119	Color7
			120-127	Color8
			128-189	Forwards rainbow effect from fast to slow
			190-193	No rotation
194-255	Backwards rainbow effect from slow to fast			
6	4			Rotating gobos, cont. rotation
			0-9	Open
			10-19	Rotating gobo 1
			20-29	Rotating gobo 2
			30-39	Rotating gobo 3
			40-49	Rotating gobo 4
			50-59	Rotating gobo 5
			60-69	Rotating gobo 6
			70-79	Rotating gobo 7
			80-95	Rotating gobo 1 shake
			96-111	Rotating gobo 2 shake
			112-127	Rotating gobo 3 shake
			128-143	Rotating gobo 4 shake
144-159	Rotating gobo 5 shake			

			160-175	Rotating gobo 6 shake
			176-191	Rotating gobo 7 shake
			192-255	Rotating gobo wheel cont. rotation slow to fast
7	5			Rotating gobo index, rotating gobo rotation
			0-127	Gobo indexing
			128-189	Forwards gobo rotation from fast to slow
			190-193	No rotation
			194-255	Backwards gobo rotation from slow to fast
			Rotating prism, Prism / Gobo macros:	
8	6		0-31	Open
			32-63	3 facet prism
			64-95	Infinite (Trapezoid) prism
			96-127	5 facet prism
			128-135	Macro 1
			136-143	Macro 2
			144-151	Macro 3
			152-159	Macro 4
			160-167	Macro 5
			168-175	Macro 6
			176-183	Macro 7
			184-191	Macro 8
			192-199	Macro 9
			200-207	Macro 10
			208-215	Macro 11
			216-223	Macro 12
			224-231	Macro 13
	232-239	Macro 14		
	240-247	Macro 15		
	248-255	Macro 16		
			Rotating prism index, rotating prism rotation:	
9	7		0-127	Prism indexing
			128-189	Forwards prism rotation from fast to slow
			190-193	No rotation
			194-255	Backwards prism rotation from slow to fast
10	8			Focus:
			0-255	Continuous adjustment from far to near
11	9			Shutter, strobe
			0-31	Shutter closed

			32-63	No function (shutter open)
			64-95	Strobe effect slow to fast
			96-127	No function (shutter open)
			128-159	Pulse-effect in sequences
			160-191	No function (shutter open)
			192-223	Random strobe effect slow to fast
			224-255	No function (shutter open)
12	10			Dimmer (intensity)
			0-255	Intensity 0 to 100%
13	11			Speed pan/tilt movement
			0-225	Max to min speed
			226-235	Movements trigger blackout
			236-245	Wheel changes trigger blackout
			246-255	No function
14	12			Reset, internal programs
			0-19	Color change normal
			20-39	Color change to any position
			40-59	No function
			60-79	No function
			80-84	All motors reset
			85-87	Scan motors reset
			88-90	Colors motors reset
			91-93	Gobo motors reset
			94-96	No function
			97-99	Other motor reset
			100-119	Internal program 1
			120-139	Internal program 2
			140-159	Internal program 3
			160-179	Internal program 4
			180-199	Internal program 5
			200-219	Internal program 6
			220-239	Internal program 7
			240-255	Auto program by music

11. ERROR CODES:

When power is applied, the unit will automatically enter a “reset/test” mode. This mode brings all the internal motors to a home position. If there is an internal problem with one or more of the motors an error code will flash in the display in the form of “XXEr” where XX will represent a function number. For example, when the display shows “0Er,” it means there is some type of error with the Pan motor. If there are multiple errors during the start-up process they will all flash in the display. For example: if the fixtures has errors on channel 1, channel 2, and channel 5 all at the same time, you will see the error message “01Er”, “02Er,” and “05Er” flash repeated 5 times.

If an error does occur during the initial start-up procedure the fixture will self-generate a second reset signal and try to realign all the motors and correct the errors, if the error persists after a second attempt a third attempt will be made.

If after a third attempt all the errors have not been corrected the fixture will make the following determinations: 1) 3 or more errors - The fixture cannot function properly with three or more errors therefore the fixture will place itself in a stand-by mode until subsequent repairs can be made. 2) Less than 3 errors - The fixture has less than 3 errors, therefore most other functions will work properly. The fixture will attempt to operate normally until the errors can be corrected by a technician. The errors in question will remain flashing in the display as a reminder of internal errors.

PAN Error: The yoke is not located in the default position after start-up or after a reset command. This message will appear after a fixture reset if the pan’s magnetic-indexing circuit malfunctions (sensor failed or magnet is missing) or there is a motor failure (defective motor or a defective motor IC drive on the main PCB). This error may also be displayed if the head/yoke was blocked during a reset function.

TILT Error: This message will appear after a fixture reset if the tilt’s magnetic-indexing circuit malfunctions (sensor failed or magnet is missing) or there is a motor failure (defective motor or a defective motor IC drive on the main PCB). This error may also be displayed if the head was blocked during a reset function.

Color-wheel error:

The color wheel is not located in the default position after start-up or after a reset command. This message will appear after a fixture reset if the color wheel's magnetic-indexing circuit malfunctions (sensor failed or magnet is missing) or there is a stepper motor failure (defective motor or a defective motor IC drive on the main PCB).

Rotating gobo-wheel error:

The gobo-wheel is not located in the default position after start-up or after a reset command. This message will appear after a fixture reset if the gobo wheel's magnetic-indexing circuit malfunctions (sensor failed or magnet is missing) or there is a stepper motor failure (defective motor or a defective motor IC drive on the main PCB).

Rotating gobo indexing error:

The gobo is not located in the default position after start-up or after a reset command. This message will appear after a fixture reset if the gobo positioning magnetic-indexing circuit malfunctions (sensor failed or magnet is missing) or there is a stepper motor failure (defective motor or a defective motor IC drive on the main PCB).

Prism-wheel error

This message will appear after the reset of the fixture and if the magnetic-indexing circuit malfunctions (sensor failed or magnet missing) or the stepping-motor is defective (or its driver circuit on the main PCB). The Prism wheel is not located in the default position after the reset.

Focus-error

This message will appear after the reset of the fixture and if the magnetic indexing circuit malfunctions (sensor failed or magnet missing) or the stepping-motor is defective (or its driver circuit on the main PCB). The focus motor is not located in the default position after the reset.

12. CLEANING AND MAINTENANCE

The following points have to be considered during the inspection:

1. Be sure all screws and fasteners are securely tightened at all times. Loose screws may fall out during normal operation resulting in damage or injury as larger parts could fall.
2. There must not be any deformations on the housing, lenses, rigging hardware and rigging points (ceiling, suspension, trussing). Damaged rigging points or unsecured rigging could cause the unit to fall and seriously injure a person.
3. All mechanical parts and motors should not show any traces of serious wear and should rotate freely.
4. Electric power supply cables must not show any damage, material fatigue or sediments. Never remove the ground prong from the power cable.

Further instructions depending on installation and usage have to be adhered to by a skilled installer and any safety problems should be addressed before attempting operation.



CAUTION!

Disconnect from mains before starting maintenance operation.

We recommend frequent cleaning of the fixture to ensure operational longevity and crisp light output. When cleaning, please use a moist, lint-free cloth. Never use alcohol or solvents.

There are no user serviceable parts inside this fixture with the exception of the lamp. Please refer all other service related issues to an authorized Elation service technician.

Should you decide to service the fixture yourself please order genuine Elation parts directly from Elation.

13. Photometric Data:

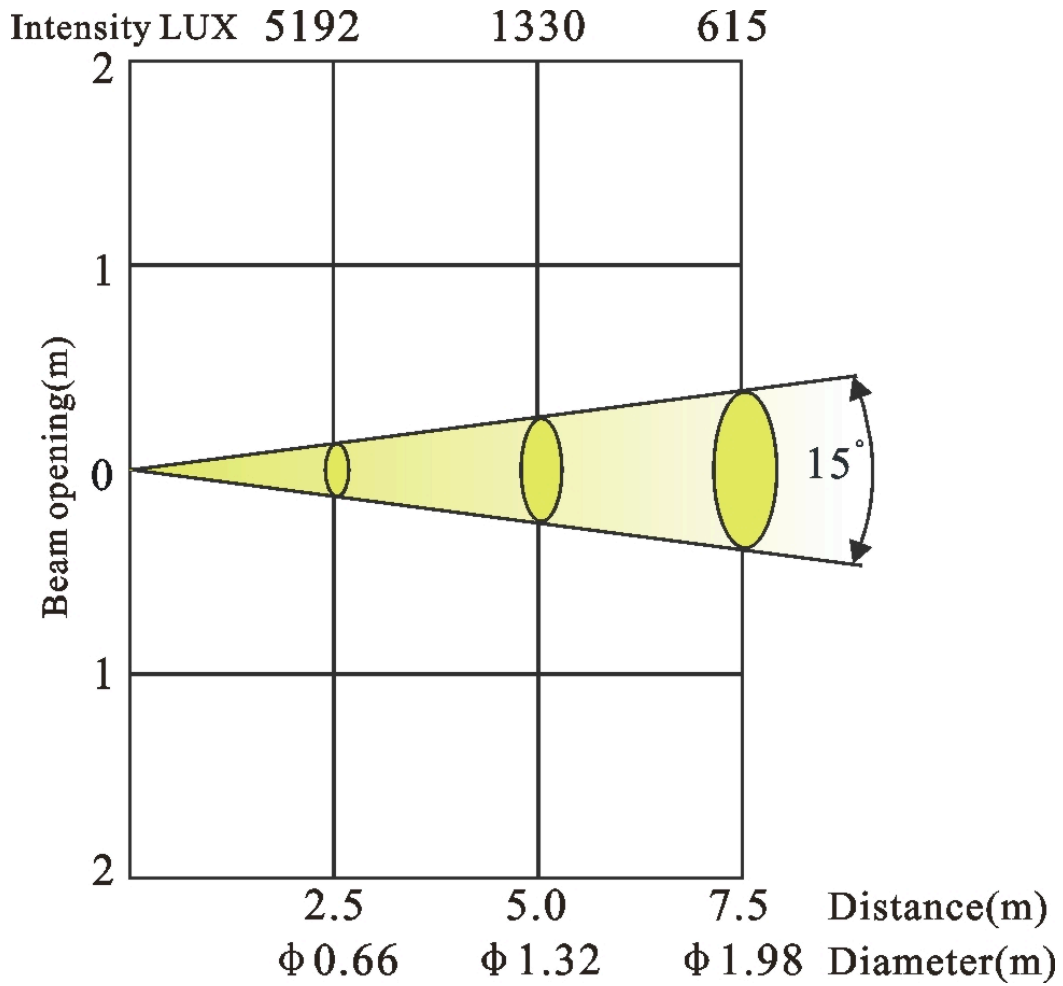

17. GOBOS:

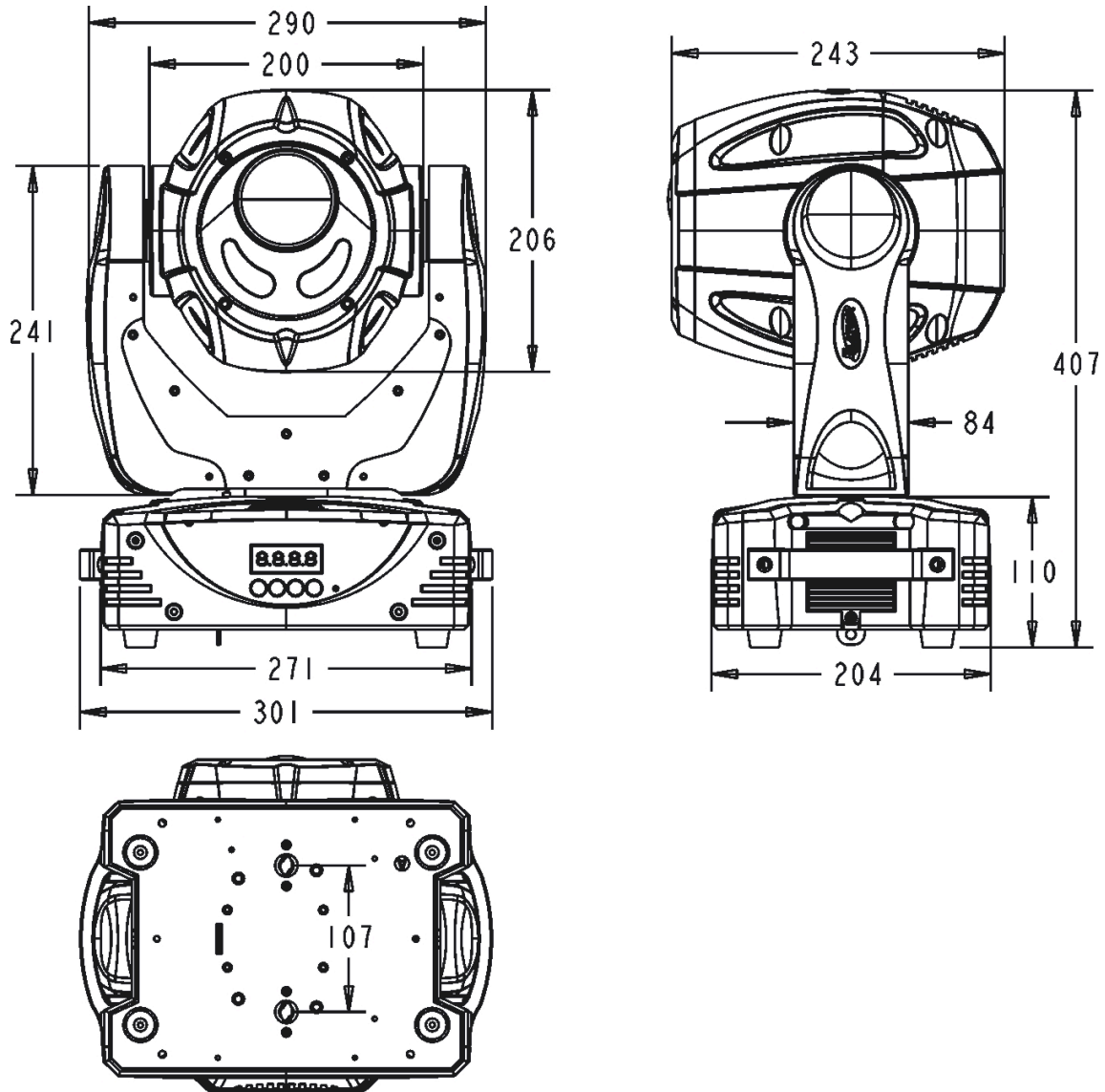

15. DIMENSIONAL DRAWINGS:

16. CIRCUIT SCHEMATICS

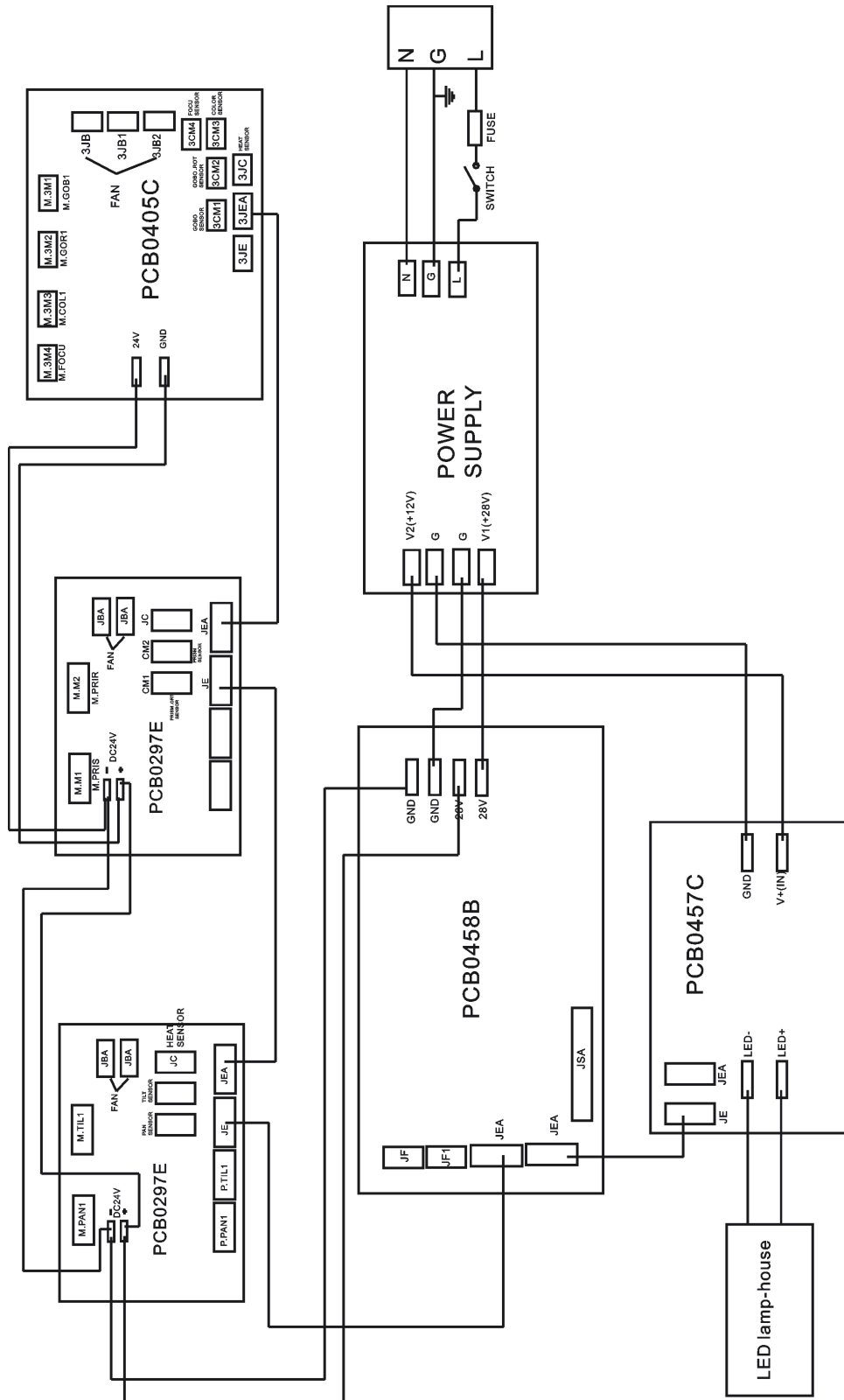

17. TECHNICAL SPECIFICATIONS

Power supply	
Power Requirements	100~240v 50/60Hz Internal Voltage Taps
Fuse protection	120V = 3.15A/250V, GMA (5x20mm fine-wire fuse) 220V = 2A/250V, GMA (5x20mm fine-wire fuse)
Power Consumption	180w (maximum @ at full power)
Light Source	
LED	CTB-90-W
Life Time	60,000 Hours (Rated)
Optical	
Parabolic glass reflector	
15° standard objective	
Lens anti-reflex	
Color Mixing	
8 dichroic filters plus white, half-color compatible	
Gobos	
Gobo-wheel: 4 interchangeable rotating gobos plus "open", 3 glass Gobo	
Gobo outside diameter 26.9 mm, image size 24 mm	
Gobo thickness: glass = 1 mm, steel = 0.4 mm	
Shutter / Strobe / Dimmer	
Strobe-effect with variable speed 0 - 13 flashes per second	
Continuously dimming 0% - 100%	
Prism	
Rotating 3-face prism, rotating and variable in speed	
Focus	
Motor driven focus from near to far away	
DMX Channels	
14 (16bit – default)	
DMX Drive	
Standard DMX-512, 3 pole & 5 pole XLR; [+] = Pin 3 [-] = Pin 2 [Ground] = Pin 1. Starting DMX [001].	
Pan / Tilt	
Pan- movement	630° in max. 2.0 seconds, 16 bit resolution
Tilt- movement	270° in max. 1.5 seconds, 16 bit resolution
Weights and measures	
Dimensions	11.42" (H) x 9.57" (W) x 16.02" (D) ~ Head vertical
Weight (net)	23 Lbs

Please Note: Specifications and improvements in the design of this unit and this manual are subject to change without any prior written notice.

Elation Professional®
6122 S. Eastern Ave.
Los Angeles, CA. 90040
323-582-3322 / 323-832-9142 fax
www.ElationLighting.com /
Info@ElationLighting.com