

# Design Spot 575E

Elation Professional  
4295 Charter Street  
Los Angeles, Ca 90058  
[www.elationlighting.com](http://www.elationlighting.com)

Rev. 7/24/07

## Contents

1. General Information.....	3
a. Introduction.....	3
b. Unpacking.....	3
c. Customer Support.....	3
d. Warranty Registration.....	4
e. Discharge Lamp Warning.....	4
2. Safety Instructions.....	6
3. Features.....	8
4. General Guidelines.....	9
5. Lamp Installation.....	10
a. Lamp installation.....	10
b. Lamp optimization.....	11
6. Mounting and Installation.....	13
a. Mounting Positions.....	13
b. Mounting Points.....	14
c. Securing.....	15
7. Understanding DMX.....	16
a. DMX Connections.....	16
b. DMX Terminator.....	17
c. 3-Pin to 5-Pin Conversion.....	18
d. DMX Addressing.....	18
8. Display Indicators.....	20
9. Fixture Menu.....	21
a. Menu functions.....	23
10. DMX Channel Traits.....	39
a. DMX Channel Values.....	40
11. Error Codes.....	45
12. Cleaning and Maintenance.....	48
13. Warranty.....	49
14. Photometric Data.....	51
15. Gobo Patterns.....	52
16. Dimensional Drawings.....	53
17. Circuit Schematic.....	54
18. Technical Specifications.....	55

## 1. GENERAL INFORMATION

**INTRODUCTION:** Congratulations, you have just purchased one of the most innovative and reliable lighting fixtures on the market today! The Design Spot 575E,™ has been designed to perform reliably for years when the guidelines in this booklet are followed. Please read and understand the instructions in this manual carefully and thoroughly before attempting to operate this unit. These instructions contain important information regarding safety during use and maintenance.

**UNPACKING:** Thank you for purchasing the Design Spot 575E™ by Elation Professional®. Every Design Spot 575E™ has been thoroughly tested and has been shipped in perfect operating condition. Carefully check the shipping carton for damage that may have occurred during shipping. If the carton appears to be damaged, carefully inspect your unit for damage and be sure all accessories necessary to operate the unit have arrived intact. In the event damage has been found or parts are missing, please contact our customer support team for further instructions. Please do not return this unit to your dealer without first contacting customer support at the number listed below.

**CUSTOMER SUPPORT:** Elation Professional® provides a customer support line, to provide set up help and to answer any question should you encounter problems during your set up or initial operation. You may also visit us on the web at [www.elationlighting.com](http://www.elationlighting.com) for any comments or suggestions. For service related issue please contact Elation Professional®. Service Hours are Monday through Friday 9:00 a.m. to 5:00 p.m. Pacific Standard Time.

Voice: (323) 582-3322

Fax: (323) 582-3108

E-mail: [support@elationlighting.com](mailto:support@elationlighting.com)

Forum: [www.ElationLighting.com/forum](http://www.ElationLighting.com/forum)

**Warning!** To prevent or reduce the risk of electrical shock or fire, do not expose this unit to rain or moisture.

**Caution!** There are no user serviceable parts inside this unit. Do not attempt any repairs yourself, doing so will void your manufactures warranty.

*Please do not discard the shipping carton in the trash. Please recycle whenever possible.*

**WARRANTY REGISTRATION:** The Design Spot 575E™ carries a two year (730 days) limited warranty. Please fill out the enclosed warranty card to validate your purchase. All returned service items whether under warranty or not, must be freight pre-paid and accompany a return authorization (R.A.) number. The R.A. number must be clearly written on the outside of the return package. A brief description of the problem as well as the R.A. number must also be written down on a piece of paper and included in the shipping container. If the unit is under warranty, you must provide a copy of your proof of purchase invoice. Items returned without a R.A. number clearly marked on the outside of the package will be refused and returned at customer's expense. You may obtain a R.A. number by contacting customer support at (323) 582-3322.

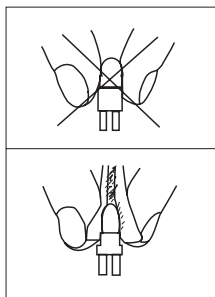

**DISCHARGE LAMP WARNING:** This fixture is fitted with a discharge lamp, which is highly susceptible to damage if improperly handled. Never touch the lamp with your bare hands, as the oil from your hands will shorten lamp life. Also, never move the fixture until the lamps have had ample time to cool. Remember, lamps are not covered under warranty conditions.

This fixture emits intense UV radiation, which is harmful to the eyes and skin. The intense luminance of the lamp can cause severe damage to the retina. Never operate this fixture with the protective covers removed, these covers have been specially designed to shield against UV radiation.

**Epileptic Warning:** *Those suffering from epilepsy should avoid looking directly into the lamp at all times.*

Avoid switching the fixture on and off repeatedly in short intervals, as this will reduce lamp life and intensity.

To achieve the intensity associated with discharge lamps, these lamps use a gas sealed in a high-pressure environment to emit a brilliant output. Due to the high pressure involved with the construction of the lamp, the lamp may explode during prolonged extensive use. This risk is increased with age; added care is encouraged when dealing with older lamps. Thus,

lamp should always be replaced at the end of their recommended duty cycle. Extreme caution should be used when operated this or any fixture fitted with a gas discharge lamp.

**Never open this fixture while in use!**

During the initial operation of this fixture, a light smoke or smell may emit from the interior of the fixture. This is a normal process and is caused by excess paint in the interior of the casing burning off from the heat associated with the lamp and will decrease gradually over time.

This device falls under protection-class 1. Therefore it is essential that the device be grounded properly.

All electrical connections must be performed by qualified personnel.

Be sure the available voltage matches the voltage requirements of the unit.

Be sure the power cord is never crimped or damaged. If the power cord is damaged, replace it immediately with a new one of similar power rating.

Always disconnect from main power before performing any type of service or any cleaning procedure.

Only handle the power cord by the plug. Never pull out the plug by tugging the wire portion of the cord.

***Please be aware that damages caused by manual modifications to the device are not subject to warranty.***

## 2. SAFETY INSTRUCTIONS



The Design Spot 575E™ is an extremely sophisticated piece of electronic equipment. To guarantee a smooth operation, it is important to follow the guidelines in this manual. The manufacturer of this device will not accept responsibility for damages resulting from the misuse of this fixture due to the disregard of the information printed in this manual.

1. Always be sure that the fan and the air inlets remain clean and are never blocked. Allow about 6" (15cm) between this fixture and other devices or a wall to allow for proper cooling.
2. Never touch the fixture during normal operation. This can cause severe personal injuries and/or damage to the fixture.
3. Be sure to unplug the DESIGN SPOT 575E™ from the power outlet before performing any service related issues.
4. Lamp Replacement; Allow at least 30 minutes after disconnecting main power before you open the DESIGN SPOT 575E™. To prevent personal injury, never touch the lamp if you are not absolutely sure it has cooled.
5. Never look directly into the lamp beam. You risk injury to your retina, which may induce blindness.
6. Be sure to track and record the lamp running time. The lamp should be changed at the end of the specified lamp life, regardless of lamp output. You may also have to change the lamp if it shows any deformations or damage. The same is with all glass components, color filters, lenses and mirrors.
7. For safe operation, follow the Installation guide described in chapter two of this manual. Operating the DESIGN SPOT 575E™ without suited safety aids such as safety cables or clamps can increase the risk of damage and/or personal injury.
8. Installation should only be performed by qualified and certified personal.
9. When mounting this fixture, use only the original rigging parts included with this fixture. Any structural modification will void the original manufactures warranty and

may increase the risk of damage and/or personal injury.

10. To reduce the risk of fire or shock, do not expose this fixture to rain or moisture.
11. Do not attempt to operate this fixture if the power cord has become damaged or frayed.

**Important Notice:** Damages resulting from the disregard of safety and general user instructions found in this user manual are not subject to any warranty claims.



**CAUTION!**

Never touch the device during operation!  
The housing may heat up



**CAUTION!**

Never look directly into the light source,  
as sensitive persons may suffer an epileptic shock.

### 3. FEATURES

- Pan 630° or 540° (User selectable) / Tilt 265°
- Built-In Macros (Color, Gobo, Prism)
- 3 operation mode: DMX Controlled, Stand-Alone or Sound Activated
- Color Wheel: 8 colors plus white (including UV filter), with rainbow effect
- CMY Variable Color Mixing
- Easy to Navigate On-Board LCD Menu (may be turned 180°)
- Animation Effect Wheel
- Two Gobos Wheels:
  - Rotating gobo wheel with 7 rotating gobos plus open, all gobos can be easily replaceable and gobo indexing
  - Static gobo wheel with 7 static gobos plus open with different speed gobo shaking and gobo indexing
- Strobe Effect: 0~10 flashes per second or random strobe
- Motorized Focus (Near to Far)
- Prism and Prism Rotation, with 16 prism macros (Indexable)
- Bright Phillips Gold MSR 575/2 SA DE Lamp (575w / 7200K / 750Hrs / 43,000Lm)
- Linear Dimmer from 0%~100%
- Electronic, Switching Power Supply (90v~240v)
- Variable, Linear Frost Filter (0% ~ 100%)
- RDMX (Remote DMX addressing from any DMX console)
- Auto test for all functions
- Automatic Pan/Tilt Correction
- Built-in Iris (5% ~ 100% - Seamless), with Iris Pulse Effect
- Motorized Linear Zoom (15° ~ 30°)
- Glass Dichroic Reflector for Even Lamp Output
- USITT DMX-512 Compliant
  - 24 DMX Channels (16bit Operation)
  - 22 DMX Channels (8bit Operation)
- 8 User Assignable Program Presets - Internal Program: Edit and save programs to the incorporated EEPROM. Maximum of 48 scenes.



## 4. GENERAL GUIDELINES

This fixture is a professional lighting effect designed for use on stage, in nightclubs, in theatres, etc. Do not attempt operation or installation without a proper knowledge on how to so.

This fixture was designed for indoor use only.

Consistent operational breaks may ensure that the fixture will function properly for many years to come.

Do not shake the fixture around. Avoid brute force when installing or operating the device.

While choosing an installation location, please be sure that the fixture will not be exposed to extreme heat, moisture or dust. The minimum distance between the fixture and a wall or flat surface should be at least .5 meter (about 1.5ft).

Always install the fixture with an appropriate safety cable. When installing the fixture in a suspended environment always be to use mounting hardware no less than M10 x 25 mm, also be sure the hardware is insert in the pre-arranged screw holes in the base of the fixture.

When using the quick release “Omega” cam-lock system, be sure the four quick lock fasteners are locked in the quick lock holes correctly.

Do not attempt to operate this fixture until you have familiarized yourself with its functions.

Do not permit operation by persons not qualified for operating this type of theatrical fixture, most damages are the result of operations by nonprofessionals.

Please use the original packaging to transport the fixture in for service.

## 5. LAMP INSTALLATION INSTRUCTIONS

For a proper and safe lamp change, please read this chapter carefully and follow all instructions.

### Safety Regulations

- Disconnect the unit's main power supply.
- Allow the unit to cool for at least 20 minutes before attempting any type of service.
- Before you put the Design Spot 575E™ into operation be sure all covers have been replaced, otherwise you risk damage to the retina and expose to UV radiation!
- Replace the lamp with an approved replacement type. Be sure to follow all the lamp handling procedures included with your new lamp. Never handle the new lamp with your bare hands, the oils from your skin may damage the lamp. Always replace with the lamp with a lamp that meets the original lamp specification, failure to do so may damage the unit and will void your manufactures warranty.

### Installation Procedure:

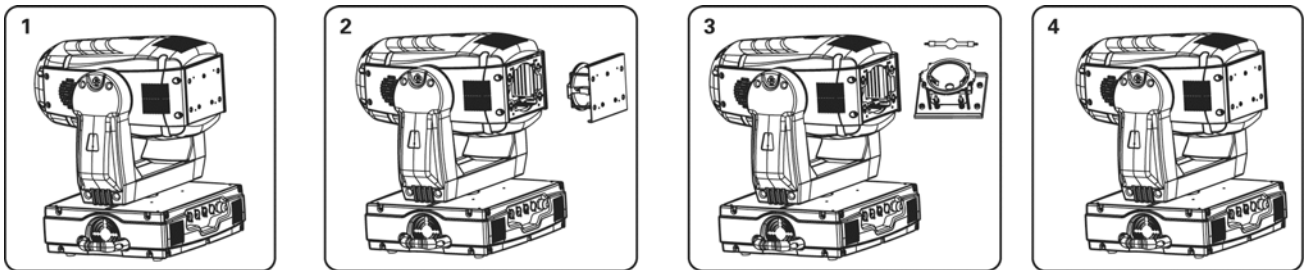

1. Set the fixture on a flat surface and remove the four screws labeled "A" "B," "C," and "D" found on the back plate of the head assembly.
2. Gently pull out the lamp/socket assembly to access the lamp.
3. Gently remove the old lamp by grasping it by metal ends.
4. Insert the new lamp securely, locking the lamp in place as illustrated in the diagram on the next page. Orientate the lamp filler tube towards the backside of the reflector. Before reassembling the unit, be sure the new lamp is securely seated in the lamp socket. Always be sure to only use specified lamp types! (MSR 575 SA/2 DE lamp or equivalent).

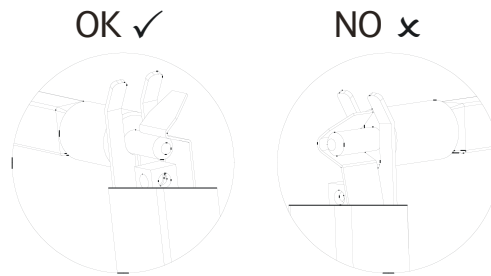

5. Once the lamp has been inserted into the socket, gently slide the socket assembly back into place and secure with the four retaining screws.
6. Reset the lamp run time in the system menu.
7. Always be sure to optimize the lamp after lamp replacement.



### CAUTION!

Do not operate this device with open cover

### **Lamp Optimization**

The lamp orientation and optimization must be adjusted after every lamp change. This procedure centers the lamp in the reflector. Proper optimization will increase lamp life and ensure a bright, crisp, and even output. Improper optimization may add a yellow tint to the lamp output and reduce intensity. The minimum deviation amount is 1.0mm. Running the fixture within a lower deviation can cause damage to the lamp and/or lens.

The **Design Spot 575E™** lamp holder is aligned at the factory. However, due to slight imperfections in all lamps, fine adjustments will improve light performance. Please follow the procedure below for proper lamp optimization:

1. Using either a DMX controller or the control panel on the unit (see “SPOT” in the fixture menu on page 33), strike the lamp and focus the light on a flat surface (beam open, white, no gobo, no effect).
2. Center the hot-spot (the brightest part of the beam) using the 3 adjustment screws labeled 1, 2, and 3 as illustrated on the next page. Turn one screw at a time to drag the hot-spot diagonally across the projected image. If you cannot detect a hot-spot, adjust the lamp until the light is even.

3. To reduce a hot-spot, pull the lamp in by turning all three screws clockwise a 1/4-turn at a time until the light is evenly distributed.
4. If the light is brighter around the edge than it is in the center, or if light output is low, the lamp is too far back in the reflector. "Push" the lamp out by turning each of the adjustment screws ("**1, 2, 3**") counterclockwise turn until the light is bright and evenly distributed.

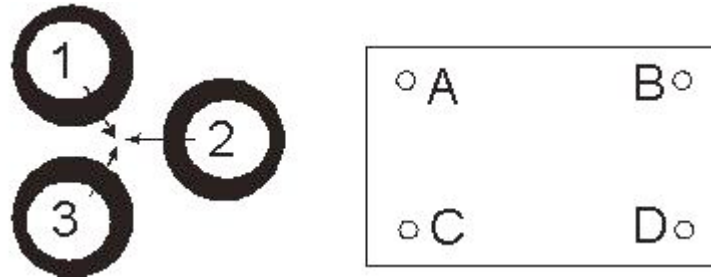

Please remember that a MSR 575 SA/2 DE lamp is not a hot-restrike lamp therefore, you must wait approximately 15 minutes before you can attempt to strike the lamp once it has been turned off.

## 6. MOUNTING AND INSTALLATION

### **Cautions:**

For added protection mount the fixtures in areas outside walking paths, seating areas, or in areas where the fixture might be reached by unauthorized personnel.

Before mounting the fixture to any surface, make sure that the installation area can hold a minimum point load of 10 times the device's weight.

Fixture installation must always be secured with a secondary safety attachment, such as an appropriate safety cable.

Never stand directly below the device when mounting, removing, or servicing the fixture.



**CAUTION!**  
Before taking into operation for the first time, the installation has to be approved by an expert.



**CAUTION!**  
When installing the device, make sure there is no highly inflammable material within a distance of min. 0,5m

### ***Mounting***

The DESIGN SPOT 575E™ is fully operational in two different mounting positions, hanging upside-down from a ceiling, or set on a flat level surface (see illustration on next page). Be sure this fixture is kept at least 0.5m away from any flammable materials (decoration etc.). Always use and install the supplied safety cable as a safety measure to prevent accidental damage and/or injury in the event the clamp fails.



**Refer to regulations BGV C1 (formerly VBG 70) and DIN VDE0711-217 for proper installation in Europe To ensure proper installation, only qualified staff should attempt installation.**

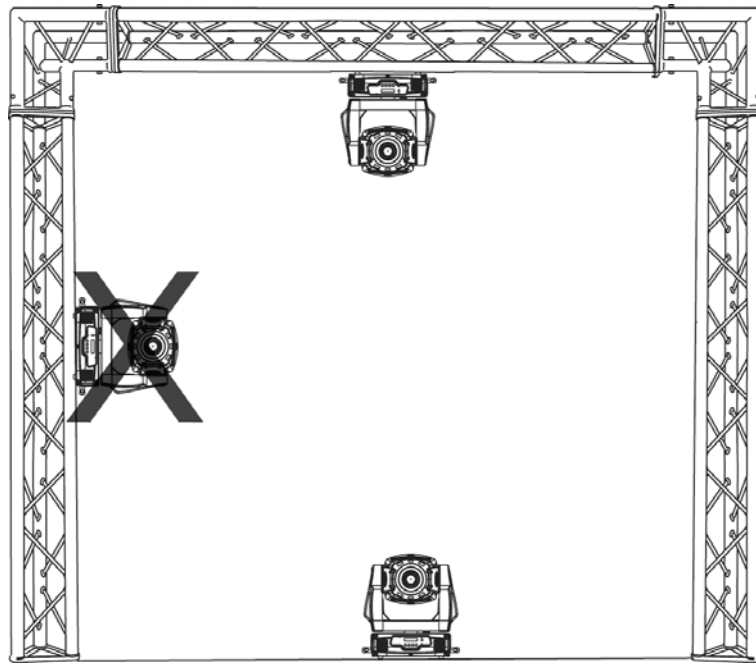

### ***Mounting points***

Overhead mounting requires extensive experience, including amongst others calculating working load limits, a fine knowledge of the installation material being used, and periodic safety inspection of all installation material and the fixture. If you lack these qualifications, do not attempt the installation yourself. Improper installation can result in bodily injury.



**CAUTION!**  
Be sure all electrical connections are performed by a qualified electrician.

Be sure to complete all rigging and installation procedures before connecting the main power cord to the appropriate wall outlet.

### **Clamp Mounting**

The Design Spot 575E™ provides a unique mounting bracket assembly that integrates the hanging yoke as well as the safety cable rigging point in one unit (see the illustration below). When mounting this fixture to truss be sure to secure an appropriately rated clamp to the hanging yoke using a M10 screw fitted through the center hole of the hanging yoke. As an

added safety measure be sure to attached at least one properly rated safety cable to the fixture using on of the safety cable rigging point integrated in the bracket assembly

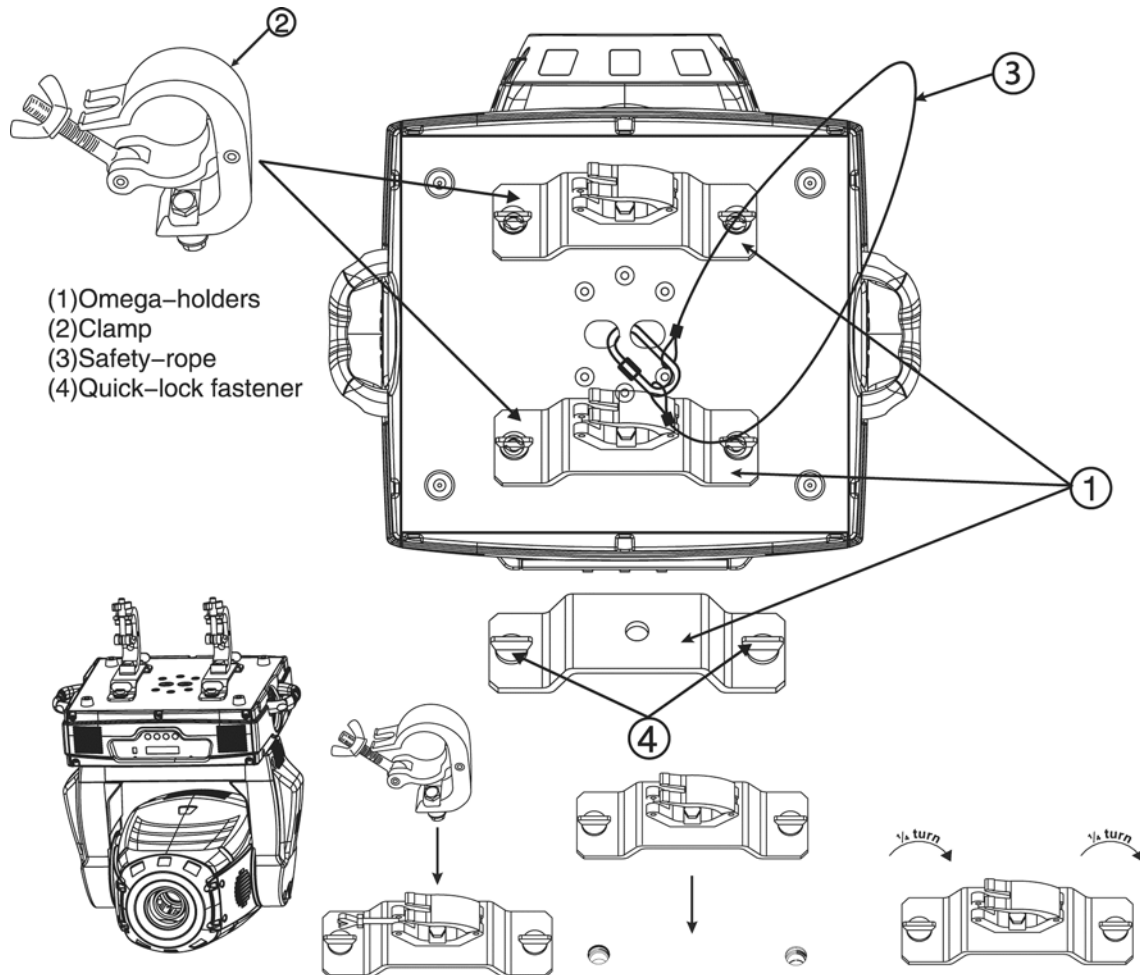

### Securing the DESIGN SPOT 575E™

Regardless of the rigging option you choose for your Design Spot 575E™ always be sure to secure your fixture with a safety cable. The fixture provides a built-in rigging point for a safety cable on the hanging bracket as illustrated above. Be sure to only use the designated rigging point for the safety cable and never secure a safety cable to a carrying handle.

## 7. UNDERSTANDING DMX

**DMX-512:** DMX is short for Digital Multiplex. This is a universal protocol used by most lighting and controller manufactures as a form of communication between intelligent fixtures and controllers. A DMX controller sends DMX data instructions from the controller to the fixture. DMX data is sent out as serial data that travels from fixture to fixture via the DATA “IN” and DATA “OUT” XLR terminals located on all DMX fixtures (most controllers only have a DATA “OUT” terminals). DMX Linking: DMX is a language allowing all makes and models of different manufactures to be linked together and operate from a single controller, as long as all fixtures and the controller are DMX compliant. To ensure proper DMX data transmission, when using several DMX fixtures try to use the shortest cable path possible. The order in which fixtures are connected in a DMX line does not influence the DMX addressing. For example; a fixture assigned a DMX address of 1 may be placed anywhere in a DMX line, at the beginning, at the end, or anywhere in the middle. Therefore, the first fixture controlled by the controller could be the last fixture in the chain. When a fixture is assigned a DMX address of 1, the DMX controller knows to send DATA assigned to address 1 to that fixture, no matter where it is located in the DMX chain.

**Data Cable (DMX Cable) Requirements (For DMX and Master/Slave Operation):** The Design Spot 575E™ can be controlled via DMX-512 protocol. The Design Spot 575E™ is a 24 channel DMX fixture. The DMX address is set electronically using the controls on the LCD menu. Your fixture and your DMX controller require a standard 3-pin or 5-pin XLR connector for data input and data output (Figure below is of a 3-Pin XLR connector). If you are making your own cables, be sure to use standard two conductor shielded cable (This cable may be purchased from your Elation dealer or at most professional lighting retailers). Your cables should be made with a male and female XLR connector on either end of the cable. Also, remember that DMX cable must be daisy chained and cannot be split. unless you are using an approved DMX splitter such as the Elation Opto Branch 4™ or DMX Branch/4™.

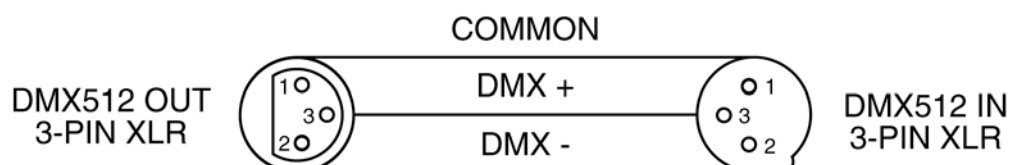



Be sure to follow the pin configuration chart below when making your own cables. Do not use the ground lug on the XLR connector. Do not connect the cable's shield conductor to the ground lug or allow the shield conductor to come in contact with the XLR's outer casing. Grounding the shield could cause a short circuit and erratic behavior.

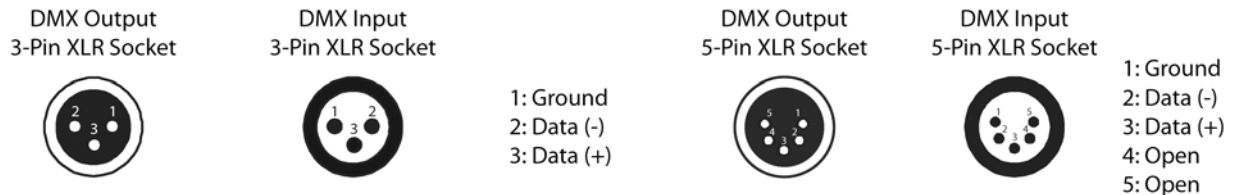

### DMX-512 control connection

Connect the provided XLR cable to the female 3-pin XLR output of your controller and the other side to the male 3-pin XLR input of the moving head (Please refer to the diagram below.). You can chain multiple moving heads together through serial linking. Always be sure daisy chain your in and out data connections, never split or “Y” your DMX connections unless you are using an approved DMX splitter such as the Elation Opto Branch 4™ or DMX Branch/4™.

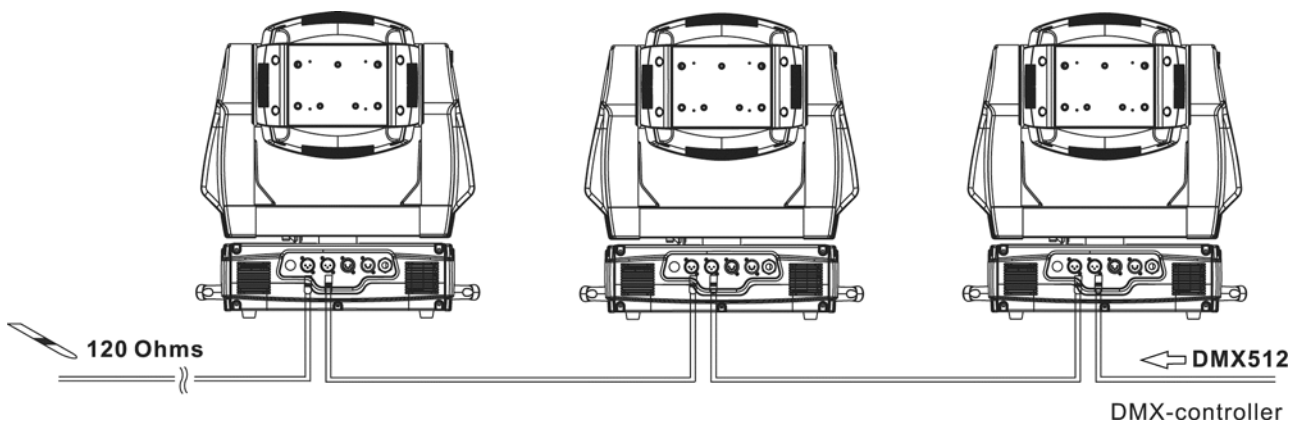

### DMX-512 connection with DMX terminator

When longer runs of cable are used, you may need to use a terminator on the last fixture to avoid erratic behavior. A terminator is a 90-120 ohm 1/4 watt resistor that is connected between pins 2 and 3 of a male XLR connector (DATA + and DATA -). This fixture is inserted in the female XLR connector of the last fixture in your daisy chain to terminate the line. Using

a cable terminator (Elation part number Z-DMX/T) will decrease the possibilities of erratic behavior.

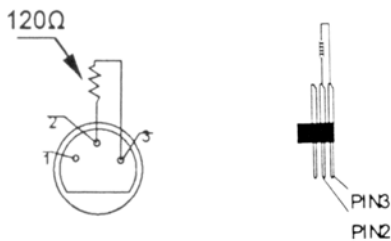

Termination reduces signal errors and avoids signal transmission problems and interference. It is always advisable to connect a DMX terminal, (Resistance 120 Ohm 1/4 W) between PIN 2 (DMX-) and PIN 3 (DMX +) of the last fixture.

### **Fixture DMX addressing;**

All fixtures should be given a DMX starting address when using a DMX controller, so the correct fixture responds to the correct control signal. This digital starting address is the channel number from which the fixture starts to “listen” to the digital control information sent out from the DMX controller. The allocation of this starting DMX address is achieved by setting the correct DMX address on the digital display located on the head of the fixture.

You can set the same starting address for all fixtures or a group of fixtures, or set different address for each individual fixture. Be advised that setting all you fixtures to the same DMX address will subsequently control all fixtures in the same fashion, in other words, changing the settings of one channel will affect all the fixtures simultaneously.

If you set each fixture to a different DMX address, each unit will start to “listen” to the channel number you have set, based on the quantity of control channels (DMX channels) of each fixture. That means changing the settings of one channel will only affect the selected fixture.

In the case of the Design Spot 575E™, which is a 24 channel fixture, you should set the starting DMX address of the first unit to 1, the second unit to 25 (24 + 1), the third unit to 49 (24 + 25), and so on.

**Note:** During start-up the Design Spot 575E™ will automatically detect whether a DMX data signal is being received or not. If DMX data signal is being received, the display will show "A.XXX" (XXX representing the actual DMX address). If the fixture is not receiving a DMX

signal the display will flash "**A.XXX**" (**XXX** representing the actual DMX address).

If your fixture is connected to a DMX controller and the display is flashing (not receiving a DMX signal), please check the following:

- The 3 PIN XLR plug (cable with DMX signal from controller) is not connected or is not inserted completely into the DMX input jack.
- The DMX controller is switched off or defective.
- The DMX cable or connector is defective.
- A DMX terminator has been inserted into the last fixture in your DMX chain.

## 8. Display LED Indicators.

The Design Spot 575E™ has two LED indicators on the display. These indicators are designed to give a quick visual indication of the fixtures' status. The illustration below details the functionality of the LED indicators.

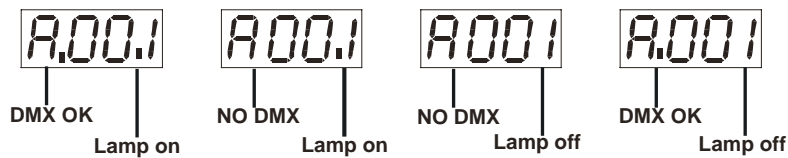

The first LED indicators represents DMX signal:

- If the indicators is on a clean DMX signal is present
- If the indicator is off there is no DMX signal present

The second LED indicator represents lamp condition:

- If the indicator is on the lamp is struck and in working condition
- If the LED indicator is off the lamp has not struck, has been turned off, or is bad.

## 9. FIXTURE MENU

**On-Board System Menu:** The DESIGN SPOT 575E™ comes with an easy to navigate system menu. This next section will detail the functions of each command in the system menu.

**LCD Control Panel:** The control panel located on the side of the fixture allows you to access the main menu and make necessary adjustments to the **Design Spot 575E™**. During normal operation, tapping the “**MODE/ESC**” key once will access the fixture’s main menu. Once in the main menu you can navigate through the different functions and access the sub-menus with the **Up** and **Down** buttons. Once you reach a field that requires adjusting, tap the **ENTER** button to activate that field and use the **UP** and **Down** button to adjust the field. Tapping the **Enter** button once more will confirm your setting. You may exit the main menu at any time without making any adjustments by tapping the **MODE/ESC** button.

Function Mode	Set DMX Address	A001~Axxx		DMX address setting
	Value Display	PAN Moving...		DMX value display
	Set To Slave	Slave1, Slave2, Slave3		Slave setting
	Auto Program	Master / Alone		Auto program
	Music Control	Master / Alone		Music control
Information	Time Information	Current Time	XXXX (Hours)	Total power run time
		Total Run Time	XXXX (Hours)	Fixture running time
		Total Lamp Time	XXXX (Hours)	Lamp running time
	Lamp Off Time	XXXX (Minute)	Lamp off time	
	Clear Lamp Time	ON/OFF	Reset lamp time	
Temperature Info	Base Temperature	XX °C/°F		Base temperature display
	Head Temperature	XXX°C/°F		Head temperature display
Software Version	Ver1.0		Display will readout current firmware version	

Lamp Control	Lamp On or Off	ON/OFF		Manual Lamp on/off Automatic lamp strike when power is applied Enables Lamp on via DMX Enables lamp off via DMX Lamp off if no DMX is present Lamp restart at temp. Lamp off at temp.
	Automatic La-On	ON/OFF		
	Lamp On Via DMX	ON/OFF		
	Lamp Off Via DMX	ON/OFF		
	Lamp Off No DMX	OFF, OFF~19M		
Lamp On at Temp.	45C, 20~79°C/°F		Lamp restart at temp. Lamp off at temp.	
Lamp Off at Temp.	130C, 80~139°C/°F			
Personality	Status Settings	Address via DMX	ON/OFF	Add via DMX
		No DMX Status	Auto/Music/Close/Hold	Auto run if no DMX
		Pan Reverse	ON/OFF	Pan Reverse movement
		Tilt Reverse	ON/OFF	Tilt Reverse movement
		Fine Resolution	ON/OFF	Fine resolution switch
	Pan Degree	630/540		Pan Degree Select
	Feedback	ON/OFF		Scan Feedback switch
	Movement Speed	Speed 1~ 4		Scan Mode Select
	Mic Sensitivity	70%, 0~99%		Microphone Sensitivity
	Fans Control	Auto Fans Speed		Automatic fan speed control
		High Fans Speed		Fans set to high speed
	Temperature C/F	Celsius Fahrenheit		Change temperature readout from C° to F°
	Initial Effect	PAN	PAN =XXX	User selectable PAN home (Start-up) position
	Reset Default	ON/OFF		Restore factory defaults

Reset Function	Reset All				Reset all motors
	Reset Pan&Tilt				Reset Pan and tile motors
	Reset Colors				Reset color wheel
	Reset Gobos				Reset gobo wheel motors
	Reset Shutter				Reset shutter and/or dimmer
Reset Others				Reset other motors	
Effect Adjust	Test Channel	PAN .....			Test the various functions of the fixture
	Manual Control	PAN	PAN =XXX		Allows the user manual control all functions of the fixture
	Calibrate Values	--Password--	Password=XXX		Allows manual calibration of internal effect motors. Password "050"
		Color wheel	Color wheel=XXX		0 ~ 255
Users Mode Set	User Mode	XXXXXX (Band) User Mode A User Mode B User Mode C			This mode changes the channel functions to match similar fixtures from different manufactures for easier control.
	Edit User Mode	PAN	PAN = CH01		Preset User modes
Edit Program	Select Programs	Auto Program Part 1 Auto Program Part 2 Auto Program Part 3	Program 1 ~ 10 Program 1 Program 1 ~ 10 Program 2 Program 1 ~ 10 Program 3		Allows the user to select from 1 of 10 internal programs
	Edit Program	Program 1 :	Program Test Step	("STEP XX")	Testing program

		Program 10	01=SCxxx Step 64=SCxxx		Program in loop Save and exit
Edit Scenes	Edit Scene 001 ~ Edit Scene 250		Pan, Tilt... --Scenes Time-- Input By Outside	Pan=xxx... TIME=xx.xs	Save and automatically return  Scene edit mode
Rec. Controller	XX~XX				Automatic scene record

### 1. DMX address setting

After applying power and the rest process the Design Spot 575™ LCD will display the fixture's current DMX. If the fixture is not receiving a DMX signal the display will flash continuously. To set or adjust a DMX address, please follow the procedure below:

1. Toggle through the menu by pressing the Up and Down buttons until the display shows "Set DMX Address." Tap the enter button to make changes to the address,.
2. While the current three-digit address is flashing, use the Up and Down buttons to select adjust the address. Lock your new address into the unit's memory by pressing the Enter button.

The DMX address is non-destructible and will remain in the fixture's memory even when power to the fixture has been switched off. Memory is backed-up and retained by an internal power source with a five year shelf life.

### 2. Display the DMX 512 value of each channel

With this function you can display the DMX 512 value of each channel. The display will automatically readout the changing DMX values as they are received.

### 3. Slave setting

With this function, you can define the device as slave for operation in Master/Slave mode.



#### 4. Auto Program

This function allows the internal programs to run. The desired program is selected in the “**Select program**” section of the control menu. You can set the number of steps under “**Edit program**”. You can edit the individual scenes under “**Edit scenes**”. With this function, you can run the individual scenes either automatically, i.e. with the adjusted Step-Time.

#### 5. Music control

With this function, you can run the internal program via sound.

### ***Information:***

#### 1. Time information

##### **Current time**

This function displays the running time of the fixture from the last power on. The display shows “XXXX”, where “XXXX” represents the number of hours the fixture has been running. This counter is automatically reset after every power-on.

##### **Machine on time**

This function tracks the total running time of the fixture from the very first start-up. Where “XXXX” represents the total number of running hours. This time is non-destructive and will remain in the fixtures memory indefinitely.

##### **Lamp on time**

This function tracks the total number of lamp running hours. Where “XXXX” represents the number of hours the lamp has been running. This counter should be reset after every lamp change.

##### **Lamp off time**

This function displays the running time of the lamp from the last power on. The display shows “XXXX”, where “XXXX” represents the number of hours the lamp has

been running since it was last struck. This counter is automatically reset after every power-on.

### **Clear lamp time**

This function resets the lamp “ON” time to zero. Please reset the lamp “ON” time at every lamp replacement. This procedure tracks the lamp running time so the lamp can be replaced at the end of it’s recommended duty cycle.

- Select “**Clear lamp time**” in the system menu.
- The LCD will display “ON” or “OFF.” Were “ON” will reset the lamp time.
- Press enter to confirm.
- Press the Mode/Esc-button to return to the main menu.

## **2. Temp. Info.**

**Base Temp** – This function will display the base temperature of the fixture.

**Inside head Temp** – This function will display the head temperature of the fixture.

## **3. Software version**

This function will display the current operating software version of the fixture.

- Select “**Software Version**” in the system menu.
- Press enter to confirm.
- The LCD will read “V-X.X”, “X.X” represents the version number, e.g. “V-1.0”, “V-2.6”.
- Use the UP and DOWN buttons to toggle through the software version of different IC’s.
- Press the Mode/Esc-button to return to the main menu.

## **LAMP CONTROL:**

### **1. Lamp on/off**

With this function you can switch the lamp on or off via the Control Board.

- Select "**Lamp on/off**" by turning the LCD controls.

- Press the LCD controls, the display shows “**ON**” or “**OFF**”.
- Turn the LCD controls to select “**ON**” if you wish to strike the lamp or “**OFF**” in order to switch it off.
- Press the LCD controls to confirm.
- Press the Mode/Esc-button in order to return to the main menu.

## 2. **Automatic La-On**

With this function you can select if the lamp will be switched on when switching the power on. Select “**ON**” by turning the LCD controls if you wish to enable this function or “**OFF**” if you don’t.

## 3. **Lamp on via external controller**

With this function you can select if you can switch the lamp on via an external controller. Select “**ON**” by turning the LCD controls if you wish to enable this function or “**OFF**” if you don’t.

## 4. **Lamp off via external controller**

With this function you can select if you can switch the lamp off via an external controller. Select “**ON**” by turning the LCD controls if you wish to enable this function or “**OFF**” if you don’t.

## 5. **Lamp Off if no DMX**

With this function you can select to switch off the lamp off automatically if there is no DMX signal). Select “**ON**” by turning the LCD controls if you wish to enable this function or “**OFF**” if you don’t.

## 6. **Lamp on at temp.**

With this function you can set the inside temperature from which the projector will restrike the lamp after automatic lamp shut off.

## 7. **Lamp off at temp.**

With this function you can set the inside temperature at which the projector will

automatically switch the lamp off. Turn the LCD controls to select the maximum inside temperature between 80° C and 139° C. Inside temperatures below 90° C are not critical. 90° C and more should lead to the lamp being switched off. Please note that the outside temperature should not exceed 45° C.

## **PERSONALITY:**

### **1. Status setting**

**A. Address via DMX** - This function allows the DMX address to remotely be adjusted from a DMX console. This setting requires special settings for both the controller and the fixture. RDMX is on by default. Follow the procedure listed below to access the RDMX functions:

#### ***Fixture Settings:***

1. Access the main menu.
2. Tap the UP button until “**Address via DMX**” is displayed, press ENTER.
3. Tap the UP button until “RDMX” is displayed, press ENTER.
4. The display will show “ON/OFF.”
5. Press the UP button to display “ON” to activate this function, or “OFF” to deactivate this function.
6. Press ENTER to confirm.
7. Press MODE/ESC to return to the main menu.

#### ***Controller Settings:***

1. Set the DMX value of channel 1 to a value of 7.
2. Set the DMX value of channel 2 to a value of 7 or 8. When channel 2 is set to "7" you can adjust the starting address between 1 and 255. When set to "8" you can adjust the starting address between 256 and 511.
3. Use channel 3 to set your desired DMX starting address. **For example:** If you want to set the starting address to 57, set channel 1 to a value of “7,” set channel 2 to a value of “7” and use channel 3 to set your address to 57 by selecting a channel value of 57. Example 2: If you want to set the starting address to 420, set channel 1 to a value of “7,” channel 2 to “8”

and channel 3 to "164" (256+164=420).

**4. Wait for approximately 20 seconds for the unit to complete the address reset function.**

- B. Run if no DMX** – This function dictates how the fixture will function if it loses DMX signal during normal operation. The default function is set to hold, in which the fixture will lock into the last DMX signal it received and remain in that position until it is turned off or begins receiving a new DMX signal. If the fixture is turned on without any DMX signal, the fixture will automatically go in to sound-active mode. Available settings are: “Close” – Shutter flags will close. “Hold” – Fixture will remain at its last settings. “Auto” – Fixture will go into stand-alone mode, running the built-in program. “Music” – The fixture will go into sound-active mode.
- C. Pan Reverse** - This function allows you to invert all pan movements. Use the Up and Down buttons to turn this function On and Off. Press the Enter button to accept the change or the Mode button to cancel and return to the main menu.
- D. Tilt Reverse** - This function allows you to invert all tilt movements. Use the Up and Down buttons to turn this function On and Off. Press the Enter button to accept the change or the Mode button to cancel and return to the main menu.
- E. Fine resolution** – This function changes the DMX channel operation from 8bit to 16bit.
- F. Pan Degree** – This function changes the maximum Pan resolution from either 540° or 630°. The default function is 540°.
- G. Feedback** – This function turns the feedback correction on or off. This function is set to on as default.

- H. Movement Speed** – This function changes the order of the DMX channels to more closely match similar fixtures from different vendors, thus allowing the user easier functionality when programming. There are four different mode variations.
- I. Mic Sensitivity** – This function make the internal microphone more or less sensitive to sound. This function only works in conjunction with the sound active modes. The default setting is 70% and setting range from 0 % to 99 %.
- 2. Fans Control** - This function is used to change the functionality of the internal cooling fans. The available selections are: 1) “AUTO” – The fans will automatically switch between low and high speeds depending on the internal operating temperature. 2) “HIGH” – The fans will run in high-speed mode regardless of operating temperature. 3) “LOW” – The fans will remain in low speeds regardless of internal operating temperature.
- 10. Temperature C/F** – This function changes the temperature unit readout from either the temperature Celsius or Fahrenheit.
- 11. Initial effect** - With this function, you can adjust with which value the respective channels will start.
- 12. Restore factory settings** - With this function you can restore the factory settings of the device. All settings will be set back to the default values (shaded). Any edited scenes will be lost.

### ***RESET-FUNCTIONS:***

This function allows the user to reset all motors or individual motors. The reset functions can be executed via the on-board menu functions or via a DMX using a DMX console.

## 1. *Effect Adjust*

Test function of each channel

With this function you can test each channel on its (correct) function.

Lamp adjustment (manual control)

With this function, you can adjust the lamp more easily. All effects will be canceled, the shutter opens and the dimmer intensity will be set to 100 %. With the individual functions, you can focus the light on a flat surface (wall) and optimize the lamp.

Calibrate values

With this function, you can calibrate and adjust the effect wheels to their correct positions.

The password of calibrate values is 050.

*Users mode set*

User mode

With this function, you can create user defined channel orders.

Edit User mode

With this function, you can adjust the preset user defined channel order.

*Edit program*

Select program

With this function, you can select the program for the Program Run.

Edit program

With this function, you can edit the internal programs.

Edit scenes

With this function, you can edit the scenes of the internal programs.

Auto scenes rec

The moving head features an integrated DMX-recorder by which you can transmit the

programmed scenes from your DMX-controller to the moving head. Adjust the desired scene numbers via the LCD controls (from – to). When you call up the scenes at your controller, they will automatically be transmitted to the moving head.



## 10. OPERATION

*Operating Modes: The Power Spot 700CMY™ can operate in three different modes. This next section will detail the differences in the operating modes.*

- **Stand alone mode** - The fixture will react to sound, chasing through the built-in programs.
- **Master/Slave mode** - You can daisy chain up to 16 fixtures together to get a synchronized light show without the need of an external controller. The fixtures will react to sound chasing to synchronized light show.
- **DMX control mode** - This function will allow you to control each individual fixtures traits with a standard DMX-512 controller such as the Elation® Show Designer 2.

**10.1 Universal DMX Control:** This function allows you to use a universal DMX-512 controller such as the Elation® DMX Operator II™ or Elation® Show Designer 2™ to control head movement, the color wheel, the shutter (strobe), and all other DMX traits. A DMX controller allows you to create unique programs tailored to your individual needs. The Power Spot 700CMY™ uses 16 DMX channels. See page 27 for detailed description of the DMX traits. To control your fixture in DMX mode, follow the set-up procedures on pages 13-15 as well as the set-up specifications that are included with your DMX controller. Use the controller's faders to control the various DMX fixture traits. This will allow you to create your own programs.

**9.1.1** Follow the instruction on page 18 to set the DMX address.

**9.2.2** For longer cable runs (more than a 100 feet) be sure to use a terminator on the last fixture.

**9.2.3** For help operating in DMX mode consult the manual included with your DMX controller.

**9.2 Stand-Alone Operation (Sound Active):** This mode allows a single fixture to run to the beat of the music. Only use this mode when running a single fixture, or when running several fixtures as individuals.

**9.2.1** Mount your fixture in a secure and stable manner.

- 9.2.2** Access the main menu and select the AUDI function, this will give you access to the audio submenu. See page 16 for the menu breakdown.
- 9.2.3** In the audio submenu choose the audio chase speed, fast or slow. Slow (ASLW) will trigger the chase sequence to every two beats, while fast (AFST) will trigger the chase impulse every beat. See page 16 for more details.
- 9.2.4** Be sure the Master (MSTR) function is switched “ON,” and the SVPT function is switched “OFF.”
- 9.2.5** Choose your room size. The size function allows you to choose a the approximate size of the room (NORM, BIG, MIDL, SMAL). The built-in programs will automatically adjust to your slection to optimize light output for your room.
- 9.2.6** Use the sound sensitivity knob on the side control panel to make the unit more or less sensative to sound. Turning the knob in clockwise direction will make the unit more sensetive to sound, while turning the knob counter-clockwise will make the unit less sensetive to sound. Note: This unit will react to the low frequencies of a sound source, tapping on the fixture or high pitched sound may not trigger the fixture.

**9.3 Master-Slave Operation (Sound Active):** This function will allow you to link up to 16 fixtures together and operate without a controller. The fixtures will be sound activated. In Master-Slave operation one fixture will act as the controlling fixture and the others will react to the controlling fixtures programs. Any fixture can act as a Master or as a Slave.

- 9.3.1** Using standard XLR microphone cables, daisy chain your fixtures together via the XLR connector on the rear of the fixtures. Remember the Male XLR connector is the input and the Female XLR connector is the output. The first fixture in the chain (master) will use the female XLR connector only - The last fixture in the chain will use the male XLR connector only. For longer cable runs we suggest a terminator at the last fixture.
- 9.3.2** Follow the same procedures listed in the previous Stand-Alone section. With two exceptions; Be sure the first unit in the chain is selected as the “master“ (MSTR) is turned on in the audio submenu. All other fixtures must be in “slave“ mode (SVPT) turned on in the audio submenu.

## 11. DMX CHANNEL TRAITS:

The chart below details the channel layout for 24 DMX channels (default).

*In 8bit mode the “Pan Fine” and “Tilt Fine” channels are not used, thus converting the fixture into a 22-channel DMX fixture.*

CHANNEL 1: Pan Movement (max. 630° or 540° User Selectable)

CHANNEL 2: 16bit Pan Movement (pan fine)

CHANNEL 3: Tilt Movement (max. 265°)

CHANNEL 4: 16bit Tilt Movement (tilt fine)

CHANNEL 5: Color Wheel

CHANNEL 6: Cyan Filter

CHANNEL 7: Magenta Filter

CHANNEL 8: Yellow Filter

CHANNEL 9: Gobo Wheel 1 (Rotating)

CHANNEL 10: Gobo Index, Gobo Rotation Speed/Direction (Gobo Wheel 1)

CHANNEL 11: Gobo Wheel 2 (Rotating)

CHANNEL 12: Gobo Index, Gobo Rotation Speed/Direction (Gobo Wheel 2)

CHANNEL 13: 3-Facet Prism Control

CHANNEL 14: Focus Control Motor (Near ~ Far)

CHANNEL 15: Variable Zoom

CHANNEL 16: Strobe (0-13Hz), and Shutter close/open function + random strobe

CHANNEL 17: Dimmer (Intensity) Control

CHANNEL 18: Iris (Closed to Open)

CHANNEL 19: Frost Filter (Minimum to Maximum)

CHANNEL 20: Animation (Rotation/Insert)

CHANNEL 21: CMY Speed

CHANNEL 22: Color Macros (CMY and Color Wheels)

CHANNEL 23: Speed Control (Pan/Tilt movement, blackout selection)

CHANNEL 24: Special (Auto program control + lamp on, motor reset, lamp switch off)

### ***DMX channel function and values:***

**Channel 1 - Pan movement 8bit:****Channel 2 - Pan fine 16bit****Channel 3 - Tilt movement 8bit:****Channel 4 - Tilt fine 16bit****Channel 5 - Color Wheel:**

0-13	Open / white
14-27	Red
28-41	Blue
42-55	Green
56-69	Yellow
70-83	Magenta
84-97	Orange
98-111	UV Filter
112-127	Pink
128-187	Forwards rainbow effect from fast to slow
188-193	No rotation
194-255	Backwards rainbow effect from slow to fast

**Channel 6 - Cyan Color Wheel:**

0-255	Cyan (0-white, 255-100% Cyan)
-------	-------------------------------

**Channel 7 - Magenta Color Wheel:**

0-255	Magenta (0-white, 255-100% magenta)
-------	-------------------------------------

**Channel 8 - Yellow Color Wheel:**

0-255	Yellow (0-white, 255-100% Yellow)
-------	-----------------------------------

**Channel 9 – Gobo Wheel 1 - rotating gobos:**

0-9	Open
10-19	Gobo 1
20-29	Gobo 2
30-39	Gobo 3
40-49	Gobo 4
50-59	Gobo 5
60-69	Gobo 6
70-89	Gobo 1 shake slow to fast
90-109	Gobo 2 shake slow to fast

110-129	Gobo 3 shake slow to fast
130-149	Gobo 4 shake slow to fast
150-169	Gobo 5 shake slow to fast
170-189	Gobo 6 shake slow to fast
190-255	Gobo Wheel Scroll – Continuous rotation slow to fast

**Channel 10 – Gobo Wheel 1- Indexing, rotation:**

0-127	Gobo indexing
128-187	Forwards gobo rotation from fast to slow
188-193	No rotation
194-255	Backwards gobo rotation from slow to fast

**Channel 11 – Gobo Wheel 2 – Rotating gobos:**

0-9	Open
10-19	Gobo 1
20-29	Gobo 2
30-39	Gobo 3
40-49	Gobo 4
50-59	Gobo 5
60-69	Gobo 6
70-89	Gobo 1 shake slow to fast
90-109	Gobo 2 shake slow to fast
110-129	Gobo 3 shake slow to fast
130-149	Gobo 4 shake slow to fast
150-169	Gobo 5 shake slow to fast
170-189	Gobo 6 shake slow to fast
190-255	Gobo Wheel Scroll – Continuous rotation slow to fast

**Channel 12 - Rotating gobo index, rotating gobo rotation:**

0-127	Gobo indexing
128-187	Forwards gobo rotation from fast to slow
188-193	No rotation
194-255	Backwards gobo rotation from slow to fast

**Channel 13 - 3 facet rotating prism, Prism / Gobo macros:**

0-3	Open
4-63	Clockwise rotation from fast to slow
64-67	No rotation
68-127	Counter-Clockwise rotation from slow to fast
128-135	Macro 1
136-143	Macro 2

144-151	Macro 3
152-159	Macro 4
160-167	Macro 5
168-175	Macro 6
176-183	Macro 7
184-191	Macro 8
192-199	Macro 9
200-207	Macro 10
208-215	Macro 11
216-223	Macro 12
224-231	Macro 13
232-239	Macro 14
240-247	Macro 15
248-255	Macro 16

**Channel 14 - Focus:**

0-255 Continuous adjustment from near to far

**Channel 15 – Variable Zoom - Seamless**

0-255 Zoom adjustment from small to big

**Channel 16 - Shutter, strobe:**

0-31	Shutter closed
32-63	No function (shutter open)
64-95	Strobe effect slow to fast
96-127	No function (shutter open)
128-159	Pulse-effect in sequences
160-191	No function (shutter open)
192-223	Random strobe effect slow to fast
224-255	No function (shutter open)

**Channel 17- Dimmer (intensity):**

0-255 Intensity 0 to 100%

**Channel 18 - Iris:**

0-191	Max. diameter to Min. diameter
192-223	Pulse closing fast to slow
224-255	Pulse opening slow to fast

**Channel 19 - Frost:**

0-191 Frost 0~100%

192-223	Pulse opening fast to slow
224-254	Pulse closing slow to fast
255	Max. Frost

**Channel 20 - Animation Wheel, rotating fire wheel:**

0-7	Open
8-255	Forwards rotation from fast to slow

**Channel 21 - Speed Of CMY And Dimmer:**

0-255	Speed Maximum to Minimum
-------	--------------------------

**Channel 22 - Color macros - CMY and color wheel:**

0-7	OFF
	128-135 Macro 16
8-15	Macro1
	136-143 Macro 17
16-23	Macro2
	144-151 Macro 18
24-31	Macro3
	152-159 Macro 19
32-39	Macro4
	160-167 Macro 20
40-47	Macro5
	168-175 Macro 21
48-55	Macro6
	176-183 Macro 22
56-63	Macro7
	184-191 Macro 23
64-71	Macro8
	192-199 Macro 24
72-79	Macro9
	200-207 Macro 25
80-87	Macro10
	208-215 Macro 26
88-95	Macro11
	216-223 Macro 27
96-103	Macro12
	224-231 Macro 28
104-111	Macro13
	232-239 Macro 29
112-119	Macro14
	240-247 Macro 30
120-127	Macro15
	248-255 Random CMY

**Channel 23 - Speed pan/tilt movement:**

0-225	Max to min speed
226-235	Blackout by movement
236-245	Blackout by all wheel changing
246-255	No function

**Channel 24 - Lamp on/off, reset, internal programs:**

0-19	Color change normal
20-39	Color change to any position
40-59	Lamp on
60-79	Lamp switch off
80-84	All motor reset
85-87	Scan motor reset
88-90	Colors motor reset
91-93	Gobo motor reset
94-96	Shutter & Dimmer motor reset
97-99	Other motor reset
100-119	Internal program 1 (scene1~8 of EPROM)
120-139	Internal program 2 (scene9~16 of EPROM)
140-159	Internal program 3 (scene17~24 of EPROM)
160-179	Internal program 4 (scene25~32 of EPROM)
180-199	Internal program 5 (scene33~40 of EPROM)
200-219	Internal program 6 (scene41~48 of EPROM)
220-239	Internal program 7 (scene49~56 of EPROM)
240-255	Music Control (scene of Program 1)



## 12. FUSE REPLACEMENT

**Caution:** Always replace with the exact same type fuse, unless otherwise specified by an authorized Elation® service technician. Replacing with anything other than the specified part can damage your unit and will void your manufacturer's warranty.

**Warning:** If you continue to blow fuses, STOP using the fixture. Contact customer support for further instructions, you may have to return the unit for servicing. Continuing to use the unit may cause serious damage.

**Fuse Replacement:** Locate and remove the unit's power cord from the main power supply. Once the cord has been removed locate the fuse holders located on the side panel near the power input connection. Using a flat-head screwdriver unlock the fuse holder from its' housing by turning the holder in a counter-clockwise direction. Once the fuse holder has been unlocked, pull back on the fuse holder to expose the fuse. Gently pull out the bad fuse and discard it properly and replace it with an exact match. Reassemble in reverse order.

## 11. ERROR CODES:

When power is applied, the unit will automatically enter a “reset/test” mode. This mode brings all the internal motors to a home position. If there is an internal problem with one or more of the motors an error code will flash in the display in the form of “XXEr” where as XX will represent a function number. For example, when the display shows “02Er,” it means there is some type of error with the channel 2 motor. If there are multiple errors during the start-up process they will all flash in the display. For example: if the fixtures has errors on channel 1, channel 2, and channel 5 all at the same time, you will see the error message “01Er”, “02Er,” and “05Er” flash repeated 5 times.

If an error does occur during the initial start-up procedure the fixture will self-generate a second reset signal and try to realign all the motors and correct the errors, if the error persists after a second attempt a third attempt will be made.

If after a third attempt all the errors have not been corrected the fixture will make the following determinations: 1) 3 or more errors - The fixture cannot function properly with three or more errors therefore the fixture will place itself in a stand-by mode until subsequent repairs can be made. 2) Less than 3 errors - The fixture has less than 3 errors, therefore most other functions will work properly. The fixture will attempt to operate normally until the errors can be corrected by a technician. The errors in question will remain flashing in the display as a reminder of internal errors.

### **Pan Er**

(PAN-yoke movement error) This message will appear after the reset of the fixture if the yoke’s magnetic-indexing circuit malfunctions (sensor failed or magnet missing) or the stepping-motor is defective ( or its driving IC on the main PCB). The PAN- movement is not located in the default position after the reset.

### **Tilt Er**

(TILT-head movement error) This message will appear after the reset of the fixture if the head’s magnetic-indexing circuit malfunctions (sensor failed or magnet missing) or the stepping-motor is defective (or its driving IC on the main PCB). The TILT- movement is not

located in the default position after the reset.

### **Cyan Color Er**

(Cyan Color-wheel error) This message will appear after the reset of the fixture if the magnetic-indexing circuit malfunctions (sensor failed or magnet missing) or the stepping-motor is defective (or its drive circuit on the main PCB). The Cyan Color wheel is not located in the default position after the reset.

### **Magenta Color Er**

(Magenta Color-wheel error ) This message will appear after the reset of the fixture if the magnetic-indexing circuit malfunctions (sensor failed or magnet missing) or the stepping-motor is defective (or its drive circuit on the main PCB). The Magenta Color-wheel is not located in the default position after the reset.

### **Yellow Color Er**

(Yellow Color-wheel error) This message will appear after the reset of the fixture and if the magnetic-indexing circuit malfunctions (sensor failed or magnet missing) or the stepping-motor is defective (or its driver circuit on the main PCB). The Yellow Color -wheel is not located in the default position after the reset.

### **Color Er**

(Color wheel- error) This message will appear after the reset of the fixture if the yoke's magnetic-indexing circuit malfunction (sensor failed or magnet missing) or the stepping-motor is defective ( or its driving IC on the main PCB). The color wheel is not located in the default position after the reset.

### **Rotation gobo Er**

(Rotating gobo wheel 1- error) This message will appear after the reset of the fixture if the yoke's magnetic-indexing circuit malfunction (sensor failed or magnet missing) or the stepping-motor is defective ( or its driving IC on the main PCB). The Rotating gobo wheel 1 is not located in the default position after the reset.

**Gobo Rotation Er**

(Gobo Rotation wheel 1- error) This message will appear after the reset of the fixture if the yoke's magnetic-indexing circuit malfunction (sensor failed or magnet missing) or the stepping-motor is defective ( or its driving IC on the main PCB). The Gobo Rotation wheel 1 is not located in the default position after the reset.

**Rotation gobo Er**

(Rotating gobo wheel 2- error) This message will appear after the reset of the fixture if the yoke's magnetic-indexing circuit malfunction (sensor failed or magnet missing) or the stepping-motor is defective ( or its driving IC on the main PCB). The Rotating gobo wheel 2 is not located in the default position after the reset.

**Gobo Rotation Er**

(Gobo Rotation wheel 2- error) This message will appear after the reset of the fixture if the yoke's magnetic-indexing circuit malfunction (sensor failed or magnet missing) or the stepping-motor is defective ( or its driving IC on the main PCB). The Gobo Rotation wheel 2 is not located in the default position after the reset.

**Prism Rotation Er**

(Prism Rotation-wheel error) This message will appear after the reset of the fixture if the yoke's magnetic-indexing circuit malfunction (sensor failed or magnet missing) or the stepping-motor is defective ( or its driving IC on the main PCB). The Prism Rotation -wheel is not located in the default position after the reset.

**Shutter, Strobe Er**

(Shutter, Strobe-wheel error) This message will appear after the reset of the fixture if the yoke's magnetic-indexing circuit malfunction (sensor failed or magnet missing) or the stepping-motor is defective (or its driving IC on the main PCB). The Shutter, Strobe -wheel is not located in the default position after the reset.

**Focus Er**

(Focus error) This message will appear after the reset of the fixture if the yoke's

---

magnetic-indexing circuit malfunction (sensor failed or magnet missing) or the stepping-motor is defective (or its driving IC on the main PCB). The Focus is not located in the default position after the reset.

**Zoom Er**

(Zoom motor error) This message will appear after the reset of the fixture if the yoke's magnetic-indexing circuit malfunction (sensor failed or magnet missing) or the stepping-motor is defective (or its driving IC on the main PCB). The Stepless Zoom is not located in the default position after the reset.

**Iris Er**

(Iris error) This message will appear after the reset of the fixture if the yoke's magnetic-indexing circuit malfunction (sensor failed or magnet missing) or the stepping-motor is defective ( or its driving IC on the main PCB). The Iris is not located in the default position after the reset.

**Fire Wheel Er**

(Fire wheel error) This message will appear after the reset of the fixture if the yoke's magnetic-indexing circuit malfunction (sensor failed or magnet missing) or the stepping-motor is defective (or its driving IC on the main PCB). The Fire wheel is not located in the default position after the reset.

## 12. CLEANING AND MAINTENANCE

The following points have to be considered during the inspection:

1. Be sure all screws and fasteners are securely tightened at all times. Loose screws may fall out during normal operation resulting in damage or injury as larger parts could fall.
2. There must not be any deformations on the housing, color lenses, rigging hardware and rigging points (ceiling, suspension, trussing). Deformations in the housing could allow for UV radiation leakage. Damaged rigging points or unsecured rigging could cause the unit to fall and seriously injure a person.
3. All mechanical parts and motors should not show any traces of serious wear and should rotate freely.
4. Electric power supply cables must not show any damage, material fatigue or sediments. Never remove the ground prong from the power cable.

*Further instructions depending on installation and usage have to be adhered to by a skilled installer and any safety problems should be addressed before attempting operation.*



### CAUTION!

Disconnect from mains before starting maintenance operation.

We recommend frequent cleaning of the device, this will ensure operational longevity and crisp light output. When cleaning, please use a moist, lint-free cloth. Never use alcohol or solvents.

There are no user serviceable parts inside this fixture with the exception of the lamp. Please refer all other service related issues to an authorized Elation service technician.

Should you decide to service the fixture yourself please order genuine Elation parts directly from Elation.

### 13. 2-YEAR LIMITED WARRANTY

A. Elation Professional® hereby warrants, to the original purchaser, Elation Professional® products to be free of manufacturing defects in material and workmanship for a period of two years, (730 days) from the date of purchase. This warranty shall be valid only if the product is purchased within the United States of America, including possessions and territories. It is the owner's responsibility to establish the date and place of purchase by acceptable evidence, at the time service is sought.

B. For warranty service, send the product only to the Elation Professional® factory. All shipping charges must be pre-paid. If the requested repairs or service (including parts replacement) are within the terms of this warranty, Elation Professional® will pay return shipping charges only to a designated point within the United States. If the entire instrument is sent, it must be shipped in its original package. No accessories should be shipped with the product. If any accessories are shipped with the product, Elation Professional® shall have no liability what so ever for loss of or damage to any such accessories, nor for the safe return thereof.

C. This warranty is void if the serial number has been altered or removed; if the product is modified in any manner which Elation Professional® concludes, after inspection, affects the reliability of the product; if the product has been repaired or serviced by anyone other than the Elation Professional® factory unless prior written authorization was issued to purchaser by Elation Professional®; if the product is damaged because not properly maintained as set forth in the instruction manual.

D. This is not a service contract, and this warranty does not include maintenance, cleaning or periodic check-up. During the period specified above, Elation Professional® will replace defective parts at its expense, and will absorb all expenses for warranty service and repair labor by reason of defects in material or workmanship. The sole responsibility of Elation Professional® under this warranty shall be limited to the repair of the product, or replacement thereof, including parts, at the sole discretion of Elation Professional®. All products covered by this warranty were manufactured after January 1, 1990, and bare identifying marks to that

effect.

E. Elation Professional® reserves the right to make changes in design and/or improvements upon its products without any obligation to include these changes in any products theretofore manufactured.

F. No warranty, whether expressed or implied, is given or made with respect to any accessory supplied with products described above. Except to the extent prohibited by applicable law, all implied warranties made by Elation Professional® in connection with this product, including warranties of merchantability or fitness, are limited in duration to the warranty period set forth above. And no warranties, whether expressed or implied, including warranties of merchantability or fitness, shall apply to this product after said period has expired. The consumer's and or Dealer's sole remedy shall be such repair or replacement as is expressly provided above; and under no circumstances shall Elation Professional® be liable for any loss or damage, direct or consequential, arising out of the use of, or inability to use, this product.

G. This warranty is the only written warranty applicable to Elation Professional® Products and supersedes all prior warranties and written descriptions of warranty terms and conditions heretofore published.



## 14. Photometric Data:

Beam Angle 15°

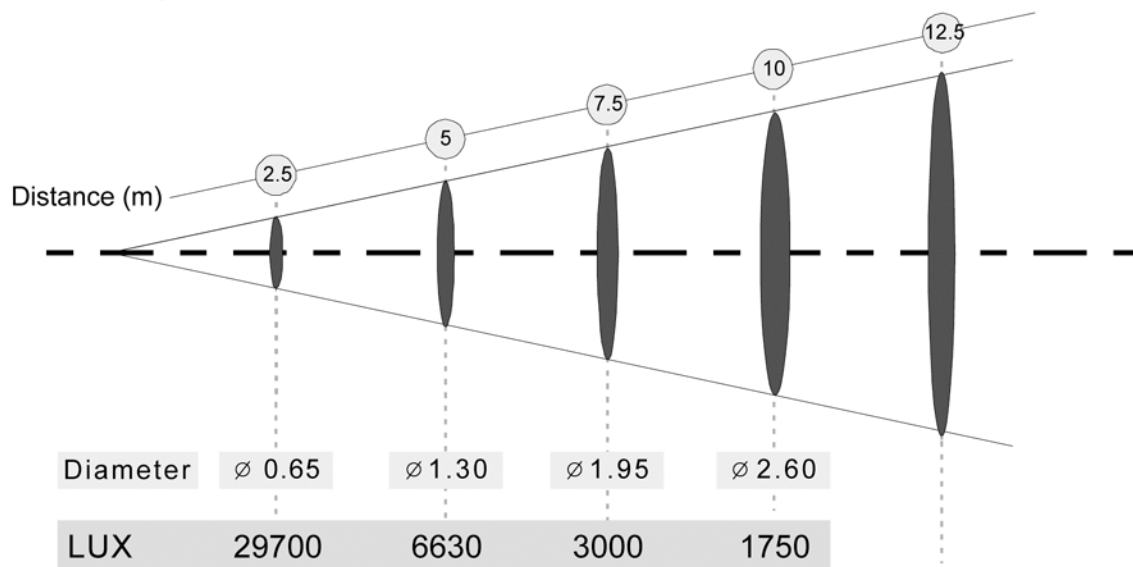

Beam Angle 30°

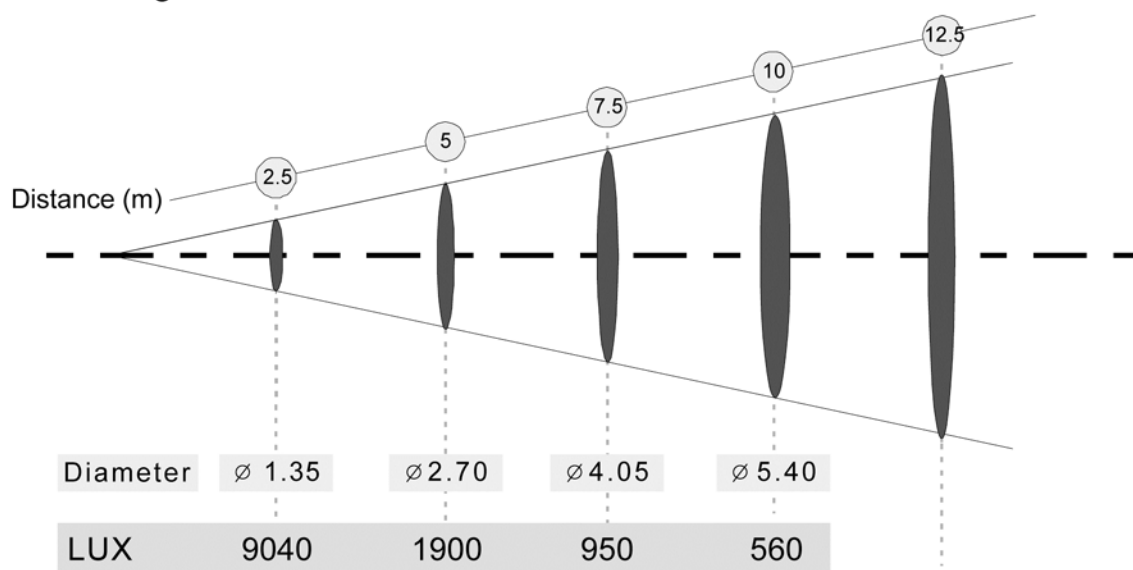

## 15. Gobos:

Gobo Wheel 1 - Rotating



Gobo Wheel 2 - Fixed



## 16. Dimensional Drawings:

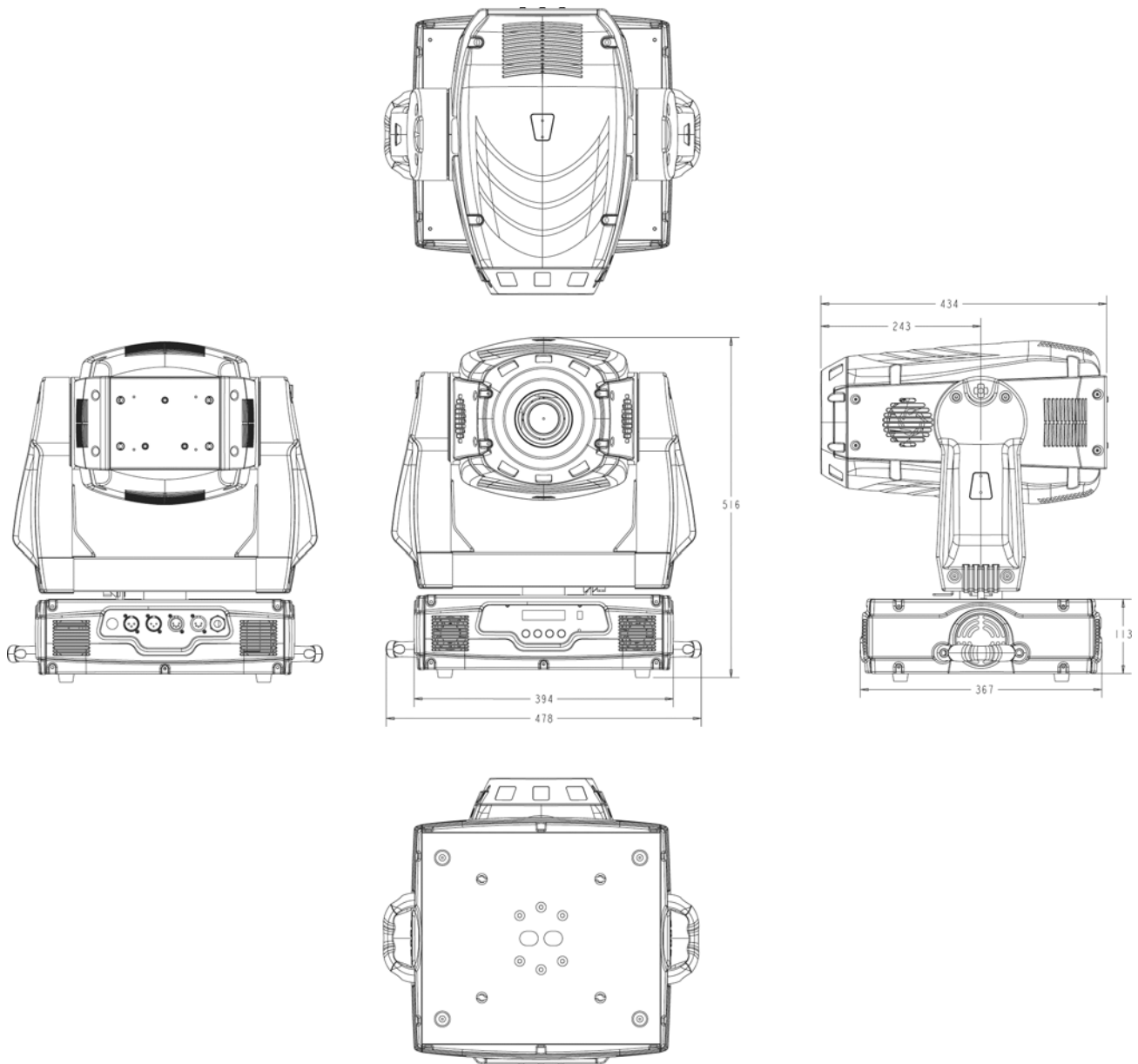

# 17. Circuit Schematic

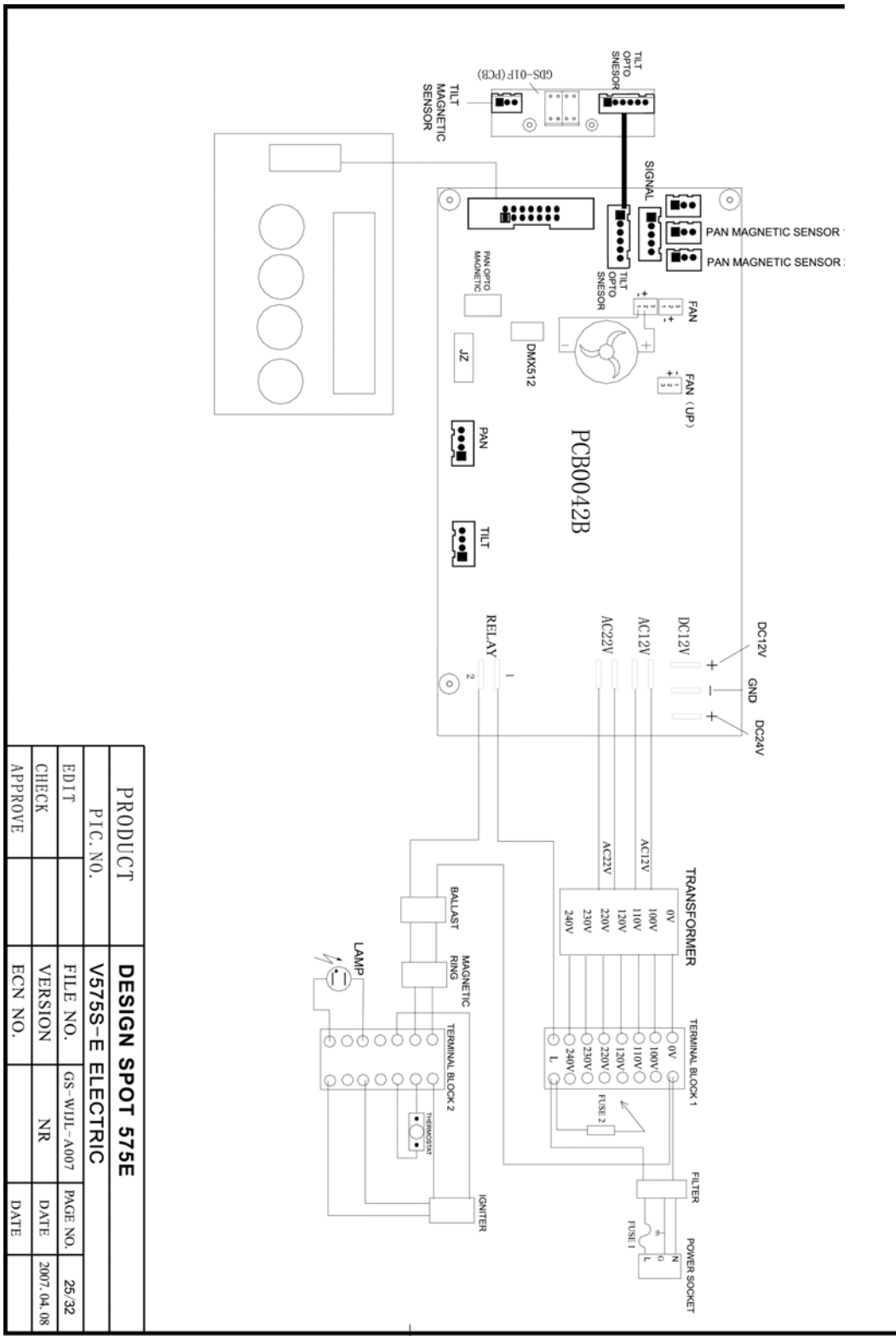

<b>PRODUCT</b>		<b>DESIGN SPOT 575E</b>	
PIC. NO.		FILE NO.	GS-WJL-A007
EDIT		VERSION	NR
CHECK		ECN NO.	
APPROVE			
		PAGE NO.	25/32
		DATE	2007.04.08

## 18. TECHNICAL SPECIFICATIONS

<b>Power supply</b>	
<b>Power consumption</b>	90 ~ 260V, 50 ~ 60 Hz 800 Watt, 4.5 A, electronic ballast, (blind current compensated)
<b>Fuse protection</b>	120V = 10A/250V, GMA (5x20mm fine-wire fuse) 220V = 5A/250V, GMA (5x20mm fine-wire fuse)
<b>Lamp</b>	
<b>Type</b>	Philips Gold MSR575/2 SA DE
<b>Life time</b>	750 Hrs
<b>Color temperature</b>	7200° K
<b>Luminous flux</b>	43.000 lm
<b>Optical system</b>	
Parabolic dichroic glass reflector	
Variable beam angle 14° ~ 28°	
Lenses hardened and tempered, anti-reflex coated	
<b>Colors</b>	
8 dichroic filter plus white, half-color compatible	
<b>Gobos</b>	
Gobo-wheel 1: 7 interchangeable rotating gobos plus "open", 4 glass Gobos	
Gobo-wheel 2: 7 interchangeable rotating gobos plus "open"	
Gobo outside diameter 26.9 mm, image size 23 mm	
Gobo thickness: glass = 1 mm, steel = 0.15 mm	
<b>CMY Color mixing unit</b>	
Cyan color filter 0 - 100%	
Magenta color filter 0 - 100%	
Yellow color filter 0 - 100%	
<b>Prism</b>	
Rotating 3-face prism, rotating and variable in speed	
<b>Shutter / Strobe / Dimmer</b>	
Strobe effect with variable speed 1 - 10 flashes per second	
Continuously mechanical dimmer 0 - 100%	
<b>Iris</b>	
Motor driven iris from open to close, variable speed, pulse effect	
<b>Focus</b>	
Motor driven focus from near to far away	
<b>Zoom</b>	
Zoom range 14° - 32°	
<b>Effect wheel</b>	
Rotating and indexed Effect wheel, different patterns, exchangeable	
<b>DMX Channels</b>	

24 (16bit – default) **or** 22 (8bit – user selectable)

**Drive**

Standard DMX-512, 3 pole XLR; [+] = Pin 3 [-] = Pin 2 [Ground] = Pin 1 or 5 pole XLR; n/a = Pin 5, n/a = Pin 4, [+] = Pin 3, [-] = Pin 2, [Ground] = Pin 1  
Starting DMX [001].

**Pan / Tilt**

**Pan - movement** 630° in max. 2.0 seconds, 16 bit resolution

**Tilt - movement** 265° in max. 1.5 seconds, 16 bit resolution

**Weights and measures**

**Width of the base** 61cm (W) x 46cm (L) x 51cm (H) ~ Head vertical

**Length of the base** 32.5Kgs / 72Lbs

**Height (head vertical)**

**Weight (net)** 32.5Kgs / 72Lbs

*Please Note: Specifications and improvements in the design of this unit and this manual are subject to change without any prior written notice.*

Elation Professional  
4295 Charter Street  
Los Angeles, CA. 90058  
323-582-3322 / 323-582-3108 fax  
www.ElationLighting.com /  
Info@ElationLightng.com