

# ARENA Q7 ZOOM™

user manual

©2015 **ELATION PROFESSIONAL** all rights reserved. Information, specifications, diagrams, images, and instructions herein are subject to change without notice. ELATION PROFESSIONAL logo and identifying product names and numbers herein are trademarks of ELATION PROFESSIONAL. Copyright protection claimed includes all forms and matters of copyrightable materials and information now allowed by statutory or judicial law or hereinafter granted. Product names used in this document may be trademarks or registered trademarks of their respective companies and are hereby acknowledged. All non-ELATION brands and product names are trademarks or registered trademarks of their respective companies.

**ELATION PROFESSIONAL** and all affiliated companies hereby disclaim any and all liabilities for property, equipment, building, and electrical damages, injuries to any persons, and direct or indirect economic loss associated with the use or reliance of any information contained within this document, and/or as a result of the improper, unsafe, insufficient and negligent assembly, installation, rigging, and operation of this product.

**Elation Professional USA** | 6122 S. Eastern Ave. | Los Angeles, CA. 90040  
323-582-3322 | 323-832-9142 fax | [www.elationlighting.com](http://www.elationlighting.com) |

**Elation Professional B.V.** | Junostraat 2 | 6468 EW Kerkrade, Netherlands  
+31 45 546 85 66 | +31 45 546 85 96 fax | [www.elationlighting.eu](http://www.elationlighting.eu) |

## DOCUMENT VERSION



Please check [www.elationlighting.com](http://www.elationlighting.com) for the latest revision/update of this manual.

Date	Document Version	Software Version	DMX Channel Modes	Notes
2/2015	1	A: ≥1.1 Ab: ≥1.0 B: ≥1.1 Bb: ≥1.0	7 / 9 / 15	Updated manual format.

## CONTENTS

General Information	4
Warranty	6
Safety Instructions	7
General Guidelines	8
Fixture Overview	9
Fixture Installation	10
Understanding DMX	13
Fixture Menu	17
DMX Channel Functions And Values	19
Cleaning and Maintenance	21
Technical Specifications	22
Optional Accessories	24

## GENERAL INFORMATION

### INTRODUCTION

Congratulations, you have just purchased one of the most innovative and revolutionary new hybrid lighting fixtures on the market today! The **ARENA Q7 ZOOM™** has been designed to perform reliably for years when the guidelines in this booklet are followed. Please read and understand the instructions in this manual carefully and thoroughly before attempting to operate this unit. These instructions contain important information regarding safety during use and maintenance.

### UNPACKING

Thank you for purchasing the **ARENA Q7 ZOOM™** by Elation Professional®. Every **ARENA Q7 ZOOM™** has been thoroughly tested and has been shipped in perfect operating condition. Carefully check the shipping carton for damage that may have occurred during shipping. If the carton appears to be damaged, carefully inspect your unit for damage and be sure all accessories necessary to operate the unit have arrived intact. In the event damage has been found or parts are missing, please contact our customer support team for further instructions. Please do not return this unit to your dealer without first contacting customer support at the number listed below. Please do not discard the shipping carton in the trash. Please recycle whenever possible.

### BOX CONTENTS

- (1) Power Cable
- Manual & Warranty Card

## CUSTOMER SUPPORT

Elation Professional® provides a customer support line, to provide set up help and to answer any question should you encounter problems during your set up or initial operation. You may also visit us on the web at [www.elationlighting.com](http://www.elationlighting.com) for any comments or suggestions. For service related issue please contact Elation Professional®.

### **ELATION SERVICE USA - Monday - Friday 8:00am to 5:00pm PST**

**Voice: 323-582-3322**

**Fax: 323-832-9142**

E-mail: [support@elationlighting.com](mailto:support@elationlighting.com)

### **ELATION SERVICE EUROPE - Monday - Friday 08:30 to 17:00 CET**

**Voice: +31 45 546 85 30**

**Fax: +31 45 546 85 96**

E-mail: [support@elationlighting.eu](mailto:support@elationlighting.eu)

## WARRANTY REGISTRATION

Please fill out the enclosed warranty card to validate your purchase. All returned service items whether under warranty or not, must be freight pre-paid and accompany a return authorization (R.A.) number. The R.A. number must be clearly written on the outside of the return package. A brief description of the problem as well as the R.A. number must also be written down on a piece of paper and included in the shipping container. If the unit is under warranty, you must provide a copy of your proof of purchase invoice. Items returned without a R.A. number clearly marked on the outside of the package will be refused and returned at customer's expense. You may obtain a R.A. number by contacting customer support at 323-582-3322.



## **IMPORTANT NOTICE!**

**There are no user serviceable parts inside this unit. Do not attempt any repairs yourself; doing so will void your manufactures warranty. Damages resulting from modifications to this fixture and/or the disregard of safety and general user instructions found in this user manual void the manufactures warranty and are not subject to any warranty claims and/or repairs.**

## LIMITED WARRANTY

A. Elation Professional® hereby warrants, to the original purchaser, Elation Professional® products to be free of manufacturing defects in material and workmanship for a period of two years (730 days), and Elation Professional® product rechargeable batteries to be free of manufacturing defects in material and workmanship for a period of six months (180 days), from the original date of purchase. This warranty excludes discharge lamps and all product accessories. This warranty shall be valid only if the product is purchased within the United States of America, including possessions and territories. It is the owner's responsibility to establish the date and place of purchase by acceptable evidence, at the time service is sought.

B. For warranty service, send the product only to the Elation Professional® factory. All shipping charges must be pre-paid. If the requested repairs or service (including parts replacement) are within the terms of this warranty, Elation Professional® will pay return shipping charges only to a designated point within the United States. If any product is sent, it must be shipped in its original package and packaging material. No accessories should be shipped with the product. If any accessories are shipped with the product, Elation Professional® shall have no liability what so ever for loss and/or or damage to any such accessories, nor for the safe return thereof.

C. This warranty is void if the product serial number and/or labels are altered or removed; if the product is modified in any manner which Elation Professional® concludes, after inspection, affects the reliability of the product; if the product has been repaired or serviced by anyone other than the Elation Professional® factory unless prior written authorization was issued to purchaser by Elation Professional®; if the product is damaged because not properly maintained as set forth in the product instructions, guidelines and/or user manual.

D. This is not a service contract, and this warranty does not include any maintenance, cleaning or periodic check-up. During the periods as specified above, Elation Professional® will replace defective parts at its expense, and will absorb all expenses for warranty service and repair labor by reason of defects in material or workmanship. The sole responsibility of Elation Professional® under this warranty shall be limited to the repair of the product, or replacement thereof, including parts, at the sole discretion of Elation Professional®. All products covered by this warranty were manufactured after January 1, 1990, and bare identifying marks to that effect.

E. Elation Professional® reserves the right to make changes in design and/or performance improvements upon its products without any obligation to include these changes in any products theretofore manufactured.

F. No warranty, whether expressed or implied, is given or made with respect to any accessory supplied with the products described above. Except to the extent prohibited by applicable law, all implied warranties made by Elation Professional® in connection with this product, including warranties of merchantability or fitness, are limited in duration to the warranty periods set forth above. And no warranties, whether expressed or implied, including warranties of merchantability or fitness, shall apply to this product after said periods have expired. The consumer's and/or dealer's sole remedy shall be such repair or replacement as is expressly provided above; and under no circumstances shall Elation Professional® be liable for any loss and/or damage, direct and/or consequential, arising out of the use of, and/or the inability to use, this product.

G. This warranty is the only written warranty applicable to Elation Professional® products and supersedes all prior warranties and written descriptions of warranty terms and conditions heretofore published.

## SAFETY INSTRUCTIONS



The **ARENA Q7 ZOOM™** is an extremely sophisticated piece of electronic equipment. To guarantee a smooth operation, it is important to follow the guidelines in this manual. The manufacturer of this device will not accept responsibility for damages resulting from the misuse of this fixture due to the disregard of the information printed in this manual.



This device falls under **PROTECTION CLASS 1**. It's essential this device be grounded properly. Only qualified personnel should perform all electrical connections.

### C A U T I O N S



**KEEP THIS FIXTURE AWAY FROM RAIN AND MOISTURE!**



**UNPLUG POWER BEFORE SERVICING FIXTURE!**



**NEVER TOUCH FIXTURE DURING OPERATION, IT MAY BE HOT!**



**NEVER LOOK DIRECTLY INTO THE LIGHT SOURCE!  
SENSITIVE PERSONS MAY SUFFER AN EPILEPTIC SHOCK!**

- For proper operation, follow the **Installation** guidelines described in this manual. Only qualified and certified personnel should perform installation of this fixture and only the original rigging parts (brackets) included with this fixture should be used for installation. Any modifications will void the original manufacturer's warranty and increase the risk of damage and/or personal injury.
- Never look directly into the light source of this fixture to prevent risk of injury to your retina, which may induce blindness. Those suffering from **EPILEPSY** should avoid looking directly into the light source of this unit at all times.
- The fan and air inlets must remain clean and never blocked. Allow approx. 6" (15cm) between this fixture and other devices or a wall for proper cooling.
- Always disconnect from main power source before performing any type of service and/or cleaning procedure. Only handle the power cord by the plug end, never pull out the plug by tugging the wire portion of the cord.
- Do not operate this fixture if the power cord has become frayed, crimped and/or damaged. If the power cord is damaged, replace it immediately with a new one of similar power rating.

## GENERAL GUIDELINES

- **NEVER OPEN THIS FIXTURE WHILE IN USE!**
- During the initial operation of this fixture, a light smoke or smell may emit from the interior of the fixture. This is a normal process and is caused by excess paint in the interior of the casing burning off from the heat associated with the lamp and will decrease gradually over time.
- This fixture is a professional lighting effect designed for **INDOOR / DRY LOCATIONS ONLY** on stage, in nightclubs, theatres, etc.
- Please make sure there are **NO FLAMMABLE MATERIALS** close to the fixture while operating, to prevent any fire hazard.
- **Minimum** distance of inflammable materials from the surface **1.6 feet (0.5m)**.
- **Maximum** temp of the external surface **185°F (85°C)**.
- The fixture must be installed in a location with adequate ventilation, at least **0.6" (15cm)** from adjacent surfaces. Be sure no air ventilation slots are blocked.
- **DO NOT** attempt installation and/or operation without knowledge how to do so.
- **DO NOT** allow operation by persons who are not qualified to operate this type of fixture. Most damages are the result of operations by nonprofessionals.
- Consistent operational breaks may ensure the fixture will function properly for many years to come.
- **DO NOT** shake fixture, avoid brute force when installing and/or operating fixture.
- Always install the fixture with an appropriate safety cable. When installing the fixture in a suspended environment, always use mounting hardware that is no less than M10 x 25 mm, also be sure the hardware is insert in the pre-arranged screw holes in the bracket of the fixture.
- Use the original packaging and materials to transport the fixture in for service.
- **DO NOT TOUCH** the housing bare-hand during its operation. Turn OFF the power and allow approximately 15 minutes for the fixture to cool down before replacing or serving.



## FIXTURE OVERVIEW

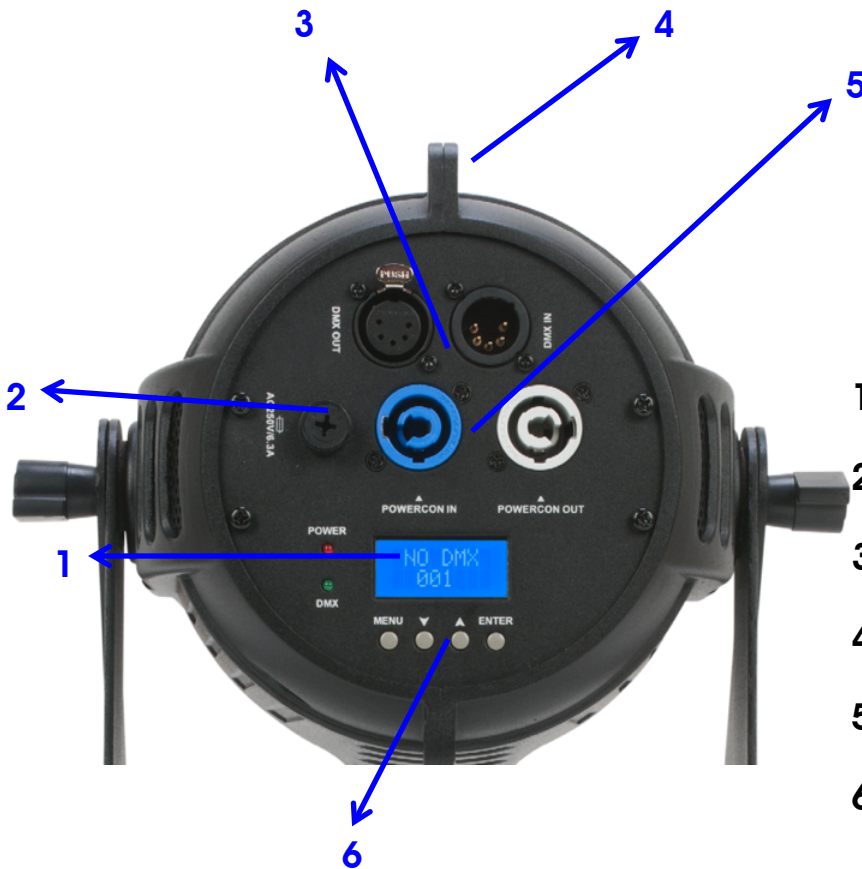

1. LCD Menu Function Display
2. FUSE
3. 5pin DMX IN/OUT
4. Safety Cable Attachment Points
5. Power Cable In/Out
6. MENU, DOWN, UP, ENTER Buttons

## FIXTURE INSTALLATION



### FLAMMABLE MATERIAL WARNING

Keep fixture at least 5.0 ft. (1.5m) away from any flammable materials, decorations, pyrotechnics, etc.



### ELECTRICAL CONNECTIONS

A qualified electrician should be used for all electrical connections and/or installations.

## CAUTIONS

- For added protection, mount the fixture in areas outside walking paths, seating areas, or in areas where unauthorized personnel might reach the fixture.
- Maximum ambient operating temperature for this fixture is **104°F. (40°C)**  
Do not use the fixture under or above this temperature.
- Maximum temperature of the external surface **185°F (85°C)**.
- Before mounting the fixture to any surface, make sure the installation area can hold a minimum point load of **10 times** the weight of the fixture. **(132 lbs / 60 kg)**
- Fixture installation must always be secured with a secondary safety attachment, such as an appropriate safety cable.
- Never stand directly below the device when mounting, removing or servicing.

## POWER LINKING

Max number of units that can be power linked is **15 units @120V / 28 units @230V**.



### W A R N I N G

**MINIMUM** distance of inflammable materials from surface 1.6 feet (0.5m)  
Keep fixture at least 5.0 feet (1.5m) away from any flammable materials, decorations, pyrotechnics, etc.

## MOUNTING POINTS

- Overhead mounting requires extensive experience, including amongst others calculating working load limits, installation material being used, and periodic safety inspection of all installation material and the device. If you lack these qualifications, do not attempt the installation yourself. Improper installation can result in bodily injury.
- Fixture is fully operational in the specific mounting positions as illustrated below.

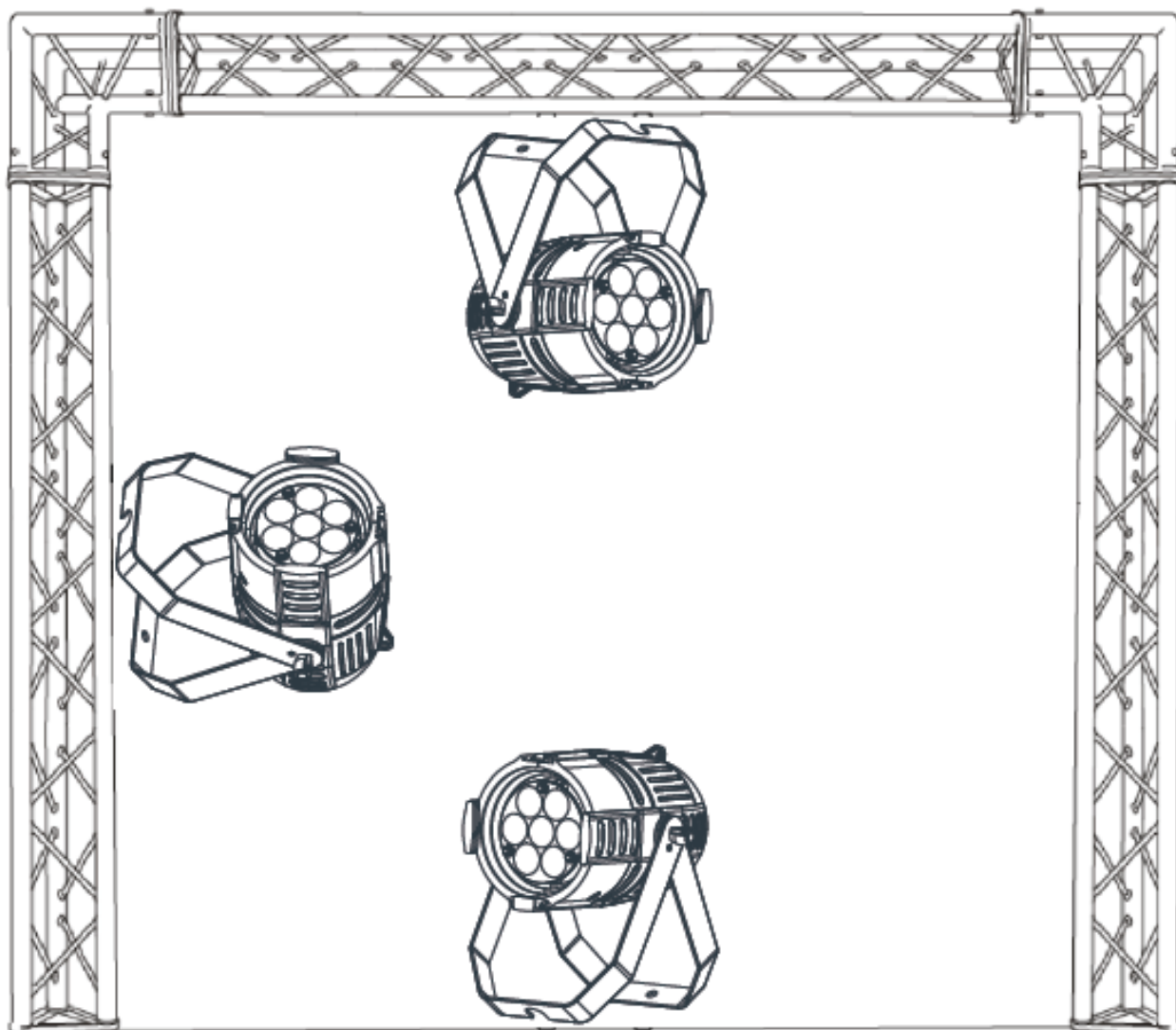

## SAFETY CABLE

**Always use a Safety Cable whenever installing this fixture in a suspended environment to ensure the fixture will not drop if the clamp fails.**

## CLAMP MOUNTING

The **ARENA Q7 ZOOM™** includes an adjustable mounting yoke that attaches to both sides of the fixture. When mounting this fixture to truss be sure to secure an appropriately rated clamp to the mounting yoke using a M10 screw fitted through the center hole of the mounting yoke. Be sure to attach a **Safety Cable** to the fixture using the safety cable rigging point on the back of the fixture as illustrated below.

## SECURING

Regardless of the rigging option you choose for your **ARENA Q7 ZOOM™** always be sure to secure your fixture with a safety cable. The fixture provides a built-in rigging point for a safety cable on the back of the fixture as illustrated below. Be sure to only use the designated rigging point for the safety cable.

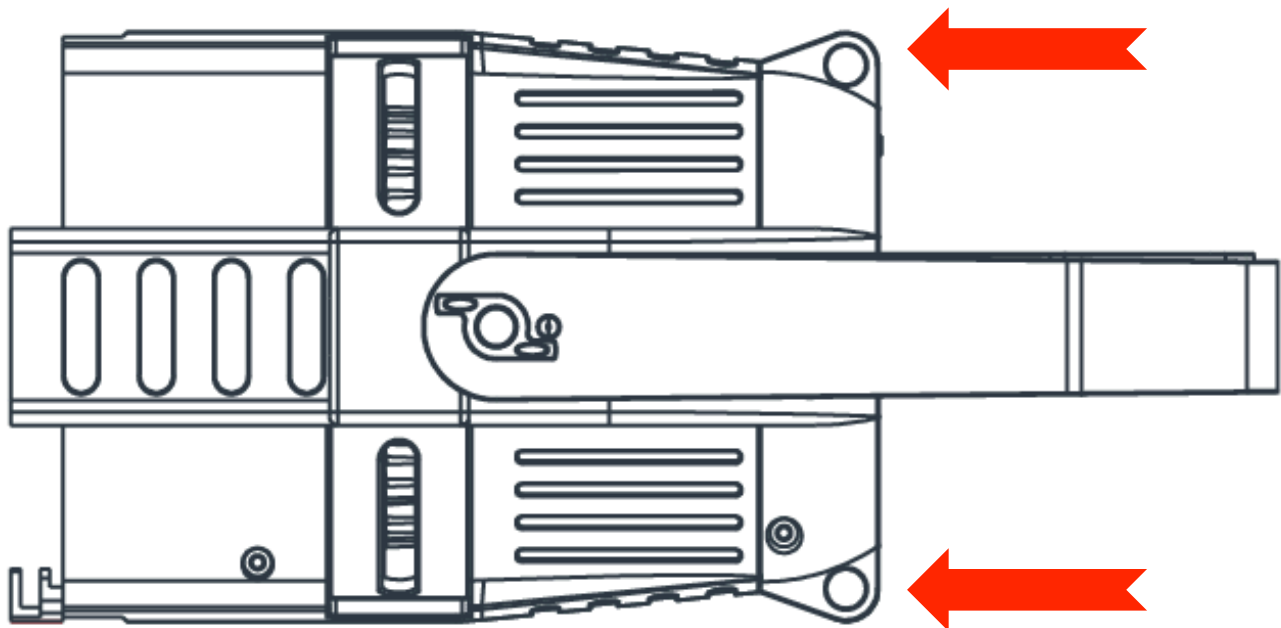

## UNDERSTANDING DMX

### DMX-512

DMX is short for Digital Multiplex. This is a universal protocol used by most lighting and controller manufactures as a form of communication between intelligent fixtures and controllers. DMX allows all makes and models of different manufactures to be linked together and operate from a single controller. This is possible as long as all the fixtures and the controller are DMX compliant. A DMX controller sends the DMX data instructions to the fixture allowing the user to control the different aspects of an intelligent light. DMX data is sent out as serial data that travels from fixture to fixture via data "IN" and data "OUT" XLR terminals located on the fixtures (most controllers will only have output jacks).

### DMX LINKING

To ensure proper DMX data transmission, always use proper DMX cables and a terminator. When using several DMX fixtures try to use the shortest cable path possible. Never split a DMX line with a "Y" style connector. The order in which the fixtures are connected in a DMX line does not influence the DMX addressing. For example; a fixture assigned a starting DMX address of 1 may be placed anywhere in the DMX chain, at the beginning, at the end, or anywhere in the middle. The DMX controller knows to send data assigned to address 1 to that fixture no matter where it is located in the DMX chain. The **ARENA Q7 ZOOM™** can be controlled via DMX-512 protocol and the DMX address is set via the control menu.

### DATA CABLE (DMX Cable) REQUIREMENTS (For DMX and Master/Slave Operation)

Your fixture and your DMX controller require a standard 3pin or 5pin XLR connector for data input and data output (see figure below). If you are making your own cables, be sure to use two conductor, shielded digital DMX cable rated at 120 ohms; this cable is designed for DMX transmission and may be purchased from your Elation dealer or at most professional lighting retailers. Your cables should be made with a male and female XLR connector on either end of the cable. Also, remember that a DMX line must be daisy chained and cannot be split, unless using an approved DMX splitter such as **Elation's Opto Branch 4™, Opto Branch 8™, or DMX-Branch/4™**.

DMX Output  
3-Pin XLR Socket



DMX Input  
3-Pin XLR Socket



1: Ground  
2: Data (-)  
3: Data (+)

DMX Output  
5-Pin XLR Socket



DMX Input  
5-Pin XLR Socket



1: Ground  
2: Data (-)  
3: Data (+)  
4: Open  
5: Open



Be sure to follow the above figure when making your own cables. Do not use the ground lug on the XLR connector. Do not connect the cable's shield conductor to the ground lug or allow the shield conductor to come in contact with the XLR outer casing. Grounding the shield could cause a short circuit and erratic behavior.

### DMX-512 CONTROLLER CONNECTION

Connect the provided XLR cable to the female XLR output of your controller and the other side to the male XLR input of the **ARENA Q7 ZOOM™**. The diagram below illustrates a typical DMX-512 connection when the fixture is in the **15 Channel Mode**. You can chain multiple panels together through serial linking. The cable that should be used is two conductor, shielded DMX cable with XLR input and output connectors. Always be sure daisy chain your in and out data connections, never split or "Y" your DMX connections unless you are using an approved DMX splitter such as **Elation's Opto Branch 4™, Opto Branch 8™, or DMX-Branch/4™**.

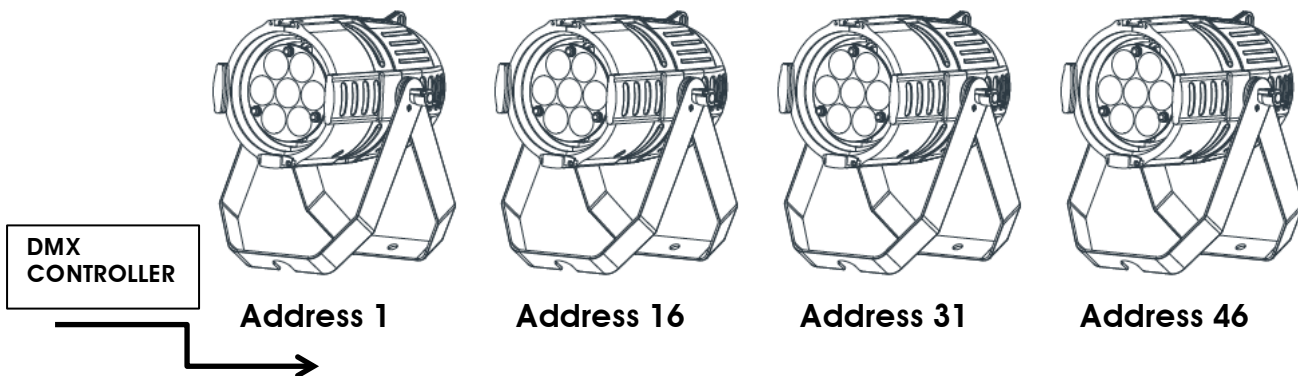

### DMX-512 CONNECTION WITH DMX TERMINATOR

A DMX terminator should be used in all DMX lines especially in longer runs. The use of a terminator may avoid erratic behavior in your DMX line. A terminator is a 120 ohm 1/4 watt resistor that is connected between pins 2 and 3 of a male XLR connector (DATA + and DATA -). This fixture is inserted in the female XLR connector of the last fixture in your daisy chain to terminate the line. Using a line terminator will decrease the possibilities of erratic behavior.

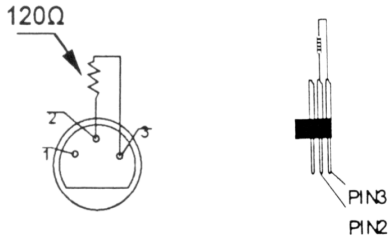

Termination reduces signal errors and avoids signal transmission problems and interference. It is always advisable to connect a DMX terminal, (Resistance 120 Ohm 1/4 W) between PIN 2 (DMX-) and PIN 3 (DMX +) of the last fixture.

### 5pin XLR DMX CONNECTORS

Some manufactures use 5pin XLR connectors for DATA transmission in place of 3pin. 5pin XLR fixtures may be implemented in a 3pin XLR DMX line. When inserting standard 5pin XLR connectors in to a 3pin line a cable adaptor must be used, these adaptors are readily available at most electric stores. The following chart details a proper cable conversion.

3-Pin XLR to 5-Pin XLR Conversion		
Conductor	3-Pin XLR Female (Out)	5-Pin XLR Male (In)
Ground/Shield	Pin 1	Pin 1
Data Compliment (- signal)	Pin 2	Pin 2
Data True (+ signal)	Pin 3	Pin 3
Not Used		Pin 4 - Do Not Use
Not Used		Pin 5 - Do Not Use

## DMX ADDRESSING

All fixtures should be given a DMX starting address when using a DMX controller, so the correct fixture responds to the correct control signal. This digital starting address is the channel number from which the fixture starts to “listen” to the digital control information sent out from the DMX controller. The allocation of this starting DMX address is achieved by setting the correct DMX address on the digital display located on the back of the fixture.

You can set the same starting address for all fixtures or a group of fixtures, or set different address for each individual fixture. Be advised that setting all fixtures to the same DMX address will subsequently control all fixtures in the same fashion, in other words, changing the settings of one channel will affect all the fixtures simultaneously.

If you set each fixture to a different DMX address, each unit will start to “listen” to the channel number you have set, based on the quantity of control channels (DMX channels) of each fixture. That means changing the settings of one channel will only affect the selected fixture.

In the case of the **ARENA Q7 ZOOM™**, when in the **15 Channel Mode** you should set the starting DMX address of the first unit to 1, the second unit to 16 (1 + 15), the third unit to 31 (16 + 15), the fourth unit to 46 (31 + 15), and so on.

**Note:** During start-up the **ARENA Q7 ZOOM™** will automatically detect whether a DMX data signal is being received or not. If your fixture is connected to a DMX controller and it is not receiving a DMX signal, please check the following:

- The 5pin XLR input plug (cable with DMX signal from controller) is not connected or is not inserted completely into the DMX input jack of the fixture.
- The DMX controller is switched off or defective.
- The DMX cable or connector is defective.
- A DMX terminator has been inserted into the last fixture in your DMX chain.



# FIXTURE MENU

## ON-BOARD SYSTEM MENU

The **ARENA Q7 ZOOM™** comes with an easy to navigate system menu. The next section will detail the functions of each command in the system menu.

## LCD MENU CONTROL PANEL

The control panel (see image below) located on back of the fixture allows you to access the main menu and make all necessary adjustments to the **ARENA Q7 ZOOM™**. During normal operation, pressing **MENU** button once will access the fixture's main menu. Once in the main menu you can navigate through the different functions and access the sub-menus with the **UP** and **DOWN** buttons. Once you reach a field that requires adjusting, press the **ENTER** button to activate that field and use the **UP** and **DOWN** buttons to adjust the field. Pressing the **ENTER** button once more will confirm your setting. You may exit the main menu at any time without making any adjustments by pressing and holding the **MENU** button for 3 seconds.

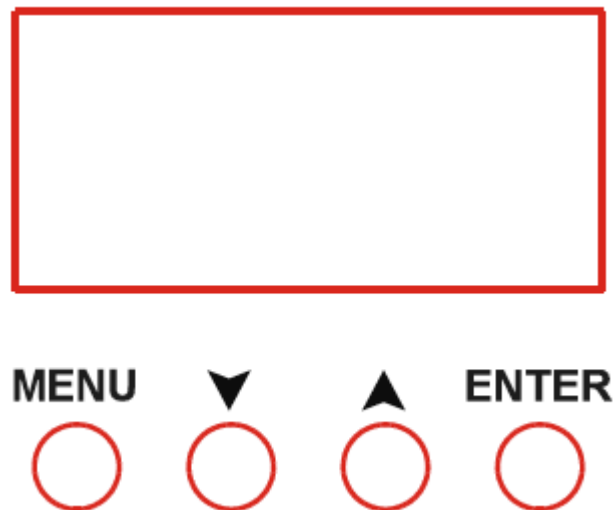

The **MENU** display will lock when **NO** buttons are pressed for **30 seconds**. When the display locks, none of the control panel buttons will respond. To unlock the display, press and hold the **MENU** button **3 seconds** to access the menu options once again.

**ELATION® ARENA Q7 ZOOM™  
MAIN MENU**

Specifications are subject to change without any prior written notice.

MENU	OPTIONS / VALUES		DESCRIPTION
DMX Address	1 - 512		Set DMX Address
Channel Mode	7Chan, 9Chan, 15 Chan		Set DMX Channel Mode
Dimmer Curve	Standard, Theatre, Architec, TV, Stage		Set Dimming Curve
Black Out	Yes, Hold		
Back Light	On, Off		Turn LCD Display Back Light On/Off
White Balance	Red	125 - 255	Set White Balance
	Green	125 - 255	
	Blue	125 - 255	
Manual Color	Red	0 - 255	Set Functions Manually
	Green	0 - 255	
	Blue	0 - 255	
	White	0 - 255	
	Color (Macros)	0 - 255	
	Zoom	0 - 255	
	Dimmer	0 - 255	
	Strobe	0 - 255	
Auto Test			Run Self-Test Using Internal Programs
Temp			Displays Fixture Temperature
Fixture Time			Displays Total Fixture Run Time
Firmware Version			Displays Fixture Software Version
Reset			Reset Fixture

# DMX CHANNEL FUNCTIONS AND VALUES

ELATION® ARENA Q7 ZOOM™				
DMX Channel Values / Functions (15 DMX Channels)				
Specifications subject to change without any prior written notice.				
MODE / CHANNEL			VALUE	FUNCTION
7	9	15		
1	1	1		RED
			0-255	Red ( 0-Black , 255-100% Red )
		2		RED FINE
			0-255	Red FINE Adjustment
2	2	3		GREEN
			0-255	Green ( 0-Black , 255-100% Green )
		4		GREEN FINE
			0-255	Green FINE Adjustment
3	3	5		BLUE
			0-255	Blue ( 0-Black , 255-100% Blue )
		6		BLUE FINE
			0-255	Blue FINE Adjustment
4	4	7		WHITE
			0-255	White ( 0-Black , 255-100% White )
		8		WHITE FINE
			0-255	White FINE Adjustment
	5	9		COLOR MACROS
			0-4	Preset Color 1
			5-8	Preset Color 2
			9-12	Preset Color 3
			13-16	Preset Color 4
			17-20	Preset Color 5
			21-24	Preset Color 6
			25-28	Preset Color 7
			29-32	Preset Color 8
			33-36	Preset Color 9
			37-40	Preset Color 10
			41-44	Preset Color 11
			45-48	Preset Color 12
			49-52	Preset Color 13
			53-56	Preset Color 14
			57-60	Preset Color 15
			61-64	Preset Color 16
			65-68	Preset Color 17
			69-72	Preset Color 18
			73-76	Preset Color 19
			77-80	Preset Color 20
			81-84	Preset Color 21
			85-88	Preset Color 22
			89-92	Preset Color 23
			93-96	Preset Color 24
			97-100	Preset Color 25
			101-104	Preset Color 26
			105-108	Preset Color 27
			109-112	Preset Color 28
			113-116	Preset Color 29
			117-120	Preset Color 30
			121-124	Preset Color 31
			125-128	Preset Color 32
129-132	Preset Color 33			

ELATION® ARENA Q7 ZOOM™			
DMX Channel Values / Functions (15 DMX Channels)			
Specifications subject to change without any prior written notice.			
MODE / CHANNEL			FUNCTION
7	9	15	
			<b>COLOR MACROS - Continued</b>
			133-136 Preset Color 34
			137-140 Preset Color 35
			141-144 Preset Color 36
			145-148 Preset Color 37
			149-152 Preset Color 38
			153-156 Preset Color 39
			157-160 Preset Color 40
			161-164 Preset Color 41
			165-168 Preset Color 42
			169-172 Preset Color 43
			173-176 Preset Color 44
			177-180 Preset Color 45
			181-184 Preset Color 46
			185-188 Preset Color 47
			189-192 Preset Color 48
			193-196 Preset Color 49
			197-200 Preset Color 50
			201-204 Preset Color 51
			205-208 Preset Color 52
			209-212 Preset Color 53
			213-216 Preset Color 54
			217-220 Preset Color 55
			221-224 Preset Color 56
			225-228 Preset Color 57
			229-232 Preset Color 58
			233-236 Preset Color 59
			237-240 Preset Color 60
			241-244 Preset Color 61
			245-248 Preset Color 62
			249-252 Preset Color 63
			253-255 Preset Color 64
5	6	10	<b>DIMMER INTENSITY</b>
			0-255 Intensity 0 to 100%
		11	<b>DIMMER INTENSITY FINE</b>
			0-255 Dimmer Intensity FINE Adjustment
			<b>SHUTTER / STROBE</b>
			0-31 LEDs OFF
			32-63 LEDs ON
			64-95 Strobe Effect SLOW to FAST
			96-127 LEDs ON
			128-159 Pulse Effect SLOW to FAST
			160-191 LEDs ON
			192-223 Random Strobe SLOW to FAST
			224-255 LED ON
			<b>DIMMER CURVES</b>
			0-20 STANDARD
			21-40 STAGE
			41-60 TV
			61-80 ARCHITECTURAL
			81-100 THRATRE
			101-255 DEFAULT to UNIT CURVE SETTING
7	9	14	<b>ZOOM</b>
			0-255 NARROW to WIDE
			<b>ZOOM FINE</b>
		15	0-255 Zoom FINE Adjustment

## CLEANING AND MAINTENANCE



**C A U T I O N**

**Disconnect power before cleaning or maintenance.**

### CLEANING

Frequent cleaning is recommended to insure proper function, optimized light output, and an extended life. The frequency of cleaning depends on the environment in which the fixture operates: damp, smoky or particularly dirty environments can cause greater accumulation of dirt on the fixture's optics.

- Clean the external lens surface at least every 20 days with a soft cloth to avoid dirt/debris accumulation. Never use alcohol, solvents, or ammonia based cleaners.

### MAINTENANCE

Regular inspections are recommended to insure proper function and extended life. There are no user serviceable parts inside this fixture, please refer all other service issues to an authorized Elation service technician. Should you need any spare parts, please order genuine parts from your local Elation dealer.

Please refer to the following points during routine inspections:

- A detailed electric check by an approved electrical engineer every 3 months, to make sure the circuit contacts are in good condition and prevent overheating.
- Be sure all screws and fasteners are securely tightened at all times. Loose screws may fall out during normal operation resulting in damage or injury.
- Check for any deformations on the housing, color lenses, rigging hardware and rigging points (ceiling, suspension, trussing). Deformations in the housing could allow for dust to enter into the fixture. Damaged rigging points or unsecured rigging could cause the fixture to fall and seriously injure a person(s).
- Inspect all moving parts and make sure there are no signs of wear and rotate/move without imbalances.
- Electric power supply cables must not show any damage, material fatigue or sediments. Never remove the ground prong from the power cable.

# TECHNICAL SPECIFICATIONS

## FEATURES

Motorized 10° - 60° Zoom  
Selectable Dimming Curves  
Flicker Free Operation for TV and FILM

## SOURCE

7x 10W Osram™ QUAD Color (RGBW) LEDs  
50,000 Hour Average Life

## EFFECTS

64 Color Macros  
Strobe + Variable Strobe Macros  
Electronic Dimming: 0% - 100%

## COLOR

RGBW

## CONTROL / CONNECTIONS

3 DMX Channel Modes (7 / 9 / 15)  
5pin DMX In/Out  
4 Button Control Panel  
LCD Menu Display  
Power Cable In/Out  
Power Link Up To (15) Units at 120V (28) Units at 230V

## SIZE / WEIGHT

Length: 15.3" (388mm)  
Width: 7.5" (190mm)  
Vertical Height: 7.1" (180mm)  
Weight: 13.2 lbs. (6.0kg)

## ELECTRICAL / THERMAL

AC 100-240V - 50/60Hz  
220W Max Power Consumption  
Max Ambient Temperature 104°F (40°C)

## APPROVALS / RATINGS

CE | IP20

## INSTALLATION

Rigging: Dual Yoke / Floor Stand  
Working Position: Any (360°)



**Please Note: Specifications and improvements in the design of this unit and this manual are subject to change without any prior written notice.**

## PHOTOMETRIC DATA

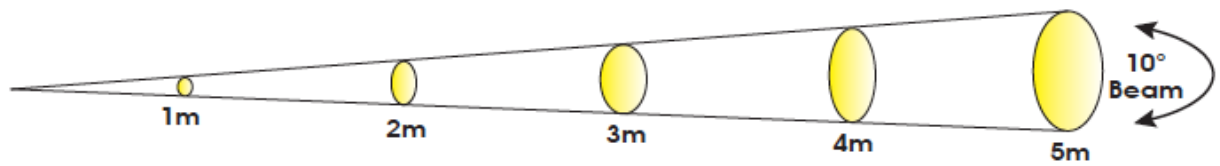

### 10° MIN ZOOM

Distance	m	ft	lux	fc	m	ft	lux	fc	m	ft	lux	fc	m	ft	lux	fc
	1	3.3				2				6.6				3		
Photometrics	lux	fc	lux	fc	lux	fc	lux	fc	lux	fc	lux	fc	lux	fc	lux	fc
RED	7,600	706	1,700	158	917	85	500	46	328	30						
BLUE	19,600	1,821	5,300	492	2,300	214	1,340	124	830	77						
GREEN	690	64	202	19	99	9	61	6	47	4						
WHITE	21,800	2,025	6,100	567	2,680	249	1,490	138	150	14						
FULL ON	47,500	4,413	12,700	1,180	5,000	465	3,200	297	1,950	181						

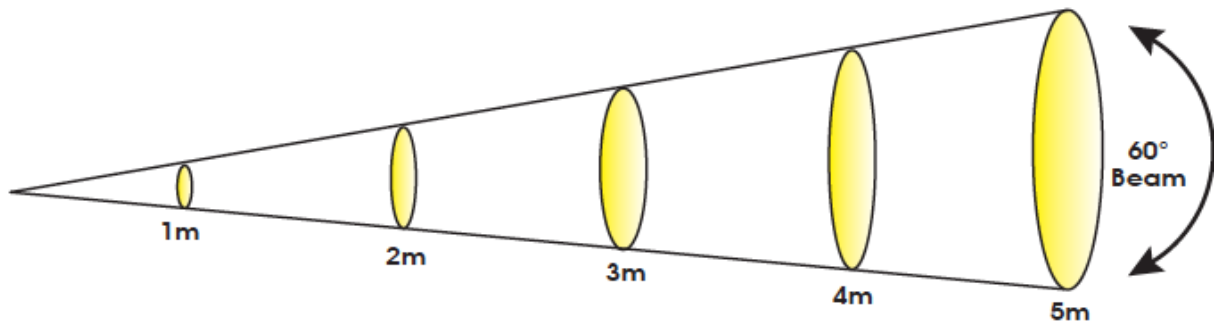

### 60° MAX ZOOM

Distance	m	ft	lux	fc	m	ft	lux	fc	m	ft	lux	fc	m	ft	lux	fc
	1	3.3				2				6.6				3		
Photometrics	lux	fc	lux	fc	lux	fc	lux	fc	lux	fc	lux	fc	lux	fc	lux	fc
RED	610	57	200	19	87	8	55	5	42	4						
BLUE	1,500	139	430	40	204	19	125	12	86	8						
GREEN	73	7	32	3	25	2	21	2	17	2						
WHITE	1,680	156	480	45	217	20	132	12	91	8						
FULL ON	3,680	342	980	91	440	41	265	25	160	15						

## DIMENSIONAL DRAWINGS

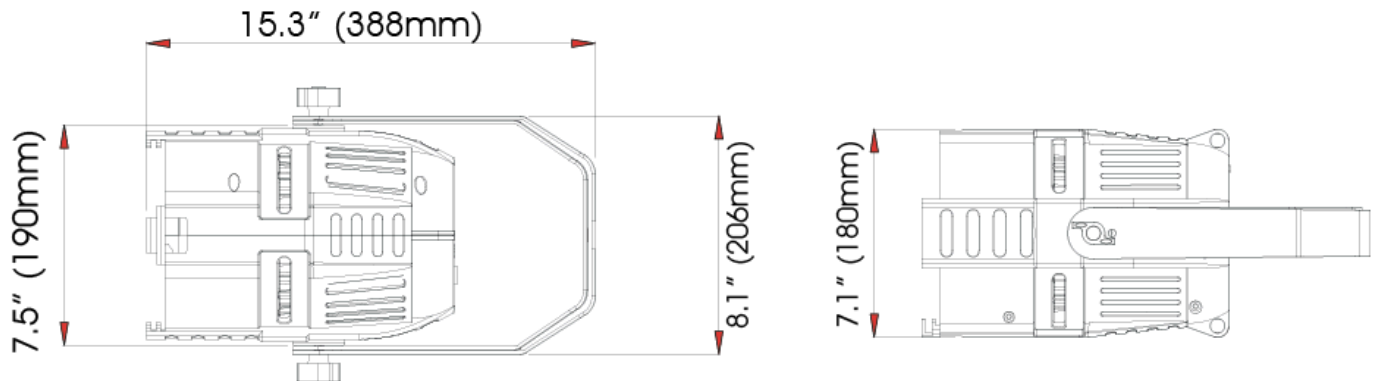

Please Note: Specifications and improvements in the design of this unit and this manual are subject to change without any prior written notice.

## OPTIONAL ACCESSORIES

<b>ORDER CODE</b>	<b>ITEM</b>
TRIGGER CLAMP	Heavy Duty Wrap Around Hook Style Clamp
EWDMXSYSTEM	Wireless DMX System (1 Transmitter, 1 Receiver)
AC5PDMX5PRO	5 ft. (1.5m) 5pin PRO DMX Cable
PLC3	3' (1m) PRO Link Cable
	Additional Cable Lengths Available



