

ARENA PAR ZOOM™

user manual

©2013 **ELATION PROFESSIONAL** all rights reserved. Information, specifications, diagrams, images, and instructions herein are subject to change without notice. ELATION PROFESSIONAL logo and identifying product names and numbers herein are trademarks of ELATION PROFESSIONAL. Copyright protection claimed includes all forms and matters of copyrightable materials and information now allowed by statutory or judicial law or hereinafter granted. Product names used in this document may be trademarks or registered trademarks of their respective companies and are hereby acknowledged. All non-ELATION brands and product names are trademarks or registered trademarks of their respective companies.

ELATION PROFESSIONAL and all affiliated companies hereby disclaim any and all liabilities for property, equipment, building, and electrical damages, injuries to any persons, and direct or indirect economic loss associated with the use or reliance of any information contained within this document, and/or as a result of the improper, unsafe, insufficient and negligent assembly, installation, rigging, and operation of this product.

Elation Professional USA | 6122 S. Eastern Ave. | Los Angeles, CA. 90040
323-582-3322 | 323-832-9142 fax | www.elationlighting.com | info@elationlighting.com

Elation Professional B.V. | Junostraat 2 | 6468 EW Kerkrade, Netherlands
+31 45 546 85 66 | +31 45 546 85 96 fax | www.elationlighting.eu | info@elationlighting.eu

CONTENTS

General Information	4
Warranty	6
Safety Instructions	7
General Guidelines	8
Fixture Overview	9
Installation	10
Understanding DMX	12
Fixture Menu	16
DMX Channel Functions And Values	21
Trouble Shooting	22
Cleaning and Maintenance	23
Technical Specifications	24
Optional Accessories	28
Declaration Of Conformity	29

GENERAL INFORMATION

INTRODUCTION

Congratulations, you have just purchased one of the most innovative and reliable lighting fixtures on the market today! The **ARENA PAR ZOOM™** has been designed to perform reliably for years when the guidelines in this booklet are followed. Please read and understand the instructions in this manual carefully and thoroughly before attempting to operate this unit. These instructions contain important information regarding safety during use and maintenance.

UNPACKING

Thank you for purchasing the **ARENA PAR ZOOM™** by Elation Professional®. Every **ARENA PAR ZOOM™** has been thoroughly tested and has been shipped in perfect operating condition. Carefully check the shipping carton for damage that may have occurred during shipping. If the carton appears to be damaged, carefully inspect your unit for damage and be sure all accessories necessary to operate the unit have arrived intact. In the event damage has been found or parts are missing, please contact our customer support team for further instructions. Please do not return this unit to your dealer without first contacting customer support at the number listed below. Please do not discard the shipping carton in the trash. Please recycle whenever possible.

BOX CONTENTS

- (1) Power Cable
- Manual & Warranty Card

MANUAL UPDATES

Please check www.elationlighting.com for the latest revision/update of this manual.

CUSTOMER SUPPORT

Elation Professional® provides a customer support line, to provide set up help and to answer any question should you encounter problems during your set up or initial operation. You may also visit us on the web at www.elationlighting.com for any comments or suggestions. For service related issue please contact Elation Professional®. Service Hours are Monday through Friday 8:00 a.m. to 5:00 p.m. PST.

Voice: 323-582-3322

Fax: 323-832-9142

E-mail: support@elationlighting.com

Forum: www.ElationLighting.com/forum

WARRANTY REGISTRATION

The **ARENA PAR ZOOM™** carries a two-year (730 days) limited warranty. Please fill out the enclosed warranty card to validate your purchase. All returned service items whether under warranty or not, must be freight pre-paid and accompany a return authorization (R.A.) number. The R.A. number must be clearly written on the outside of the return package. A brief description of the problem as well as the R.A. number must also be written down on a piece of paper and included in the shipping container. If the unit is under warranty, you must provide a copy of your proof of purchase invoice. Items returned without a R.A. number clearly marked on the outside of the package will be refused and returned at customer's expense. You may obtain a R.A. number by contacting customer support at 323-582-3322.



IMPORTANT NOTICE!

There are no user serviceable parts inside this unit. Do not attempt any repairs yourself; doing so will void your manufactures warranty. Damages resulting from modifications to this fixture and/or the disregard of safety and general user instructions found in this user manual void the manufactures warranty and are not subject to any warranty claims and/or repairs.

2-YEAR LIMITED WARRANTY

A. Elation Professional® hereby warrants, to the original purchaser, Elation Professional® products to be free of manufacturing defects in material and workmanship for a period of two years, (730 days) from the date of purchase. This warranty shall be valid only if the product is purchased within the United States of America, including possessions and territories. It is the owner's responsibility to establish the date and place of purchase by acceptable evidence, at the time service is sought.

B. For warranty service, send the product only to the Elation Professional® factory. All shipping charges must be pre-paid. If the requested repairs or service (including parts replacement) are within the terms of this warranty, Elation Professional® will pay return shipping charges only to a designated point within the United States. If the entire instrument is sent, it must be shipped in its original package. No accessories should be shipped with the product. If any accessories are shipped with the product, Elation Professional® shall have no liability what so ever for loss of or damage to any such accessories, nor for the safe return thereof.

C. This warranty is void if the serial number has been altered or removed; if the product is modified in any manner which Elation Professional® concludes, after inspection, affects the reliability of the product; if the product has been repaired or serviced by anyone other than the Elation Professional® factory unless prior written authorization was issued to purchaser by Elation Professional®; if the product is damaged because not properly maintained as set forth in the instruction manual.

D. This is not a service contract, and this warranty does not include maintenance, cleaning or periodic check-up. During the period specified above, Elation Professional® will replace defective parts at its expense, and will absorb all expenses for warranty service and repair labor by reason of defects in material or workmanship. The sole responsibility of Elation Professional® under this warranty shall be limited to the repair of the product, or replacement thereof, including parts, at the sole discretion of Elation Professional®. All products covered by this warranty were manufactured after January 1, 1990, and bare identifying marks to that effect.

E. Elation Professional® reserves the right to make changes in design and/or improvements upon its products without any obligation to include these changes in any products theretofore manufactured.

F. No warranty, whether expressed or implied, is given or made with respect to any accessory supplied with products described above. Except to the extent prohibited by applicable law, all implied warranties made by Elation Professional® in connection with this product, including warranties of merchantability or fitness, are limited in duration to the warranty period set forth above. And no warranties, whether expressed or implied, including warranties of merchantability or fitness, shall apply to this product after said period has expired. The consumer's and or Dealer's sole remedy shall be such repair or replacement as is expressly provided above; and under no circumstances shall Elation Professional® be liable for any loss or damage, direct or consequential, arising out of the use of, or inability to use, this product.

G. This warranty is the only written warranty applicable to Elation Professional® Products and supersedes all prior warranties and written descriptions of warranty terms and conditions heretofore published.

SAFETY INSTRUCTIONS



The **ARENA PAR ZOOM™** is an extremely sophisticated piece of electronic equipment. To guarantee a smooth operation, it is important to follow the guidelines in this manual. The manufacturer of this device will not accept responsibility for damages resulting from the misuse of this fixture due to the disregard of the information printed in this manual.



This device falls under **PROTECTION CLASS 1**. It's essential this device is grounded properly, and only qualified personnel perform all electrical connections.



CAUTION!

Never touch the device during operation!
The housing may heat up



CAUTION!

Never look directly into the light source,
as sensitive persons may suffer an epileptic shock.



CAUTION!

Keep this device away from rain and moisture !



CAUTION!

Unplug mains lead before opening the housing.

- For proper operation, follow the **Installation** guidelines described on page **10** of this manual. Only qualified and certified personnel should perform installation of this fixture and only the original rigging parts (brackets) included with this fixture should be used for installation. Any modifications will void the original manufacturer's warranty and increase the risk of damage and/or personal injury.
- Never look directly into the light source of this fixture to prevent risk of injury to your retina, which may induce blindness. Those suffering from **EPILEPSY** should avoid looking directly into the light source of this unit at all times.
- The fan and air inlets must remain clean and never blocked. Allow approx. 6" (15cm) between this fixture and other devices or a wall for proper cooling.
- Always disconnect from main power source before performing any type of service and/or cleaning procedure. Only handle the power cord by the plug end, never pull out the plug by tugging the wire portion of the cord.
- Do not operate this fixture if the power cord has become frayed, crimped and/or damaged. If the power cord is damaged, replace it immediately with a new one of similar power rating.

GENERAL GUIDELINES

- **NEVER OPEN THIS FIXTURE WHILE IN USE!**
- During the initial operation of this fixture, a light smoke or smell may emit from the interior of the fixture. This is a normal process and is caused by excess paint in the interior of the casing burning off from the heat associated with the lamp and will decrease gradually over time.
- This fixture is a professional lighting effect designed for **INDOOR / DRY LOCATIONS ONLY** on stage, in nightclubs, theatres, etc.
- Please make sure there are **NO FLAMMABLE MATERIALS** close to the fixture while operating, to prevent any fire hazard.
- The fixture must be installed in a location with adequate ventilation, at least 1.5 feet (.5m) from adjacent surfaces. Be sure no air ventilation slots are blocked.
- Do not attempt installation and/or operation without proper knowledge how to do so.
- Do not permit operation by persons who are not qualified for operating this type of theatrical fixture. Most damages are the result of operations by nonprofessionals.
- Consistent operational breaks may ensure the fixture will function properly for many years to come.
- Do not shake fixture, avoid brute force when installing and/or operating the device.
- Always install the fixture with an appropriate safety cable. When installing the fixture in a suspended environment, always use mounting hardware that is no less than M10 x 25 mm, also be sure the hardware is insert in the pre-arranged screw holes in the bracket of the fixture.
- Please use the original packaging and materials to transport the fixture in for service.
- Fixture surface temperature may reach up to **85°C**. **DO NOT TOUCH** the housing bare-hand during its operation. Turn OFF the power and allow approximately 15 minutes for the fixture to cool down before replacing or serving.

FIXTURE OVERVIEW

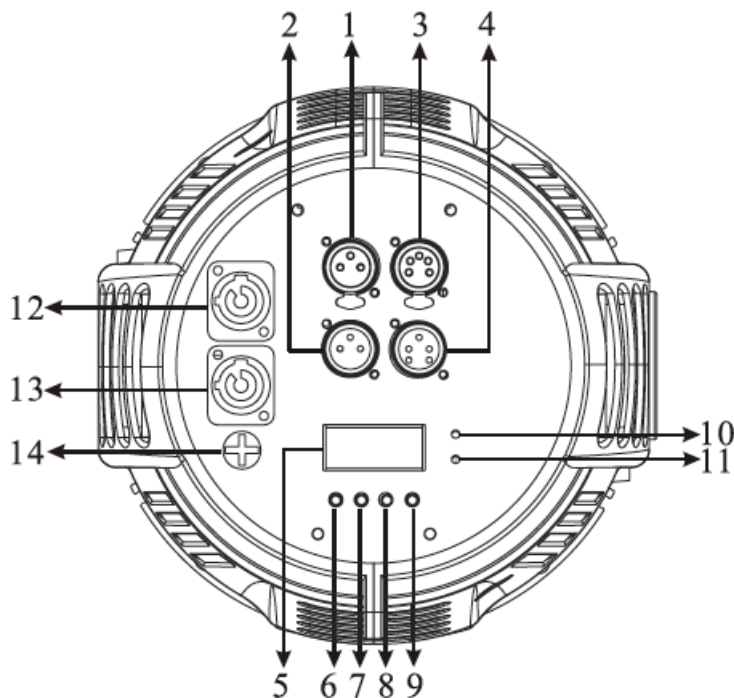

- 1: 3pin DMX IN
- 2: 3pin DMX OUT
- 3: 5pin DMX IN
- 4: 5pin DMX OUT
- 5: Menu Function Display
- 6: MODE Button
- 7: UP Button
- 8: DOWN Button
- 9: ENTER Button
- 10: Power ON
- 11: DMX Signal
- 12: PowerCON IN
- 13: PowerCON OUT
- 14: Fuse

- 1. **3pin DMX IN** - DMX signal input
- 2. **3pin DMX OUT** - DMX signal output
- 3. **5pin DMX IN** - DMX signal input
- 4. **5pin DMX OUT** - DMX signal output
- 5. **Menu Function Display** - Displays function menus and options
- 6. **MODE Button** - Used to select programming functions
- 7. **UP Button** - Used to toggle forward through selected menu functions
- 8. **DOWN Button** - Used to toggle backward through selected menu functions
- 9. **ENTER Button** - Used to confirm selected menu functions
- 10. **Power ON** - Indicates power is ON
- 11. **DMX Signal** - Power connection to power source
- 12. **PowerCON IN** - Power supply input to fixture
- 13. **PowerCON OUT** - Power link output to next fixture
- 14. **Fuse** - Fuse protection against current damage

INSTALLATION



CAUTION!

Please consider the GB7000.15/EN60598-2-17 and the other respective national norms during the installation. The installation must only be carried out by a qualified person.



CAUTION!

The electric connection must only be carried out by a qualified electrician.



CAUTIONS

- The maximum recommended ambient temperature is **104°F (40°C)**.
Do not use the fixture above this temperature.
- For added protection, mount the fixture in areas outside walking paths, seating areas, or in areas where unauthorized personnel might reach the fixture.
- Before mounting the fixture to any surface, make sure the installation area can hold a minimum point load of 10 times the weight of the fixture. **(165 lbs / 75 kgs)**
- Fixture installation must always be secured with a secondary safety attachment, such as an appropriate safety cable.
- Never stand directly below the device when mounting, removing or servicing the fixture.
- Be sure the fixture is kept at least 0.5m (1.5 feet) away from any flammable materials (decoration etc.).



POWER LINKING

**120V 60Hz - ONLY (4) devices may be linked together for power.
Connect device number #5 to a different power source.**

**230V 50Hz - ONLY (8) devices may be linked together for power.
Connect device number #9 to a different power source.**

MOUNTING POINTS

- Overhead mounting requires extensive experience, including amongst others calculating working load limits, installation material being used, and periodic safety inspection of all installation material and the device. If you lack these qualifications, do not attempt the installation yourself. Improper installation can result in bodily injury.
- Fixture is fully operational in any mounting position, hanging upside-down, side mounted, or on any flat level surface, and will remain steady no matter the angle of the fixture.

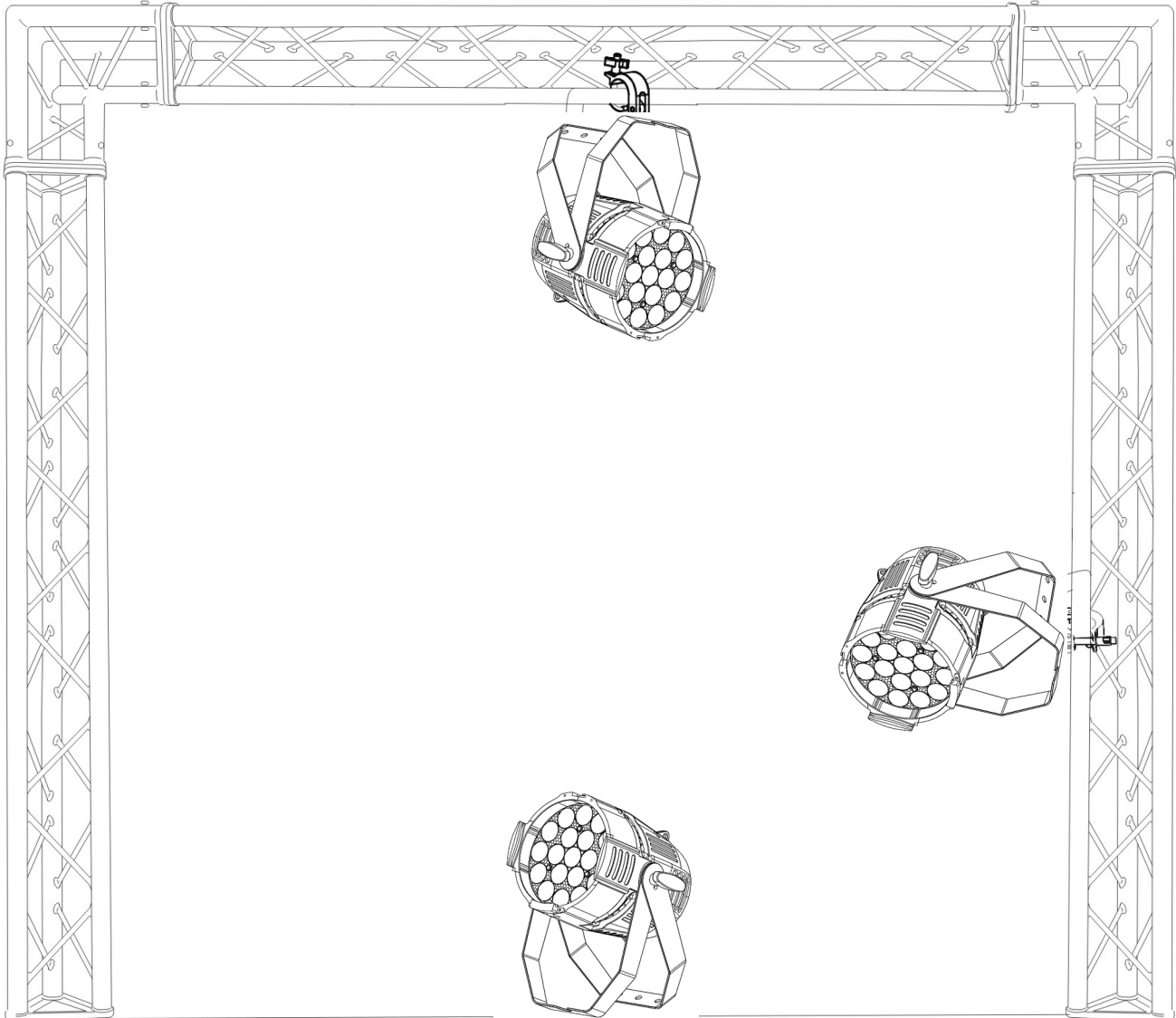

SAFETY CABLE

Always use a Safety Cable whenever installing this fixture in a suspended environment to ensure the fixture will not drop if the clamp fails.

UNDERSTANDING DMX

DMX-512

DMX is short for Digital Multiplex. This is a universal protocol used by most lighting and controller manufactures as a form of communication between intelligent fixtures and controllers. DMX allows all makes and models of different manufactures to be linked together and operate from a single controller. This is possible as long as all the fixtures and the controller are DMX compliant. A DMX controller sends the DMX data instructions to the fixture allowing the user to control the different aspects of an intelligent light. DMX data is sent out as serial data that travels from fixture to fixture via data “IN” and data “OUT” XLR terminals located on the fixtures (most controllers will only have output jacks).

DMX LINKING

To ensure proper DMX data transmission, always use proper DMX cables and a terminator. When using several DMX fixtures try to use the shortest cable path possible. Never split a DMX line with a “Y” style connector. The order in which the fixtures are connected in a DMX line does not influence the DMX addressing. For example; a fixture assigned a starting DMX address of 1 may be placed anywhere in the DMX chain, at the beginning, at the end, or anywhere in the middle. The DMX controller knows to send data assigned to address 1 to that fixture no matter where it is located in the DMX chain. The **ARENA PAR ZOOM™** can be controlled via DMX-512 protocol and the DMX address is set via the control menu.

DATA CABLE (DMX Cable) REQUIREMENTS (For DMX and Master/Slave Operation)

Your fixture and your DMX controller require a standard 3-pin or 5-pin XLR connector for data input and data output (see figure below). If you are making your own cables, be sure to use two conductor, shielded digital DMX cable rated at 120 ohms; this cable is designed for DMX transmission and may be purchased from your Elation dealer or at most professional lighting retailers. Your cables should be made with a male and female XLR connector on either end of the cable. Also, remember that a DMX line must be daisy chained and cannot be split, unless using an approved DMX splitter such as **Elation’s Opto Branch 4™, Opto Branch 8™, or DMX-Branch/4™**.

DMX Output
3-Pin XLR Socket



DMX Input
3-Pin XLR Socket



1: Ground
2: Data (-)
3: Data (+)

DMX Output
5-Pin XLR Socket



DMX Input
5-Pin XLR Socket

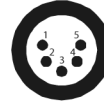

1: Ground
2: Data (-)
3: Data (+)
4: Open
5: Open



Be sure to follow the above figure when making your own cables. Do not use the ground lug on the XLR connector. Do not connect the cable's shield conductor to the ground lug or allow the shield conductor to come in contact with the XLR outer casing. Grounding the shield could cause a short circuit and erratic behavior.

DMX-512 CONTROLLER CONNECTION

Connect the provided XLR cable to the female XLR output of your controller and the other side to the male XLR input of the **ARENA PAR ZOOM™** (Please refer to the diagram below.). You can chain multiple panels together through serial linking. The cable that should be used is two conductor, shielded DMX cable with XLR input and output connectors. Always be sure daisy chain your in and out data connections, never split or “Y” your DMX connections unless you are using an approved DMX splitter such as **Elation's Opto Branch 4™, Opto Branch 8™, or DMX-Branch/4™**.

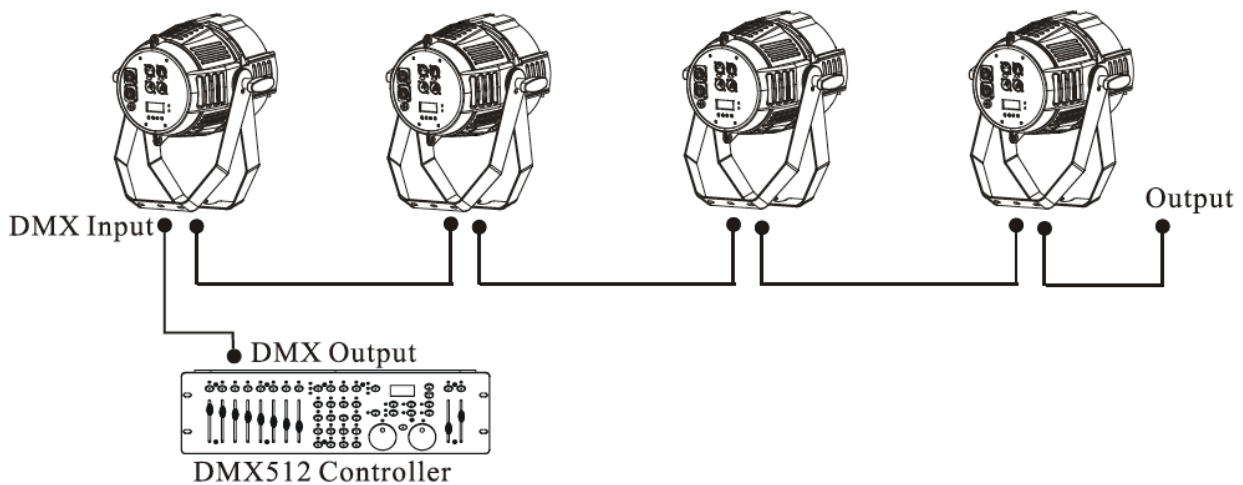

DMX-512 CONNECTION WITH DMX TERMINATOR

A DMX terminator should be used in all DMX lines especially in longer runs. The use of a terminator may avoid erratic behavior in your DMX line. A terminator is a 120 ohm 1/4 watt resistor that is connected between pins 2 and 3 of a male XLR connector (DATA + and DATA -). This fixture is inserted in the female XLR connector of the last fixture in your daisy chain to terminate the line. Using a line terminator will decrease the possibilities of erratic behavior.

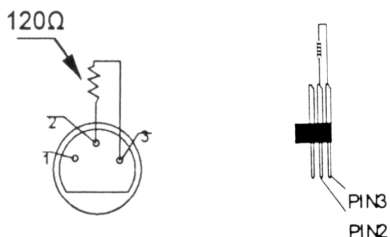

Termination reduces signal errors and avoids signal transmission problems and interference. It is always advisable to connect a DMX terminal, (Resistance 120 Ohm 1/4 W) between PIN 2 (DMX-) and PIN 3 (DMX +) of the last fixture.

5-Pin XLR DMX CONNECTORS

Some manufactures use 5-pin XLR connectors for DATA transmission in place of 3-pin. 5-pin XLR fixtures may be implemented in a 3-pin XLR DMX line. When inserting standard 5-pin XLR connectors in to a 3-pin line a cable adaptor must be used, these adaptors are readily available at most electric stores. The following chart details a proper cable conversion.

3-Pin XLR to 5-Pin XLR Conversion		
Conductor	3-Pin XLR Female (Out)	5-Pin XLR Male (In)
Ground/Shield	Pin 1	Pin 1
Data Compliment (- signal)	Pin 2	Pin 2
Data True (+ signal)	Pin 3	Pin 3
Not Used		Pin 4 - Do Not Use
Not Used		Pin 5 - Do Not Use

DMX ADDRESSING

All fixtures should be given a DMX starting address when using a DMX controller, so the correct fixture responds to the correct control signal. This digital starting address is the channel number from which the fixture starts to “listen” to the digital control information sent out from the DMX controller. The allocation of this starting DMX address is achieved by setting the correct DMX address on the digital display located on the back of the fixture.

You can set the same starting address for all fixtures or a group of fixtures, or set different address for each individual fixture. Be advised that setting all fixtures to the same DMX address will subsequently control all fixtures in the same fashion, in other words, changing the settings of one channel will affect all the fixtures simultaneously.

If you set each fixture to a different DMX address, each unit will start to “listen” to the channel number you have set, based on the quantity of control channels (DMX channels) of each fixture. That means changing the settings of one channel will only affect the selected fixture.

In the case of the **ARENA PAR ZOOM™**, when in 10 channel mode (default can also be set to 5 or 6), set the starting DMX address of the first unit to 1, the second unit to 11 (1 + 10), the third unit to 21 (11 + 10), the fourth unit to 31 (21 + 10) and so on. (See diagram below)

Channel Mode	Fixture 1 Address	Fixture 2 Address	Fixture 3 Address	Fixture 4 Address
5 channels	1	6	11	16
6 channels	1	7	13	19
10 channels	1	11	21	31

FIXTURE MENU

ON-BOARD SYSTEM MENU

The **ARENA PAR ZOOM™** comes with an easy to navigate system menu. The next section will detail the functions of each command in the system menu.

MENU FUNCTION DISPLAY

To select any of the menu functions, press the **MODE** button until the desired function is displayed. Select the function by pressing the **ENTER** button and the display will flash. Use the **UP** and **DOWN** buttons to change the mode. Once the desired mode has been selected, press the **ENTER** button to setup, or to go back to the main menu without making any changes press the **MENU** button again. Hold and press the **MODE** button about one second to exit the menu mode or wait for one minute and the fixture will exit the menu mode automatically. (The main functions and options are illustrated on the next page)

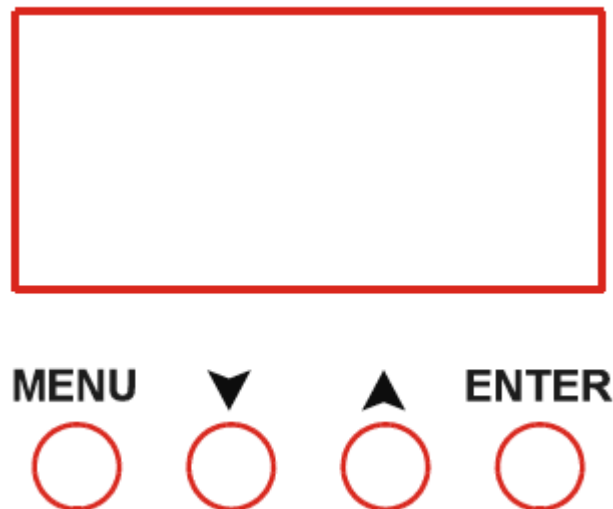

 The **MENU** display will lock when **NO** buttons are pressed for 30 seconds. When the display locks, none of the control panel buttons will respond. To unlock the display, press and hold the **MODE** button 3 seconds to access the menu options once again.

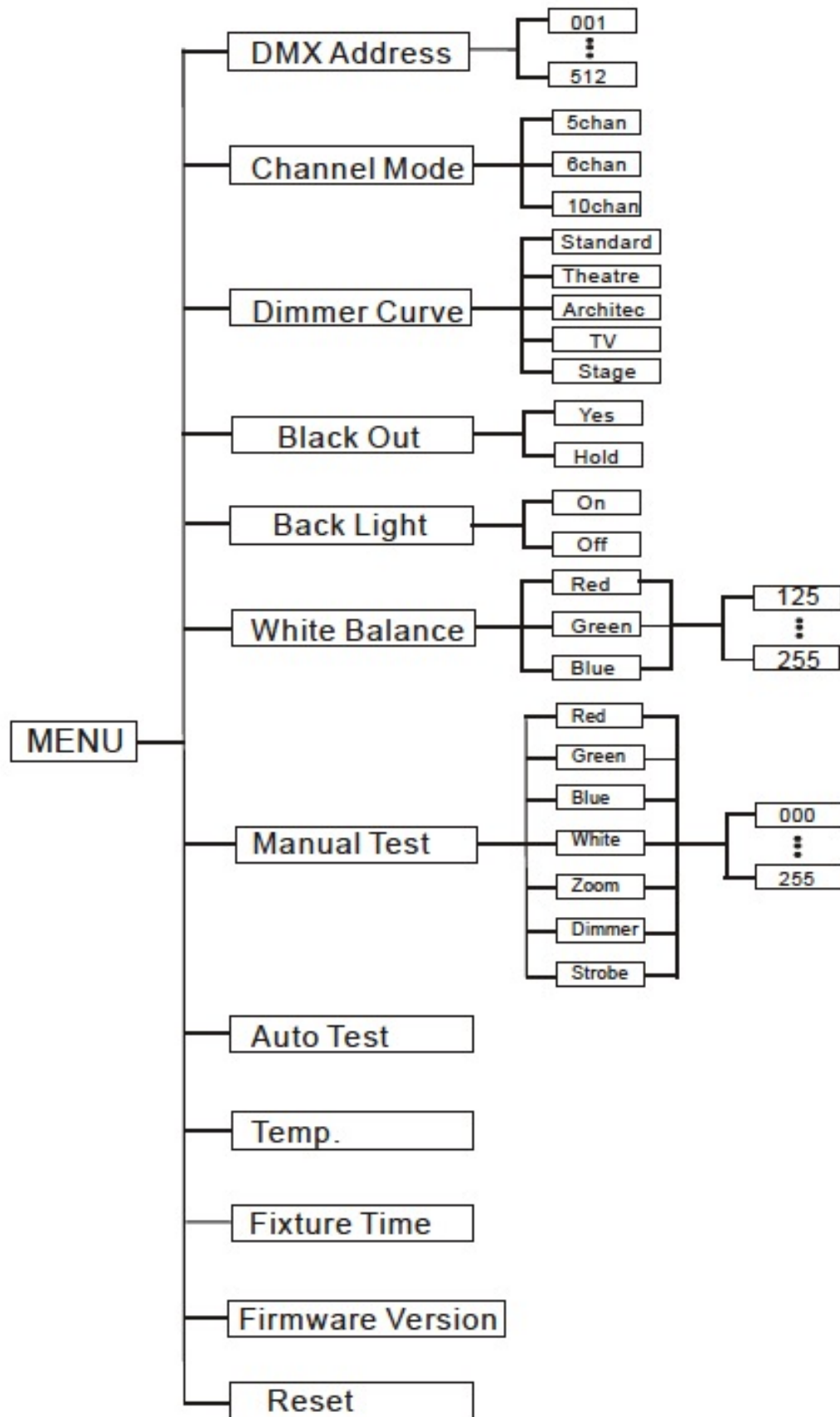

MAIN FUNCTIONS

DMX Address

Select the **DMX Address** menu, then press the **ENTER** button and the display will flash. Use the **UP** and **DOWN** buttons to change the **DMX Address (1-512)**, and then press the **ENTER** button to confirm selection. To return back to the previous menu functions without any change press the **MODE** button.

Channel Mode

Select the **Channel Mode** menu, then press the **ENTER** button and the display will flash. Use the **UP** and **DOWN** buttons to select desired **DMX Channel Mode (5chan, 6chan or 10chan)**. Once the desired mode has been selected, press the **ENTER** button to confirm selection. To return back to the previous menu functions without any change press the **MODE** button.

Dimmer Curve

Select the **Dimmer Curve** menu, then press the **ENTER** button and the display will flash. Use the **UP** and **DOWN** buttons to select the desired **Dimmer Curve Mode (Standard, Stage, TV, Architectural, Theatre)**. Once the desired mode has been selected, press the **ENTER** button to confirm selection. To return back to the previous menu functions without any change press the **MODE** button.

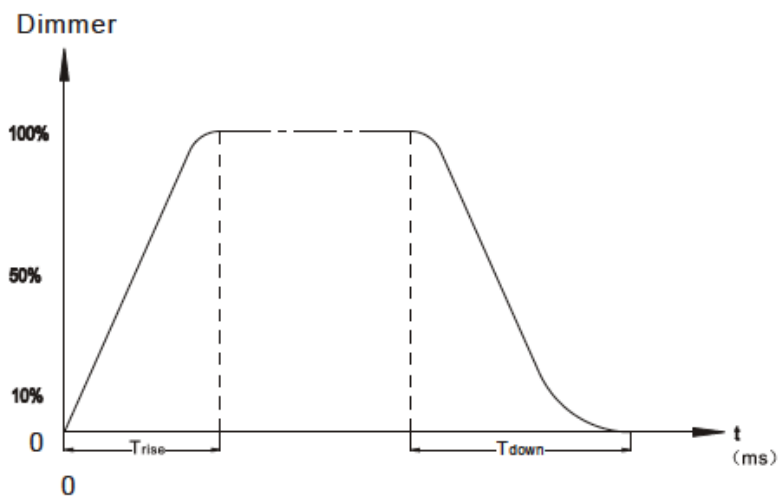

Ramp Effect	0 255 OS (Fade Time)		0 255 1S (Fade Time)	
	T _{rise} (ms)	T _{down} (ms)	T _{rise} (ms)	T _{down} (ms)
Standard	0	0	0	0
Stage	780	1100	1540	1660
TV	1180	1520	1860	1940
Architectural	1380	1730	2040	2120
Theatre	1580	1940	2230	2280

Black Out

Select the **Black Out** menu, then press the **ENTER** button and the display will flash. Use the **UP** and **DOWN** button to select **Yes** (blackout) or **Hold** (keeps last value set prior to signal loss). Once the desired mode has been selected, press the **ENTER** button to confirm selection. To return back to the previous menu functions without any change press the **MODE** button.

Back Light

Select the **Back Light** menu, then press the **ENTER** button and the display will flash. Use the **UP** and **DOWN** buttons to select **ON** or **OFF**. Once the desired mode has been selected, press the **ENTER** button to confirm selection. To return back to the previous menu functions without any change press the **MODE** button.

White Balance

Select the **White Balance** menu, then press the **ENTER** button and the display will flash. Use the **UP** and **DOWN** buttons to select the desired color (**Red, Green, Blue**) you wish to adjust. Press the **ENTER** button to confirm your selection and use **UP** and **DOWN** button to adjust the value (**125~255**). Once the desired value has been selected, press the **ENTER** button to confirm selection. To return back to the previous menu functions without any change press the **MODE** button.

Manual Test

Select the **Manual Test** menu, then press the **ENTER** button and the display will flash. Use the **UP** and **DOWN** buttons to select the desired function (**Red, Green, Blue, White, Zoom, Dimmer or Strobe**) you wish to test. Once the desired function has been selected, press the **ENTER** button and the displayed value will begin to flash. You can now adjust the values (**000~255**) by pressing the **UP** and **DOWN** buttons. Once you have completed testing press the **ENTER** button. To return back to the previous menu functions without any change press the **MODE** button.

Auto Test

Select the **Auto Test** menu, then press the **ENTER** button and the fixture will run the built-in program for self test. Press the **MODE** button to exit.

Temp.

Select the **Temp.** menu, then press the **ENTER** button and the display will show the current running temperature of the fixture. Press the **MODE** button to exit.

Fixture Time

Select the **Fixture Time** menu, then press the **ENTER** button and the display will show the total running time of the fixture. Press the **MODE** button to exit.

Firmware Version

Select the **Firmware Version** menu, then press the **ENTER** button and the display will show the software version of the fixture. Press the **MODE** button to exit.

Reset

Select the Reset menu, then press the **ENTER** button and the fixture will now reset itself.

DMX CHANNEL FUNCTIONS AND VALUES

ELATION® ARENA PAR ZOOM™			
DMX Channel Values / Functions (10 DMX Channels)			
Specifications subject to change without any prior written notice.			
MODE / CHANNEL			VALUE
5	6	10	FUNCTION
1	1	1	RED
			0-255 Red (0-Black , 255-100% Red)
2	2	2	GREEN
			0-255 Green (0-Black , 255-100% Green)
3	3	3	BLUE
			0-255 Blue (0-Black , 255-100% Blue)
4	4	4	WHITE
			0-255 White (0-Black , 255-100% White)
5			COLOR MACROS
			0-7 OPEN
			8-15 Preset Color 1
			16-23 Preset Color 2
			24-30 Preset Color 3
			31-38 Preset Color 4
			39-46 Preset Color 5
			47-54 Preset Color 6
			55-61 Preset Color 7
			62-69 Preset Color 8
			70-77 Preset Color 9
			78-85 Preset Color 10
			86-92 Preset Color 11
			93-100 Preset Color 12
			101-108 Preset Color 13
			109-116 Preset Color 14
			117-123 Preset Color 15
			124-131 Preset Color 16
			132-139 Preset Color 17
			140-147 Preset Color 18
			148-154 Preset Color 19
			155-162 Preset Color 20
			163-170 Preset Color 21
			171-178 Preset Color 22
			179-185 Preset Color 23
			186-193 Preset Color 24
			194-201 Preset Color 25
			202-209 Preset Color 26
			210-216 Preset Color 27
			217-224 Preset Color 28
			225-232 Preset Color 29
			233-240 Preset Color 30
241-247 Preset Color 31			
248-255 Preset Color 32			
6			SHUTTER / STROBE
			0-7 OFF
			8-15 LEDs ON
			16-131 Strobe Effect SLOW to FAST
			132-139 LEDs ON
			140-181 SLOW Open FAST Close
			182-189 LEDs ON
			190-231 SLOW Close FAST Open
			232-239 LEDs ON
			240-247 RANDOM Strobe
248-255 LEDs ON			

ELATION® ARENA PAR ZOOM™			
DMX Channel Values / Functions (10 DMX Channels)			
Specifications subject to change without any prior written notice.			
MODE / CHANNEL			FUNCTION
5	6	10	
		7	DIMMER INTENSITY
			Intensity 0 to 100%
5	5	8	ZOOM
			WIDE to NARROW
		9	COLOR TEMP
			Continuous WHITE color temperature control from 7200k to 3200k
	6	10	DIMMER CURVES
			0-41 STANDARD
			42-84 STAGE
			85-127 TV
			128-170 ARCHITECTURAL
			171-213 THRATRE
			214-255 DEFAULT to UNIT CURVE SETTING

TROUBLE SHOOTING

The following are a few common problems that may occur during operation, and some suggestions for easy troubleshooting:

A. The unit does not work, no light and the fan does not work

1. Check the connection of power and main fuse.
2. Measure the mains voltage on the main connector.
3. Check the power on LED.

B. Not responding to DMX controller

1. If DMX LED is not ON, check DMX connectors and cables to see if linked properly.
2. If DMX LED is ON, check DMX address settings and/or DMX polarity.
3. If there are intermittent DMX signal problems, check the pins on the DMX connectors and/or on the PCB of the fixture or the previous one.
4. Try using another DMX controller.
5. Check if the DMX cables run near or run alongside to high voltage cables that may cause damage and/or interference to the DMX interface circuit.

C. One of the channels is not working well

1. The stepper motor and/or the DMX cable connected to the PCB might be damaged.
2. The motor's drive IC on the PCB might be damaged.

CLEANING AND MAINTENANCE



CAUTION!

Disconnect from mains before starting maintenance operation.

CLEANING

Frequent cleaning is recommended to insure proper function, optimized light output, and an extended life. The frequency of cleaning depends on the environment in which the fixture operates: damp, smoky or particularly dirty environments can cause greater accumulation of dirt on the fixture's optics.

- Clean the external lens surface at least every 20 days with a soft cloth to avoid dirt/debris accumulation.
- Never use alcohol, solvents, or ammonia based cleaners.

MAINTENANCE

Regular inspections are recommended to insure proper function and an extended life.

There are no user serviceable parts inside this fixture, please refer all other service issues to an authorized Elation service technician. Should you need any spare parts, please order genuine parts from your local Elation dealer.

Please refer to the following points during routine inspections:

- A detailed electric check by an approved electrical engineer every three months, to make sure the circuit contacts are in good condition and prevent overheating.
- Be sure all screws and fasteners are securely tightened at all times. Loose screws may fall out during normal operation resulting in damage or injury as larger parts could fall.
- Check for any deformations on the housing, color lenses, rigging hardware and rigging points (ceiling, suspension, trussing). Deformations in the housing could allow for dust to enter into the fixture. Damaged rigging points or unsecured rigging could cause the fixture to fall and seriously injure a person(s).
- Electric power supply cables must not show any damage, material fatigue or sediments. Never remove the ground prong from the power cable.

TECHNICAL SPECIFICATIONS

FEATURES

1000-Watt Comparable Lumens Output
Motorized 10° - 60° Zoom
Selectable Dimming Curves & Color Temperatures (3200K - 7200K)
Flicker Free Operation for TV and FILM

SOURCE

19x 10W Osram™ QUAD Color (RGBW) LEDs
50,000 Hour Average Life

PHOTOMETRIC DATA

12,600 LUX @3M 10° Min Zoom
900 LUX @3M 60° Max Zoom

EFFECTS

Strobe + Variable Strobe Macros
Electronic Dimming: 0% - 100%

COLOR

RGBW

CONTROL / CONNECTIONS

3 DMX Channel Modes (5/6/10)
3pin & 5pin DMX In/Out
4 Button Control Panel
LCD Menu Display
Power In/Out
Power Link Up To (4) Units at 120V (8) Units at 230V

SIZE / WEIGHT

Length: 12.8" (324mm)
Width: 10.9" (276mm)
Vertical Height: 14.5" (368mm)
Weight: 15.9 lbs. (7.2kg)

ELECTRICAL / THERMAL

AC 100-240V - 50/60Hz
220W Max Power Consumption
-4°F (-20°C) to 104°F (40°C)

APPROVALS / RATINGS

CE | IP20

INSTALLATION

Rigging: Dual Yoke / Floor Stand
Yoke Hole Diameter: 0.47" (12mm)
Working Position: Any (360°)



Please Note: Specifications and improvements in the design of this unit and this manual are subject to change without any prior written notice.

PHOTOMETRIC DATA

RED LEDs	790 FC / 8500 LUX	390 FC / 4200 LUX	158 FC / 1700 LUX	90 FC / 970 LUX	58 FC / 620 LUX
GREEN LEDs	2415 FC / 26,000 LUX	1003 FC / 10,800 LUX	465 FC / 5000 LUX	251 FC / 2700 LUX	158 FC / 1700 LUX
BLUE LEDs	818 FC / 8800 LUX	35 FC / 380 LUX	15 FC / 160 LUX	8 FC / 90 LUX	6 FC / 63 LUX
WHITE LEDs	2926 FC / 31,500 LUX	1301 FC / 14,000 LUX	557 FC / 6000 LUX	307 FC / 3300 LUX	195 FC / 2100 LUX
FULL ON	6039 FC / 65,000 LUX	2741 FC / 29,500 LUX	1171 FC / 12,600 LUX	641 FC / 6900 LUX	409 FC / 4400 LUX

LUX x 0.0929 = FC

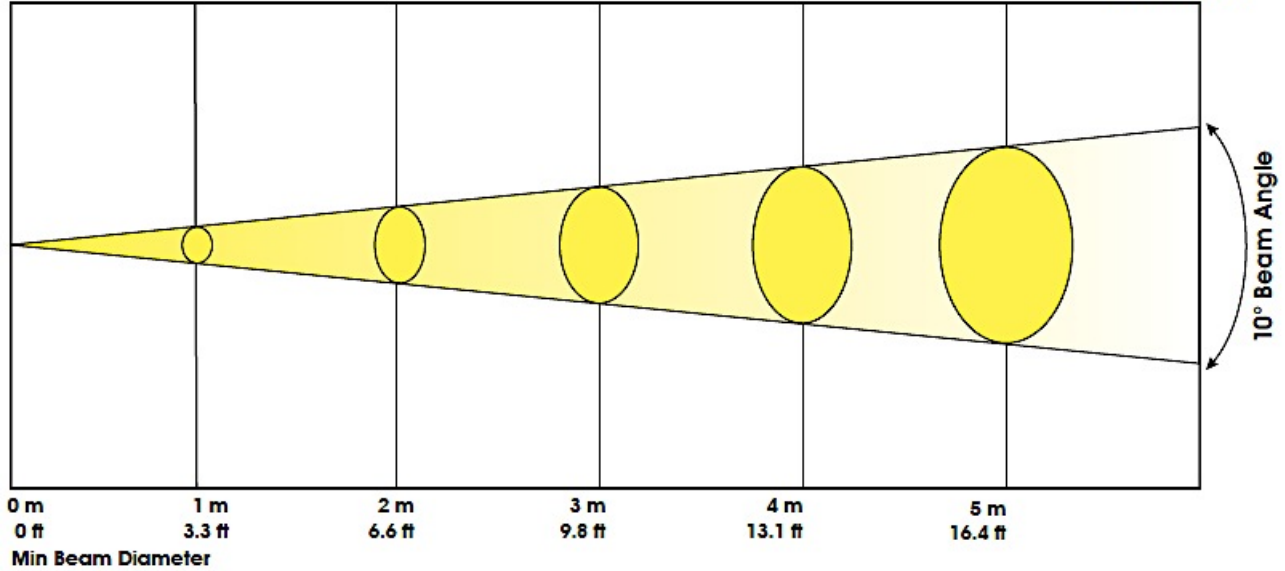

10° Beam Angle	∅ 0.4 m / ∅ 1.2 ft	∅ 0.5 m / ∅ 1.8 ft	∅ 0.7 m / ∅ 2.3 ft	∅ 0.9 m / ∅ 3.1 ft	∅ 1.1 m / ∅ 3.6 ft
----------------	--------------------	--------------------	--------------------	--------------------	--------------------

RED LEDs	93 FC / 1000 LUX	260 FC / 2800 LUX	12 FC / 130 LUX	8 FC / 84 LUX	5 FC / 55 LUX
GREEN LEDs	279 FC / 3000 LUX	74 FC / 800 LUX	35 FC / 380 LUX	20 FC / 220 LUX	13 FC / 140 LUX
BLUE LEDs	102 FC / 1100 LUX	3 FC / 31 LUX	1 FC / 16 LUX	1 FC / 10 LUX	1 FC / 8 LUX
WHITE LEDs	334 FC / 3600 LUX	88 FC / 951 LUX	43 FC / 460 LUX	23 FC / 250 LUX	16 FC / 170 LUX
FULL ON	669 FC / 7200 LUX	186 FC / 2000 LUX	84 FC / 900 LUX	50 FC / 540 LUX	33 FC / 360 LUX

LUX x 0.0929 = FC

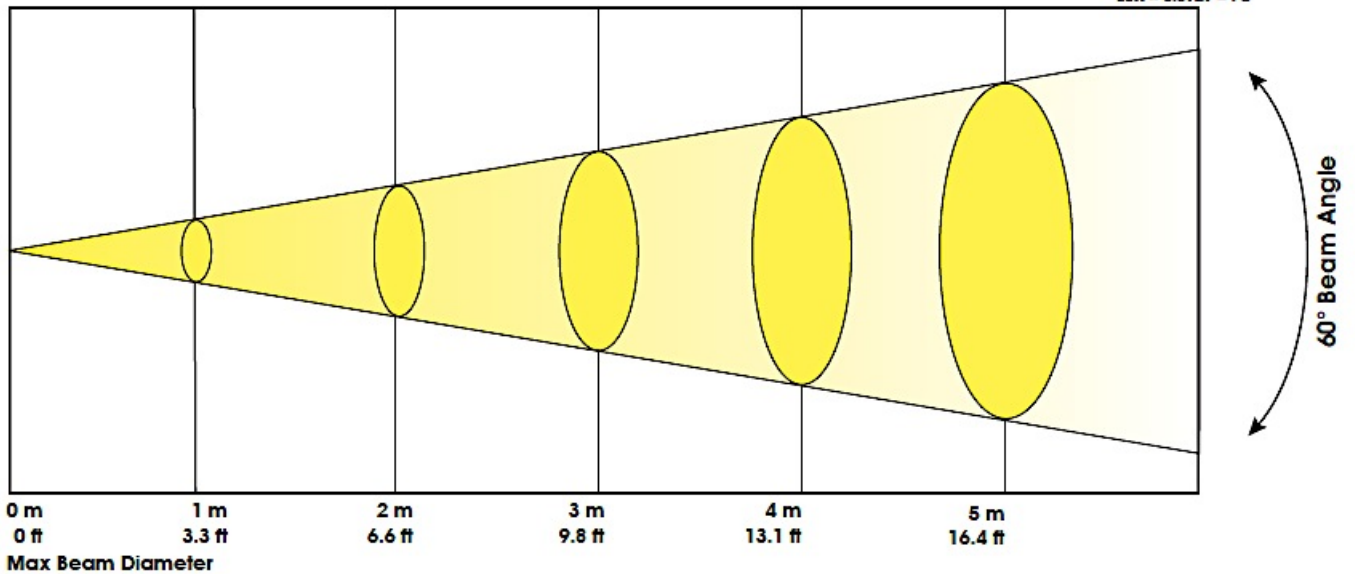

60° Beam Angle	∅ 1.7 m / ∅ 5.6 ft	∅ 3.0 m / ∅ 9.8 ft	∅ 4.4 m / ∅ 14.4 ft	∅ 5.8 m / ∅ 19.0 ft	∅ 7.5 m / ∅ 24.6 ft
----------------	--------------------	--------------------	---------------------	---------------------	---------------------

Please Note: Specifications and improvements in the design of this unit and this manual are subject to change without any prior written notice.

DIMENSIONAL DRAWINGS

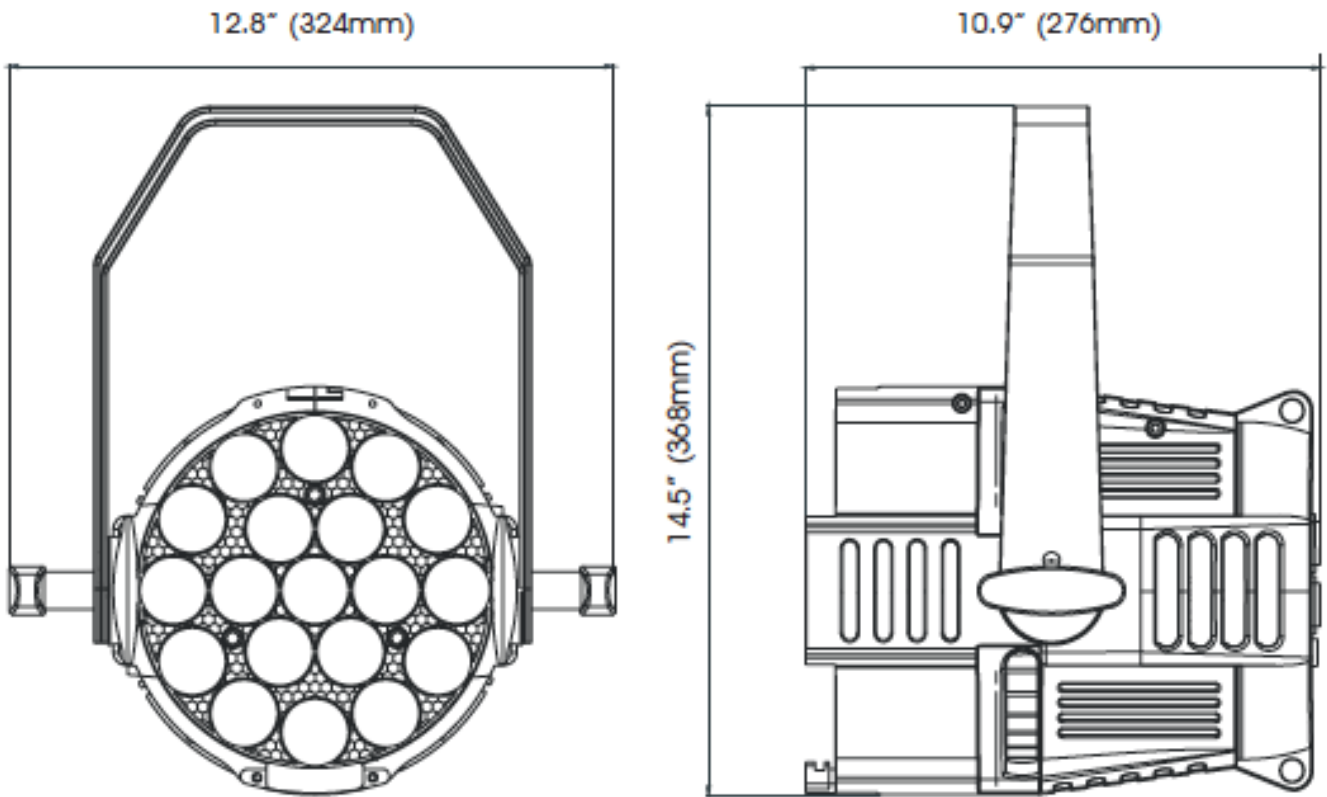

Please Note: Specifications and improvements in the design of this unit and this manual are subject to change without any prior written notice.

CIRCUIT SCHEMATICS

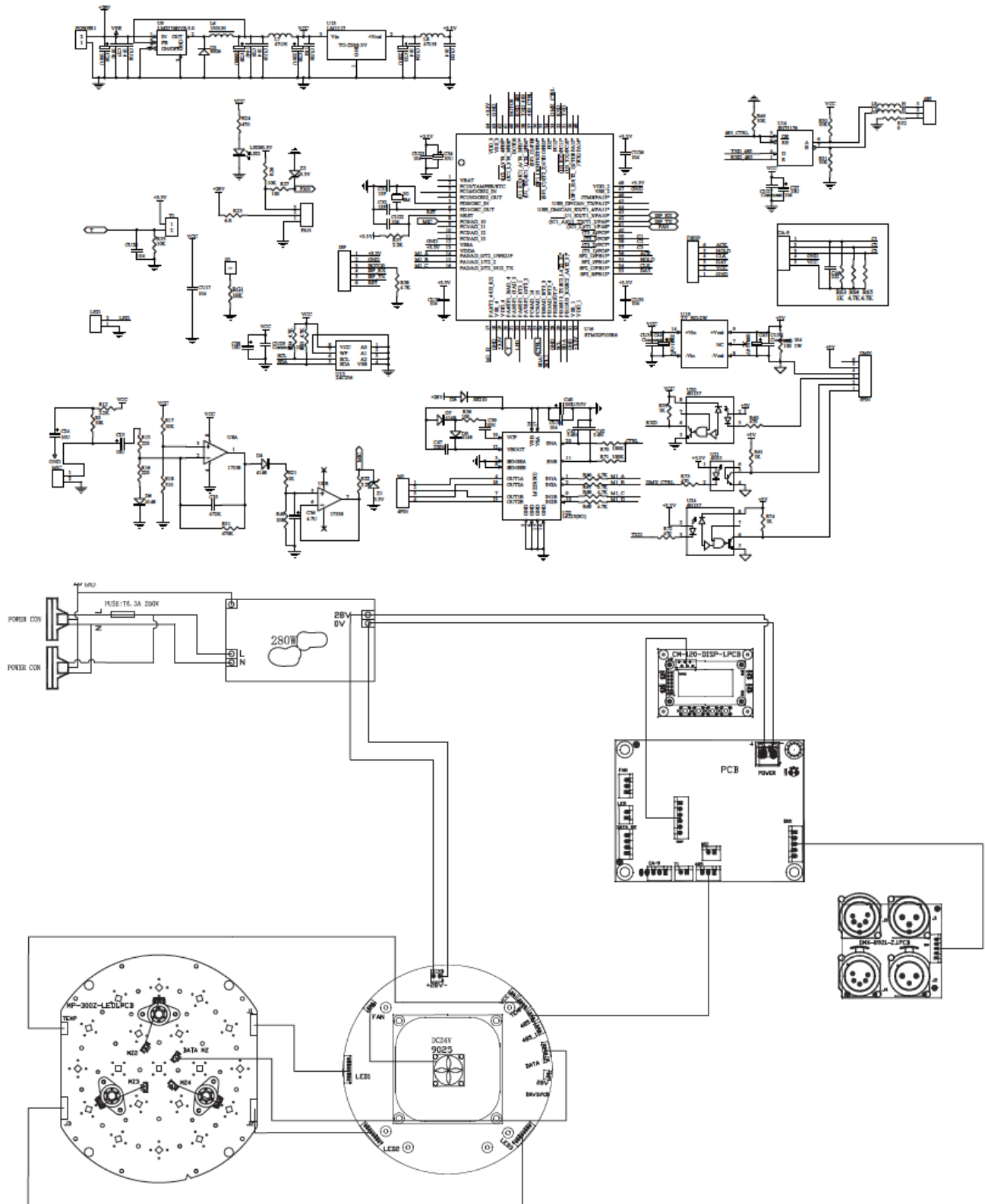

Please Note: Specifications and improvements in the design of this unit and this manual are subject to change without any prior written notice.

OPTIONAL ACCESSORIES

ORDER CODE	ITEM DESCRIPTION
TRIGGER CLAMP	Heavy Duty Wrap Around Hook Style Clamp
PLC3	3-foot (1m) Power Link Cable
PLC6	6-foot (1.8m) Power Link Cable
PLC10	10-foot (3m) Power Link Cable
PLC15	15-foot (4.5m) Power Link Cable
AC3PDMX5PRO	5-foot (1.5m) 3-pin PRO DMX Cable
AC3PDMX10PRO	10-foot (3m) 3-pin PRO DMX Cable
AC3PDMX15PRO	15-foot (4.5m) 3-pin PRO DMX Cable
AC3PDMX25PRO	25-foot (7.5m) 3-pin PRO DMX Cable
AC3PDMX50PRO	50-foot (15m) 3-pin PRO DMX Cable
AC3PDMX100PRO	100-foot (30m) 3-pin PRO DMX Cable
AC5PDMX5PRO	5-foot (1.5m) 5-pin PRO DMX Cable
AC5PDMX10PRO	10-foot (3m) 5-pin PRO DMX Cable
AC5PDMX15PRO	15-foot (4.5m) 5-pin PRO DMX Cable
AC5PDMX25PRO	25-foot (7.5m) 5-pin PRO DMX Cable
AC5PDMX50PRO	50-foot (15m) 5-pin PRO DMX Cable
AC5PDMX100PRO	100-foot (30m) 5-pin PRO DMX Cable

Declaration of Conformity

We declare that our products (lighting equipments) comply with the following specification and bears CE mark in accordance with the provision of the Electromagnetic Compatibility (EMC) Directive 89/336/EEC.

**EN55103-1: 2009 ; EN55103-2: 2009; EN62471: 2008;
EN61000-3-2: 2006 + A1:2009 + A2:2009; EN61000-3-3: 2008.**

&

Harmonized Standard

**EN 60598-1:2008 + All:2009; EN 60598-2-17:1989 + A2:1991; EN
62471:2008; EN 62493: 2010
Safety of household and similar electrical appliances
Part 1: General requirements**

