



## ACL CURTAIN™

SKU# ACL035

The new ACL CURTAIN™ is a versatile batten luminaire featuring (14) individual 15W RGBW 4-in-1 LEDs and the new advanced collimator optic lens producing a laser-like homogenized 4° color-changing beam from each lens which combined produce a 53° beam angle. Features include full individual pixel control, strobe, and selectable dimming curve effects, DMX, RDM (Remote Device Management), KlingNET™ and Art-NET support, 3/5pin XLR, powerCON, and RJ45 ethernet in/out connections, (4) button control full color 180° reversible menu display, 135W max power consumption, a multi-voltage universal auto switching power supply (100-240v), and included glare shield and frost filter.



### FEATURES

**Versatile 53° Beam Bar Luminaire**

**New Advanced Collimator Optic Lens**

**(14) Pixel Controlled 15W RGBW 4-in-1 LEDs**

**Laser-Like Homogenized 4° Color Changing Beams**

**Strobe and Selectable Dimming Curve Effects**

**DMX, KlingNET™ and Art-NET (DMX Over Ethernet)**

**Flicker Free Operation for Broadcast TV and FILM**

**Glare Shield and Frost Filter Included**



**Glare Shield + Frost Filter Installed**



Specifications are subject to change without notice ©Elation Professional 09/30/15

Elation Professional USA | 6122 S. Eastern Ave. | Los Angeles, CA. 90040  
323-582-3322 | 323-832-9142 fax | www.elationlighting.com | info@elationlighting.com

Elation Professional B.V. | Junostraat 2 | 6468 EW Kerkrade, Netherlands  
+31 45 546 85 66 | +31 45 546 85 96 fax | www.elationlighting.eu | info@elationlighting.eu

**PRODUCT SPECIFICATIONS**

**SOURCE**

(14) 15W RGBW 4-in-1 LEDs  
 100,000 Hour Average LED Life\*

\*LED Life may vary depending on several factors including but not limited to: Environmental Conditions, Power/Voltage, Usage Patterns (On-Off Cycling), Control and Dimming.

**PHOTOMETRIC DATA (53° Full ON)**

46,740 LUX 4,342 FC @3.3' (1m)  
 20,890 LUX 1,941 FC @6.6' (2m)  
 13,520 LUX 1,256 FC @9.8' (3m)  
 9,717 LUX 903 FC @13.1' (4m)  
 7,664 LUX 712 FC @16.4' (5m)

**EFFECTS**

Individual Pixel Control  
 Strobe and Selectable Dimming Curves

**COLOR**

RGBW

**CONTROL / CONNECTIONS**

(11) DMX Channel Modes:  
 (1CH:04 / 2CH:04 / 6 / 1CH:08 / 2CH:08 / 10 / 12 / 56 / 58 / 60 / 63)  
 RDM (Remote Device Management)  
 4 Button Touch Control Panel  
 Full Color 180° Reversible LCD Menu Display  
 3pin/5pin DMX In/Out  
 RJ45 Ethernet In/Out (KlingNET™ / Art-NET)  
 powerCON Power In/Out

**SIZE / WEIGHT**

Length: 43.3" (1100mm)  
 Width: 9.5" (241.2mm) (Glare Shield Installed)  
 Vertical Height: 6.8" (172.5mm)  
 Weight: 24.0 lbs. (10.9 kg)

**ELECTRICAL / THERMAL**

AC 100-240V - 50/60Hz  
 240W Max Power Consumption  
 Power Linking: 4pcs Max @110V / 9pcs Max @240V  
 5F to 113°F (-15°C to 45°C)

**APPROVALS / RATINGS**

CE | IP30

**INSTALLATION**

Rigging: Clamps (Not Included)  
 Working Position: Any (360°)

**INCLUDED ITEMS**

powerCON Cable  
 Glare Shield  
 Frost Filter



**PHOTOMETRIC DATA**

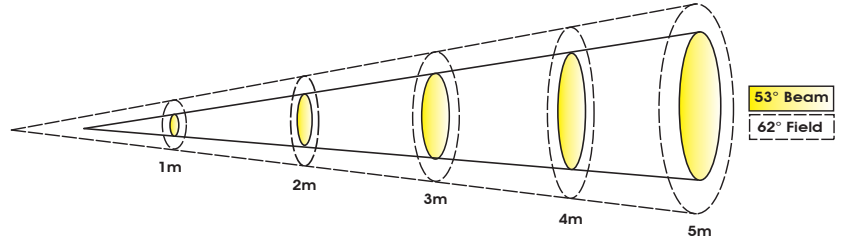

	1 m	3.3 ft	2 m	6.6 ft	3 m	9.8 ft	4 m	13.1 ft	5 m	16.4 ft
<b>53° Beam Diameter</b>	0.98	3.2	1.94	6.4	2.95	9.7	3.95	13.0	4.91	16.1
<b>62° Field Diameter</b>	1.17	3.8	2.39	7.8	3.58	11.7	4.7	15.4	5.85	19.2
	<b>lux</b>	<b>fc</b>	<b>lux</b>	<b>fc</b>	<b>lux</b>	<b>fc</b>	<b>lux</b>	<b>fc</b>	<b>lux</b>	<b>fc</b>
<b>RED LEDs</b>	7,902	734	3,652	339	2,440	227	1,757	163	1,313	122
<b>GREEN LEDs</b>	18,770	1,744	9,134	849	5,740	533	4,040	375	2,971	276
<b>BLUE LEDs</b>	4,537	421	1,924	179	1,337	124	951	88	761	71
<b>WHITE LEDs</b>	19,590	1,820	11,330	1,053	6,714	624	5,064	470	3,855	358
<b>FULL ON</b>	46,740	4,342	20,890	1,941	13,520	1,256	9,717	903	7,664	712

**DIMENSIONAL DIAGRAMS**

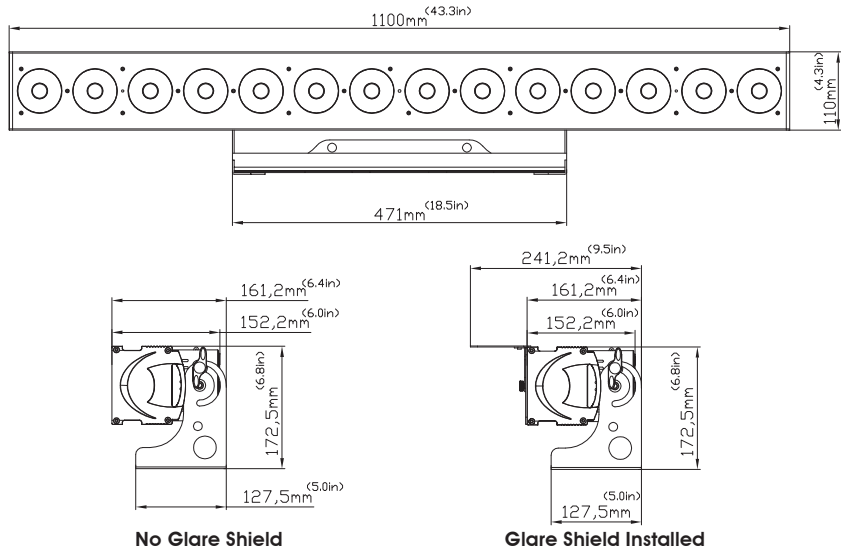

**OPTIONAL ACCESSORIES**

ORDER CODE	ITEM
<b>TRIGGER CLAMP</b>	Heavy Duty Wrap Around Hook Style Clamp
<b>EWDMSYSTEM</b>	Wireless DMX System (1 Transmitter, 1 Receiver)
<b>PLC3</b>	3' (1m) PowerCON PRO Link Cable
<b>CAT6PRO5</b>	5' (1.5m) CAT6 EtherCON Cable
<b>AC5PDMX5PRO</b>	5 ft. (1.5m) 5pin PRO DMX Cable
	Additional cable lengths available

