



## ACL BAR™

SKU# ACL024

The new ACL BAR™ is a versatile bar luminaire featuring (7) individual 15W RGBW 4-in-1 LEDs and the new advanced collimator optic lens, producing a laser-like homogenized 4° color-changing beam from each lens which combined produce a 31° beam angle. Features include full individual pixel control, strobe, and selectable dimming curve effects, DMX, RDM (Remote Device Management), or Art-NET support, 3/5pin XLR, powerCON, and RJ45 ethernet in/out connections, (4) button control full color 180° reversible menu display, 135W max power consumption, and a multi-voltage universal auto switching power supply (100-240v).



### FEATURES

**Versatile 31° Beam Bar Luminaire**

**New Advanced Collimator Optic Lens**

**(7) Pixel Controlled 15W RGBW 4-in-1 LEDs**

**Laser-Like Homogenized 4° Color Changing Beams**

**Strobe and Selectable Dimming Curve Effects**

**DMX, RDM, and Art-NET (DMX Over Ethernet) Support**

**Flicker Free Operation for Broadcast TV and FILM**

**Glare Shield and Frost Filter Included**



**Glare Shield + Frost Filter Installed**



**PRODUCT SPECIFICATIONS**

**SOURCE**

(7) 15W RGBW 4-in-1 LEDs  
100,000 Hour Average Lamp Life

**PHOTOMETRIC DATA (31° Full ON)**

43,380 LUX 4,030 FC @3.3' (1m)  
19,330 LUX 1,796 FC @6.6' (2m)  
12,180 LUX 1,132 FC @9.8' (3m)  
8,575 LUX 797 FC @13.1' (4m)  
6,247 LUX 580 FC @16.4' (5m)

**EFFECTS**

Individual Pixel Control  
Strobe and Selectable Dimming Curves

**COLOR**

RGBW

**CONTROL / CONNECTIONS**

(10) DMX Channel Modes:  
(1CH:04 / 2CH:04 / 6 / 8 / 10 / 12 / 28 / 30 / 32 / 35)  
RDM (Remote Device Management)  
4 Button Touch Control Panel  
Full Color 180° Reversible LCD Menu Display  
8 / 16 Bit Resolution Adjustable Movement  
3pin/5pin DMX In/Out  
RJ45 Ethernet In/Out (Art-NET)  
powerCON Power In/Out

**SIZE / WEIGHT**

Length: 21.6" (550mm)  
Width: 9.5" (241.2mm) (Glare Shield Installed)  
Vertical Height: 6.8" (172.5mm)  
Weight: 15.0 lbs. (6.8 kg)

**ELECTRICAL / THERMAL**

AC 100-240V - 50/60Hz  
135W Max Power Consumption  
5F to 113°F (-15°C to 45°C)

**APPROVALS / RATINGS**

CE | IP30



**INSTALLATION**

Rigging: Clamps (Not Included)  
Working Position: Any (360°)

**INCLUDED ITEMS**

powerCON Cable  
Glare Shield  
Frost Filter

**PHOTOMETRIC DATA**

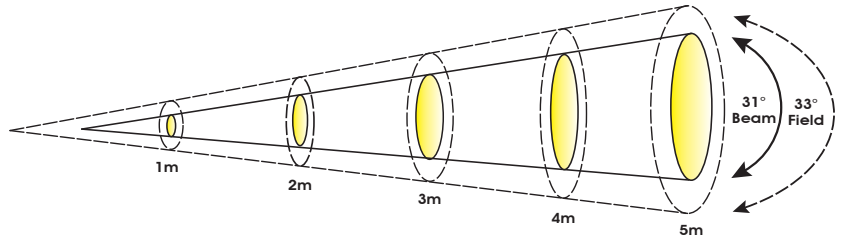

	1 m	3.3 ft	2 m	6.6 ft	3 m	9.8 ft	4 m	13.1 ft	5 m	16.4 ft
31° Beam Diameter	0.53	1.7	1.08	3.5	1.61	5.3	2.15	7.1	2.68	8.8
33° Field Diameter	0.58	1.9	1.14	3.7	1.62	5.3	2.21	7.3	2.75	9.0
	lux	fc	lux	fc	lux	fc	lux	fc	lux	fc
RED LEDs	7,828	727	3,620	336	2,182	203	1,590	148	1,157	107
GREEN LEDs	18,900	1,756	7,087	658	5,001	465	3,254	302	2,577	239
BLUE LEDs	4,148	385	1,870	174	1,159	108	810	75	575	53
WHITE LEDs	19,870	1,846	9,147	850	6,196	576	4,406	409	2,936	273
FULL ON	43,380	4,030	19,330	1,796	12,180	1,132	8,575	797	6,247	580

**DIMENSIONAL DIAGRAMS**

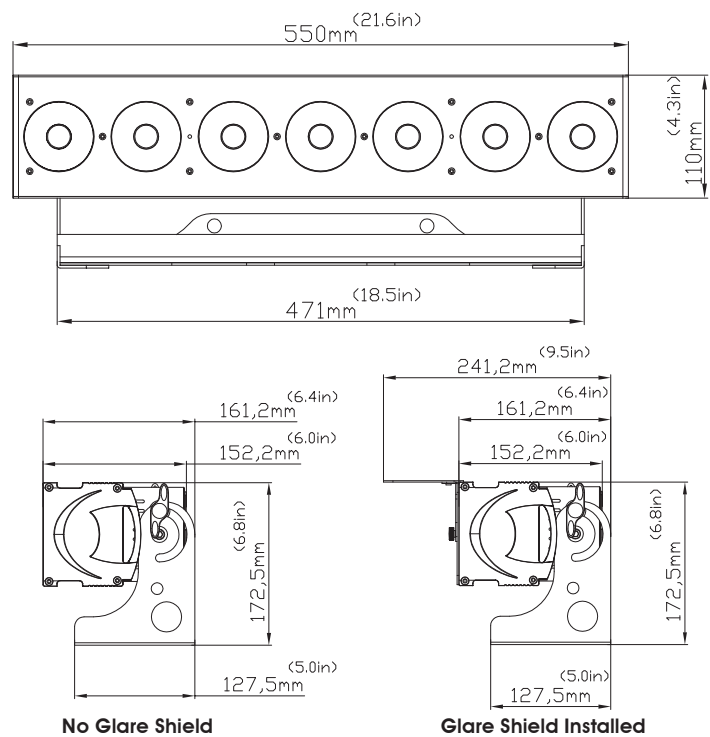

**OPTIONAL ACCESSORIES**

ORDER CODE	ITEM
TRIGGER CLAMP	Heavy Duty Wrap Around Hook Style Clamp
EWDMSYSTEM	Wireless DMX System (1 Transmitter, 1 Receiver)
PLC3	3' (1m) PowerCON PRO Link Cable
CAT6PRO5	5' (1.5m) CAT6 EtherCON Cable
AC5PDMX5PRO	5 ft. (1.5m) 5pin PRO DMX Cable
	Additional cable lengths available

