



ACL 360i™

SKU# ACL078

The new ACL 360i™ is an amazing single beam moving effect luminaire featuring a single 60W RGBW 4-in-1 LED and the new advanced collimator optic lens, which produces a laser-like homogenized 4° color-changing beam. Features 10 and 45 degree frost lens options (included), fast and precise 16-bit continuous full 360° pan and tilt rotation, strobe, and selectable dimming curve effects, DMX, RDM (Remote Device Management), KlingNET™ and Art-NET support, 5pin XLR, Locking Power Cable, and RJ45 ethernet in/out connections, (6) button control full color 180° reversible menu display, 110W max power consumption, and a multi-voltage universal auto switching power supply (100-240v).

FEATURES

Amazing 4° Single Beam Moving Effect Luminaire

New Advanced Collimator Optic Lens

60W RGBW 4-in-1 LED

Laser-Like Homogenized Color Changing Beam

10° and 45° Frost Lens Options Included

Fast and Precise 16-Bit Continuous 360° Pan/Tilt Rotation

Strobe and Selectable Dimming Curve Effects

RDM, KlingNET™ and Art-NET (DMX Over Ethernet)

Flicker Free Operation for Broadcast TV and FILM



PRODUCT SPECIFICATIONS

SOURCE

60W RGBW 4-in-1 LED
100,000 Hour Average LED Life*

*LED Life may vary depending on several factors including but not limited to: Environmental Conditions, Power/Voltage, Usage Patterns (On-Off Cycling), Control and Dimming.

PHOTOMETRIC DATA

30,601 LUX 2,843 FC @6.6' (2m)
12,955 LUX 1,204 FC @9.8' (3m)
7,687 LUX 714 FC @13.1' (4m)
5,112 LUX 475 FC @16.4' (5m)

EFFECTS

Strobe and Selectable Dimming Curves
Color Macros

COLOR

RGBW

CONTROL / CONNECTIONS

(5) DMX Channel Modes (16 / 18 / 20) (17 / 15)
RDM (Remote Device Management)
6 Button Touch Control Panel
Full Color 180° Reversible LCD Menu Display
8 / 16 Bit Resolution Adjustable Movement
5pin DMX In/Out
RJ45 Ethernet In/Out (KlingNET™ / Art-NET)
Locking Power Cable In/Out

SIZE / WEIGHT

Length: 8.7" (222mm)
Width: 7.3" (186mm)
Vertical Height: 13.0" (330mm)
Weight: 12.0 lbs. (5.2 kg)

ELECTRICAL / THERMAL

AC 100-240V - 50/60Hz
110W Max Power Consumption
5F to 113°F (-15°C to 45°C)

APPROVALS / RATINGS

CE | IP30

INSTALLATION

Rigging: Clamps (Not Included)
Working Position: Any (360°)

INCLUDED ITEMS

10° Frost Lens
45° Frost Lens
Omega Bracket
Locking Power Cable



10° and 45° Frost Lens (included)



PHOTOMETRIC DATA

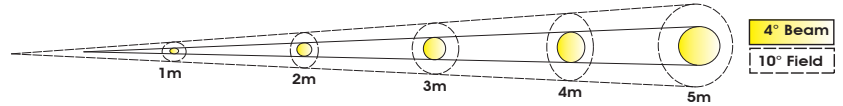

	2 m	6.6 ft	3 m	9.8 ft	4 m	13.1 ft	5 m	16.4 ft
4° Beam Diameter	0.15	0.5	0.24	0.8	0.33	1.1	0.41	1.3
10° Field Diameter	0.35	1.1	0.52	1.7	0.7	2.3	0.87	2.9
	lux	fc	lux	fc	lux	fc	lux	fc
RED LEDs	6,934	644	3,338	310	1,722	160	1,149	107
GREEN LEDs	10,411	967	4,724	439	2,644	246	1,773	165
BLUE LEDs	1,746	162	856	80	488	45	308	29
WHITE LEDs	17,512	1,627	7,438	691	4,013	373	2,803	260
FULL ON	30,601	2,843	12,955	1,204	7,687	714	5,112	475

DIMENSIONAL DIAGRAMS

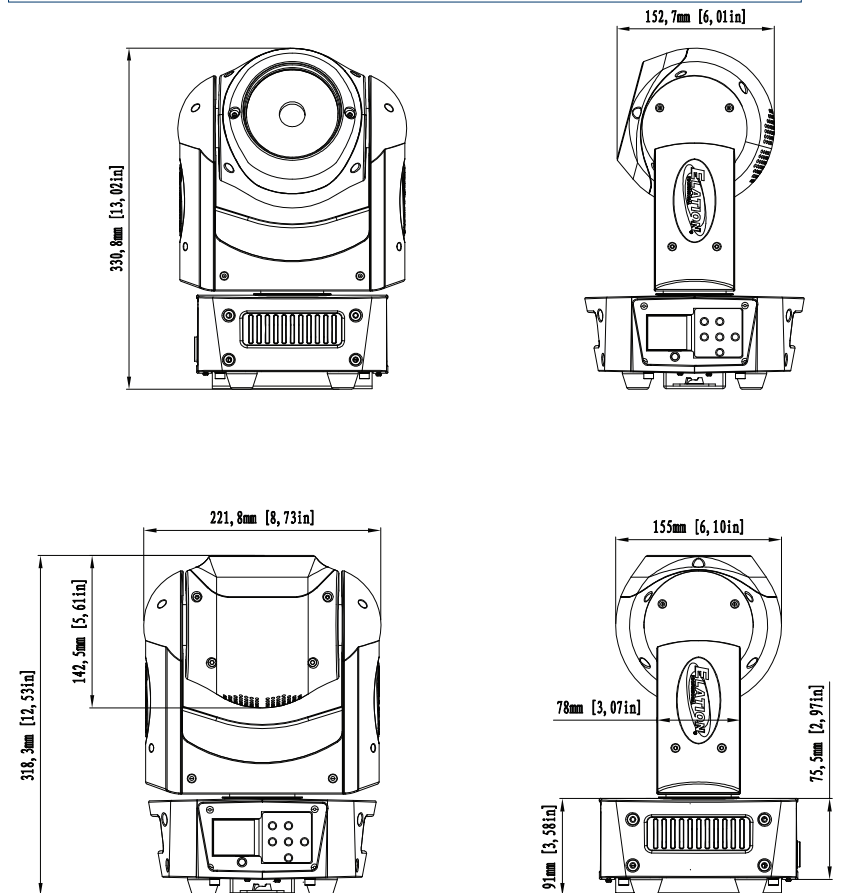

OPTIONAL ACCESSORIES

ORDER CODE	ITEM
TRIGGER CLAMP	Heavy Duty Wrap Around Hook Style Clamp
DRC360I	Road Case For ACL 360i™
PLC3	3' (1m) Power Link Cable
CAT6PRO5	5' (1.5m) CAT6 EtherCON Cable
ACSPDMX5PRO	5 ft. (1.5m) 5pin PRO DMX Cable
	Additional cable lengths available



Specifications are subject to change without notice ©Elation Professional 2/19/16

Elation Professional USA | 6122 S. Eastern Ave. | Los Angeles, CA. 90040
323-582-3322 | 323-832-9142 fax | www.elationlighting.com | info@elationlighting.com

Elation Professional B.V. | Junostraat 2 | 6468 EW Kerkrade, Netherlands
+31 45 546 85 66 | +31 45 546 85 96 fax | www.elationlighting.eu | info@elationlighting.eu