

Spectral distribution

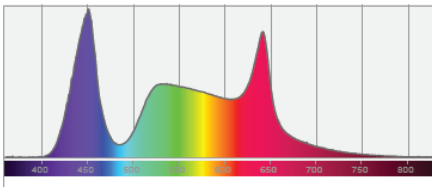

Color coordinates

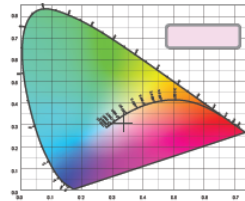

Zoom color point

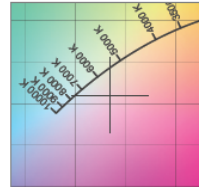

CRI R values

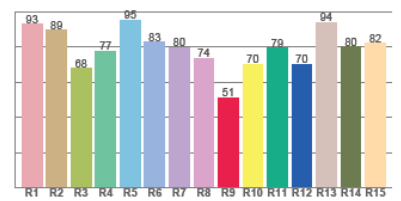

Photometric Test Report

*Due to additional product enhancements, an updated version of this report may be available online. Please check www.elationlighting.com for the latest revision/update of this report.

Light Efficiency:



Output: 2530 lm

Light Quality:

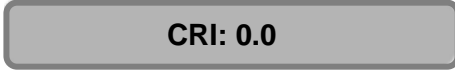

Peak: 10999 cd

Color Temperature:



Power: 140.5 W

PF: 0.97

Beam Angle

28.5°

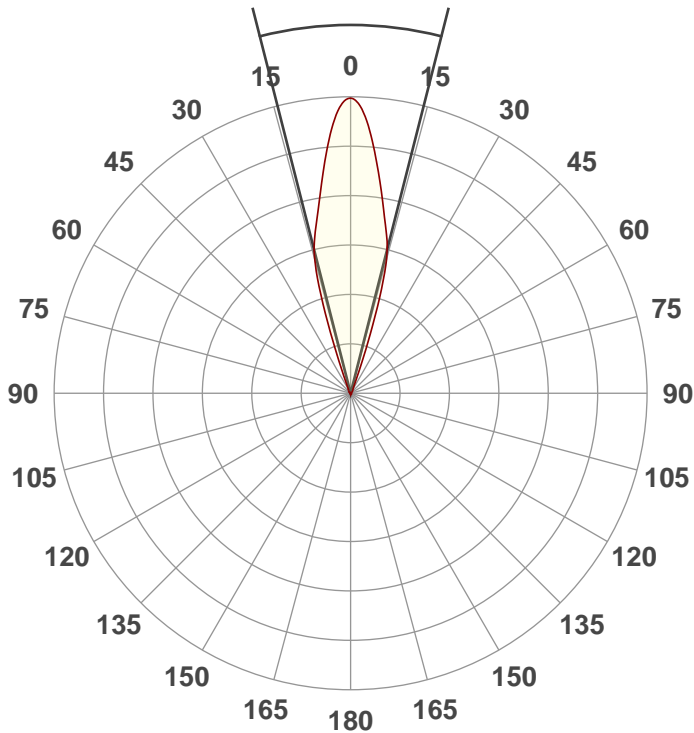

Product Name:

Fuze Par Z120

Test:

Zoom Out Full On

Date:

6/3/2020

Note:



CIE 1931
x: 0.249
y: 0.204

Spectra

Dominant Wavelength: 453nm

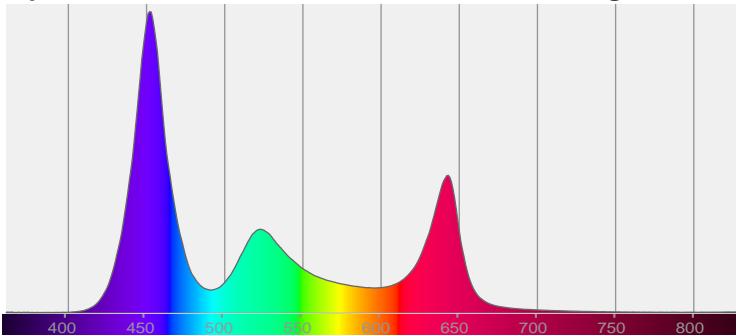

Power

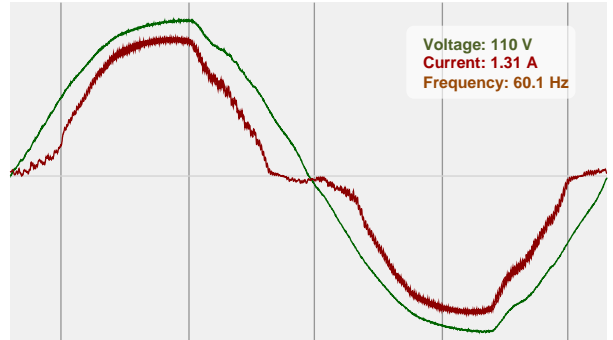

Color Details

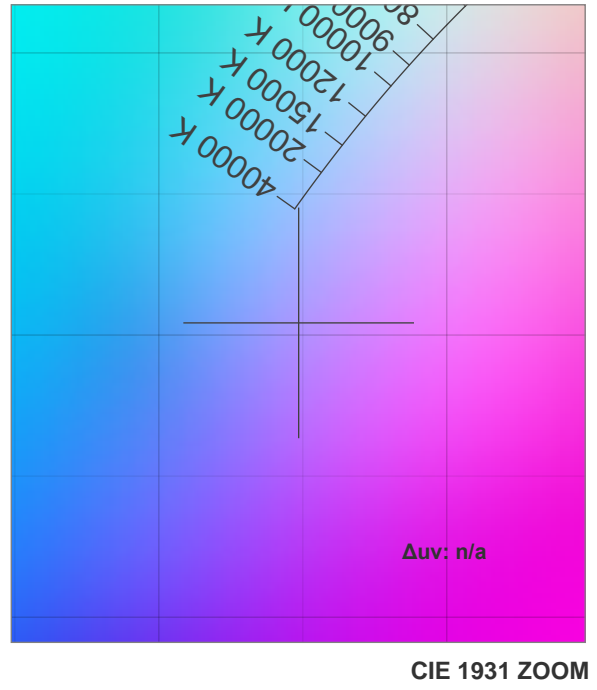
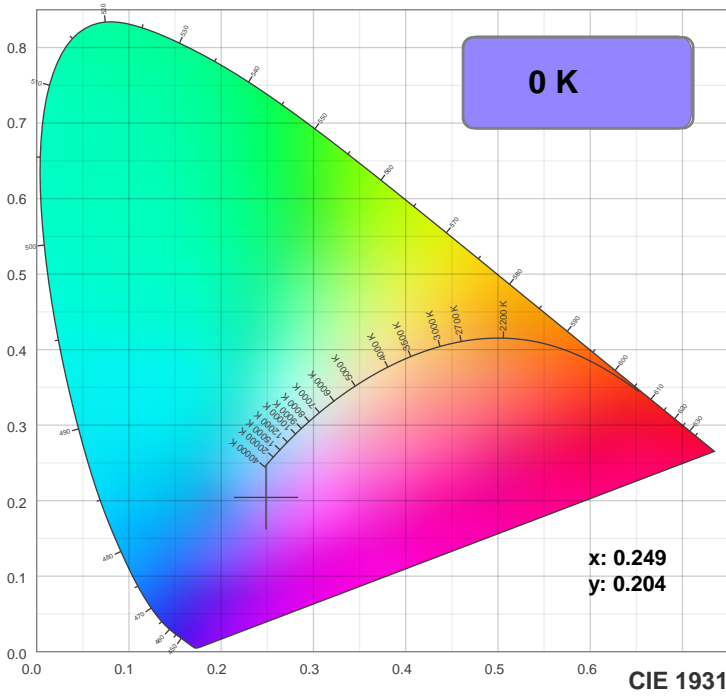

TM30: 0.0

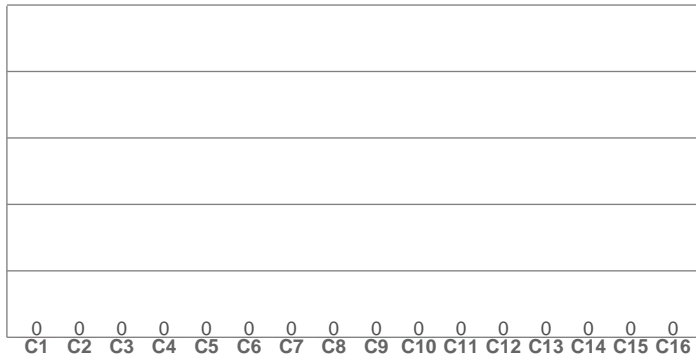

CRI R values, only R1-R8 are used to calculate final CRI value

R1	R2	R3	R4	R5	R6	R7	R8	R9	R10	R11	R12	R13	R14	R15
0.0	0.0	0.0	0.0	0.0	0.0	0.0	0.0	0.0	0.0	0.0	0.0	0.0	0.0	0.0

TM30 C values, 16 binned values out of total of 99 C values

C1	C2	C3	C4	C5	C6	C7	C8	C9	C10	C11	C12	C13	C14	C15	C16
0.0	0.0	0.0	0.0	0.0	0.0	0.0	0.0	0.0	0.0	0.0	0.0	0.0	0.0	0.0	0.0

CQS Q values

Q1	Q2	Q3	Q4	Q5	Q6	Q7	Q8	Q9	Q10	Q11	Q12	Q13	Q14	Q15
0.0	0.0	0.0	0.0	0.0	0.0	0.0	0.0	0.0	0.0	0.0	0.0	0.0	0.0	0.0

CRI: 0.0 (R1-R8)

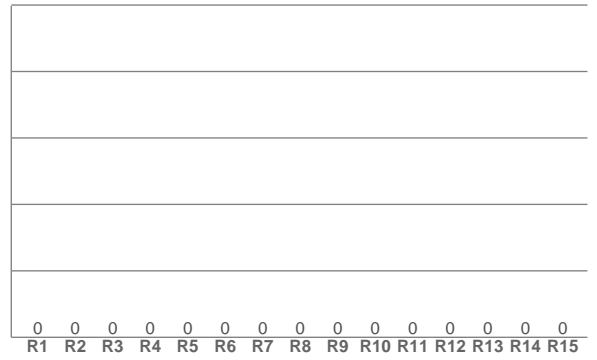

CQS: 0.0

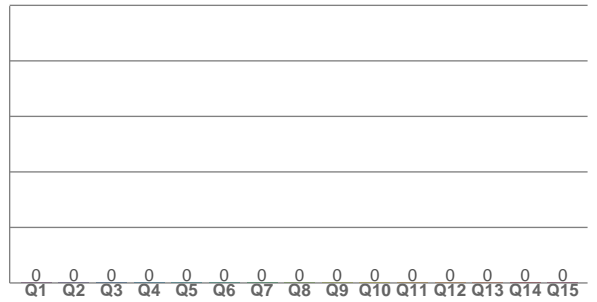

Color Parameters

Color Temperature	Color Rendering Index	Red Component	Color Fidelity	Color Gamut	Color Quality Scale	Color Coordinate CIE 1931	Color Coordinate CIE 1931	Color Coordinate	Color Coordinate	Color Diviation from Black Body
CCT	CRI	CRI R9	TM30 Rf	TM30 Rg	CQS	x	y	u	v	Δuv
0 K	0.0	0.0	0.0	0.0	0.0	0.249	0.204	0.201	0.247	n/a

Beam Details

Distance (meter)
Distance (feet)

1 2 3 4 5
3.3 6.6 9.8 13.1 16.4

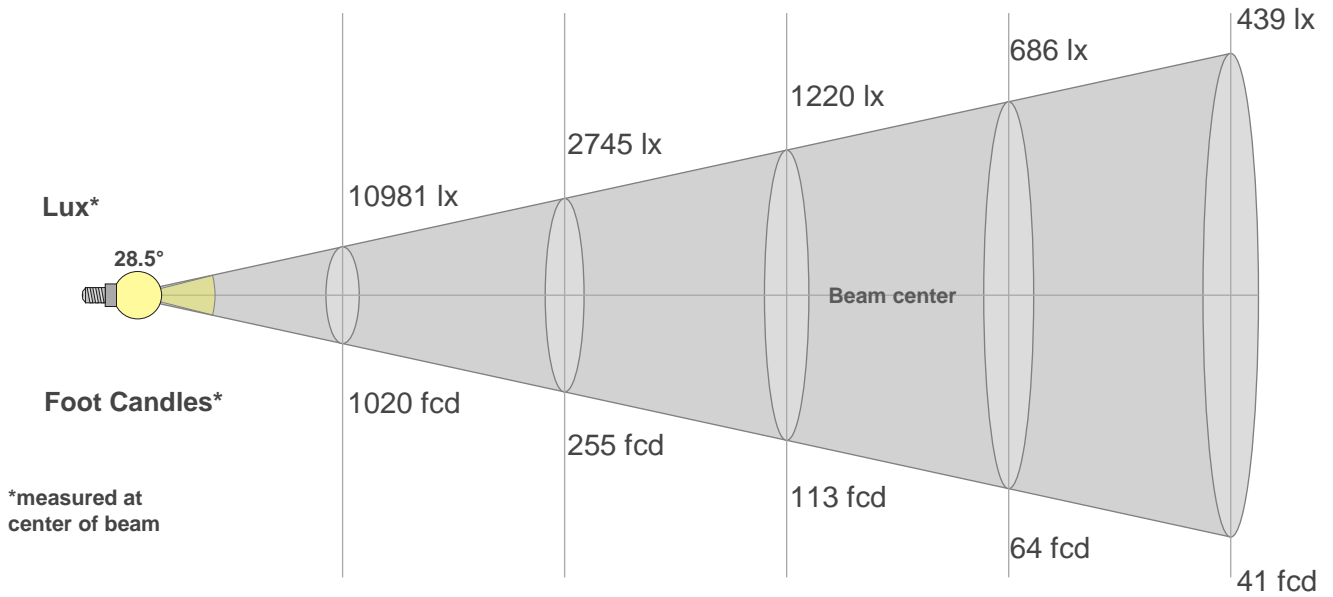

Beam Width (meter)
Beam Width (feet)

0.5 1 1.5 2 2.5
1.7 3.4 5 6.7 8.3

Beam Intensities from 1-20m

m	1	2	3	4	5	6	7	8	9	10	11	12	13	14	15	16	17	18	19	20
ft	3.3	6.6	9.8	13.1	16.4	19.7	23	26.2	29.5	32.8	36.1	39.4	42.7	45.9	49.2	52.5	55.8	59.1	62.3	65.6
lx	10981	2745	1220	686	439	305	224	172	136	110	91	76	65	56	49	43	38	34	30	27
fcd	1020.2	255.1	113.4	63.8	40.8	28.3	20.8	15.9	12.6	10.2	8.4	7.1	6	5.2	4.5	4	3.5	3.1	2.8	2.6

Intensities in 0° C-plane

0°	2°	4°	6°	8°	10°	12°	14°	16°	18°	20°	22°	24°	26°	28°	30°	32°	34°	36°	38°
11.0K	10.7K	9.9K	8.9K	7.9K	7.0K	6.3K	5.6K	4.5K	2.7K	1.3K	0.6K	0.4K	0.3K	0.2K	0.2K	0.1K	0.1K	0.1K	0.1K
100%	97%	90%	81%	72%	63%	57%	51%	41%	25%	11%	5%	3%	2%	2%	1%	1%	1%	1%	1%

Intensities in 90° C-plane

0°	2°	4°	6°	8°	10°	12°	14°	16°	18°	20°	22°	24°	26°	28°	30°	32°	34°	36°	38°
11.0K	10.7K	9.9K	8.9K	7.9K	7.0K	6.3K	5.6K	4.5K	2.7K	1.3K	0.6K	0.4K	0.3K	0.2K	0.2K	0.1K	0.1K	0.1K	0.1K
100%	97%	90%	81%	72%	63%	57%	51%	41%	25%	11%	5%	3%	2%	2%	1%	1%	1%	1%	1%

Intensities in 180° C-plane

0°	2°	4°	6°	8°	10°	12°	14°	16°	18°	20°	22°	24°	26°	28°	30°	32°	34°	36°	38°
11.0K	10.7K	9.9K	8.9K	7.9K	7.1K	6.3K	5.6K	4.5K	2.7K	1.2K	0.6K	0.4K	0.3K	0.2K	0.2K	0.2K	0.2K	0.1K	0.1K
100%	97%	90%	81%	72%	64%	58%	51%	41%	24%	11%	6%	3%	2%	2%	2%	2%	1%	1%	1%

Intensities in 270° C-plane

0°	2°	4°	6°	8°	10°	12°	14°	16°	18°	20°	22°	24°	26°	28°	30°	32°	34°	36°	38°
11.0K	10.7K	9.9K	8.9K	7.9K	7.1K	6.3K	5.6K	4.5K	2.7K	1.2K	0.6K	0.4K	0.3K	0.2K	0.2K	0.2K	0.2K	0.1K	0.1K
100%	97%	90%	81%	72%	64%	58%	51%	41%	24%	11%	6%	3%	2%	2%	2%	2%	1%	1%	1%

Beam Angle 50%	Field Angle 10%	Cutoff Angle 2,5%	Intensity Ratio in 120° Cone	Intensity Ratio in 90° Cone
28.5°	40.7°	51.4°	95.4%	92.7%