



**PALADIN™**  
**BRICK**

Photometric Test Report

©2019 **ELATION PROFESSIONAL** all rights reserved. Information, specifications, diagrams, images, and instructions herein are subject to change without notice. ELATION PROFESSIONAL logo and identifying product names and numbers herein are trademarks of ELATION PROFESSIONAL. Copyright protection claimed includes all forms and matters of copyrightable materials and information now allowed by statutory or judicial law or hereinafter granted. Product names used in this document may be trademarks or registered trademarks of their respective companies and are hereby acknowledged. All non-ELATION brands and product names are trademarks or registered trademarks of their respective companies.

**Elation Professional USA** | 6122 S. Eastern Ave. | Los Angeles, CA. 90040  
323-582-3322 | 323-832-9142 fax | [www.elationlighting.com](http://www.elationlighting.com) | [info@elationlighting.com](mailto:info@elationlighting.com)

**Elation Professional B.V.** | Junostraat 2 | 6468 EW Kerkrade, The Netherlands  
+31 45 546 85 66 | +31 45 546 85 96 fax | [www.elationlighting.eu](http://www.elationlighting.eu) | [info@elationlighting.eu](mailto:info@elationlighting.eu)

**Elation Professional Mexico** | AV Santa Ana 30 | Parque Industrial Lerma, Lerma, Mexico 52000  
+52 (728) 282-7070

# CONTENTS

Testing Process	4
Full On	5
Full On with Frost Filter	6
Red	7
Red with Frost Filter	8
Green	9
Green with Frost Filter	10
Blue	11
Blue with Frost Filter	12
White	13
White with Frost Filter	14
CRI	15

# TESTING PROCESS

## Total Lumen Measurements

Lumens are measured using a Viso Systems Lab Spion and a  $2\pi$  Integrating Sphere. As a goniophotometer, the Viso calculates the field lumens of the fixture by taking multiple measurements across the light beam. The measured lumens of the  $2\pi$  Integrating Sphere tends to be higher than the Viso goniophotometer due to a variety of differences in measurement principles. Therefore, both values are provided in the report.

Many lumens figures provided for entertainment lighting fixtures are only the  $2\pi$  sphere values, some even emphasize the LED engine lumens. All Elation product photometric data is the actual light output from the fixture lens, never a theoretical value based on calculation or using the source lumens as the fixtures output. We advise to always compare total fixture lumens acquired with identical measurement systems when comparing lighting fixtures.

## Test Lab Equipment and Process

Elation operates an optical testing laboratory at its Los Angeles, CA headquarters to provide accurate photometric data for its lighting products. The testing lab is both light and climate-controlled and contains a variety of precise lighting measurement systems. Fixtures are analyzed with the sophisticated [Viso Systems Lab Spion](#) equipment, which measures all light and color parameters by panning the light beam at a precise speed and from different angles through a calibrated, laser aligned light and color sensor. Test data is collected and summarized by the Viso Light Inspector software. This type of measurement system is referred to as a Goniophotometer.

The Viso software calculates all relevant types of measurements, from beam angles, candela to center light intensity at a variety of distances to the latest color quality measurements like TM30 or CQS as well as accurate color temperature. This wealth of data is then processed by an Elation specific template which is included in the photometric test report for various fixture conditions such as zoom angles and color correction filters.

The Viso software also creates IES (Illuminating Engineering Society) files for each test report. IES is an industry standard file format created for the easy electronic transfer of photometric test data, which is widely used by lighting manufacturers for photometric data distribution.

Fixtures are also analyzed using an  $2\pi$  Integrating Sphere. This technique takes the output of the fixture and measures the amount of light inside a sealed perfect sphere. Due to the size of most fixtures they shine into an opening on the side of the sphere. A sensor is mounted behind a glare shield to avoid direct light input and a very short measurement is taken to gather the total lumens within the sphere. Due to different measurement principles, distortion and measurement uncertainties, there is a difference in these results.

Additionally, fixtures are periodically rechecked for accuracy using various hand-held light meters including one or more of the devices listed below. This is done to ensure the test data contained in this report is as accurate as possible.

[Asenstek Lighting Passport](#) | [Konica Minolta T-10](#) | [Sekonic C700](#)

## Total Lumen Output\*

Integrating Sphere **8226 lm**

VISO Lab Spion **8255 lm**

Voltage: 115 V, Current: 3.22 A

Power: 370 W

Efficacy: 22 Lumen/Watt

Measurement Date: 9/18/2019

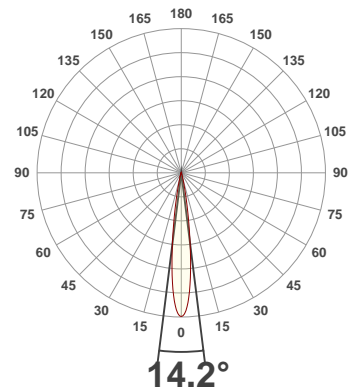
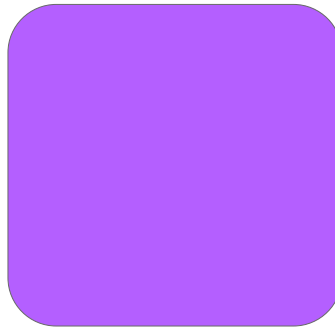

## Spectral distribution

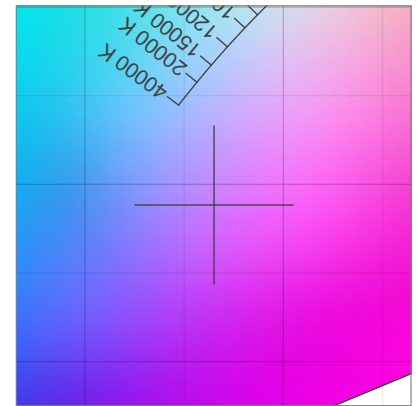
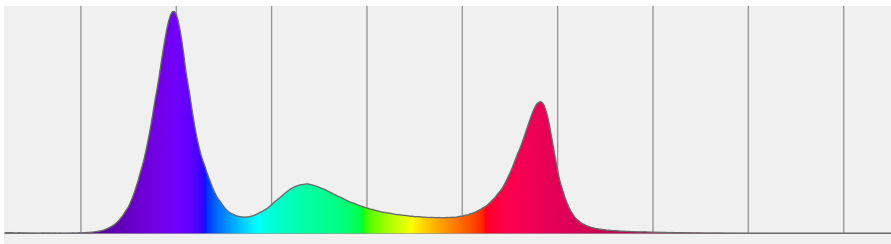

Dominant Wavelength	Color coordinate cie 1931	Color coordinate cie 1931	Color coordinate	Color coordinate
nm	x	y	u	v
360	0.265	0.188	0.224	0.239

## Beam details

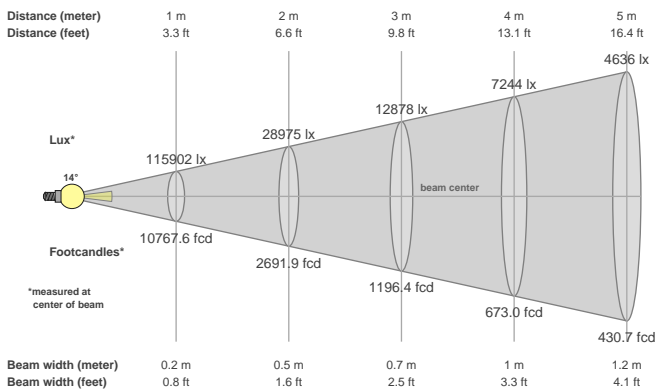

## Beam angles

Beam angle 50%	Field angle 10%	Cutoff angle 2,5%
14.2°	25.2°	34.4°

## Beam intensities

Peak intensity	Int. ratio in 120° cone	Int. ratio in 90° cone
115971 cd	99.9%	99.9%

## Beam Intensities from 1-20m

M	1	2	3	4	5	6	7	8	9	10	11	12	13	14	15	16	17	18	19	20
FT	3.3	6.6	9.8	13.1	16.4	19.7	23	26.2	29.5	32.8	36.1	39.4	42.7	45.9	49.2	52.5	55.8	59.1	62.3	65.6
LX	115902	28975	12878	7244	4636	3219	2365	1811	1431	1159	958	805	686	591	515	453	401	358	321	290
FC	10767.6	2691.9	1196.4	673	430.7	299.1	219.7	168.2	132.9	107.7	89	74.8	63.7	54.9	47.9	42.1	37.3	33.2	29.8	26.9

\*Total Lumen measurements by calibrated Everfine 2π Integrating Sphere and Viso Systems Lab Spion

**Total Lumen Output: 7754 lm**

**Voltage: 116 V, Current: 3.19 A**

**Power: 370 W**

**Efficacy: 21 Lumen/Watt**

**Measurement Date: 9/18/2019**

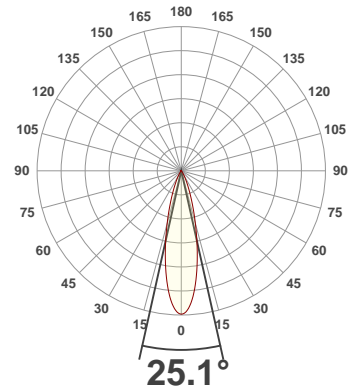
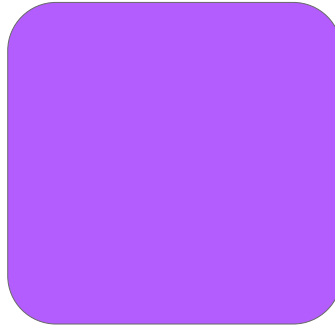

**Spectral distribution**

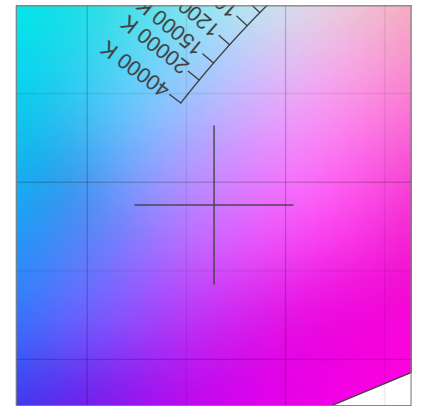
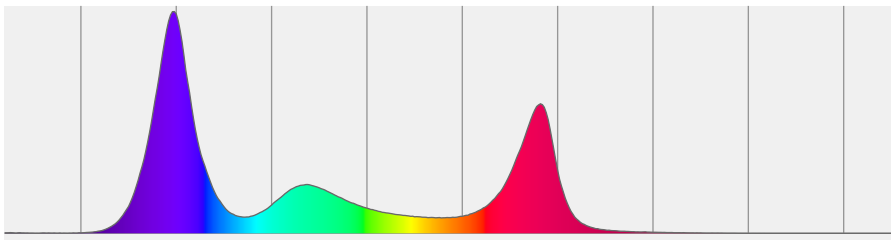

Dominant Wavelength	Color coordinate cie 1931	Color coordinate cie 1931	Color coordinate	Color coordinate
nm	x	y	u	v
360	0.264	0.187	0.224	0.238

**Beam details**

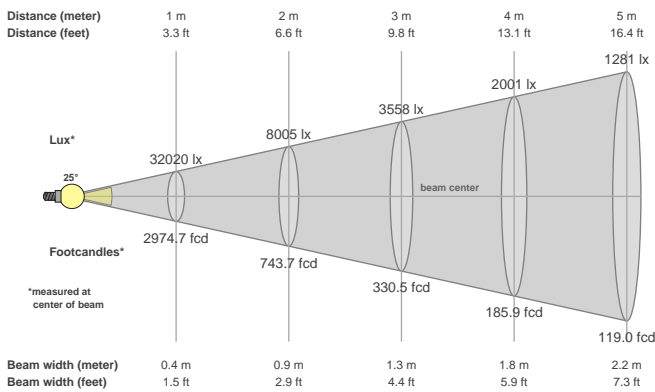

**Beam angles**

Beam angle 50%	Field angle 10%	Cutoff angle 2,5%
25.1°	49.1°	66.1°

**Beam intensities**

Peak intensity	Int. ratio in 120° cone	Int. ratio in 90° cone
32040 cd	99.8%	99.2%

**Beam Intensities from 1-20m**

M	1	2	3	4	5	6	7	8	9	10	11	12	13	14	15	16	17	18	19	20
FT	3.3	6.6	9.8	13.1	16.4	19.7	23	26.2	29.5	32.8	36.1	39.4	42.7	45.9	49.2	52.5	55.8	59.1	62.3	65.6
LX	32020	8005	3558	2001	1281	889	653	500	395	320	265	222	189	163	142	125	111	99	89	80
FC	2974.7	743.7	330.5	185.9	119	82.6	60.7	46.5	36.7	29.7	24.6	20.7	17.6	15.2	13.2	11.6	10.3	9.2	8.2	7.4

**Total Lumen Output: 2464 lm**

**Voltage: 121 V, Current: 0.749 A**

**Power: 87.3 W**

**Efficacy: 28 Lumen/Watt**

**Measurement Date: 9/18/2019**

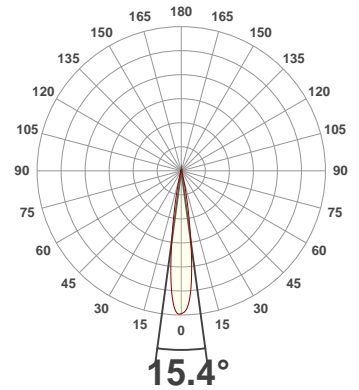
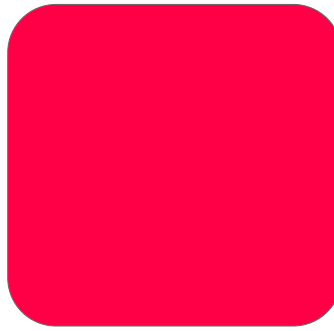

**Spectral distribution**

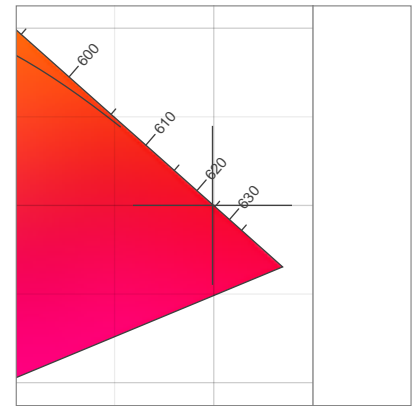
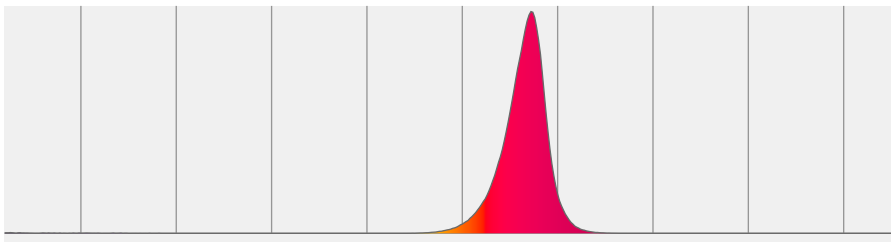

Dominant Wavelength	Color coordinate cie 1931	Color coordinate cie 1931	Color coordinate	Color coordinate
nm	x	y	u	v
625	0.699	0.300	0.538	0.346

**Beam details**

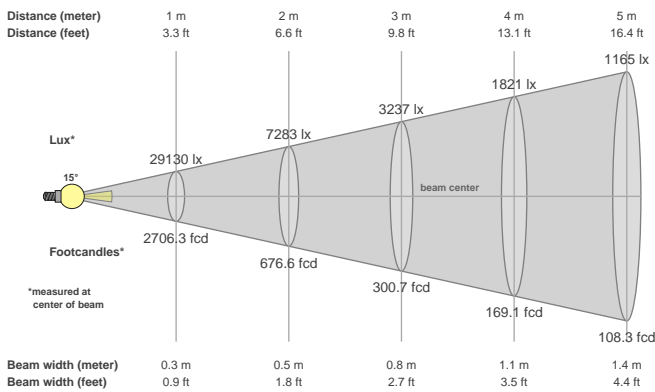

**Beam angles**

Beam angle 50%	Field angle 10%	Cutoff angle 2,5%
15.4°	26.7°	38°

**Beam intensities**

Peak intensity	Int. ratio in 120° cone	Int. ratio in 90° cone
29213 cd	99.9%	99.9%

**Beam Intensities from 1-20m**

M	1	2	3	4	5	6	7	8	9	10	11	12	13	14	15	16	17	18	19	20
FT	3.3	6.6	9.8	13.1	16.4	19.7	23	26.2	29.5	32.8	36.1	39.4	42.7	45.9	49.2	52.5	55.8	59.1	62.3	65.6
LX	29130	7283	3237	1821	1165	809	594	455	360	291	241	202	172	149	129	114	101	90	81	73
FC	2706.3	676.6	300.7	169.1	108.3	75.2	55.2	42.3	33.4	27.1	22.4	18.8	16	13.8	12	10.6	9.4	8.4	7.5	6.8

**Total Lumen Output: 2334 lm**

**Voltage: 119 V, Current: 0.780 A**

**Power: 90.1 W**

**Efficacy: 26 Lumen/Watt**

**Measurement Date: 9/18/2019**

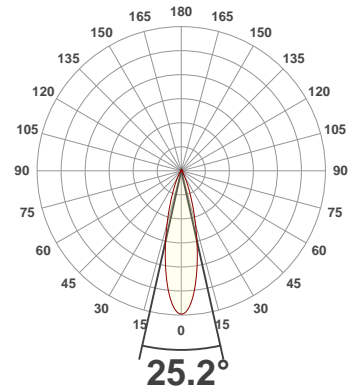
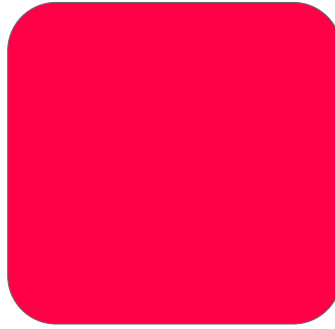

**Spectral distribution**

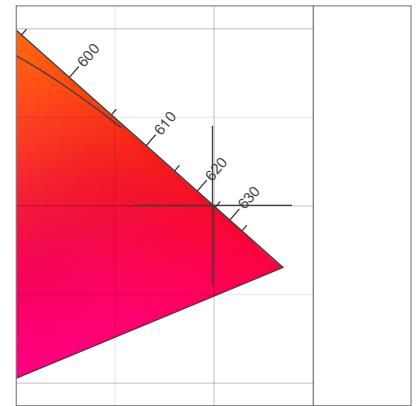
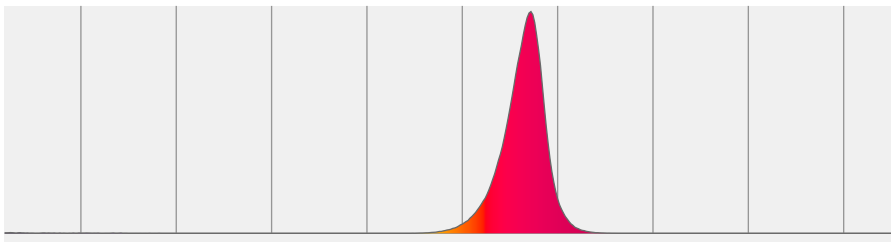

Dominant Wavelength	Color coordinate cie 1931 x	Color coordinate cie 1931 y	Color coordinate u	Color coordinate v
nm	x	y	u	v
624	0.699	0.300	0.537	0.346

**Beam details**

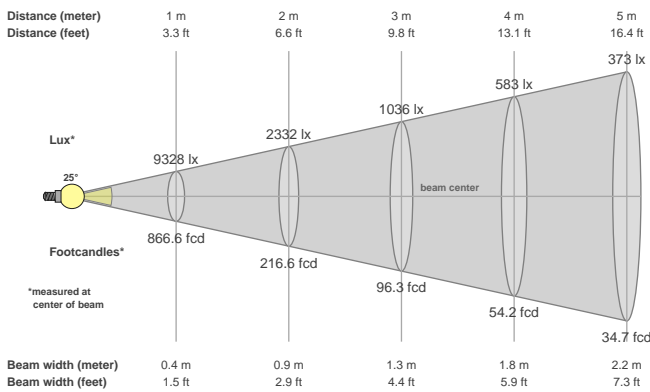

**Beam angles**

Beam angle 50%	Field angle 10%	Cutoff angle 2,5%
25.2°	49.3°	67.9°

**Beam intensities**

Peak intensity	Int. ratio in 120° cone	Int. ratio in 90° cone
9332 cd	99.6%	98.1%

**Beam Intensities from 1-20m**

M	1	2	3	4	5	6	7	8	9	10	11	12	13	14	15	16	17	18	19	20
FT	3.3	6.6	9.8	13.1	16.4	19.7	23	26.2	29.5	32.8	36.1	39.4	42.7	45.9	49.2	52.5	55.8	59.1	62.3	65.6
LX	9328	2332	1036	583	373	259	190	146	115	93	77	65	55	48	41	36	32	29	26	23
FC	866.6	216.6	96.3	54.2	34.7	24.1	17.7	13.5	10.7	8.7	7.2	6	5.1	4.4	3.9	3.4	3	2.7	2.4	2.2



**Total Lumen Output: 3113 lm**

**Voltage: 119 V, Current: 0.890 A**

**Power: 103.4 W**

**Efficacy: 30 Lumen/Watt**

**Measurement Date: 9/18/2019**

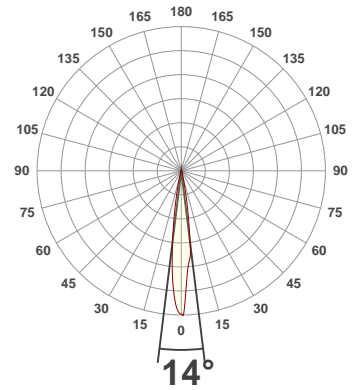
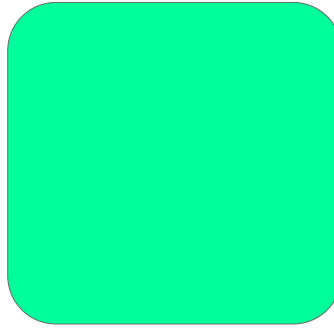

**Spectral distribution**

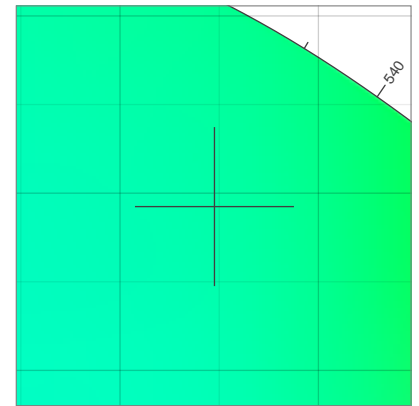
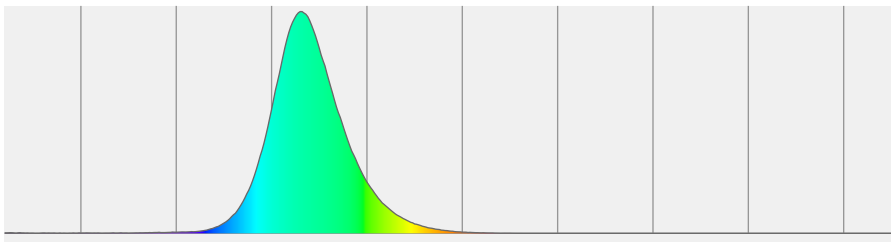

Dominant Wavelength	Color coordinate cie 1931	Color coordinate cie 1931	Color coordinate	Color coordinate
nm	x	y	u	v
521	0.148	0.692	0.054	0.377

**Beam details**

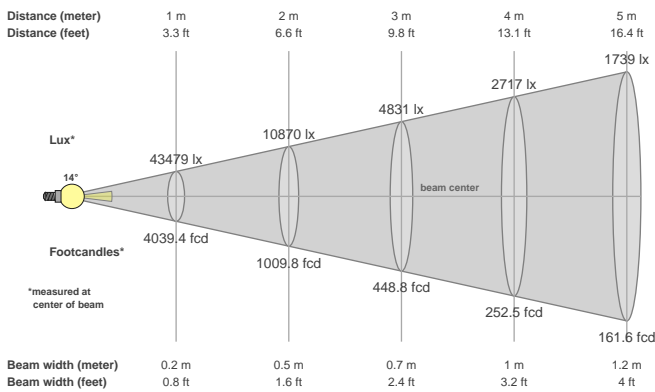

**Beam angles**

Beam angle 50%	Field angle 10%	Cutoff angle 2,5%
14°	25.2°	36°

**Beam intensities**

Peak intensity	Int. ratio in 120° cone	Int. ratio in 90° cone
43526 cd	100.0%	100.0%

**Beam Intensities from 1-20m**

M	1	2	3	4	5	6	7	8	9	10	11	12	13	14	15	16	17	18	19	20
FT	3.3	6.6	9.8	13.1	16.4	19.7	23	26.2	29.5	32.8	36.1	39.4	42.7	45.9	49.2	52.5	55.8	59.1	62.3	65.6
LX	43479	10870	4831	2717	1739	1208	887	679	537	435	359	302	257	222	193	170	150	134	120	109
FC	4039.4	1009.8	448.8	252.5	161.6	112.2	82.4	63.1	49.9	40.4	33.4	28.1	23.9	20.6	18	15.8	14	12.5	11.2	10.1

**Total Lumen Output: 2897 lm**

**Voltage: 119 V, Current: 0.860 A**

**Power: 100.3 W**

**Efficacy: 29 Lumen/Watt**

**Measurement Date: 9/18/2019**

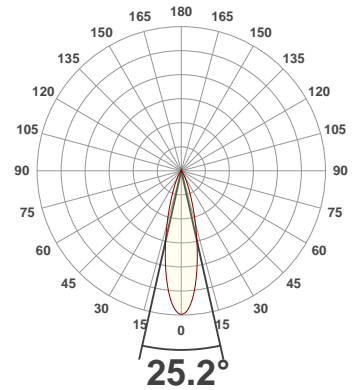
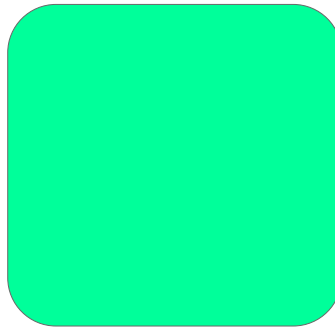

**Spectral distribution**

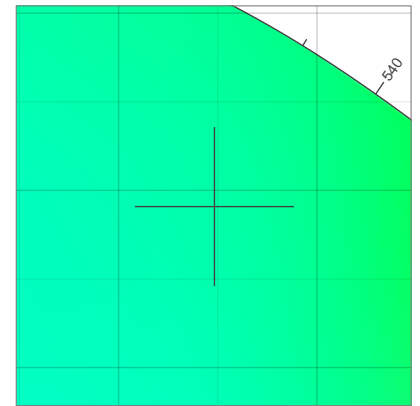
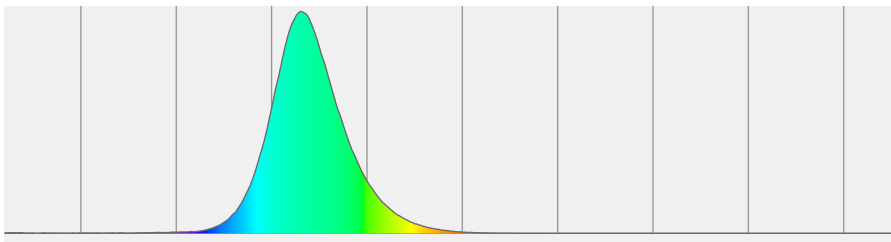

Dominant Wavelength	Color coordinate cie 1931	Color coordinate cie 1931	Color coordinate	Color coordinate
nm	x	y	u	v
521	0.148	0.691	0.054	0.377

**Beam details**

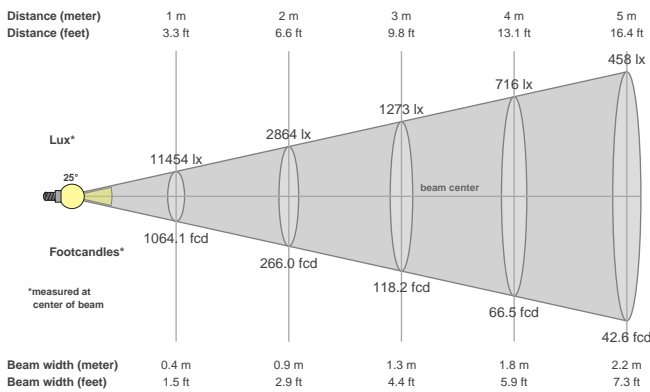

**Beam angles**

Beam angle 50%	Field angle 10%	Cutoff angle 2,5%
25.2°	49.6°	68.8°

**Beam intensities**

Peak intensity	Int. ratio in 120° cone	Int. ratio in 90° cone
11458 cd	99.6%	97.9%

**Beam Intensities from 1-20m**

M	1	2	3	4	5	6	7	8	9	10	11	12	13	14	15	16	17	18	19	20
FT	3.3	6.6	9.8	13.1	16.4	19.7	23	26.2	29.5	32.8	36.1	39.4	42.7	45.9	49.2	52.5	55.8	59.1	62.3	65.6
LX	11454	2864	1273	716	458	318	234	179	141	115	95	80	68	58	51	45	40	35	32	29
FC	1064.1	266	118.2	66.5	42.6	29.6	21.7	16.6	13.1	10.6	8.8	7.4	6.3	5.4	4.7	4.2	3.7	3.3	2.9	2.7

**Total Lumen Output: 689 lm**

**Voltage: 119 V, Current: 0.874 A**

**Power: 101.9 W**

**Efficacy: 7 Lumen/Watt**

**Measurement Date: 9/18/2019**

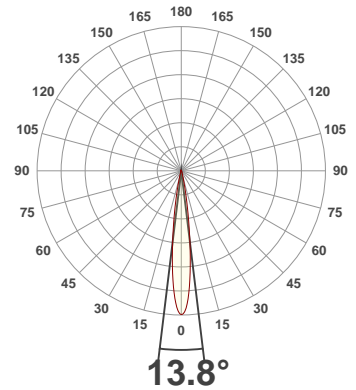
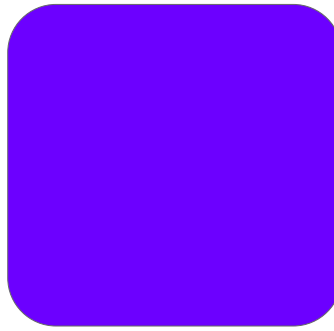

**Spectral distribution**

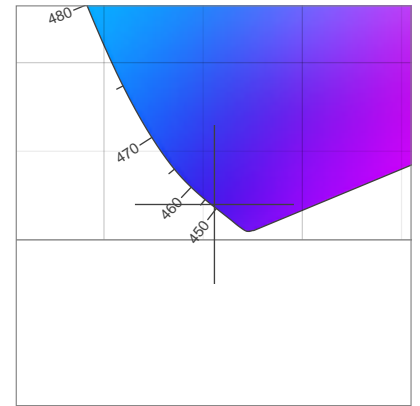
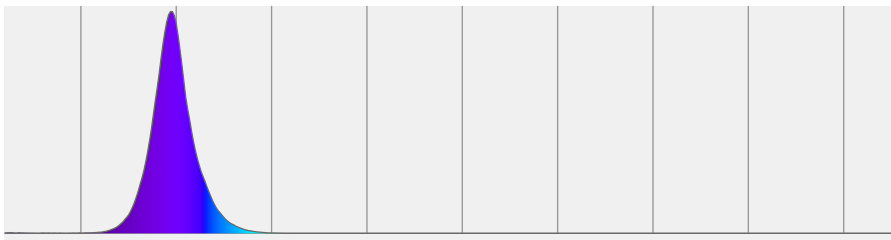

Dominant Wavelength	Color coordinate cie 1931 x	Color coordinate cie 1931 y	Color coordinate u	Color coordinate v
nm	x	y	u	v
451	0.156	0.020	0.213	0.041

**Beam details**

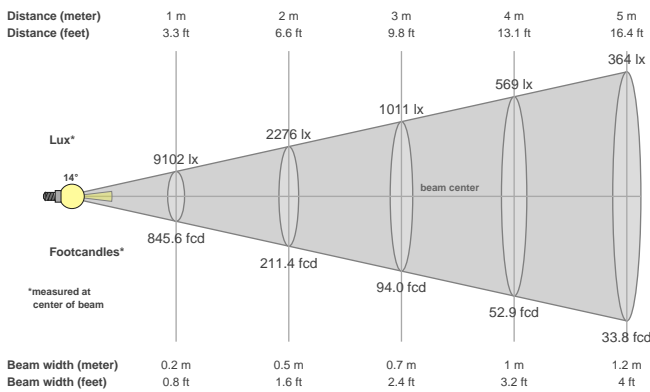

**Beam angles**

Beam angle 50%	Field angle 10%	Cutoff angle 2,5%
13.8°	25.4°	36.5°

**Beam intensities**

Peak intensity	Int. ratio in 120° cone	Int. ratio in 90° cone
9105 cd	99.4%	98.7%

**Beam Intensities from 1-20m**

M	1	2	3	4	5	6	7	8	9	10	11	12	13	14	15	16	17	18	19	20
FT	3.3	6.6	9.8	13.1	16.4	19.7	23	26.2	29.5	32.8	36.1	39.4	42.7	45.9	49.2	52.5	55.8	59.1	62.3	65.6
LX	9102	2276	1011	569	364	253	186	142	112	91	75	63	54	46	40	36	31	28	25	23
FC	845.6	211.4	94	52.9	33.8	23.5	17.3	13.2	10.4	8.5	7	5.9	5	4.3	3.8	3.3	2.9	2.6	2.3	2.1

**Total Lumen Output: 650 lm**

**Voltage: 120 V, Current: 0.874 A**

**Power: 102.3 W**

**Efficacy: 6 Lumen/Watt**

**Measurement Date: 9/18/2019**

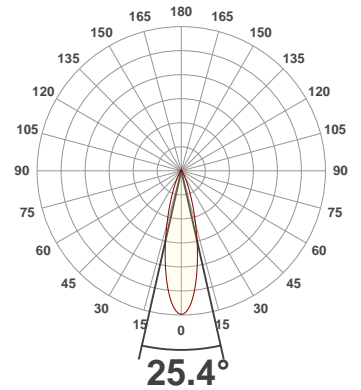
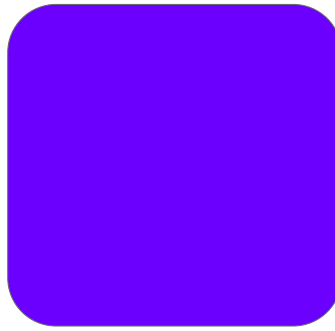

**Spectral distribution**

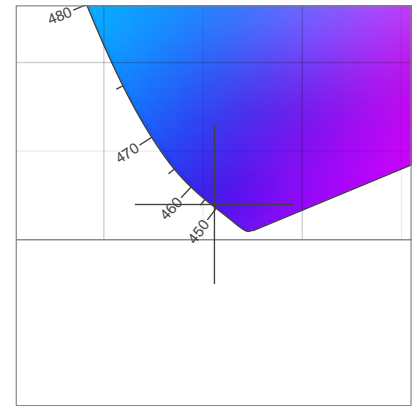
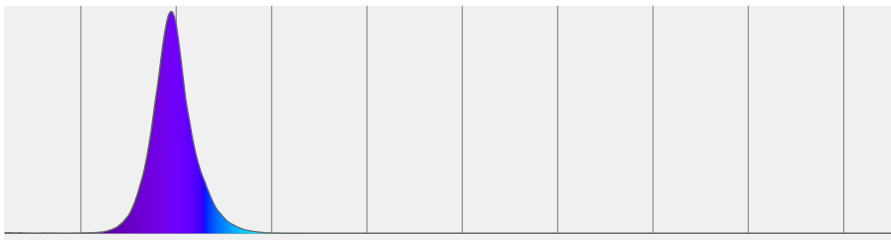

Dominant Wavelength	Color coordinate cie 1931	Color coordinate cie 1931	Color coordinate	Color coordinate
nm	x	y	u	v
451	0.156	0.020	0.213	0.041

**Beam details**

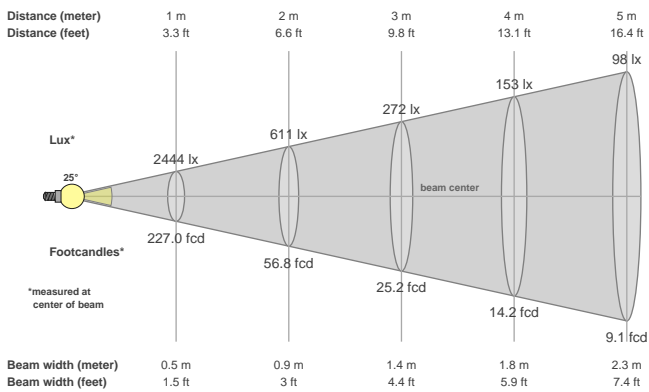

**Beam angles**

Beam angle 50%	Field angle 10%	Cutoff angle 2,5%
25.4°	50.1°	70.2°

**Beam intensities**

Peak intensity	Int. ratio in 120° cone	Int. ratio in 90° cone
2445 cd	97.8%	95.3%

**Beam Intensities from 1-20m**

M	1	2	3	4	5	6	7	8	9	10	11	12	13	14	15	16	17	18	19	20
FT	3.3	6.6	9.8	13.1	16.4	19.7	23	26.2	29.5	32.8	36.1	39.4	42.7	45.9	49.2	52.5	55.8	59.1	62.3	65.6
LX	2444	611	272	153	98	68	50	38	30	24	20	17	14	12	11	10	8	8	7	6
FC	227	56.8	25.2	14.2	9.1	6.3	4.6	3.5	2.8	2.3	1.9	1.6	1.3	1.2	1	0.9	0.8	0.7	0.6	0.6

**Total Lumen Output: 3786 lm**

**Voltage: 119 V, Current: 0.904 A**

**Power: 105.4 W**

**Efficacy: 36 Lumen/Watt**

**Measurement Date: 9/18/2019**

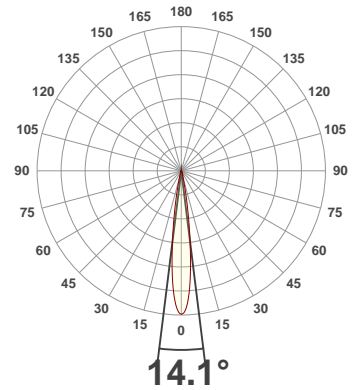
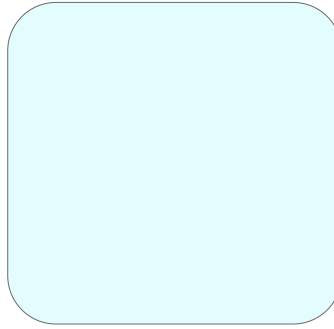

**Spectral distribution**

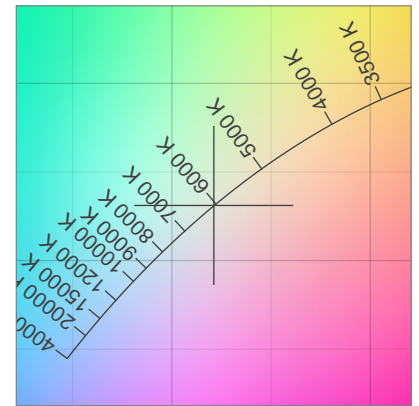
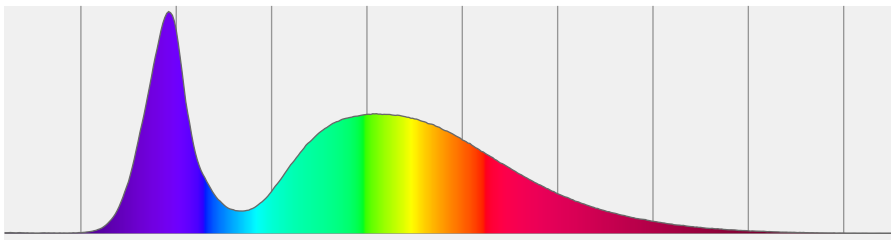

Dominant Wavelength	Color coordinate cie 1931	Color coordinate cie 1931	Color coordinate	Color coordinate
nm	x	y	u	v
594	0.321	0.331	0.203	0.314

**Beam details**

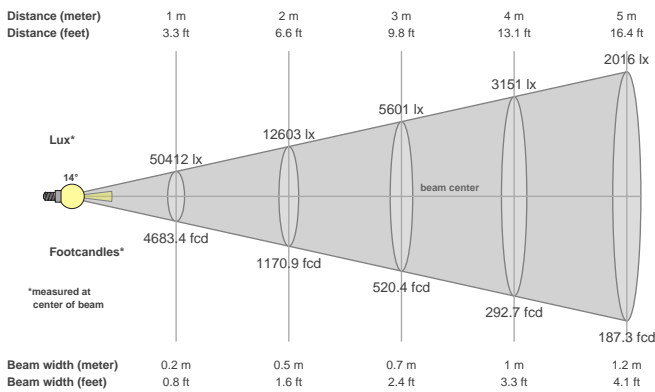

**Beam angles**

Beam angle 50%	Field angle 10%	Cutoff angle 2,5%
14.1°	25.4°	37°

**Beam intensities**

Peak intensity	Int. ratio in 120° cone	Int. ratio in 90° cone
50490 cd	100.0%	99.9%

**Beam Intensities from 1-20m**

M	1	2	3	4	5	6	7	8	9	10	11	12	13	14	15	16	17	18	19	20
FT	3.3	6.6	9.8	13.1	16.4	19.7	23	26.2	29.5	32.8	36.1	39.4	42.7	45.9	49.2	52.5	55.8	59.1	62.3	65.6
LX	50412	12603	5601	3151	2016	1400	1029	788	622	504	417	350	298	257	224	197	174	156	140	126
FC	4683.4	1170.9	520.4	292.7	187.3	130.1	95.6	73.2	57.8	46.8	38.7	32.5	27.7	23.9	20.8	18.3	16.2	14.5	13	11.7

**Total Lumen Output: 3524 lm**

**Voltage: 119 V, Current: 0.880 A**

**Power: 102.1 W**

**Efficacy: 35 Lumen/Watt**

**Measurement Date: 9/18/2019**

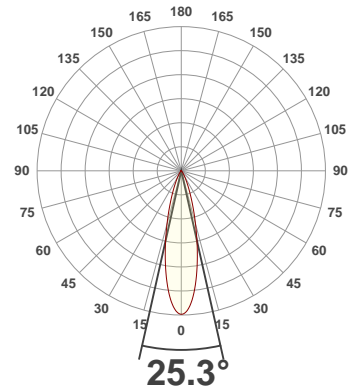
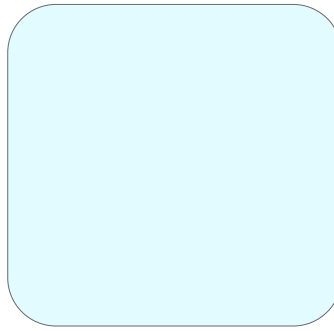

**Spectral distribution**

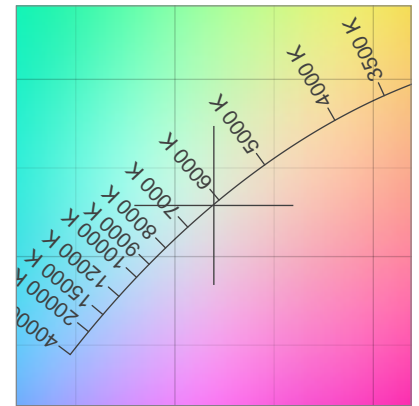
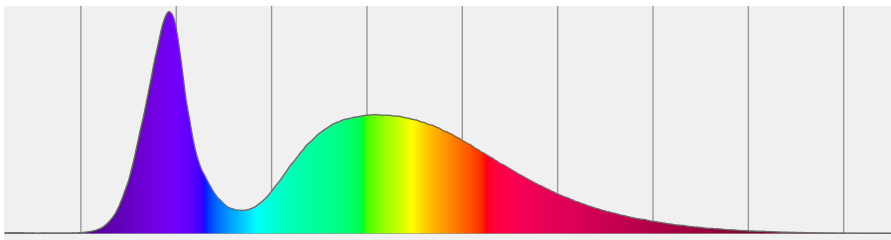

Dominant Wavelength	Color coordinate cie 1931	Color coordinate cie 1931	Color coordinate	Color coordinate
nm	x	y	u	v
615	0.320	0.329	0.203	0.313

**Beam details**

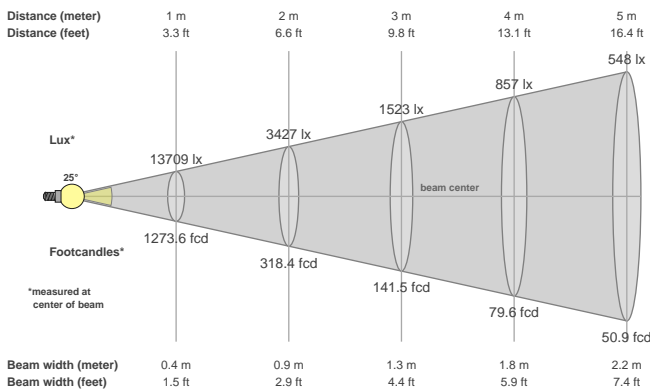

**Beam angles**

Beam angle 50%	Field angle 10%	Cutoff angle 2,5%
25.3°	50°	69.9°

**Beam intensities**

Peak intensity	Int. ratio in 120° cone	Int. ratio in 90° cone
13713 cd	99.6%	97.7%

**Beam Intensities from 1-20m**

M	1	2	3	4	5	6	7	8	9	10	11	12	13	14	15	16	17	18	19	20
FT	3.3	6.6	9.8	13.1	16.4	19.7	23	26.2	29.5	32.8	36.1	39.4	42.7	45.9	49.2	52.5	55.8	59.1	62.3	65.6
LX	13709	3427	1523	857	548	381	280	214	169	137	113	95	81	70	61	54	47	42	38	34
FC	1273.6	318.4	141.5	79.6	50.9	35.4	26	19.9	15.7	12.7	10.5	8.8	7.5	6.5	5.7	5	4.4	3.9	3.5	3.2

**Total Lumen Output: 6239 lm**

**Color Temperature: 5367 K**

**CRI: 83.6**

**TLCI: 68**

**TM30: 86.6**

**CQS: 84.0**

**Measurement Date: 9/18/2019**

**Voltage: 116 V, Current: 1.72 A**

**Power: 196.2 W**

**Efficacy: 32 Lumen/Watt**

**High CRI Values:**

R @ 33%

G @ 73%

W @ 100%

**Spectral distribution**  
Dominant Wavelength 565

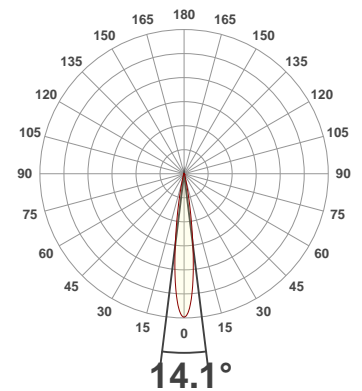
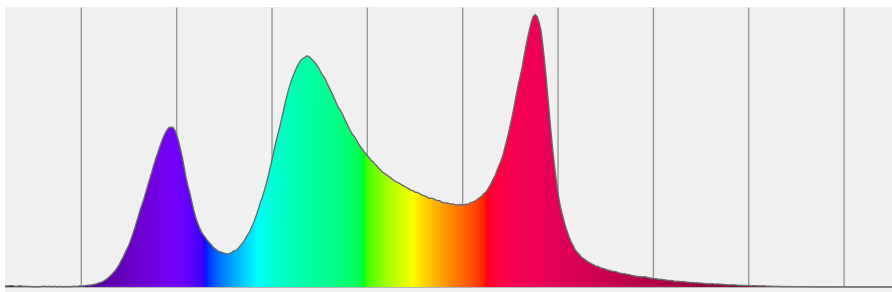

**Beam details**

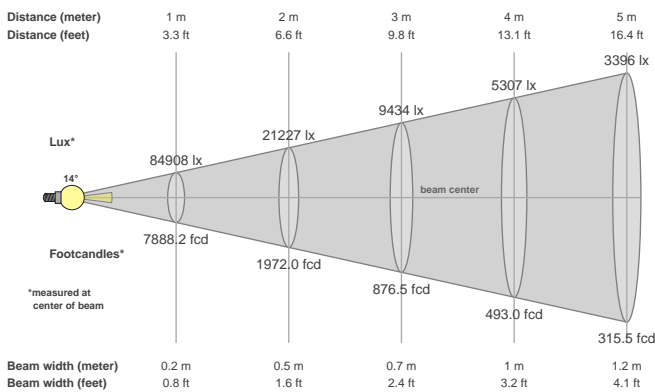

**Beam angles**

Beam angle 50%	Field angle 10%	Cutoff angle 2,5%
<b>14.1°</b>	<b>25.4°</b>	<b>36.2°</b>

**Beam intensities**

Peak intensity	Int. ratio in 120° cone	Int. ratio in 90° cone
<b>85014 cd</b>	<b>100.0%</b>	<b>100.0%</b>

**Beam Intensities from 1-20m**

M	1	2	3	4	5	6	7	8	9	10	11	12	13	14	15	16	17	18	19	20
FT	3.3	6.6	9.8	13.1	16.4	19.7	23	26.2	29.5	32.8	36.1	39.4	42.7	45.9	49.2	52.5	55.8	59.1	62.3	65.6
LX	84908	21227	9434	5307	3396	2359	1733	1327	1048	849	702	590	502	433	377	332	294	262	235	212
FC	7888.2	1972	876.5	493	315.5	219.1	161	123.3	97.4	78.9	65.2	54.8	46.7	40.2	35.1	30.8	27.3	24.3	21.9	19.7

### Color Details

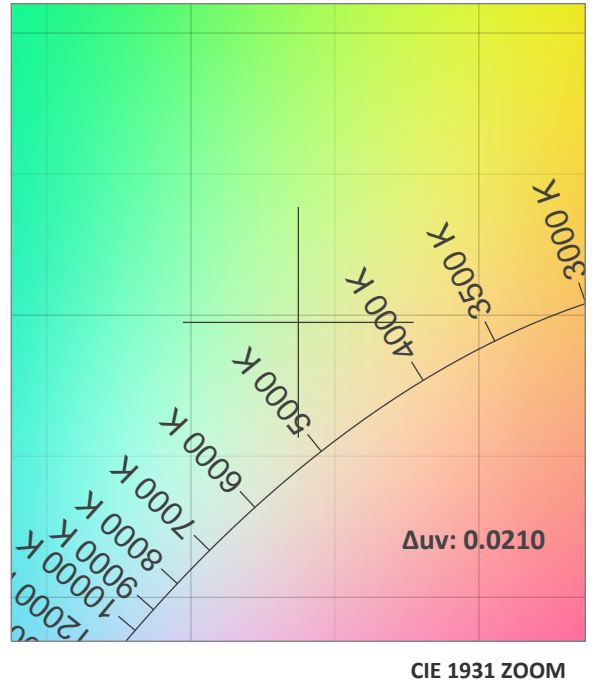
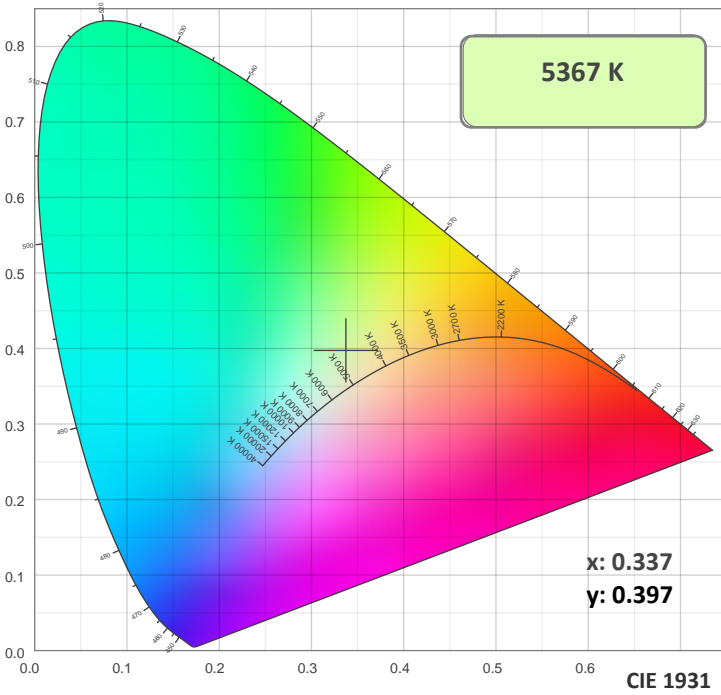

TM30: 86.6

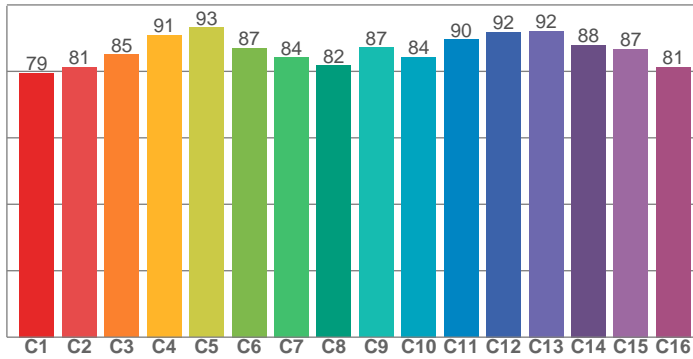

CRI: 83.6 (R1-R8)

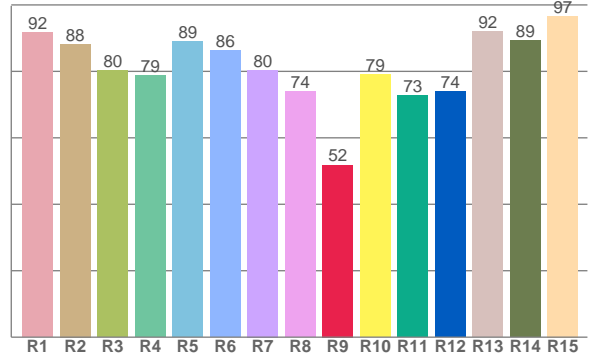

CRI R values, only R1-R8 are used to calculate final CRI value

R1	R2	R3	R4	R5	R6	R7	R8	R9	R10	R11	R12	R13	R14	R15
91.8	88.2	80.3	78.7	89.0	86.3	80.4	73.9	51.9	79.1	72.7	73.9	92.0	89.4	96.7

TM30 C Values, 16 binned values out of total of 99 C values

C1	C2	C3	C4	C5	C6	C7	C8	C9	C10	C11	C12	C13	C14	C15	C16
79.5	81.4	85.1	90.9	93.2	87.1	84.3	81.8	87.2	84.3	89.6	91.9	92.2	88.0	86.7	81.3

CQS Q Values

Q1	Q2	Q3	Q4	Q5	Q6	Q7	Q8	Q9	Q10	Q11	Q12	Q13	Q14	Q15
93.7	98.8	92.6	81.3	77.6	80.4	92.9	89.2	90.8	85.8	75.6	73.0	73.8	93.6	97.3

CQS: 84.0

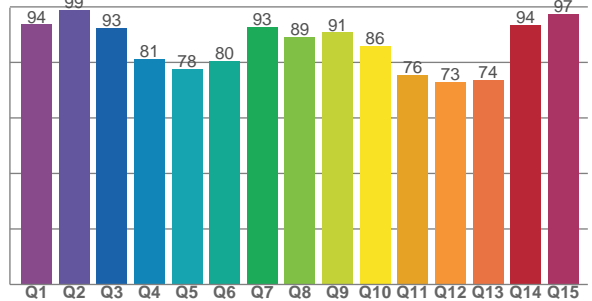

### Color Parameters

Color Temperature	Color Rendering Index	Red Component	Color Fidelity	Color Gamut	Color Quality Scale	Color Coordinate CIE 1931	Color Coordinate CIE 1931	Color Coordinate	Color Coordinate	Color Diviation from Black
CCT	CRI	CRI R9	TM30 Rf	TM30 Rg	CQS	x	y	u	v	Δuv
5367 K	83.6	51.9	86.6	105.0	84.0	0.337	0.397	0.190	0.336	0.0210



TM30 Details

**Rf 86.6**  
Fidelity Index Rf

**Rg 105.0**  
Gamut Index Rg

Hue Bin	R <sub>f</sub>	Graphic shifts (%)	
		Chroma	Hue
1	79	8%	-5%
2	81	4%	-9%
3	85	1%	-6%
4	91	-2%	-2%
5	93	-1%	2%
6	87	6%	4%
7	84	7%	-2%
8	82	3%	-8%
9	87	0%	-9%
10	84	-4%	-6%
11	90	-3%	3%
12	92	-2%	4%
13	92	1%	5%
14	88	4%	5%
15	87	8%	5%
16	81	11%	-4%

