



# PROTEUS™ RAYZOR 760

## Photometric Test Report

©2019 **ELATION PROFESSIONAL** all rights reserved. Information, specifications, diagrams, images, and instructions herein are subject to change without notice. ELATION PROFESSIONAL logo and identifying product names and numbers herein are trademarks of ELATION PROFESSIONAL. Copyright protection claimed includes all forms and matters of copyrightable materials and information now allowed by statutory or judicial law or hereinafter granted. Product names used in this document may be trademarks or registered trademarks of their respective companies and are hereby acknowledged. All non-ELATION brands and product names are trademarks or registered trademarks of their respective companies.

**Elation Professional USA** | 6122 S. Eastern Ave. | Los Angeles, CA. 90040  
323-582-3322 | 323-832-9142 fax | [www.elationlighting.com](http://www.elationlighting.com) | [info@elationlighting.com](mailto:info@elationlighting.com)

**Elation Professional B.V.** | Junostraat 2 | 6468 EW Kerkrade, The Netherlands  
+31 45 546 85 66 | +31 45 546 85 96 fax | [www.elationlighting.eu](http://www.elationlighting.eu) | [info@elationlighting.eu](mailto:info@elationlighting.eu)

**Elation Professional Mexico** | AV Santa Ana 30 | Parque Industrial Lerma, Lerma, Mexico 52000  
+52 (728) 282-7070

# CONTENTS

Testing Process	4
Zoom In	5
Zoom 50%	10
Zoom Out	15
CTO	20

# TESTING PROCESS

## Total Lumen Measurements

Lumens are measured using a Viso Systems Lab Spion and a  $2\pi$  Integrating Sphere. As a goniophotometer, the Viso calculates the field lumens of the fixture by taking multiple measurements across the light beam. The measured lumens of the  $2\pi$  Integrating Sphere tends to be higher than the Viso goniophotometer due to a variety of differences in measurement principles. Therefore, both values are provided in the report.

Many lumens figures provided for entertainment lighting fixtures are only the  $2\pi$  sphere values, some even emphasize the LED engine lumens. All Elation product photometric data is the actual light output from the fixture lens, never a theoretical value based on calculation or using the source lumens as the fixtures output. We advise to always compare total fixture lumens acquired with identical measurement systems when comparing lighting fixtures.

## Test Lab Equipment and Process

Elation operates an optical testing laboratory at its Los Angeles, CA headquarters to provide accurate photometric data for its lighting products. The testing lab is both light and climate-controlled and contains a variety of precise lighting measurement systems. Fixtures are analyzed with the sophisticated [Viso Systems Lab Spion](#) equipment, which measures all light and color parameters by panning the light beam at a precise speed and from different angles through a calibrated, laser aligned light and color sensor. Test data is collected and summarized by the Viso Light Inspector software. This type of measurement system is referred to as a Goniophotometer.

The Viso software calculates all relevant types of measurements, from beam angles, candela to center light intensity at a variety of distances to the latest color quality measurements like TM30 or CQS as well as accurate color temperature. This wealth of data is then processed by an Elation specific template which is included in the photometric test report for various fixture conditions such as zoom angles and color correction filters.

The Viso software also creates IES (Illuminating Engineering Society) files for each test report. IES is an industry standard file format created for the easy electronic transfer of photometric test data, which is widely used by lighting manufacturers for photometric data distribution.

Fixtures are also analyzed using an  $2\pi$  Integrating Sphere. This technique takes the output of the fixture and measures the amount of light inside a sealed perfect sphere. Due to the size of most fixtures they shine into an opening on the side of the sphere. A sensor is mounted behind a glare shield to avoid direct light input and a very short measurement is taken to gather the total lumens within the sphere. Due to different measurement principles, distortion and measurement uncertainties, there is a difference in these results.

Additionally, fixtures are periodically rechecked for accuracy using various hand-held light meters including one or more of the devices listed below. This is done to ensure the test data contained in this report is as accurate as possible.

[Asenstek Lighting Passport](#) | [Konica Minolta T-10](#) | [Sekonic C700](#)

# Photometric Report

## Total Lumen Output\*

Integrating Sphere      4500 lm

VISO Lab Spion          3188 lm

Beam Angle 50%	Field Angle 10%	Cutoff Angle 2.5%
5.4°	8.1°	9.4°

Color Temperature: 0 K

CRI: 0.0

TLCI: n/a

TM30: 0.0

CQS: 0.0

Voltage: 115 V, Current: 3.25 A

Power: 375 W

Efficacy: 9 Lumen/Watt

Measurement Date: 8/2/2019

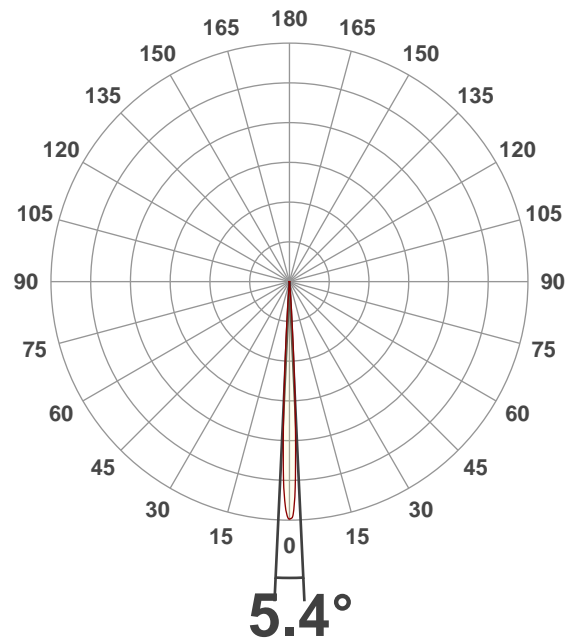

## Spectral Distribution

Dominant Wavelength 458 nm

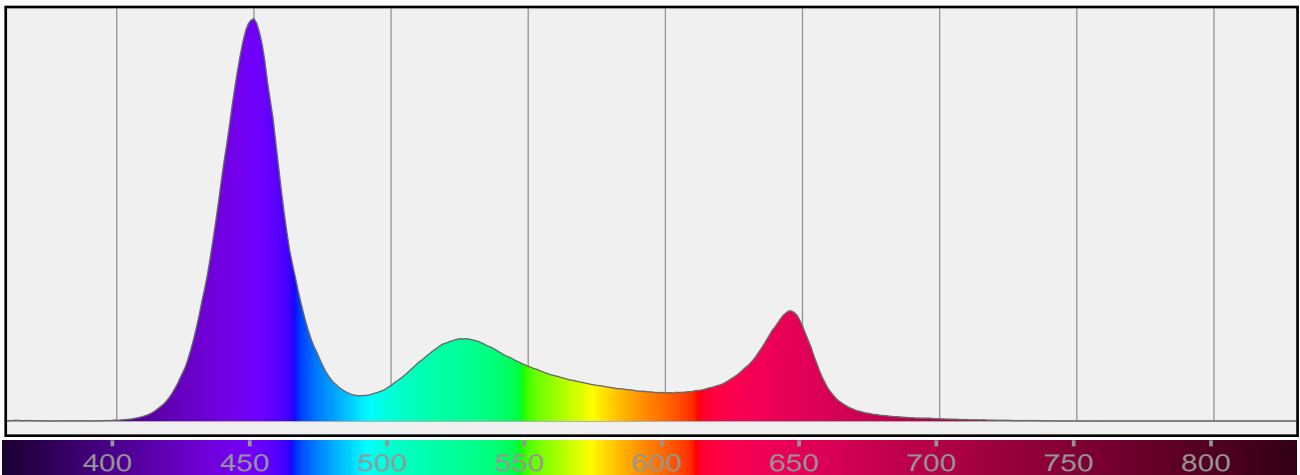

\*Total Lumen measurements by calibrated Everfine 2π Integrating Sphere and Viso Systems Lab Spion

### Beam Details

Beam Angle 50%	Field Angle 10%	Cutoff Angle 2,5%
5.4°	8.1°	9.4°

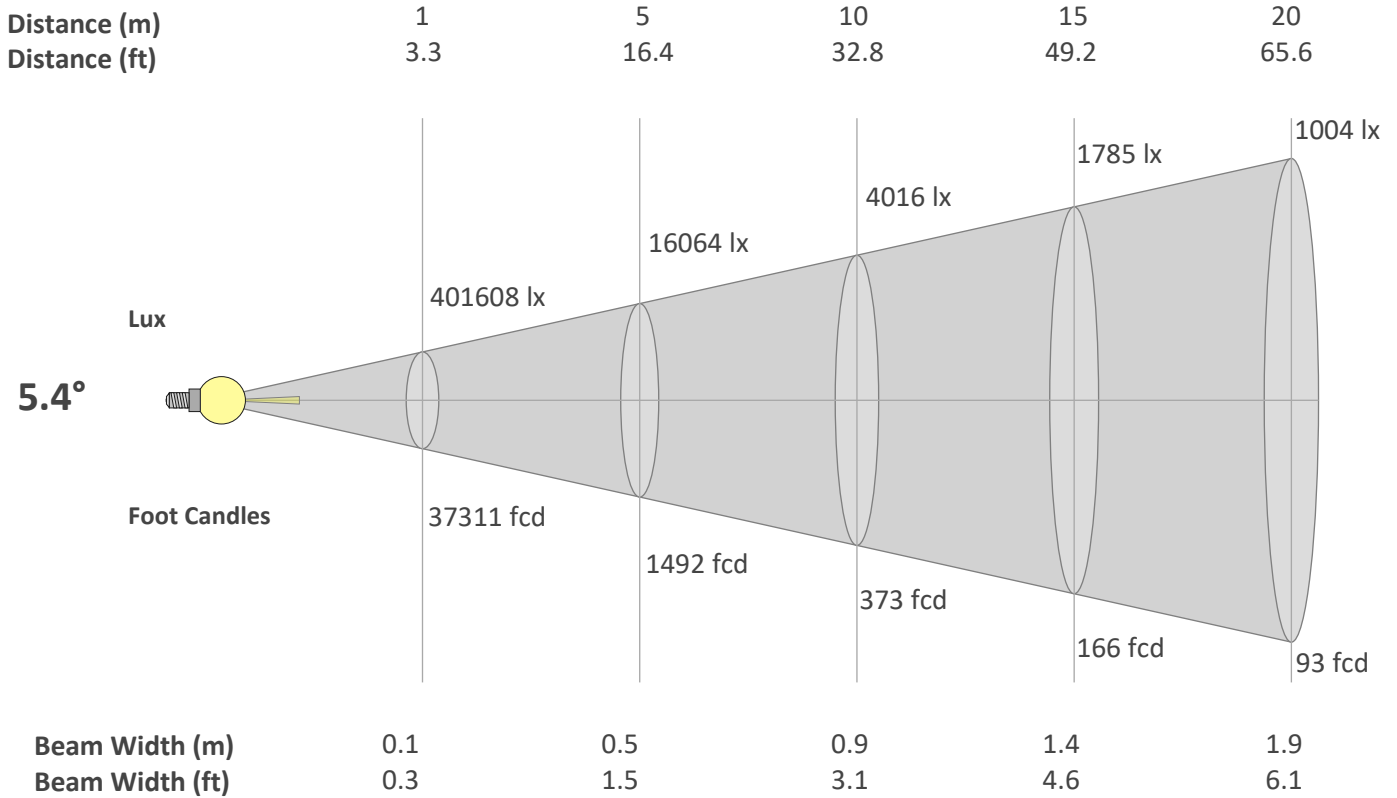

#### Beam Intensities from 1-20m

M	1	2	3	4	5	6	7	8	9	10	11	12	13	14	15	16	17	18	19	20
FT	3.3	6.6	9.8	13.1	16.4	19.7	23	26.2	29.5	32.8	36.1	39.4	42.7	45.9	49.2	52.5	55.8	59.1	62.3	65.6
LX	401608	100402	44623	25101	16064	11156	8196	6275	4958	4016	3319	2789	2376	2049	1785	1569	1390	1240	1112	1004
FC	37310.6	9327.7	4145.6	2331.9	1492.4	1036.4	761.4	583	460.6	373.1	308.4	259.1	220.8	190.4	165.8	145.7	129.1	115.2	103.4	93.3

#### Linear Distribution

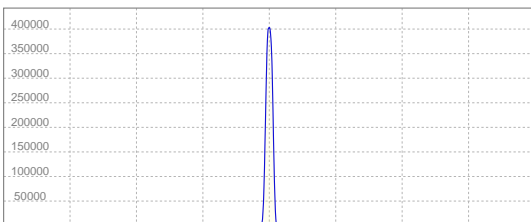

**Peak Candela**  
**402433 cd**

**Calculate Center Beam Intensities**

$lux = 402433 / distance(m)^2$

$fc = 402433 / distance(ft)^2$

### Color Details

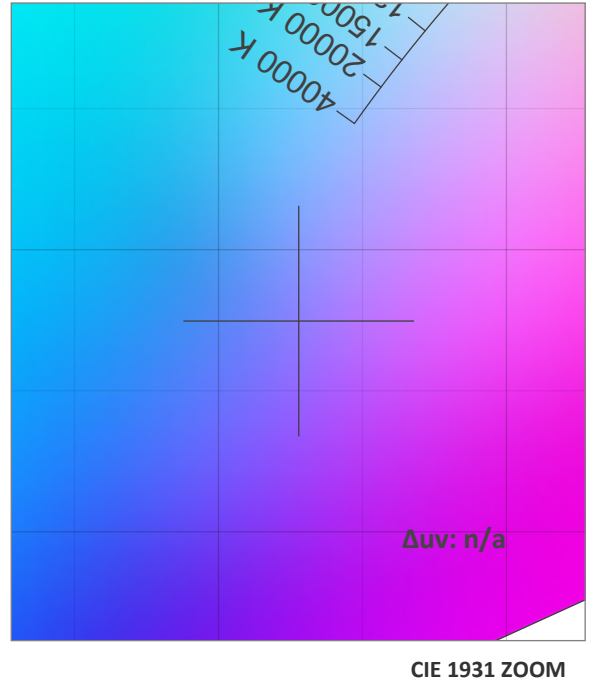
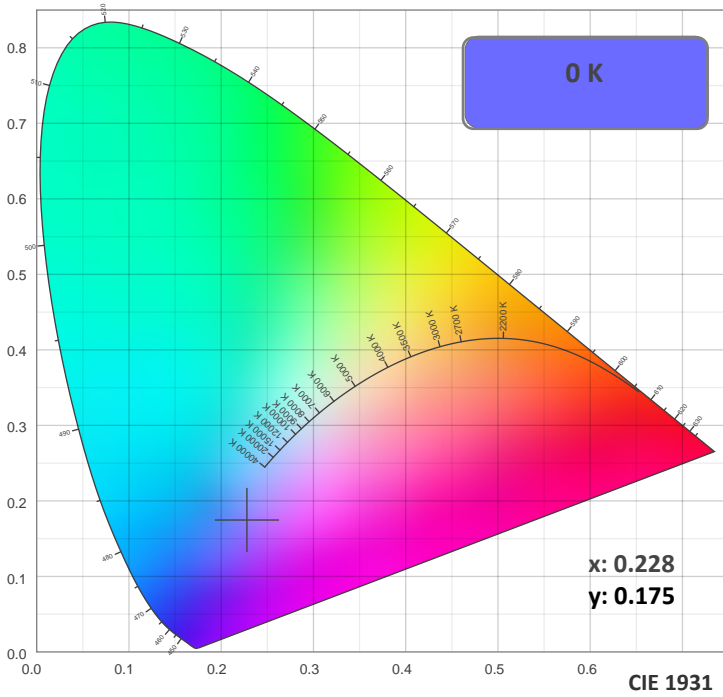

**TM30: 0.0**

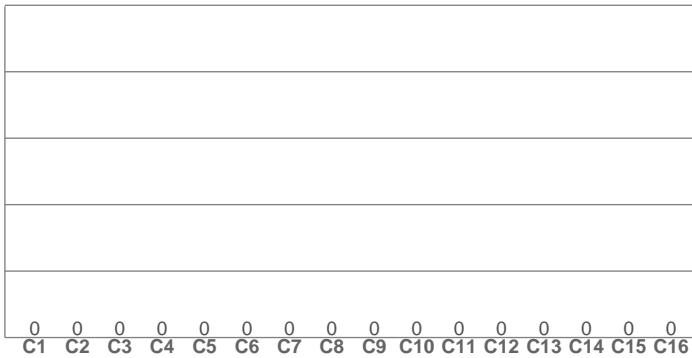

**CRI R values, only R1-R8 are used to calculate final CRI value**

R1	R2	R3	R4	R5	R6	R7	R8	R9	R10	R11	R12	R13	R14	R15
0.0	0.0	0.0	0.0	0.0	0.0	0.0	0.0	0.0	0.0	0.0	0.0	0.0	0.0	0.0

**TM30 C Values, 16 binned values out of total of 99 C values**

C1	C2	C3	C4	C5	C6	C7	C8	C9	C10	C11	C12	C13	C14	C15	C16
0.0	0.0	0.0	0.0	0.0	0.0	0.0	0.0	0.0	0.0	0.0	0.0	0.0	0.0	0.0	0.0

**CQS Q Values**

Q1	Q2	Q3	Q4	Q5	Q6	Q7	Q8	Q9	Q10	Q11	Q12	Q13	Q14	Q15
0.0	0.0	0.0	0.0	0.0	0.0	0.0	0.0	0.0	0.0	0.0	0.0	0.0	0.0	0.0

**CRI: 0.0 (R1-R8)**

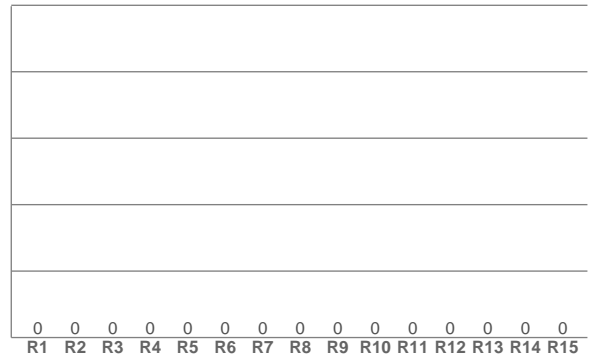

**CQS: 0.0**

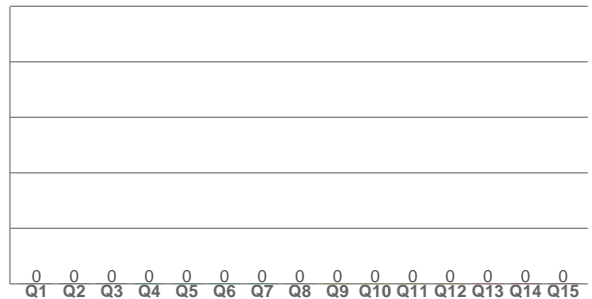

### Color Parameters

Color Temperature	Color Rendering Index	Red Component	Color Fidelity	Color Gamut	Color Quality Scale	Color Coordinate CIE 1931	Color Coordinate CIE 1931	Color Coordinate	Color Coordinate	Color Deviation from Black
CCT	CRI	CRI R9	TM30 Rf	TM30 Rg	CQS	x	y	u	v	Δuv
0 K	0.0	0.0	0.0	0.0	0.0	0.228	0.175	0.196	0.226	n/a

TM30 Details

**Rf 0.0**  
Fidelity Index Rf

**Rg 0.0**  
Gamut Index Rg

Hue Bin	R <sub>f</sub>	Graphic shifts (%)	
		Chroma	Hue
1	0	0%	0%
2	0	0%	0%
3	0	0%	0%
4	0	0%	0%
5	0	0%	0%
6	0	0%	0%
7	0	0%	0%
8	0	0%	0%
9	0	0%	0%
10	0	0%	0%
11	0	0%	0%
12	0	0%	0%
13	0	0%	0%
14	0	0%	0%
15	0	0%	0%
16	0	0%	0%

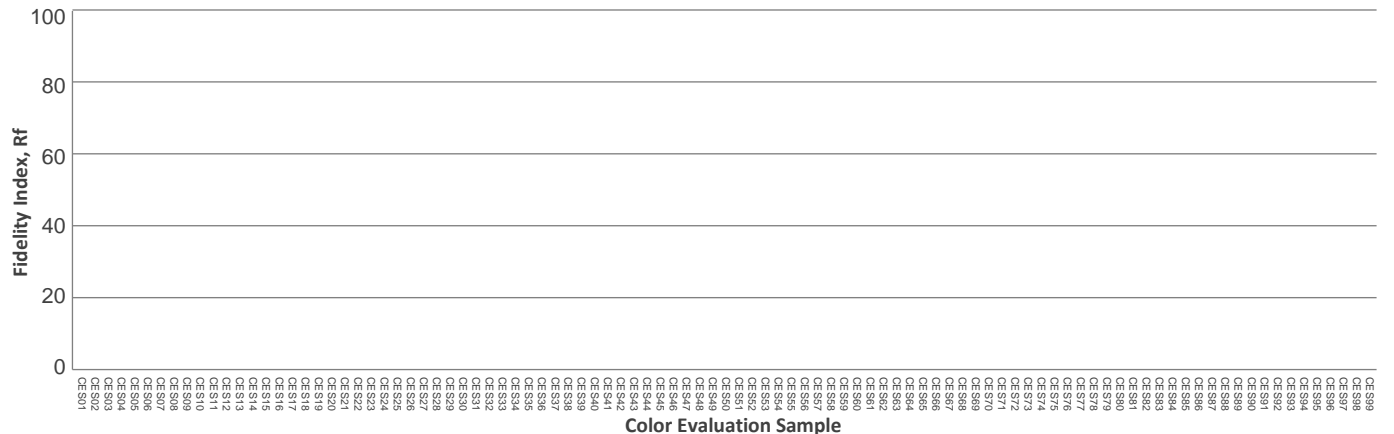
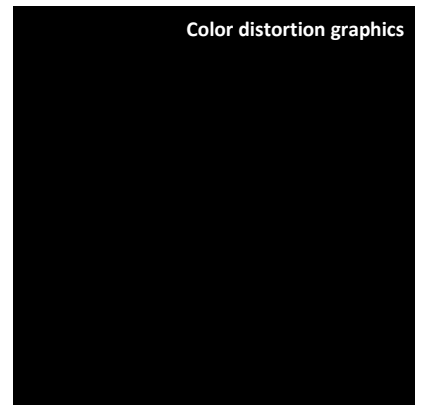
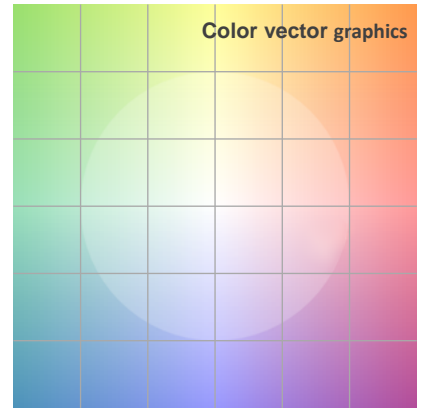
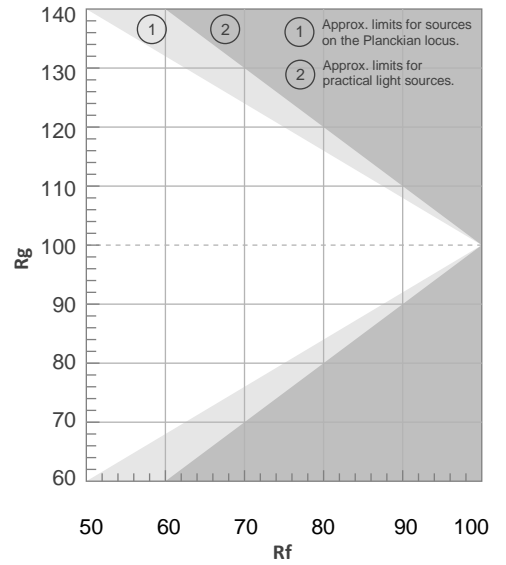



### ISO Diagrams

ISO Candela Diagram

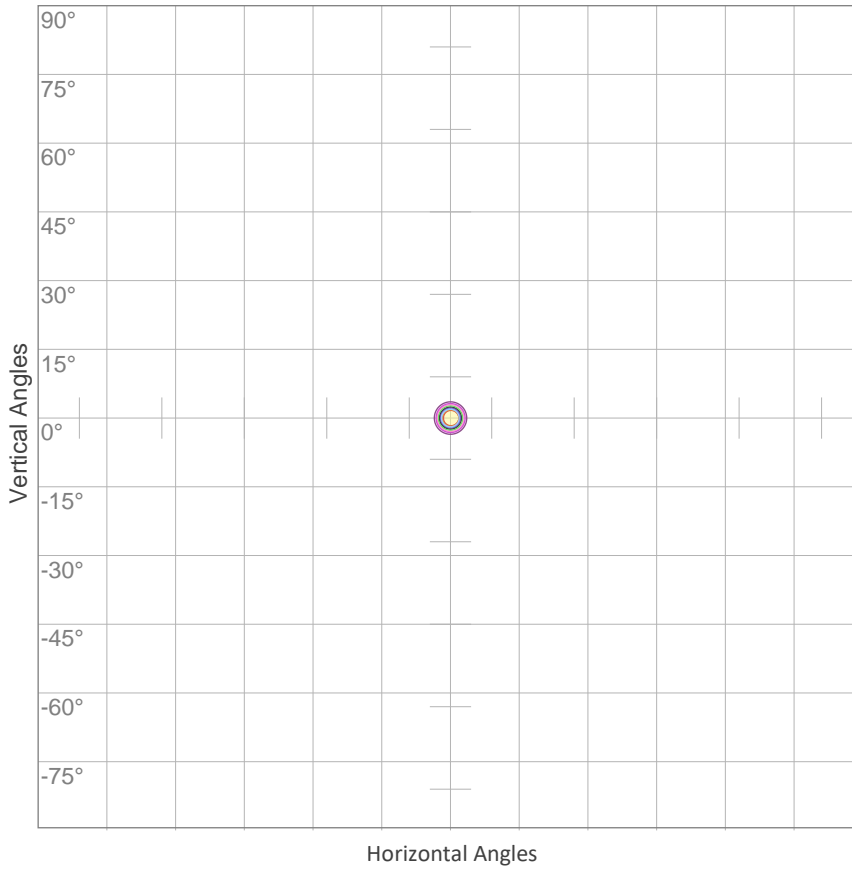

10%	40161 cd
20%	80322 cd
30%	120483 cd
40%	160643 cd
50%	200804 cd
60%	240965 cd
70%	281126 cd
80%	321287 cd
90%	361448 cd

Conditions:  
 Number of c-planes: 2  
 Candela at center: 401608 cd

ISO Lux Diagram

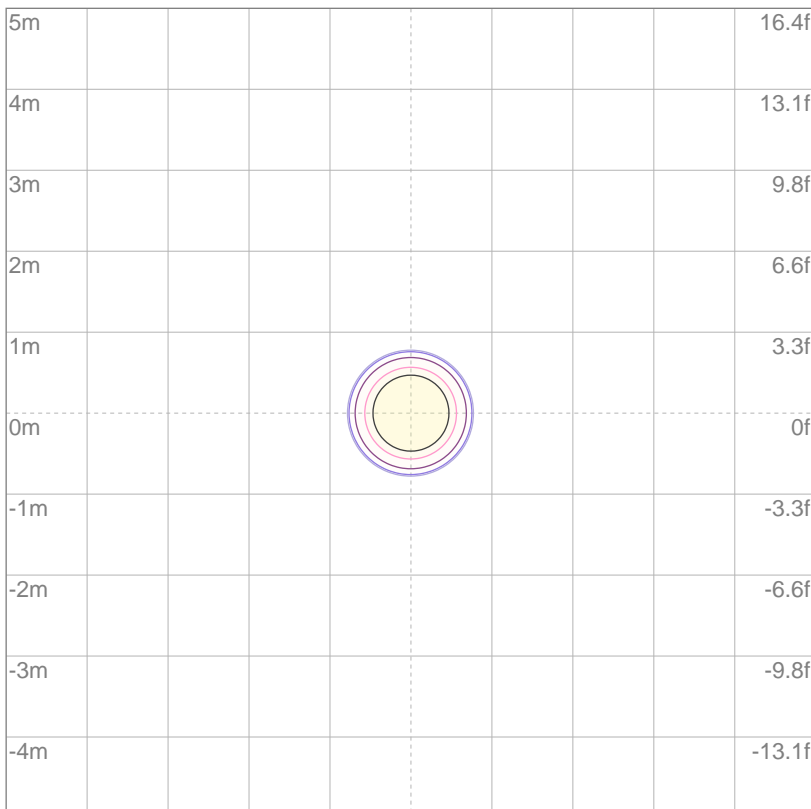

3%	120 lx
5%	201 lx
10%	402 lx
30%	1205 lx
50%	2008 lx

Conditions:  
 Number of c-planes: 2  
 Lux at center: 4016 lx

*Lux distribution on a surface when lamp is mounted at 10 meters from the surface.*

Mounting Height: 10 meters (33 feet)

# Photometric Report

## Total Lumen Output\*

Integrating Sphere      7282 lm

VISO Lab Spion          5646 lm

Beam Angle 50%	Field Angle 10%	Cutoff Angle 2.5%
29.6°	34.8°	37.1°

Color Temperature: 0 K

CRI: 0.0

TLCI: n/a

TM30: 0.0

CQS: 0.0

Voltage: 116 V, Current: 6.67 A

Power: 774 W

Efficacy: 7 Lumen/Watt

Measurement Date: 8/2/2019

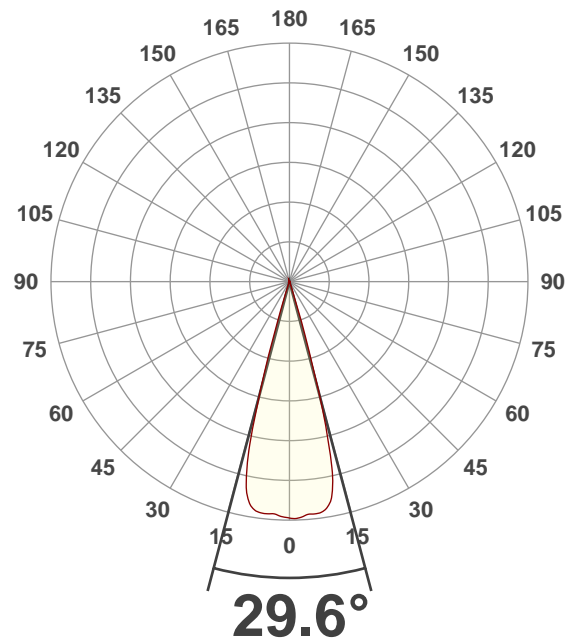

## Spectral Distribution

Dominant Wavelength 457 nm

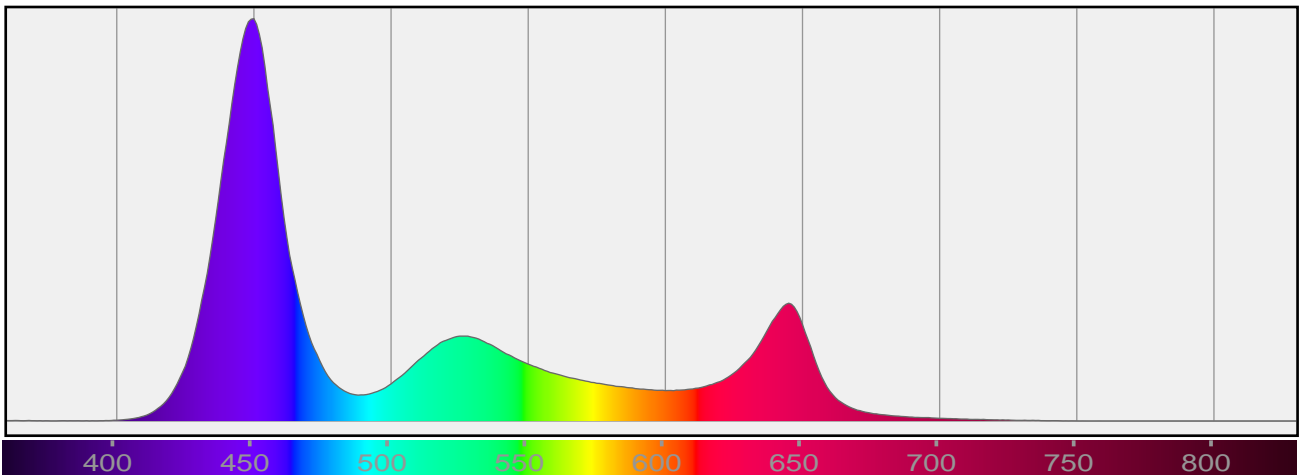

\*Total Lumen measurements by calibrated Everfine 2π Integrating Sphere and Viso Systems Lab Spion

### Beam Details

<b>Beam Angle 50%</b>	<b>Field Angle 10%</b>	<b>Cutoff Angle 2,5%</b>
<b>29.6°</b>	<b>34.8°</b>	<b>37.1°</b>

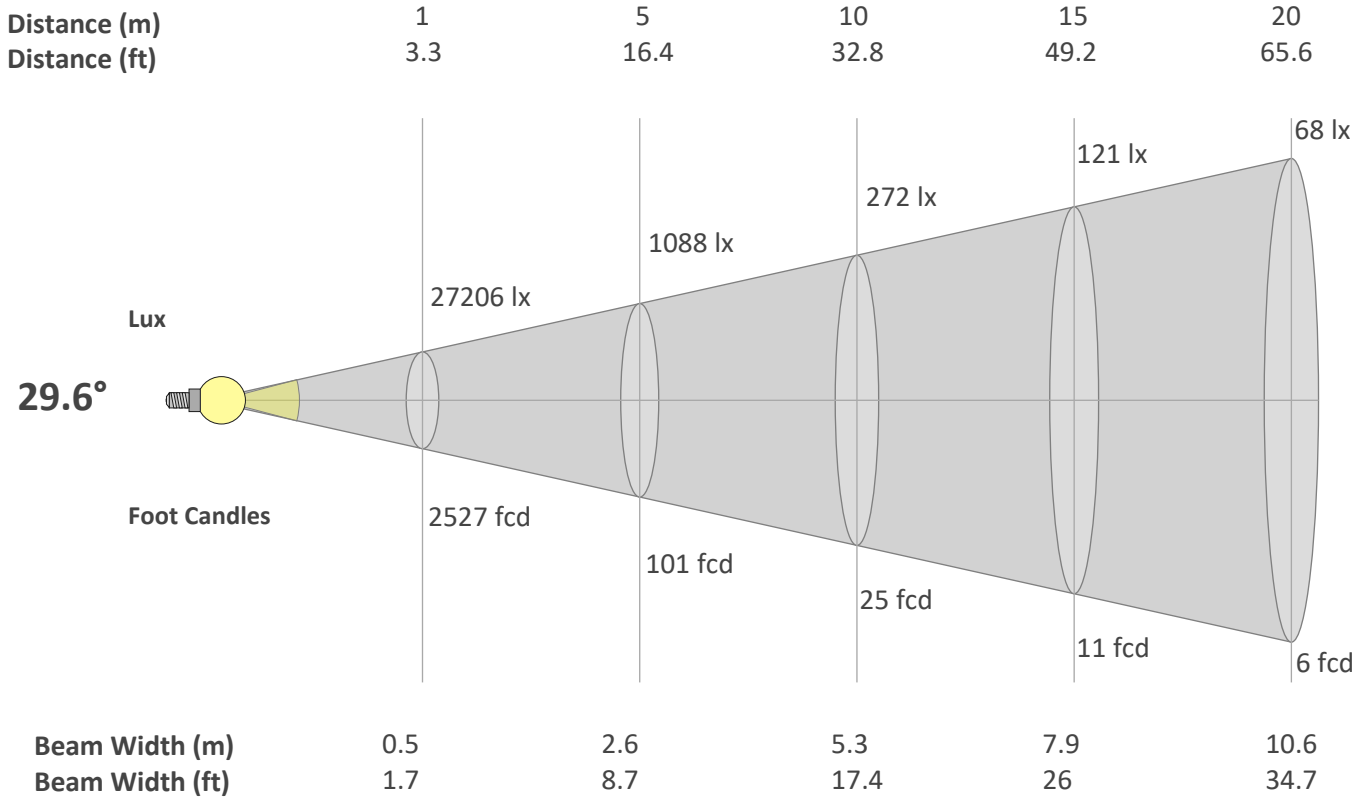

**Beam Intensities from 1-20m**

M	1	2	3	4	5	6	7	8	9	10	11	12	13	14	15	16	17	18	19	20
FT	3.3	6.6	9.8	13.1	16.4	19.7	23	26.2	29.5	32.8	36.1	39.4	42.7	45.9	49.2	52.5	55.8	59.1	62.3	65.6
LX	27206	6801	3023	1700	1088	756	555	425	336	272	225	189	161	139	121	106	94	84	75	68
FC	2527.5	631.9	280.8	158	101.1	70.2	51.6	39.5	31.2	25.3	20.9	17.6	15	12.9	11.2	9.9	8.7	7.8	7	6.3

**Linear Distribution**

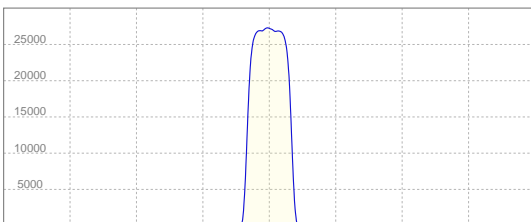

**Peak Candela**  
**27293 cd**

**Calculate Center Beam Intensities**  
**lux = 27293 / distance(m)<sup>2</sup>**  
**fc = 27293 / distance(ft)<sup>2</sup>**

### Color Details

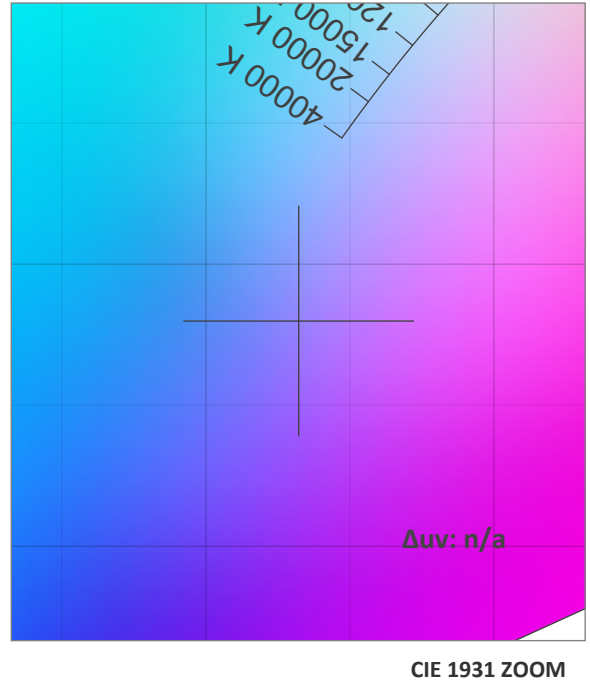
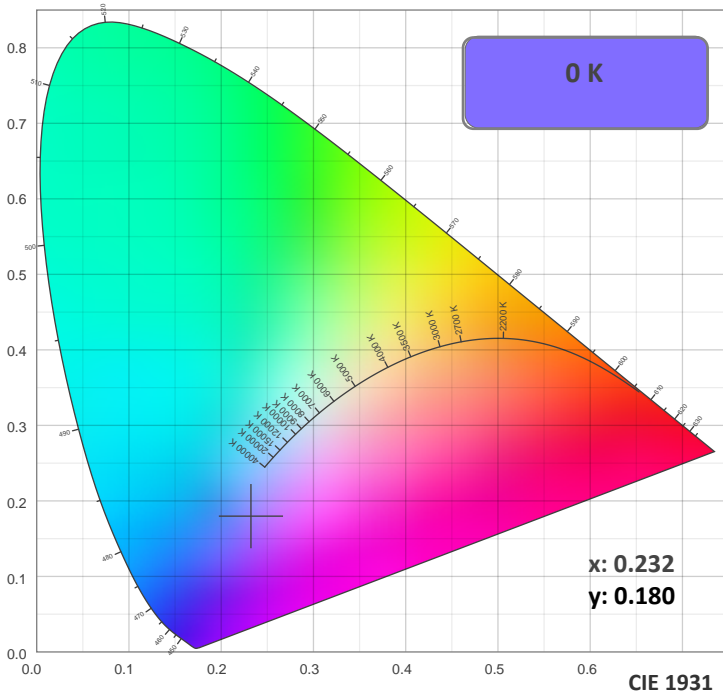

TM30: 0.0

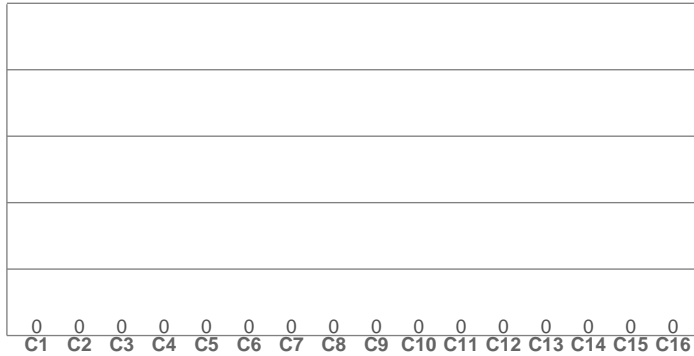

CRI R values, only R1-R8 are used to calculate final CRI value

R1	R2	R3	R4	R5	R6	R7	R8	R9	R10	R11	R12	R13	R14	R15
0.0	0.0	0.0	0.0	0.0	0.0	0.0	0.0	0.0	0.0	0.0	0.0	0.0	0.0	0.0

TM30 C Values, 16 binned values out of total of 99 C values

C1	C2	C3	C4	C5	C6	C7	C8	C9	C10	C11	C12	C13	C14	C15	C16
0.0	0.0	0.0	0.0	0.0	0.0	0.0	0.0	0.0	0.0	0.0	0.0	0.0	0.0	0.0	0.0

CQS Q Values

Q1	Q2	Q3	Q4	Q5	Q6	Q7	Q8	Q9	Q10	Q11	Q12	Q13	Q14	Q15
0.0	0.0	0.0	0.0	0.0	0.0	0.0	0.0	0.0	0.0	0.0	0.0	0.0	0.0	0.0

CRI: 0.0 (R1-R8)

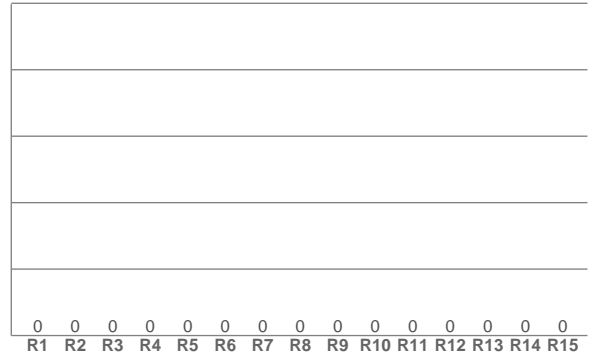

CQS: 0.0

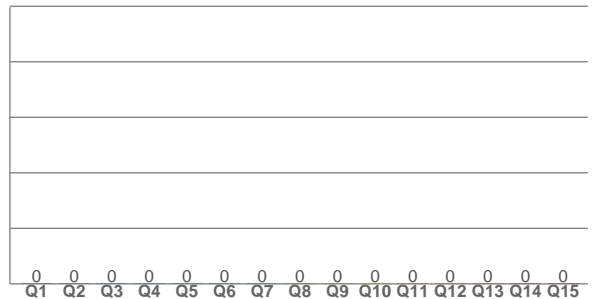

### Color Parameters

Color Temperature	Color Rendering Index	Red Component	Color Fidelity	Color Gamut	Color Quality Scale	Color Coordinate CIE 1931	Color Coordinate CIE 1931	Color Coordinate	Color Coordinate	Color Deviation from Black
CCT	CRI	CRI R9	TM30 Rf	TM30 Rg	CQS	x	y	u	v	Δuv
0 K	0.0	0.0	0.0	0.0	0.0	0.232	0.180	0.198	0.230	n/a

### TM30 Details

**Rf 0.0**  
Fidelity Index Rf

**Rg 0.0**  
Gamut Index Rg

Hue Bin	R <sub>f</sub>	Graphic shifts (%)	
		Chroma	Hue
1	0	0%	0%
2	0	0%	0%
3	0	0%	0%
4	0	0%	0%
5	0	0%	0%
6	0	0%	0%
7	0	0%	0%
8	0	0%	0%
9	0	0%	0%
10	0	0%	0%
11	0	0%	0%
12	0	0%	0%
13	0	0%	0%
14	0	0%	0%
15	0	0%	0%
16	0	0%	0%

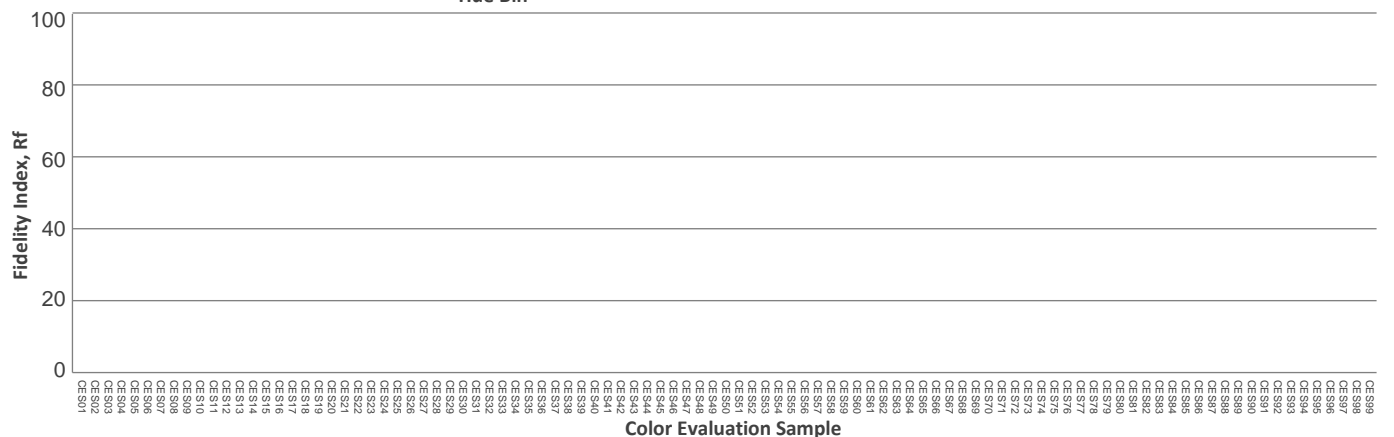
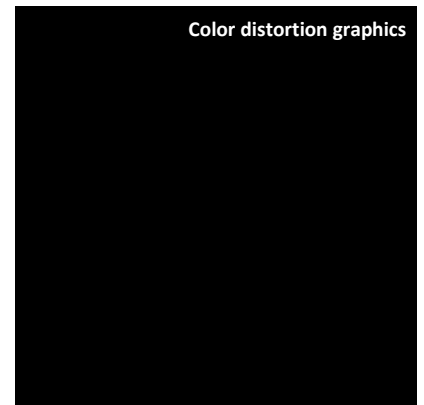
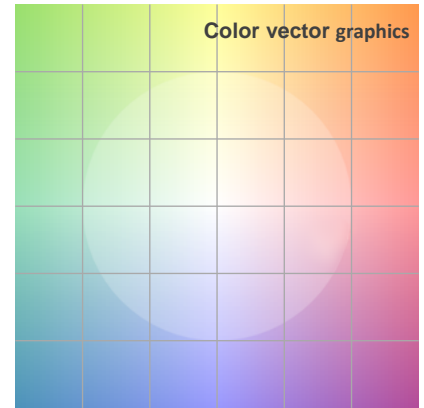
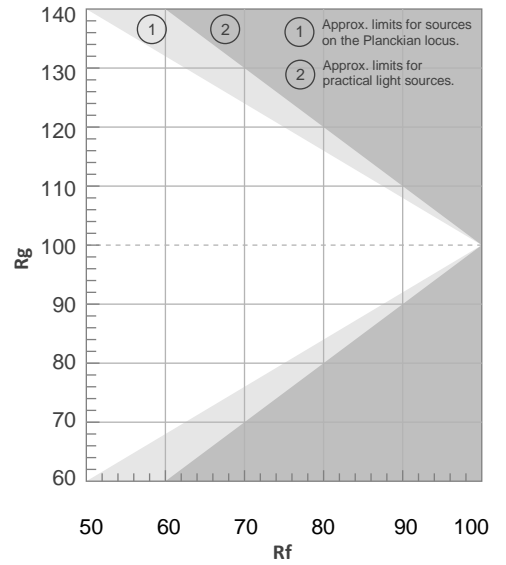

### ISO Diagrams

ISO Candela Diagram

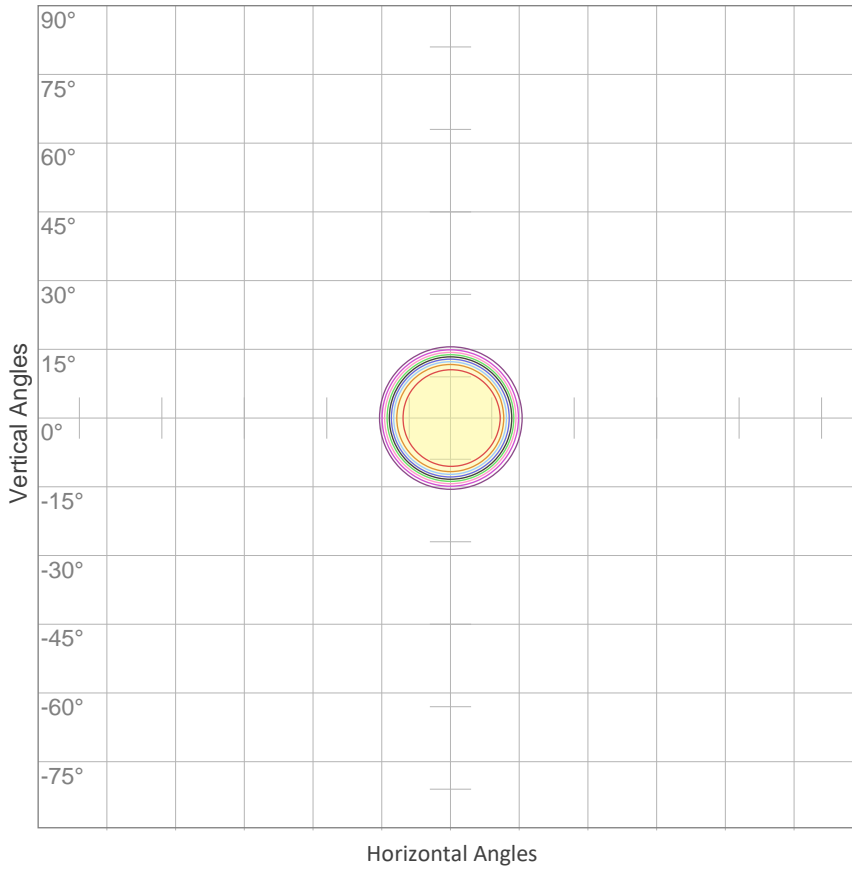

10%	2721 cd
20%	5441 cd
30%	8162 cd
40%	10882 cd
50%	13603 cd
60%	16323 cd
70%	19044 cd
80%	21765 cd
90%	24485 cd

Conditions:  
 Number of c-planes: 2  
 Candela at center: 27206 cd

ISO Lux Diagram

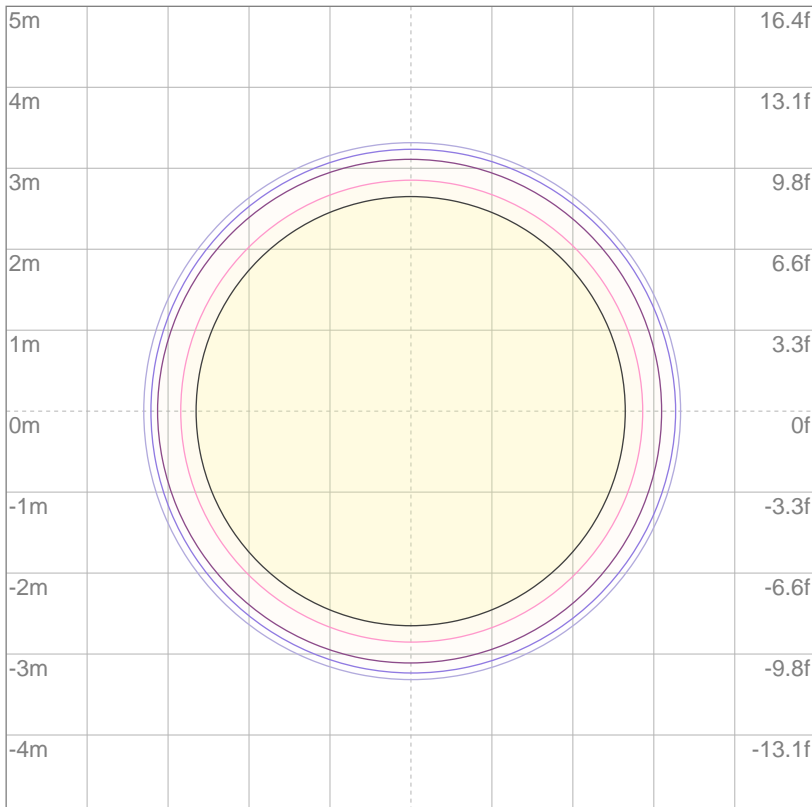

3%	8.16 lx
5%	13.6 lx
10%	27.2 lx
30%	81.6 lx
50%	136 lx

Conditions:  
 Number of c-planes: 2  
 Lux at center: 272 lx

*Lux distribution on a surface when lamp is mounted at 10 meters from the surface.*

Mounting Height: 10 meters (33 feet)

# Photometric Report

## Total Lumen Output\*

Integrating Sphere      7181 lm

VISO Lab Spion          6558 lm

Beam Angle 50%	Field Angle 10%	Cutoff Angle 2.5%
56.4°	74°	80.1°

Color Temperature: 0 K

CRI: 0.0

TLCI: n/a

TM30: 0.0

CQS: 0.0

Voltage: 116 V, Current: 5.80 A

Power: 674.9 W

Efficacy: 10 Lumen/Watt

Measurement Date: 8/2/2019

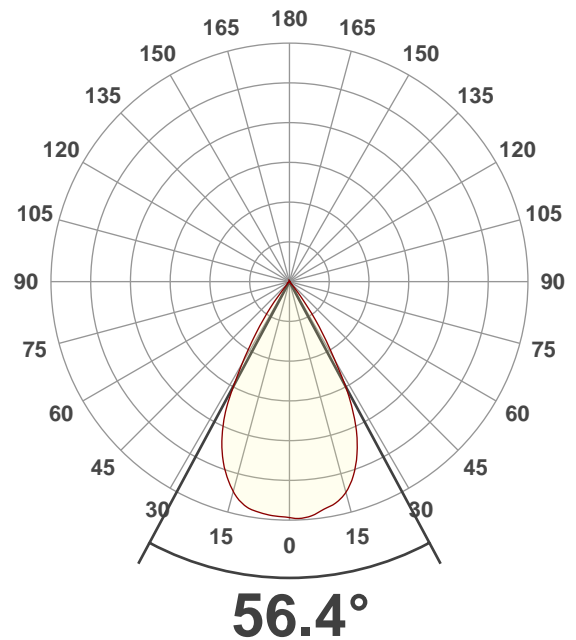

## Spectral Distribution

Dominant Wavelength 457 nm

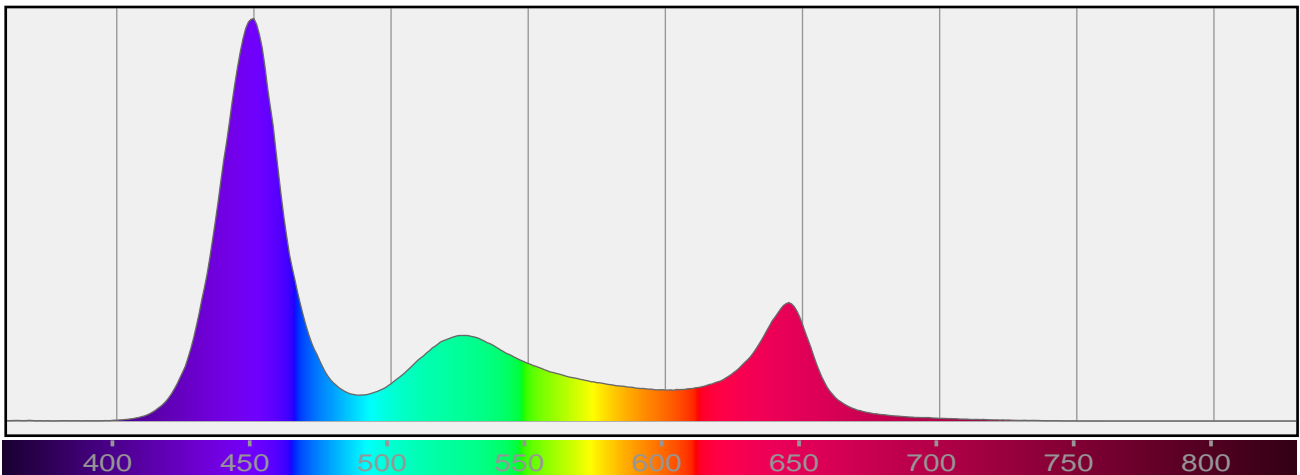

\*Total Lumen measurements by calibrated Everfine 2π Integrating Sphere and Viso Systems Lab Spion

### Beam Details

<b>Beam Angle 50%</b>	<b>Field Angle 10%</b>	<b>Cutoff Angle 2,5%</b>
<b>56.4°</b>	<b>74°</b>	<b>80.1°</b>

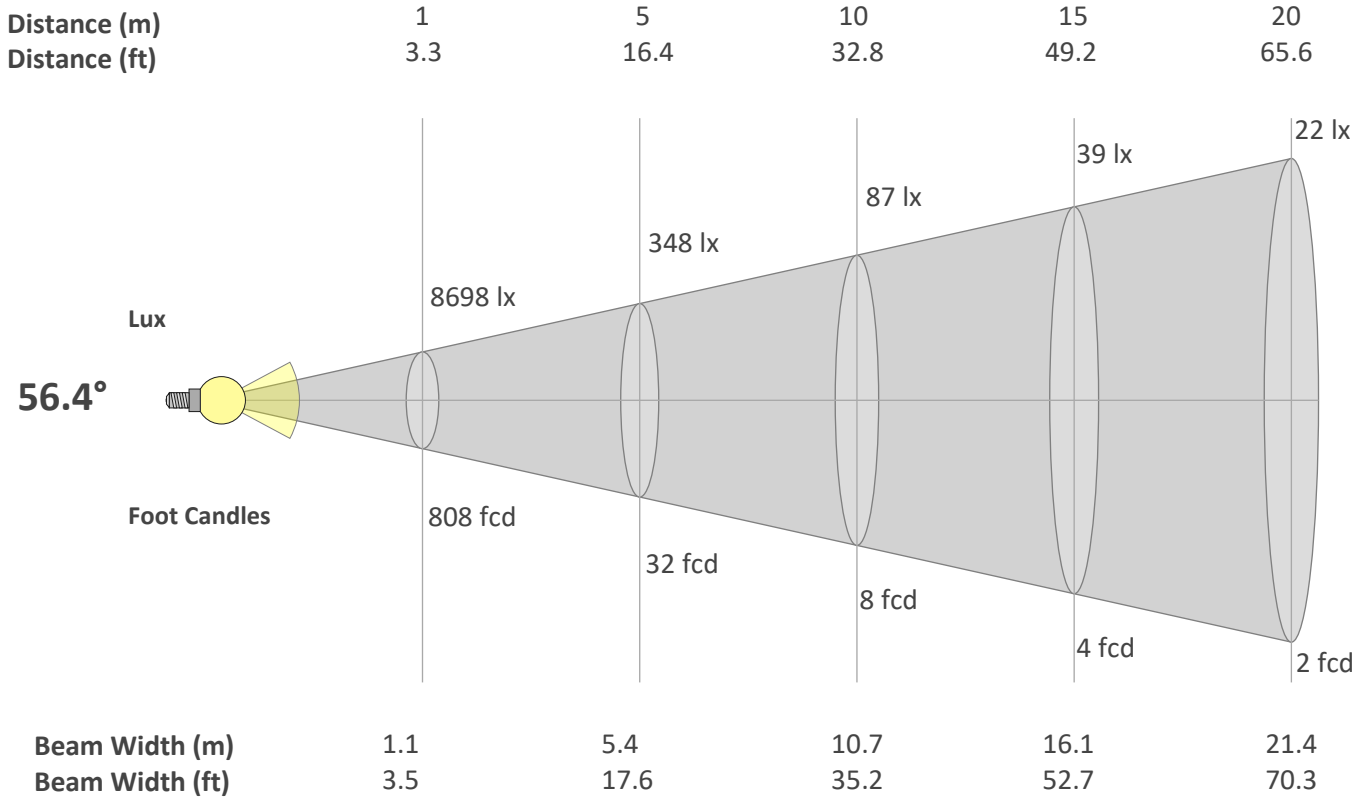

#### Beam Intensities from 1-20m

M	1	2	3	4	5	6	7	8	9	10	11	12	13	14	15	16	17	18	19	20
FT	3.3	6.6	9.8	13.1	16.4	19.7	23	26.2	29.5	32.8	36.1	39.4	42.7	45.9	49.2	52.5	55.8	59.1	62.3	65.6
LX	8698	2175	966	544	348	242	178	136	107	87	72	60	51	44	39	34	30	27	24	22
FC	808.1	202	89.8	50.5	32.3	22.4	16.5	12.6	10	8.1	6.7	5.6	4.8	4.1	3.6	3.2	2.8	2.5	2.2	2

#### Linear Distribution

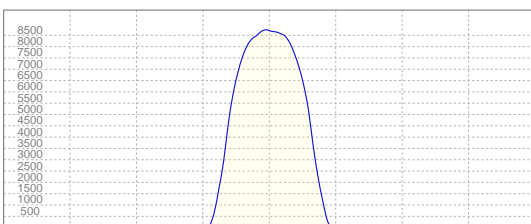

**Peak Candela**  
**8740 cd**

**Calculate Center Beam Intensities**

$lux = 8740 / distance(m)^2$   
 $fc = 8740 / distance(ft)^2$



**Color Details**

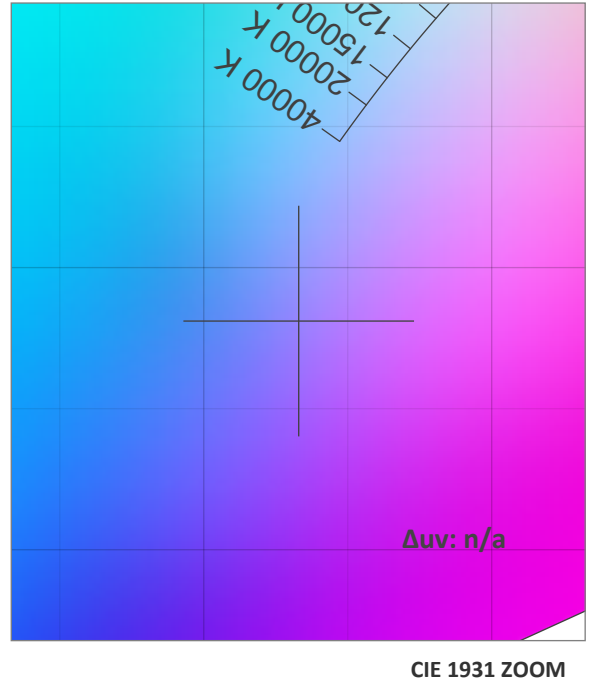
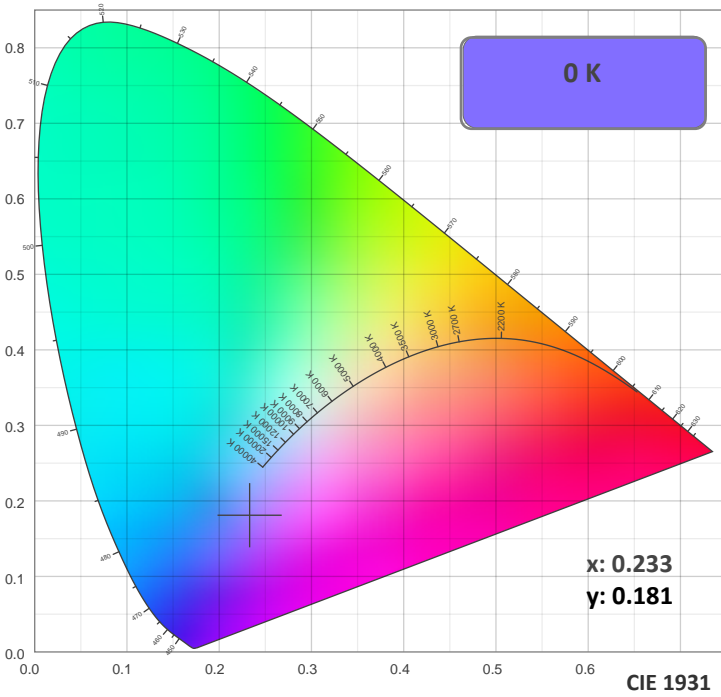

**TM30: 0.0**

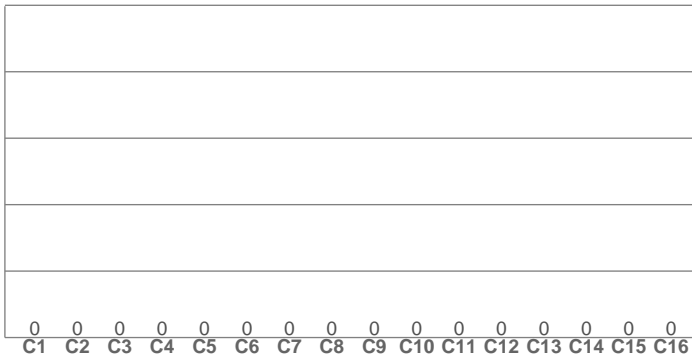

**CRI: 0.0 (R1-R8)**

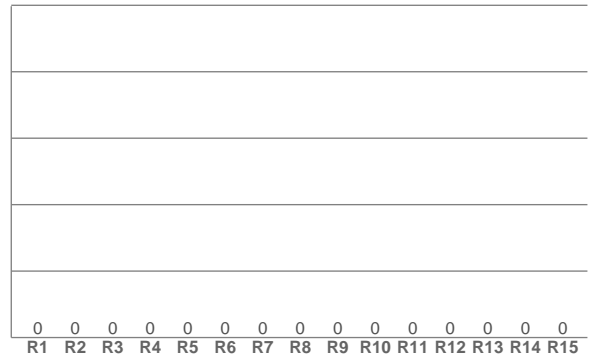

CRI R values, only R1-R8 are used to calculate final CRI value

R1	R2	R3	R4	R5	R6	R7	R8	R9	R10	R11	R12	R13	R14	R15
0.0	0.0	0.0	0.0	0.0	0.0	0.0	0.0	0.0	0.0	0.0	0.0	0.0	0.0	0.0

TM30 C Values, 16 binned values out of total of 99 C values

C1	C2	C3	C4	C5	C6	C7	C8	C9	C10	C11	C12	C13	C14	C15	C16
0.0	0.0	0.0	0.0	0.0	0.0	0.0	0.0	0.0	0.0	0.0	0.0	0.0	0.0	0.0	0.0

CQS Q Values

Q1	Q2	Q3	Q4	Q5	Q6	Q7	Q8	Q9	Q10	Q11	Q12	Q13	Q14	Q15
0.0	0.0	0.0	0.0	0.0	0.0	0.0	0.0	0.0	0.0	0.0	0.0	0.0	0.0	0.0

**CQS: 0.0**

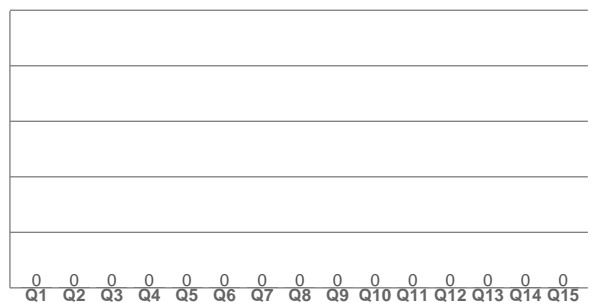

**Color Parameters**

Color Temperature	Color Rendering Index	Red Component	Color Fidelity	Color Gamut	Color Quality Scale	Color Coordinate CIE 1931	Color Coordinate CIE 1931	Color Coordinate	Color Coordinate	Color Deviation from Black
CCT	CRI	CRI R9	TM30 Rf	TM30 Rg	CQS	x	y	u	v	Δuv
0 K	0.0	0.0	0.0	0.0	0.0	0.233	0.181	0.198	0.231	n/a

TM30 Details

**Rf 0.0**  
Fidelity Index Rf

**Rg 0.0**  
Gamut Index Rg

Hue Bin	Rr	Graphic shifts (%)	
		Chroma	Hue
1	0	0%	0%
2	0	0%	0%
3	0	0%	0%
4	0	0%	0%
5	0	0%	0%
6	0	0%	0%
7	0	0%	0%
8	0	0%	0%
9	0	0%	0%
10	0	0%	0%
11	0	0%	0%
12	0	0%	0%
13	0	0%	0%
14	0	0%	0%
15	0	0%	0%
16	0	0%	0%

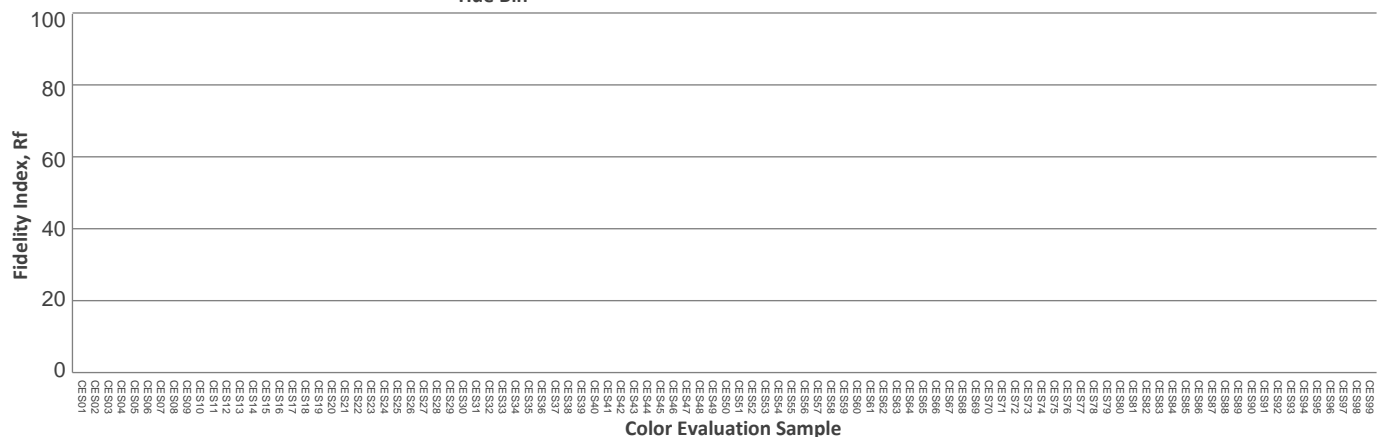
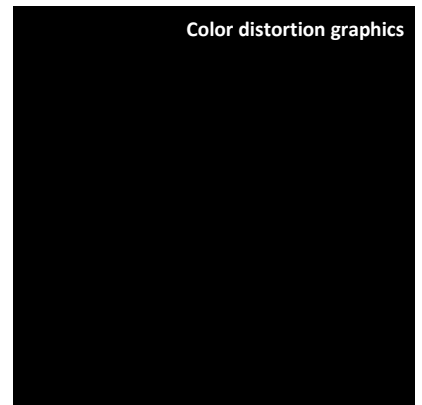
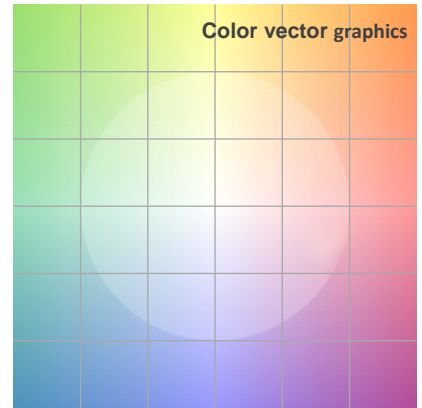
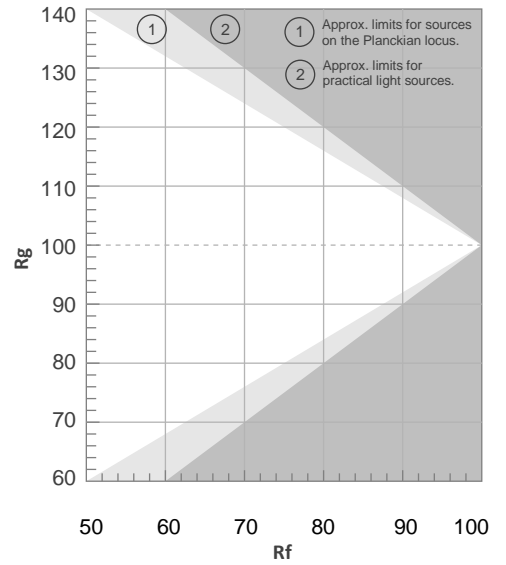

### ISO Diagrams

ISO Candela Diagram

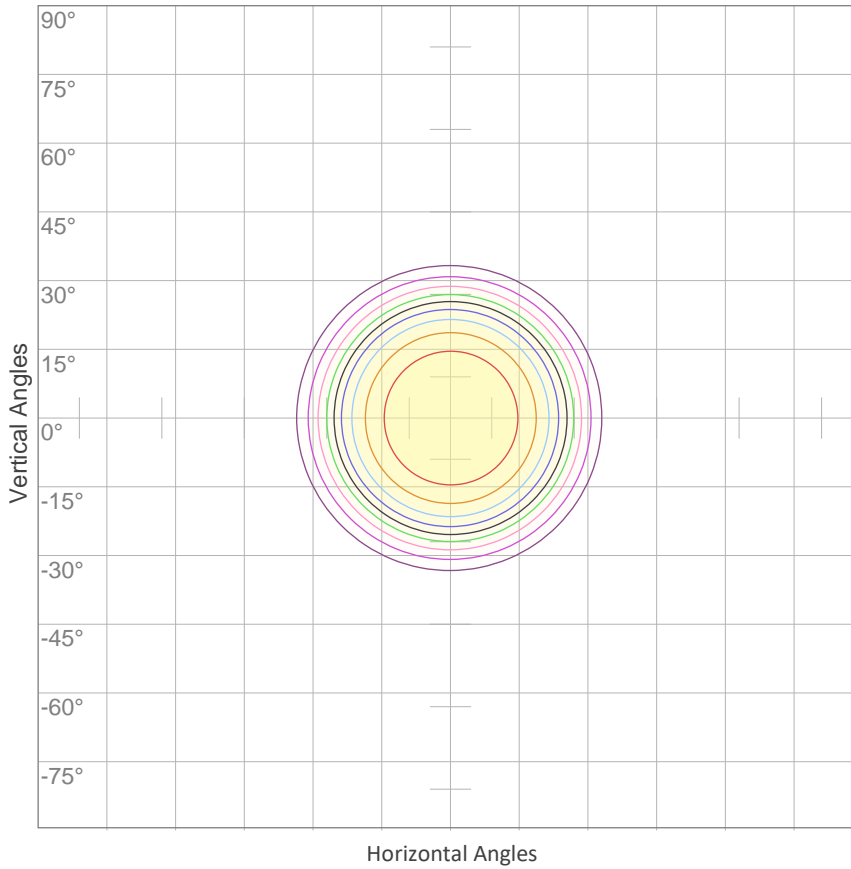

10%	870 cd
20%	1740 cd
30%	2610 cd
40%	3479 cd
50%	4349 cd
60%	5219 cd
70%	6089 cd
80%	6959 cd
90%	7829 cd

Conditions:

Number of c-planes: 2

Candela at center: 8698 cd

ISO Lux Diagram

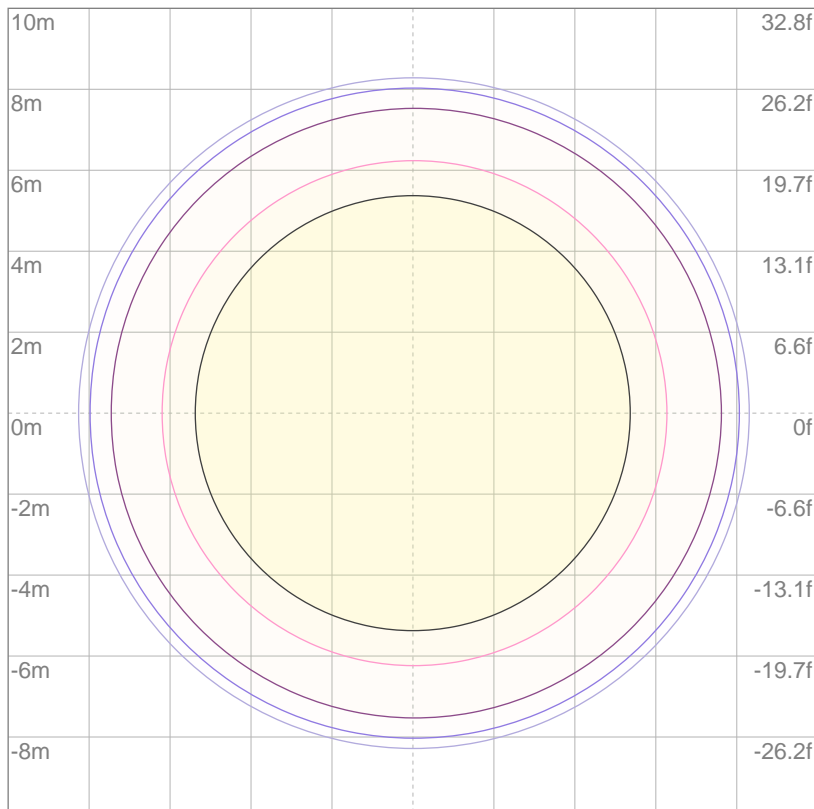

3%	2.61 lx
5%	4.35 lx
10%	8.70 lx
30%	26.1 lx
50%	43.5 lx

Conditions:

Number of c-planes: 2

Lux at center: 87.0 lx

*Lux distribution on a surface when lamp is mounted at 10 meters from the surface.*

Mounting Height: 10 meters (33 feet)

# Photometric Report

## Total Lumen Output\*

Integrating Sphere      N/A  
 VISO Lab Spion          3778 lm

Beam Angle 50%	Field Angle 10%	Cutoff Angle 2.5%
30°	35.4°	37.4°

Color Temperature: 3281 K

CRI: 74.7

TLCI: 52

TM30: 64.0

CQS: 77.0

Voltage: 116 V, Current: 2.69 A

Power: 312 W

Efficacy: 12 Lumen/Watt

Measurement Date: 8/2/2019

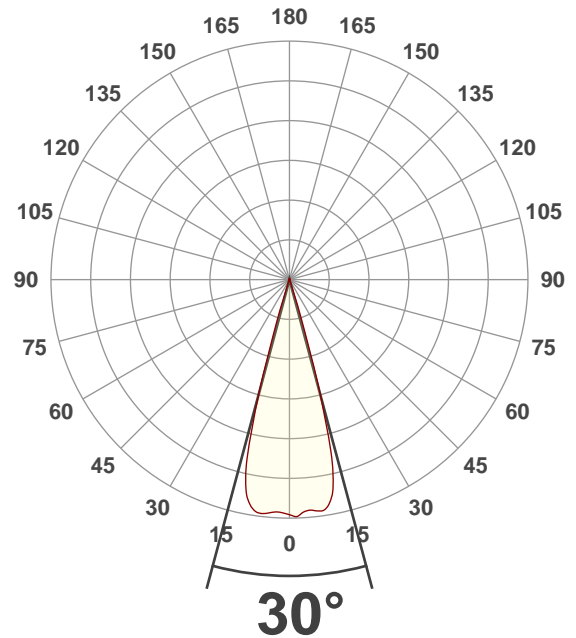

## Spectral Distribution

Dominant Wavelength 829 nm

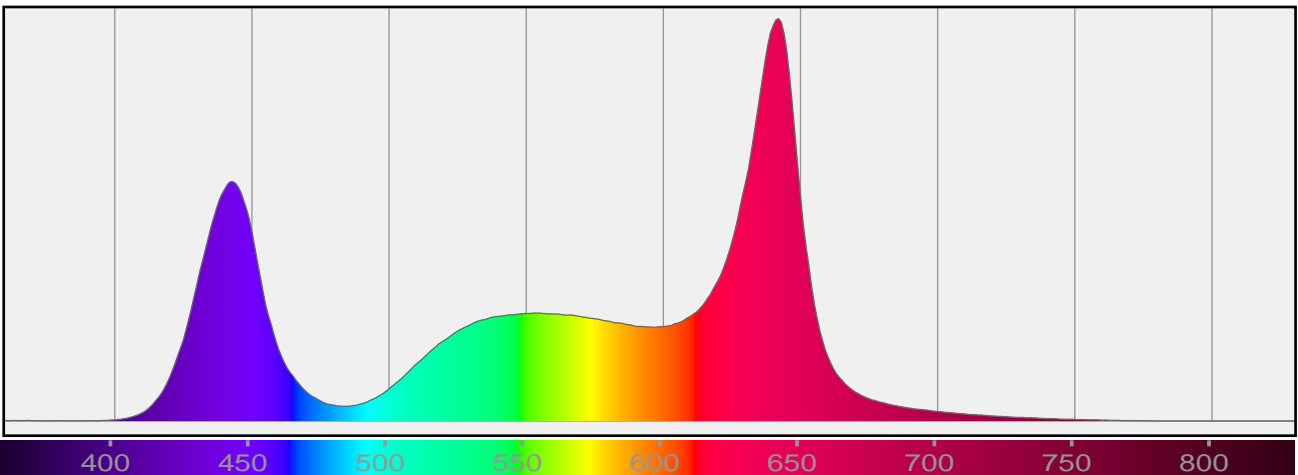

\*Total Lumen measurements by calibrated Everfine 2π Integrating Sphere and Viso Systems Lab Spion

### Beam Details

<b>Beam Angle 50%</b>	<b>Field Angle 10%</b>	<b>Cutoff Angle 2,5%</b>
<b>30°</b>	<b>35.4°</b>	<b>37.4°</b>

Distance (m)	1	5	10	15	20
Distance (ft)	3.3	16.4	32.8	49.2	65.6

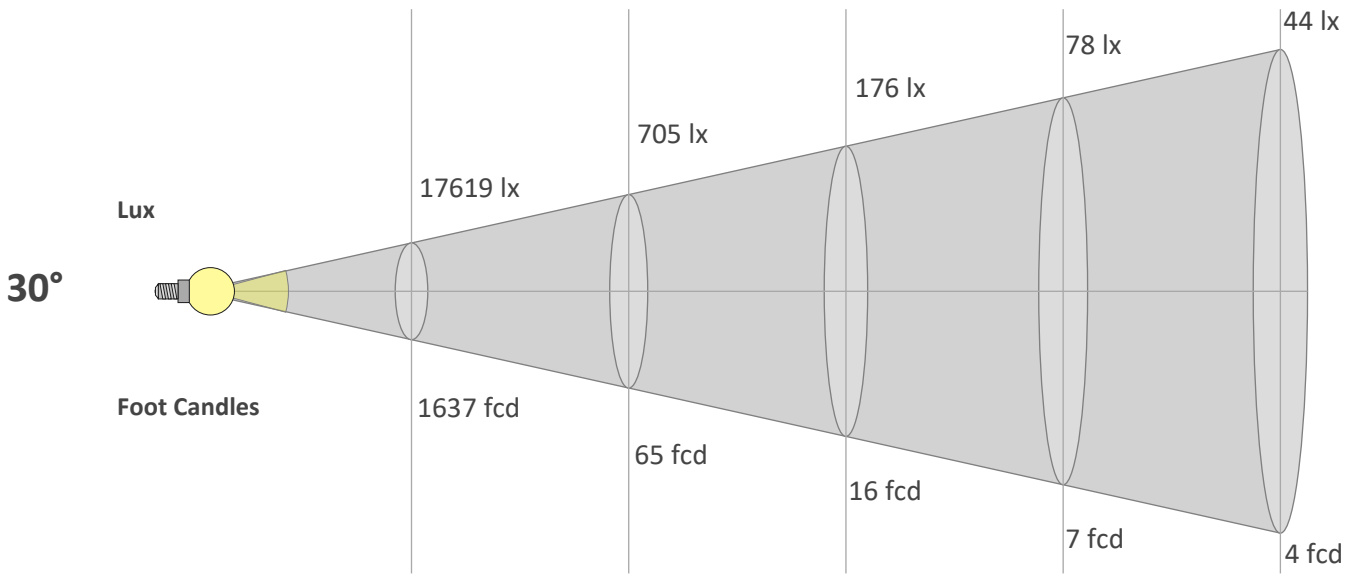

Beam Width (m)	0.5	2.7	5.4	8	10.7
Beam Width (ft)	1.8	8.8	17.6	26.4	35.2

Beam Intensities from 1-20m

M	1	2	3	4	5	6	7	8	9	10	11	12	13	14	15	16	17	18	19	20
FT	3.3	6.6	9.8	13.1	16.4	19.7	23	26.2	29.5	32.8	36.1	39.4	42.7	45.9	49.2	52.5	55.8	59.1	62.3	65.6
LX	17619	4405	1958	1101	705	489	360	275	218	176	146	122	104	90	78	69	61	54	49	44
FC	1636.8	409.2	181.9	102.3	65.5	45.5	33.4	25.6	20.2	16.4	13.5	11.4	9.7	8.4	7.3	6.4	5.7	5.1	4.5	4.1

Linear Distribution

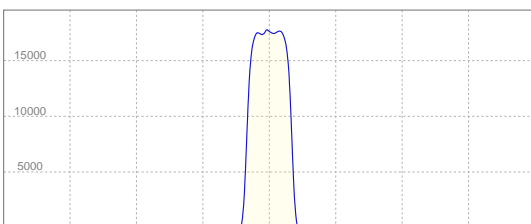

**Peak Candela**  
**17764 cd**

**Calculate Center Beam Intensities**  
 $lux = 17764 / distance(m)^2$   
 $fc = 17764 / distance(ft)^2$

### Color Details

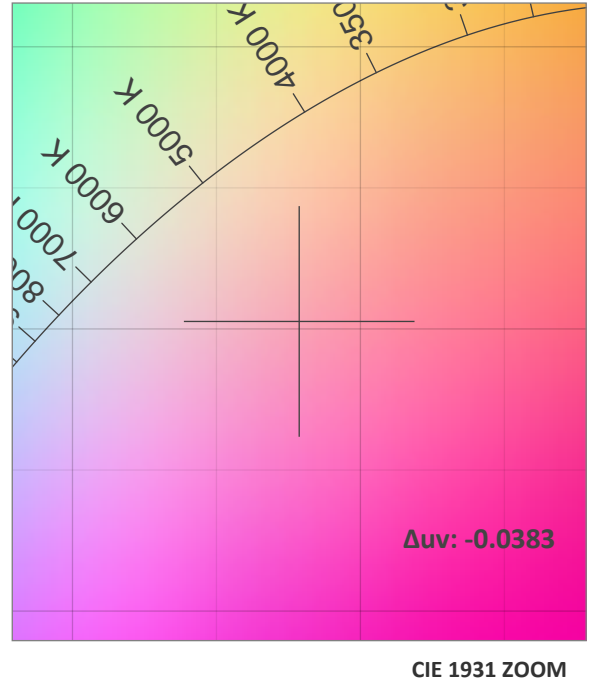
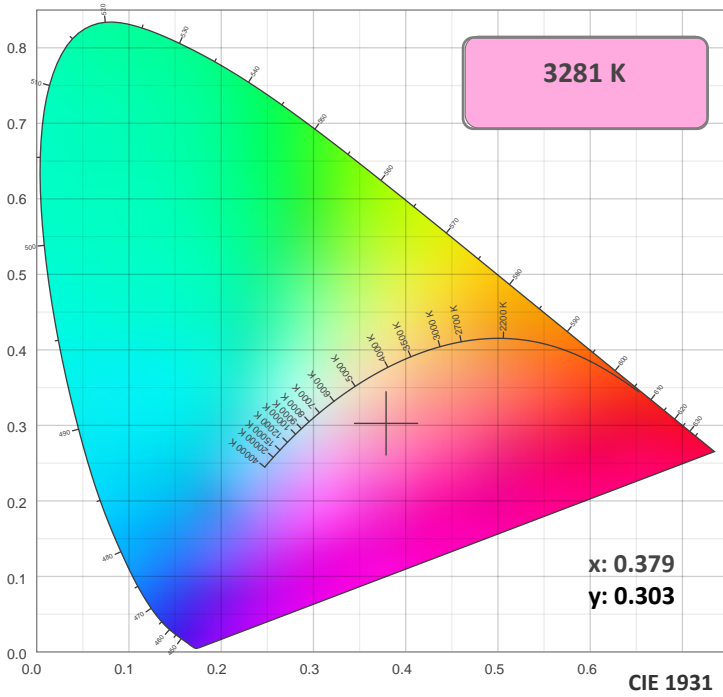

TM30: 64.0

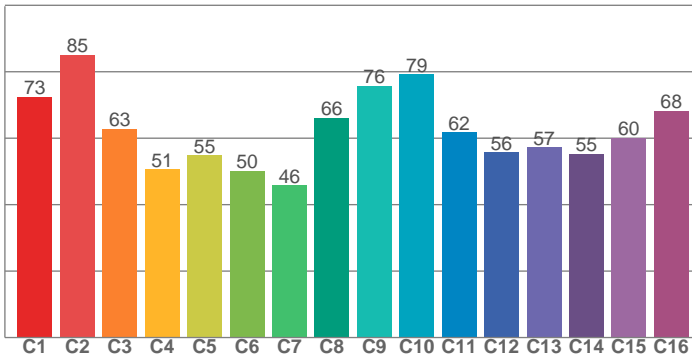

CRI: 74.7 (R1-R8)

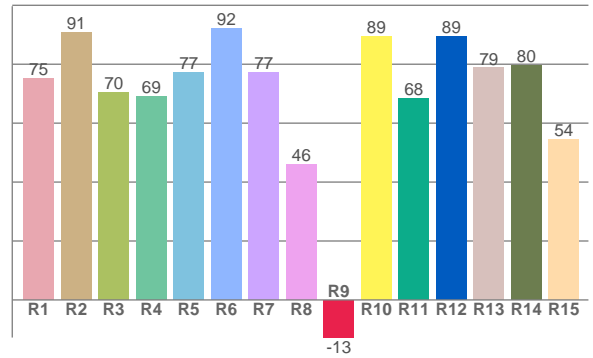

CRI R values, only R1-R8 are used to calculate final CRI value

R1	R2	R3	R4	R5	R6	R7	R8	R9	R10	R11	R12	R13	R14	R15
75.2	90.7	70.3	68.9	77.2	92.2	77.4	46.0	-12.8	89.5	68.4	89.4	78.7	79.5	54.5

TM30 C Values, 16 binned values out of total of 99 C values

C1	C2	C3	C4	C5	C6	C7	C8	C9	C10	C11	C12	C13	C14	C15	C16
72.5	85.0	62.9	50.6	54.9	50.2	45.8	66.2	75.7	79.2	61.7	55.7	57.2	55.2	60.2	68.2

CQS Q Values

Q1	Q2	Q3	Q4	Q5	Q6	Q7	Q8	Q9	Q10	Q11	Q12	Q13	Q14	Q15
95.3	79.8	56.5	73.3	83.2	66.4	75.2	97.2	74.0	70.2	74.2	82.8	93.3	89.2	91.4

CQS: 77.0

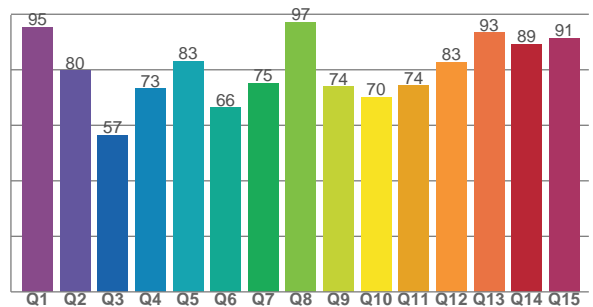

### Color Parameters

Color Temperature	Color Rendering Index	Red Component	Color Fidelity	Color Gamut	Color Quality Scale	Color Coordinate CIE 1931	Color Coordinate CIE 1931	Color Coordinate	Color Coordinate	Color Diviation from Black
CCT	CRI	CRI R9	TM30 Rf	TM30 Rg	CQS	x	y	u	v	Δuv
3281 K	74.7	-12.8	64.0	126.3	77.0	0.379	0.303	0.258	0.309	-0.0383

TM30 Details

**Rf 64.0**  
Fidelity Index Rf

**Rg 126.3**  
Gamut Index Rg

Hue Bin	R <sub>f</sub>	Graphic shifts (%)	
		Chroma	Hue
1	73	12%	-4%
2	85	4%	3%
3	63	5%	16%
4	51	14%	25%
5	55	27%	21%
6	50	29%	9%
7	46	30%	-7%
8	66	13%	-15%
9	76	5%	-14%
10	79	-7%	-5%
11	62	-6%	20%
12	56	2%	27%
13	57	13%	27%
14	55	20%	29%
15	60	23%	11%
16	68	20%	-2%

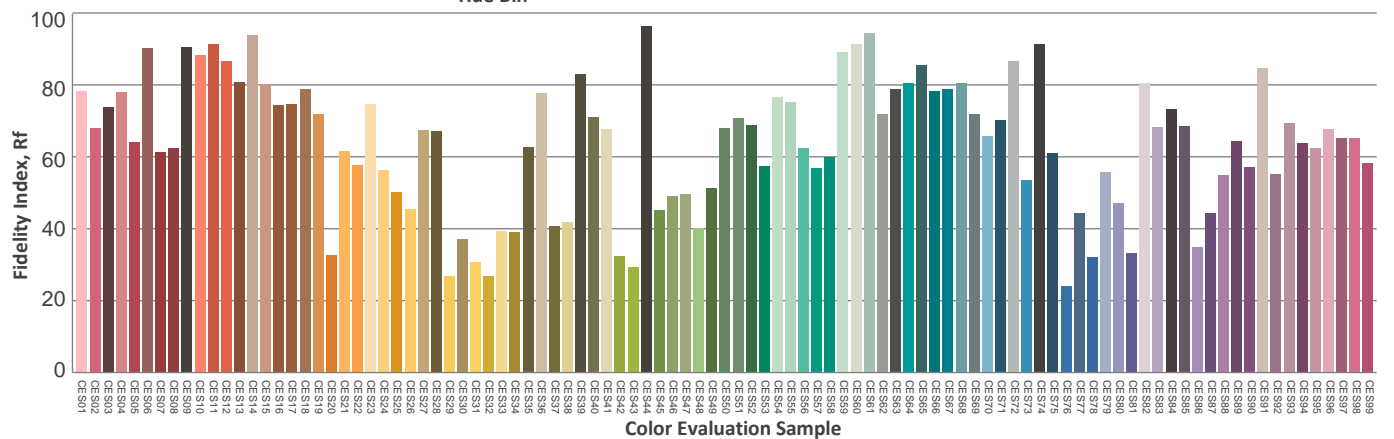
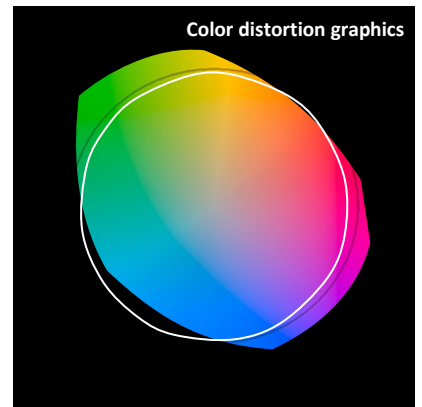
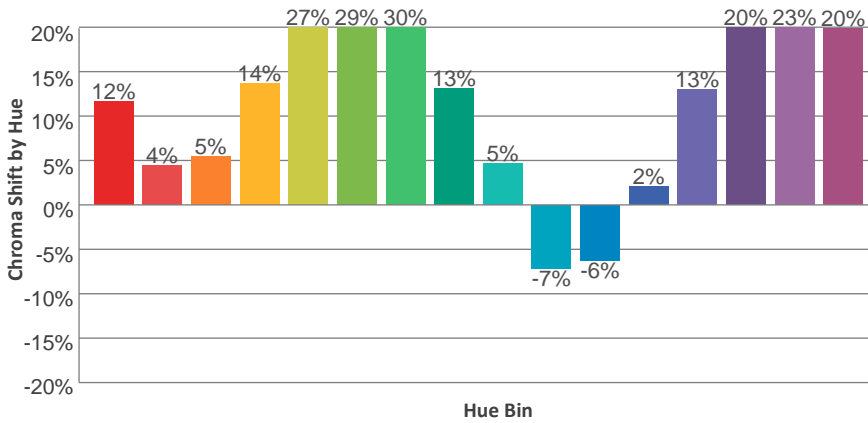
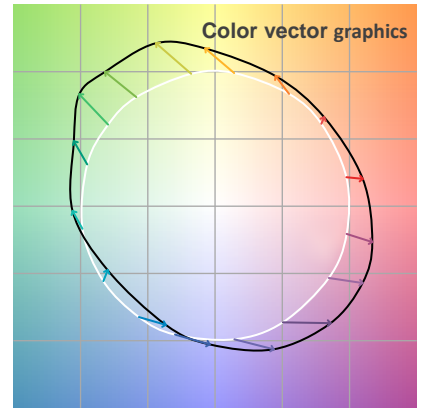
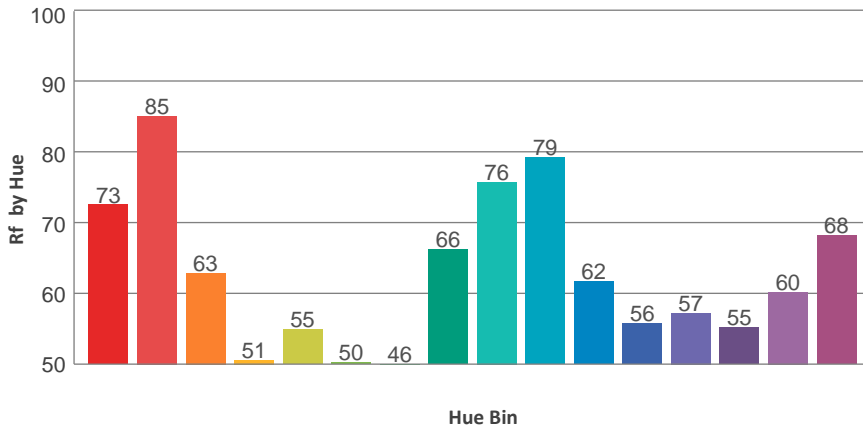
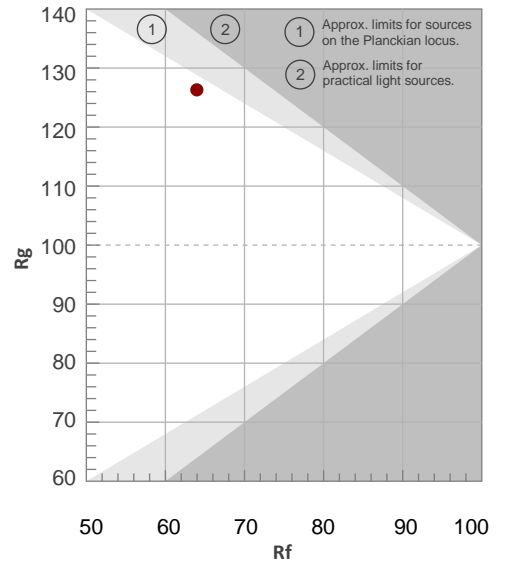

### ISO Diagrams

ISO Candela Diagram

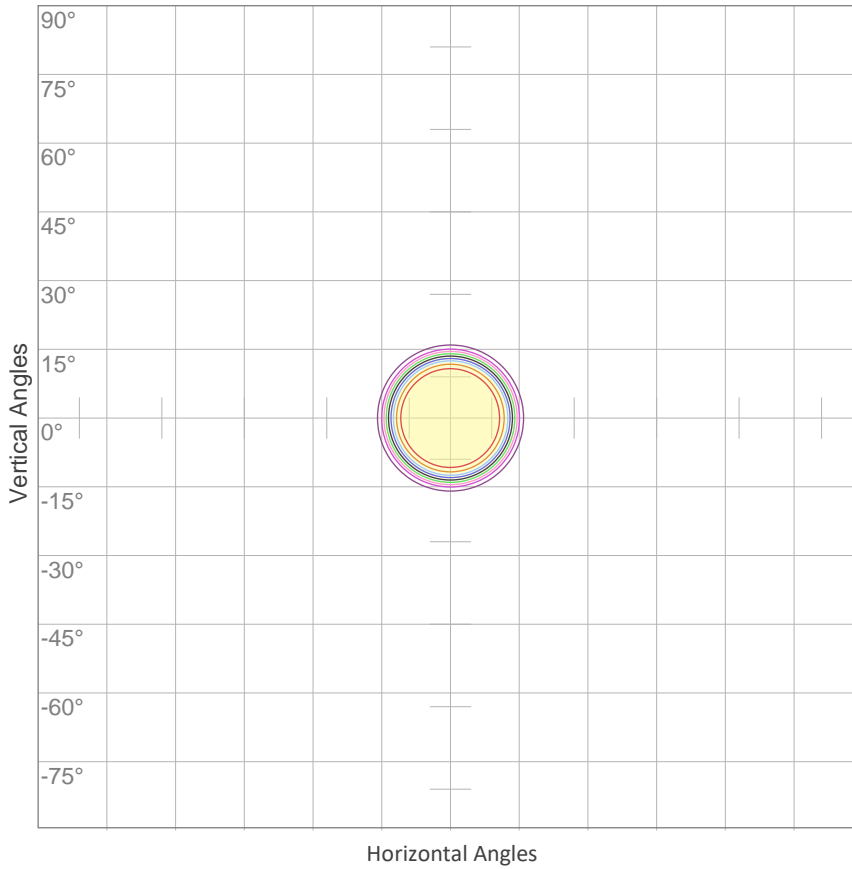

10%	1762 cd
20%	3524 cd
30%	5286 cd
40%	7048 cd
50%	8809 cd
60%	10571 cd
70%	12333 cd
80%	14095 cd
90%	15857 cd

Conditions:  
 Number of c-planes: 2  
 Candela at center: 17619 cd

ISO Lux Diagram

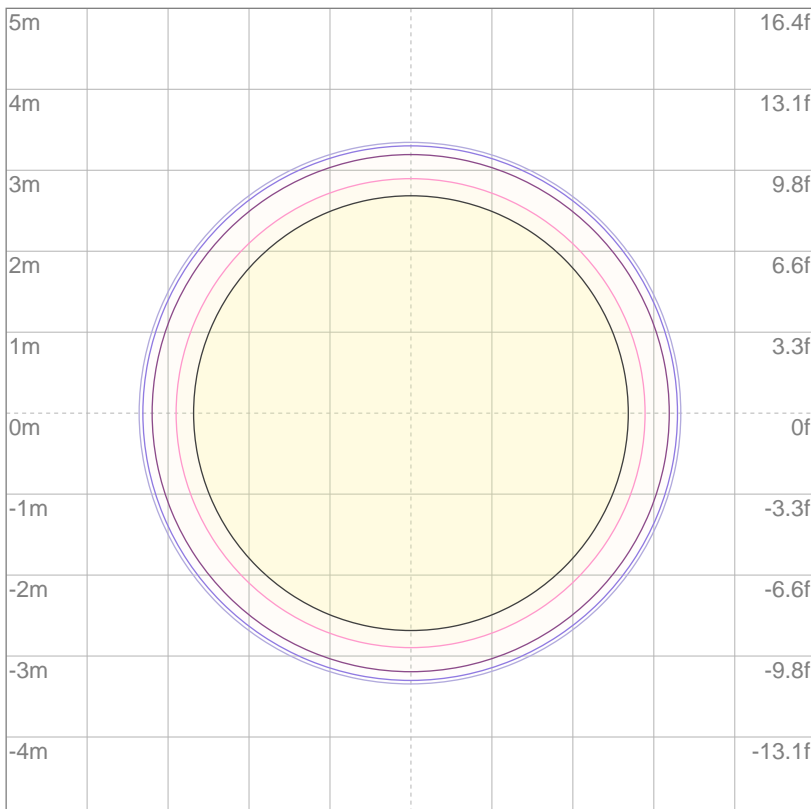

3%	5.29 lx
5%	8.81 lx
10%	17.6 lx
30%	52.9 lx
50%	88.1 lx

Conditions:  
 Number of c-planes: 2  
 Lux at center: 176 lx

*Lux distribution on a surface when lamp is mounted at 10 meters from the surface.*

Mounting Height: 10 meters (33 feet)