

LEVEL Q7™

user manual

©2014 ELATION PROFESSIONAL all rights reserved. Information, specifications, diagrams, images, and instructions herein are subject to change without notice. ELATION PROFESSIONAL logo and identifying product names and numbers herein are trademarks of ELATION PROFESSIONAL. Copyright protection claimed includes all forms and matters of copyrightable materials and information now allowed by statutory or judicial law or hereinafter granted. Product names used in this document may be trademarks or registered trademarks of their respective companies and are hereby acknowledged. All non-ELATION brands and product names are trademarks or registered trademarks of their respective companies.

ELATION PROFESSIONAL and all affiliated companies hereby disclaim any and all liabilities for property, equipment, building, and electrical damages, injuries to any persons, and direct or indirect economic loss associated with the use or reliance of any information contained within this document, and/or as a result of the improper, unsafe, insufficient and negligent assembly, installation, rigging, and operation of this product.

Elation Professional USA | 6122 S. Eastern Ave. | Los Angeles, CA. 90040

323-582-3322 | 323-832-9142 fax | www.elationlighting.com | info@elationlighting.com

Elation Professional B.V. | Junostraat 2 | 6468 EW Kerkrade, Netherlands

+31 45 546 85 66 | +31 45 546 85 96 fax | www.elationlighting.eu | info@elationlighting.eu

DOCUMENT VERSION



Please check www.elationlighting.com for the latest revision/update of this manual.

Date	Document Version	Software Version	DMX Channel Modes	Notes
7/2014	2	≥1.0.3	4/5/7/12/17	Added 16bit individual RGBW and ALL FINE dimming adjustment, dimming curve modes, internal program macro speed control, and color mode (white balance) setting.

CONTENTS

General Information	4
Warranty	6
Safety Instructions	7
General Guidelines	8
Fixture Overview	9
Fixture Installation	10
Understanding DMX	13
Fixture Menu	17
DMX Channel Values	30
Cleaning and Maintenance	32
Technical Specifications	33
Optional Accessories	36
cETLus Approval Mark	37

GENERAL INFORMATION

INTRODUCTION

Congratulations, you have just purchased one of the most innovative and reliable lighting fixtures on the market today! The **LEVEL Q7™** has been designed to perform reliably for years when the guidelines in this booklet are followed. Please read and understand the instructions in this manual carefully and thoroughly before attempting to operate this unit. These instructions contain important information regarding safety during use and maintenance.

UNPACKING

Thank you for purchasing the **LEVEL Q7™** by Elation Professional®. Every **LEVEL Q7™** has been thoroughly tested and has been shipped in perfect operating condition. Carefully check the shipping carton for damage that may have occurred during shipping. If the carton appears to be damaged, carefully inspect your unit for damage and be sure all accessories necessary to operate the unit have arrived intact. In the event damage has been found or parts are missing, please contact our customer support team for further instructions. Please do not return this unit to your dealer without first contacting customer support at the number listed below. Please do not discard the shipping carton in the trash. Please recycle whenever possible.

BOX CONTENTS

- (1) powerCON Power Cable
- (1) 5pin DMX Cable
- (1) Safety Cable
- (1) Gel Frame, Gel Frame Holder, and Frost Filter Gel
- Manual & Warranty Card

CUSTOMER SUPPORT

Elation Professional® provides a customer support line, to provide set up help and to answer any question should you encounter problems during your set up or initial operation. You may also visit us on the web at www.elationlighting.com for any comments or suggestions. For service related issue please contact Elation Professional®.

ELATION SERVICE USA - Monday - Friday 8:00am to 5:00pm PST

Voice: 323-582-3322

Fax: 323-832-9142

E-mail: support@elationlighting.com

ELATION SERVICE EUROPE - Monday - Friday 08:30 to 17:00 CET

Voice: +31 45 546 85 30

Fax: +31 45 546 85 96

E-mail: support@elationlighting.eu

WARRANTY REGISTRATION

The **LEVEL Q7™** carries a two-year (730 days) limited warranty. Please fill out the enclosed warranty card to validate your purchase. All returned service items whether under warranty or not, must be freight pre-paid and accompany a return authorization (R.A.) number. The R.A. number must be clearly written on the outside of the return package. A brief description of the problem as well as the R.A. number must also be written down on a piece of paper and included in the shipping container. If the unit is under warranty, you must provide a copy of your proof of purchase invoice. Items returned without a R.A. number clearly marked on the outside of the package will be refused and returned at customer's expense. You may obtain a R.A. number by contacting customer support at 323-582-3322.



IMPORTANT NOTICE!

There are no user serviceable parts inside this unit. Do not attempt any repairs yourself; doing so will void your manufactures warranty. Damages resulting from modifications to this fixture and/or the disregard of safety and general user instructions found in this user manual void the manufactures warranty and are not subject to any warranty claims and/or repairs.

2 - YEAR LIMITED WARRANTY

A. Elation Professional® hereby warrants, to the original purchaser, Elation Professional® products to be free of manufacturing defects in material and workmanship for a period of two years, (730 days) from the date of purchase. This warranty shall be valid only if the product is purchased within the United States of America, including possessions and territories. It is the owner's responsibility to establish the date and place of purchase by acceptable evidence, at the time service is sought.

B. For warranty service, send the product only to the Elation Professional® factory. All shipping charges must be pre-paid. If the requested repairs or service (including parts replacement) are within the terms of this warranty, Elation Professional® will pay return shipping charges only to a designated point within the United States. If the entire instrument is sent, it must be shipped in its original package. No accessories should be shipped with the product. If any accessories are shipped with the product, Elation Professional® shall have no liability what so ever for loss of or damage to any such accessories, nor for the safe return thereof.

C. This warranty is void if the serial number has been altered or removed; if the product is modified in any manner which Elation Professional® concludes, after inspection, affects the reliability of the product; if the product has been repaired or serviced by anyone other than the Elation Professional® factory unless prior written authorization was issued to purchaser by Elation Professional®; if the product is damaged because not properly maintained as set forth in the instruction manual.

D. This is not a service contract, and this warranty does not include maintenance, cleaning or periodic check-up. During the period specified above, Elation Professional® will replace defective parts at its expense, and will absorb all expenses for warranty service and repair labor by reason of defects in material or workmanship. The sole responsibility of Elation Professional® under this warranty shall be limited to the repair of the product, or replacement thereof, including parts, at the sole discretion of Elation Professional®. All products covered by this warranty were manufactured after January 1, 1990, and bare identifying marks to that effect.

E. Elation Professional® reserves the right to make changes in design and/or improvements upon its products without any obligation to include these changes in any products theretofore manufactured.

F. No warranty, whether expressed or implied, is given or made with respect to any accessory supplied with products described above. Except to the extent prohibited by applicable law, all implied warranties made by Elation Professional® in connection with this product, including warranties of merchantability or fitness, are limited in duration to the warranty period set forth above. And no warranties, whether expressed or implied, including warranties of merchantability or fitness, shall apply to this product after said period has expired. The consumer's and or Dealer's sole remedy shall be such repair or replacement as is expressly provided above; and under no circumstances shall Elation Professional® be liable for any loss or damage, direct or consequential, arising out of the use of, or inability to use, this product.

G. This warranty is the only written warranty applicable to Elation Professional® Products and supersedes all prior warranties and written descriptions of warranty terms and conditions heretofore published.

SAFETY INSTRUCTIONS



The **LEVEL Q7™** is an extremely sophisticated piece of electronic equipment. To guarantee a smooth operation, it is important to follow the guidelines in this manual. The manufacturer of this device will not accept responsibility for damages resulting from the misuse of this fixture due to the disregard of the information printed in this manual.



This device falls under **PROTECTION CLASS 1**. It's essential this device is grounded properly, and only qualified personnel perform all electrical connections.



CAUTION!

Never touch the device during operation!
The housing may heat up



CAUTION!

Never look directly into the light source,
as sensitive persons may suffer an epileptic shock.



CAUTION!

Keep this device away from rain and moisture !



CAUTION!

Unplug mains lead before opening the housing.

- For proper operation, follow the **Installation** guidelines described in this manual. Only qualified and certified personnel should perform installation of this fixture and only the original rigging parts (brackets) included with this fixture should be used for installation. Any modifications will void the original manufacturer's warranty and increase the risk of damage and/or personal injury.
- Never look directly into the light source of this fixture to prevent risk of injury to your retina, which may induce blindness. Those suffering from **EPILEPSY** should avoid looking directly into the light source of this unit at all times.
- The fan and air inlets must remain clean and never blocked. Allow approx. 6" (15cm) between this fixture and other devices or a wall for proper cooling.
- Always disconnect from main power source before performing any type of service and/or cleaning procedure. Only handle the power cord by the plug end, never pull out the plug by tugging the wire portion of the cord.
- Do not operate this fixture if the power cord has become frayed, crimped and/or damaged. If the power cord is damaged, replace it immediately with a new one of similar power rating.

GENERAL GUIDELINES

- **NEVER OPEN THIS FIXTURE WHILE IN USE!**
- During the initial operation of this fixture, a light smoke or smell may emit from the interior of the fixture. This is a normal process and is caused by excess paint in the interior of the casing burning off from the heat associated with the lamp and will decrease gradually over time.
- This fixture is a professional lighting effect designed for **INDOOR / DRY LOCATIONS ONLY** on stage, in nightclubs, theatres, etc.
- Please make sure there are **NO FLAMMABLE MATERIALS** close to the fixture while operating, to prevent any fire hazard.
- **Minimum** distance of inflammable materials from the surface **1.6 feet (0.5m)**.
- The fixture must be installed in a location with adequate ventilation, at least 1.5 feet (.5m) from adjacent surfaces. Be sure no air ventilation slots are blocked.
- **DO NOT** attempt installation and/or operation without knowledge how to do so.
- **DO NOT** allow operation by persons who are not qualified to operate this type of fixture. Most damages are the result of operations by nonprofessionals.
- Consistent operational breaks may ensure the fixture will function properly for many years to come.
- **DO NOT** shake fixture, avoid brute force when installing and/or operating fixture.
- Always install the fixture with an appropriate safety cable. When installing the fixture in a suspended environment, always use mounting hardware that is no less than M10 x 25 mm, also be sure the hardware is insert in the pre-arranged screw holes in the bracket of the fixture.
- Use the original packaging and materials to transport the fixture in for service.
- **DO NOT TOUCH** the housing bare-hand during its operation. Turn OFF the power and allow approximately 15 minutes for the fixture to cool down before replacing or serving.

FIXTURE OVERVIEW

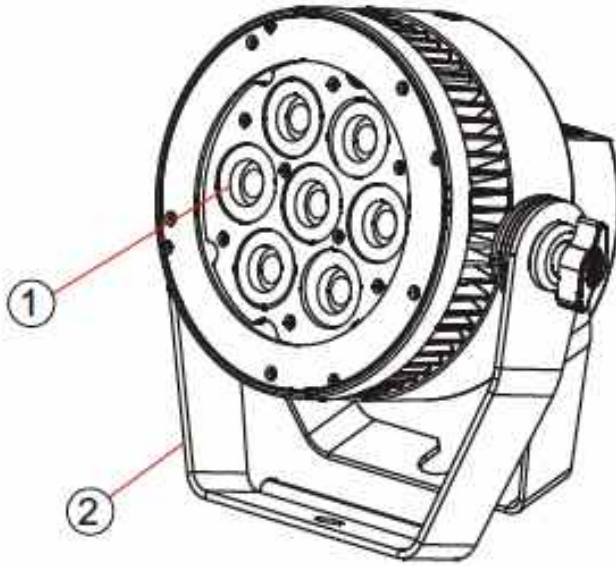

1: LED Lens Assembly

2: Mounting Bracket/Stand

3: 5pin DMX IN

4: powerCON IN

5: LED Menu Control Display

6: MODE/ESC Button

7: UP Button

8: DOWN Button

9: ENTER Button

10: 5pin DMX OUT

11: powerCON OUT

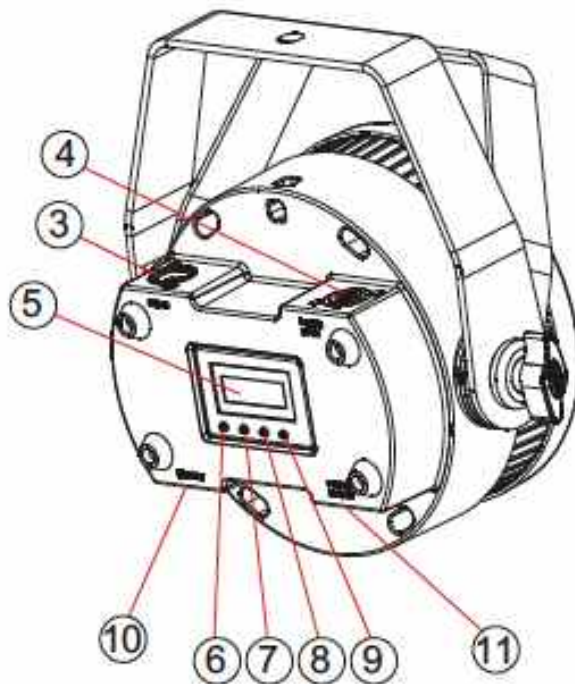

FIXTURE INSTALLATION



CAUTION!

Please consider the GB7000.15/EN60598-2-17 and the other respective national norms during the installation. The installation must only be carried out by a qualified person.



CAUTION!

The electric connection must only be carried out by a qualified electrician.



CAUTIONS

- For added protection, mount the fixture in areas outside walking paths, seating areas, or in areas where unauthorized personnel might reach the fixture.
- Ambient operating temperature range for this fixture is **-13° to 113°F. (-25° to 45°C)**
Do not use the fixture under or above this temperature.
- Before mounting the fixture to any surface, make sure the installation area can hold a minimum point load of 10 times the weight of the fixture. **(90 lbs / 40 kg)**
- Fixture installation must always be secured with a secondary safety attachment, such as an appropriate safety cable.
- Never stand directly below the device when mounting, removing or servicing.

MOUNTING POINTS

- Overhead mounting requires extensive experience, including amongst others calculating working load limits, installation material being used, and periodic safety inspection of all installation material and the device. If you lack these qualifications, do not attempt the installation yourself. Improper installation can result in bodily injury.
- Fixture is fully operational in the specific mounting positions as illustrated below.

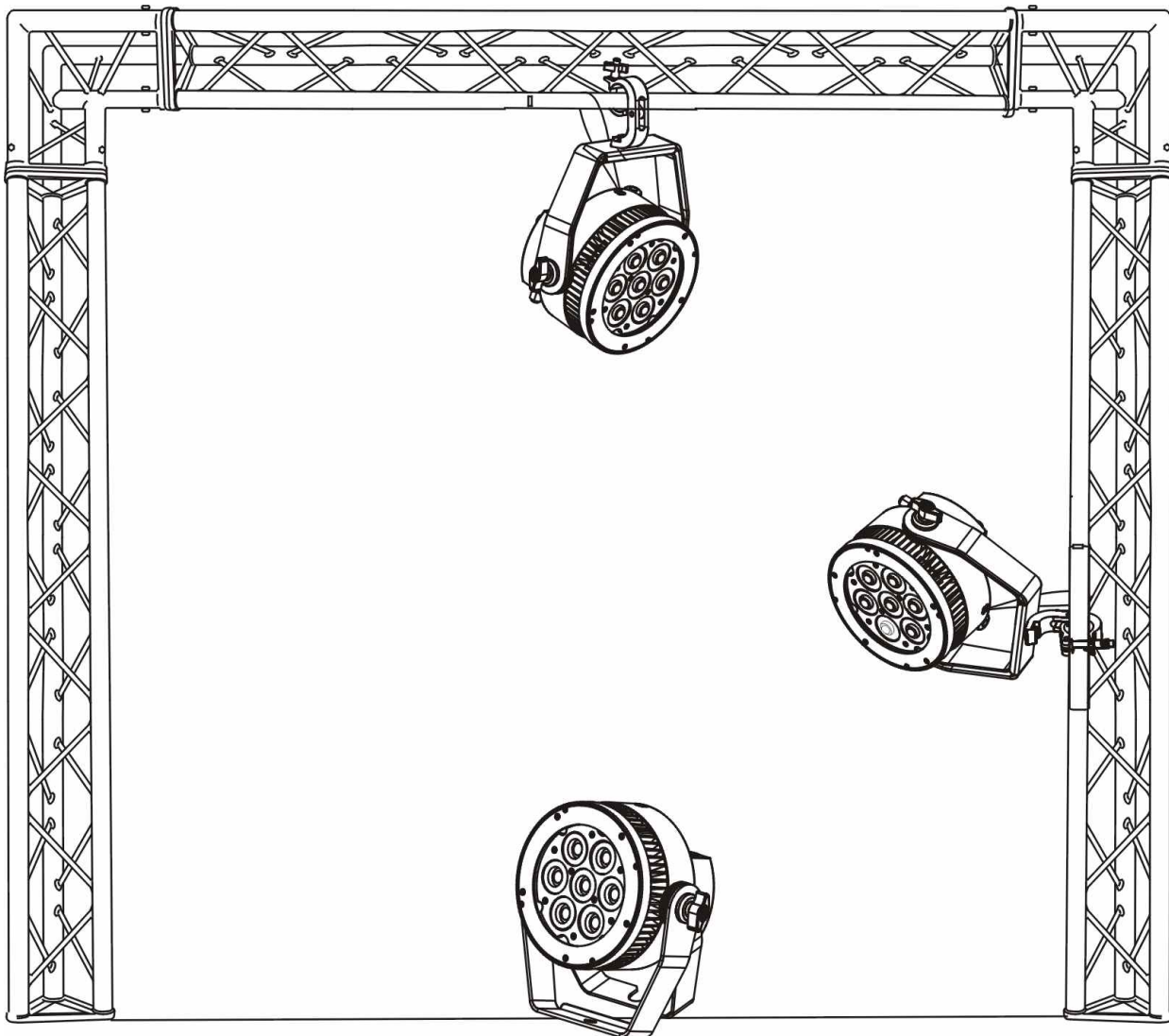

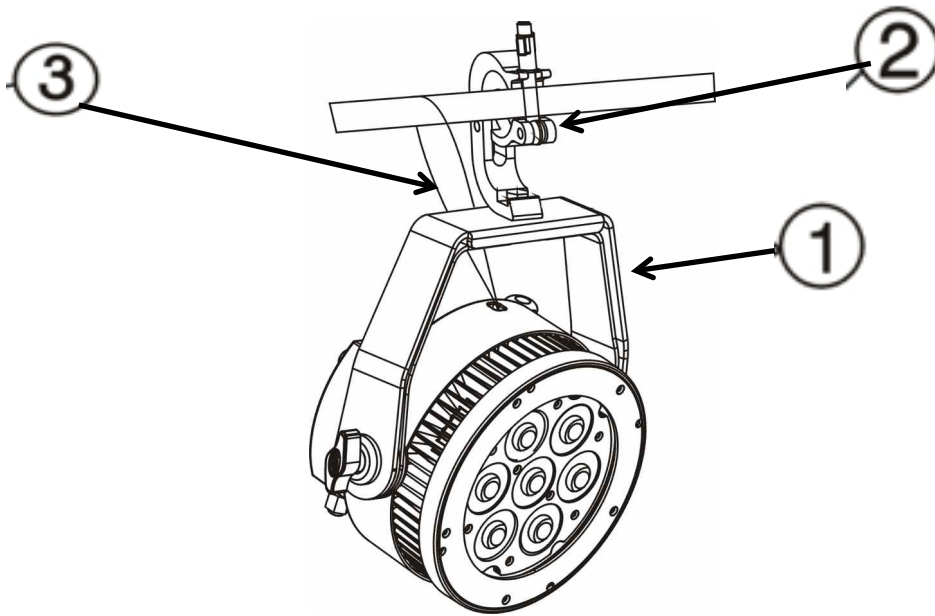

(1) Mounting Bracket / Stand (included)

(2) Clamp (optional)

(3) Safety Cable (included)

INSTALLATION VIA MOUNTING BRACKET / STAND

- Attach a clamp to center $\Phi 13$ hole on the Mounting Bracket using an M12 screw.
- Pull provided Safety Cable through mounting bracket and over the trussing system or a safe installation.

SAFETY CABLE

Always use a Safety Cable whenever installing this fixture in a suspended environment to ensure the fixture will not drop if the clamp fails.

UNDERSTANDING DMX

DMX-512

DMX is short for Digital Multiplex. This is a universal protocol used by most lighting and controller manufactures as a form of communication between intelligent fixtures and controllers. DMX allows all makes and models of different manufactures to be linked together and operate from a single controller. This is possible as long as all the fixtures and the controller are DMX compliant. A DMX controller sends the DMX data instructions to the fixture allowing the user to control the different aspects of an intelligent light. DMX data is sent out as serial data that travels from fixture to fixture via data "IN" and data "OUT" XLR terminals located on the fixtures (most controllers will only have output jacks).

DMX LINKING

To ensure proper DMX data transmission, always use proper DMX cables and a terminator. When using several DMX fixtures try to use the shortest cable path possible. Never split a DMX line with a "Y" style connector. The order in which the fixtures are connected in a DMX line does not influence the DMX addressing. For example; a fixture assigned a starting DMX address of 1 may be placed anywhere in the DMX chain, at the beginning, at the end, or anywhere in the middle. The DMX controller knows to send data assigned to address 1 to that fixture no matter where it is located in the DMX chain. The **LEVEL Q7™** can be controlled via DMX-512 protocol and the DMX address is set via the control menu.

DATA CABLE (DMX Cable) REQUIREMENTS (For DMX and Master/Slave Operation)

Your fixture and your DMX controller require a standard 3pin or 5pin XLR connector for data input and data output (see figure below). If you are making your own cables, be sure to use two conductor, shielded digital DMX cable rated at 120 ohms; this cable is designed for DMX transmission and may be purchased from your Elation dealer or at most professional lighting retailers. Your cables should be made with a male and female XLR connector on either end of the cable. Also, remember that a DMX line must be daisy chained and cannot be split, unless using an approved DMX splitter such as **Elation's Opto Branch 4™, Opto Branch 8™, or DMX-Branch/4™**.

DMX Output
3-Pin XLR Socket



DMX Input
3-Pin XLR Socket



- 1: Ground
- 2: Data (-)
- 3: Data (+)

DMX Output
5-Pin XLR Socket



DMX Input
5-Pin XLR Socket

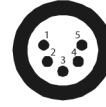

- 1: Ground
- 2: Data (-)
- 3: Data (+)
- 4: Open
- 5: Open



Be sure to follow the above figure when making your own cables. Do not use the ground lug on the XLR connector. Do not connect the cable's shield conductor to the ground lug or allow the shield conductor to come in contact with the XLR outer casing. Grounding the shield could cause a short circuit and erratic behavior.

DMX-512 CONTROLLER CONNECTION

Connect the provided XLR cable to the female XLR output of your controller and the other side to the male XLR input of the **LEVEL Q7™** (Please refer to the diagram below). You can chain multiple panels together through serial linking. The cable that should be used is two conductor, shielded DMX cable with XLR input and output connectors. Always be sure daisy chain your in and out data connections, never split or "Y" your DMX connections unless you are using an approved DMX splitter such as the **Elation's Opto Branch 4™ or DMX Branch/4™**.

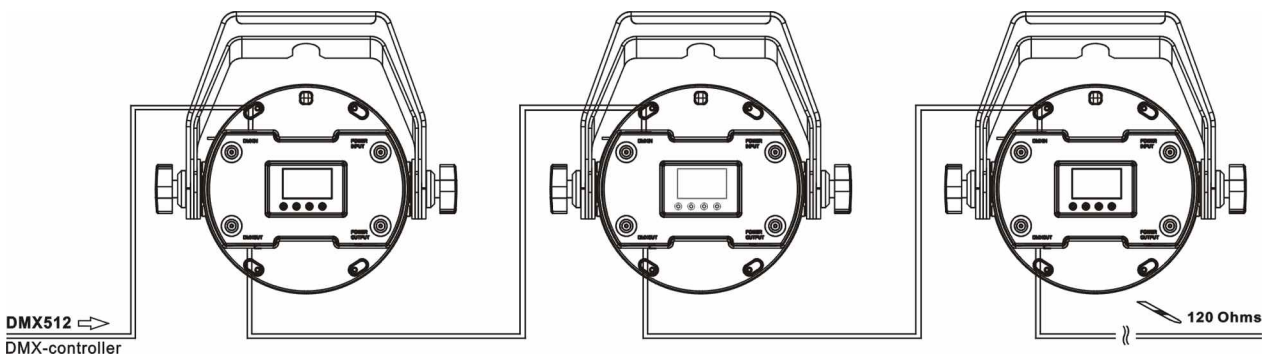

DMX-512 CONNECTION WITH DMX TERMINATOR

A DMX terminator should be used in all DMX lines especially in longer runs. The use of a terminator may avoid erratic behavior in your DMX line. A terminator is a 120 ohm 1/4 watt resistor that is connected between pins 2 and 3 of a male XLR connector (DATA + and DATA -). This fixture is inserted in the female XLR connector of the last fixture in your daisy chain to terminate the line. Using a *line terminator (Elation part: DMX T PACK)* will decrease the possibilities of erratic behavior.

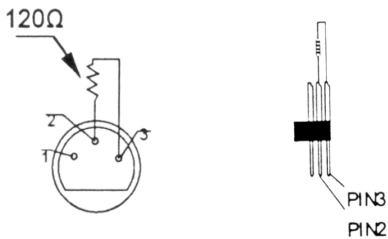

Termination reduces signal errors and avoids signal transmission problems and interference. It is always advisable to connect a DMX terminal, (Resistance 120 Ohm 1/4 W) between PIN 2 (DMX-) and PIN 3 (DMX +) of the last fixture.

5-Pin XLR DMX CONNECTORS

Some manufactures use 5-pin XLR connectors for DATA transmission in place of 3-pin. 5-pin XLR fixtures may be implemented in a 3-pin XLR DMX line. When inserting standard 5-pin XLR connectors in to a 3-pin line a cable adaptor must be used, these adaptors are readily available at most electric stores. The following chart details a proper cable conversion.

3-Pin XLR to 5-Pin XLR Conversion		
Conductor	3-Pin XLR Female (Out)	5-Pin XLR Male (In)
Ground/Shield	Pin 1	Pin 1
Data Compliment (- signal)	Pin 2	Pin 2
Data True (+ signal)	Pin 3	Pin 3
Not Used		Pin 4 - Do Not Use
Not Used		Pin 5 - Do Not Use

DMX ADDRESSING

All fixtures should be given a DMX starting address when using a DMX controller, so the correct fixture responds to the correct control signal. This digital starting address is the channel number from which the fixture starts to “listen” to the digital control information sent out from the DMX controller. The allocation of this starting DMX address is achieved by setting the correct DMX address on the digital display located on the back of the fixture.

You can set the same starting address for all fixtures or a group of fixtures, or set different address for each individual fixture. Be advised that setting all fixtures to the same DMX address will subsequently control all fixtures in the same fashion, in other words, changing the settings of one channel will affect all the fixtures simultaneously.

If you set each fixture to a different DMX address, each unit will start to “listen” to the channel number you have set, based on the quantity of control channels (DMX channels) of each fixture. That means changing the settings of one channel will only affect the selected fixture.

In the case of the **LEVEL Q7™**, when in **17 Channel Mode** (can also be set to 4, 5, 7, or 12 channel modes), you should set the starting DMX address of the first unit to 1, the second unit to 18 (1 + 17), the third unit to 35 (18 + 17), the fourth unit to 52 (35 + 17) and so on.

Note: During start-up the **LEVEL Q7™** will automatically detect whether a DMX data signal is being received or not. If DMX data signal is being received, the display will show "**Addr=XXX**" (**XXX** representing the actual DMX address). If the fixture is not receiving a DMX signal the display will flash. If your fixture is connected to a DMX controller and the display is flashing (not receiving a DMX signal), please check the following:

- The 3pin or 5pin XLR input plug (cable with DMX signal from controller) is not connected or is not inserted completely into the DMX input jack of the fixture.
- The DMX controller is switched off or defective.
- The DMX cable or connector is defective.
- A DMX terminator has been inserted into the last fixture in your DMX chain.

FIXTURE MENU

ON-BOARD SYSTEM MENU

The **LEVEL Q7™** comes with an easy to navigate system menu.

The next section will detail the functions of each command in the system menu.

LED CONTROL PANEL

The **LEVEL Q7™** control panel (see image below) located on back of the fixture offers several features to select from such as setting the DMX address, running pre-programmed macros, changing display options, and resetting the fixture to factory defaults. There are (4) buttons, which are explained below.

[MODE/ESC] Press this button to enter the fixture menus and to return to the previous menu. The display will automatically exit the fixture menus in 10 seconds from the last button press.

[UP] [DOWN] Press these buttons to navigate through the different menu functions and access sub-menu sections.

[ENTER] Press this button to select a menu item and press again to confirm your selection.

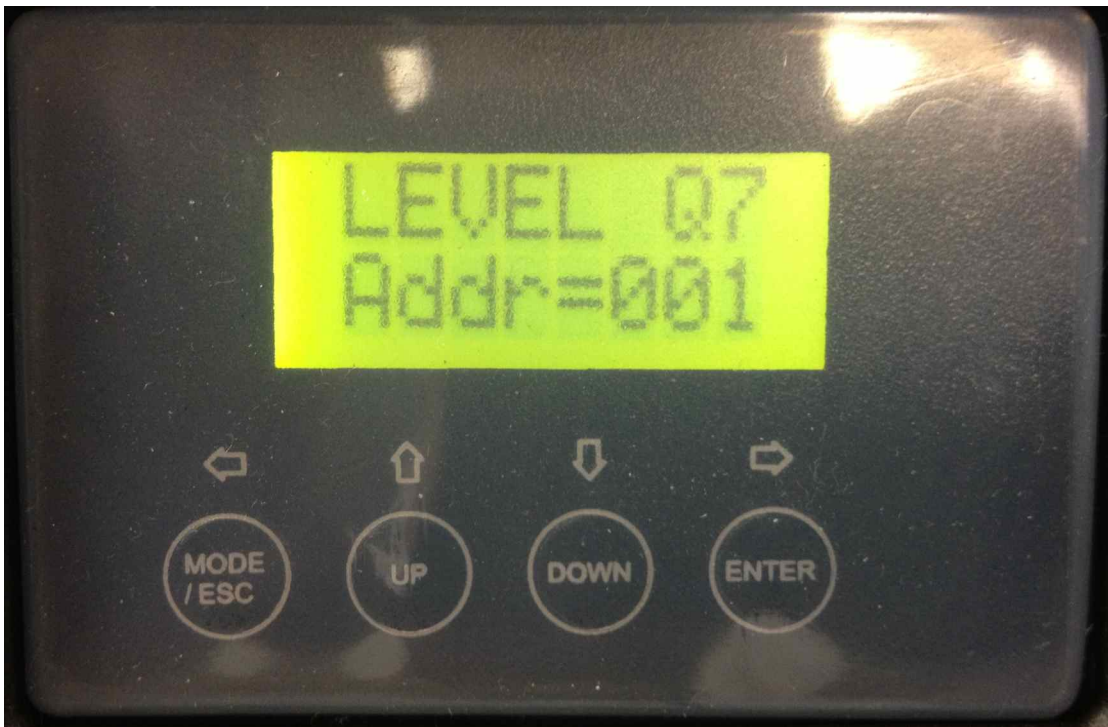

ELATION© LEVEL Q7™ SYSTEM MENU - VERSION 2					
Specifications are subject to change without any prior written notice.					
MAIN MENU	SUB MENU	OPTIONS / VALUES (Default Settings in BOLD)		DESCRIPTION	
FUNC MODE	Set DMX Address	A001~AXXX		DMX Address Setting	
	ValuDisp	Auto.... Red....		DMX Value Display	
	SetSlave	Slave1, Slave2, Slave3		Slave Setting	
	AutoProg	Master / Alone		Auto Program	
INFO	TimeInfo	Cur Time	XXXX(Hours)	Fixture Run Time From Power ON	
		TotalHrs	XXXX(Hours)	Fixture Total Run Time	
		Last Hrs	XXXX(Hours)	Clear Fixture Last Run Time	
		TimePass	Password=XXX	Password 038	
	Clr Last	ON/OFF	Reset Fixture Last Run Time		
	TemplInfo	HeadTemp	XXX C° / F°	Temperature in Fixture Head	
	Soft Ver	V1.0.3		Software Version	
PERSNAL	Stat Set	Addr DMX	ON/OFF	Address Via DMX	
		NoDMXSta	CloShut/Hold/Auto	Auto Run If No DMX	
	Disp Set	Off Time	OFF, 02~59m, 05m	Display Shut Off Time	
		Key Lock	ON/OFF	Display Key Lock	
	Temp C/F	Celsius/ Fahrenheit		Temperature Switch Between C° / F°	
	Man Hold	ON/OFF		Manual Hold	
Reset Def	ON/OFF	Passcode=XXX	Restore ALL Settings To Factory Default (including stored WHITE BALANCE) Passcode 011		
ManCntrl	ManCntrl	Auto, Red, Gree...	Auto = XXX : CIMo = XXX	LED Fine Adjustments	
Mode Set	UserMode	4CH, 5CH, 7CH, 12CH, 17CH		Set DMX Chanel Modes	
Dimming	DimModes	Standar , Stage, TV, Archite, Theatre		Set Dimming Curve Modes	
Edit Prog	Select Prog	Auto Pro Part1 = Program 1~10 (Program 1)		Select Programs To Be Run	
		Auto Pro Part2 = Program 1~10 (Program 2)			
		Auto Pro Part3 = Program 1~10 (Program 3)			
	Edit Prog	Program 1	Program Test		Testing Program
		:	Step 01=SCxxx		Program In Loop
		Program 10	Step 64=SCxxx		Save and Exit
	Edit Scen	Scen001 ~ Scen250	--Fade Time-- --Scene Time--	Manual Scenes Edit	
RecCntrl		XX~XX		Automatic Scenes Recorder	

FuncMode - Address

Adjust the desired DMX-address via the Control Board.

1. Access the main menu by pressing **MODE/ESC**.
2. Press the **UP/DOWN** buttons until "**FuncMode**" is displayed and press **ENTER**.
3. Press the **UP/DOWN** buttons until "**Address**" is displayed and press **ENTER**.
4. Press the **UP/DOWN** buttons to select desired DMX address.
5. Press **ENTER** to confirm selection.

FuncMode - ValuDisp

Display the DMX 512 value of each channel.

1. Access the main menu by pressing **MODE/ESC**.
2. Press the **UP/DOWN** buttons until "**FuncMode**" is displayed and press **ENTER**.
3. Press the **UP/DOWN** buttons until "**ValuDisp**" is displayed and press **ENTER**.
4. Press the **UP/DOWN** buttons to select desired value (**All Ch, Auto, Red, Gree, Blue, Whit, Stro, Dimm, Macr, Temp**).
5. Press **ENTER** to confirm selection.

FuncMode - SetSlave

Define the fixture as slave.

1. Access the main menu by pressing **MODE/ESC**.
2. Press the **UP/DOWN** buttons until "**FuncMode**" is displayed and press **ENTER**.
3. Press the **UP/DOWN** buttons until "**SetSlave**" is displayed and press **ENTER**.
4. Press the **UP/DOWN** buttons to select desired value (**Slave 1, Slave 2, Slave 3**).
5. Press **ENTER** to confirm selection.

FuncMode - AutoProg

Define the fixture mode (**= Master, = Alone**) for running Auto Programs. Select the desired internal programs under "**Sel Prog**", set the number of steps under "**Edit Prog**", and edit the individual scenes under "**Edit Scen**".

1. Access the main menu by pressing **MODE/ESC**.
2. Press the **UP/DOWN** buttons until "**FuncMode**" is displayed and press **ENTER**.
3. Press the **UP/DOWN** buttons until "**AutoProg**" is displayed and press **ENTER**.
4. Press the **UP/DOWN** buttons to select desired value (**=Master, =Alone**).
5. Press **ENTER** to confirm selection.

Info - TimeInfo - Cur Time

Display the run time of the fixture from the last power ON.

The counter is reset after turning the device off.

1. Access the main menu by pressing **MODE/ESC**.
2. Press the **UP/DOWN** buttons until “**Info 2**” is displayed and press **ENTER**.
3. Press the **UP/DOWN** buttons until “**TimeInfo**” is displayed and press **ENTER**.
4. Press the **UP/DOWN** buttons until “**Cur Time**” is displayed and press **ENTER** and the display will show “**XXXh**” (hours).
5. Press **MODE/ESC** to return to previous menu or display will automatically exit.

Info - TimeInfo - TotalHrs

Display the total running time of the fixture.

1. Access the main menu by pressing **MODE/ESC**.
2. Press the **UP/DOWN** buttons until “**Info**” is displayed and press **ENTER**.
3. Press the **UP/DOWN** buttons until “**TimeInfo**” is displayed and press **ENTER**.
4. Press the **UP/DOWN** buttons until “**TotalHrs**” is displayed and press **ENTER** and the display will show “**XXXXXh**” (hours).
5. Press **MODE/ESC** to return to previous menu or display will automatically exit.

Info - TimeInfo - Last Hrs

Display the last the running time of the fixture.

1. Access the main menu by pressing **MODE/ESC**.
2. Press the **UP/DOWN** buttons until “**Info**” is displayed and press **ENTER**.
3. Press the **UP/DOWN** buttons until “**TimeInfo**” is displayed and press **ENTER**.
4. Press the **UP/DOWN** buttons until “**Last Hrs**” is displayed and press **ENTER** and the display will show “**XXXXXh**” (hours).
5. Press **MODE/ESC** to return to previous menu or display will automatically exit.

Info - TimeInfo - TimePass

Enter the timer password. **(038)**.

1. Access the main menu by pressing **MODE/ESC**.
2. Press the **UP/DOWN** buttons until “**Info**” is displayed and press **ENTER**.
3. Press the **UP/DOWN** buttons until “**TimeInfo**” is displayed and press **ENTER**.
4. Press the **UP/DOWN** buttons until “**TimePass**” is displayed and press **ENTER** and the display will show “=**XXX**”.
5. Press **UP/DOWN** buttons until **038** is displayed and press **ENTER**.
6. Press **MODE/ESC** to return to previous menu or display will automatically exit.

Info - TimeInfo - Clr Last

Clear last run time of the fixture, default is **OFF**.

1. Access the main menu by pressing **MODE/ESC**.
2. Press the **UP/DOWN** buttons until “**Info**” is displayed and press **ENTER**.
3. Press the **UP/DOWN** buttons until “**TimeInfo**” is displayed and press **ENTER**.
4. Press the **UP/DOWN** buttons until “**Clr Last**” is displayed and press **ENTER** and the display will show (**=OFF, =ON**).
5. Press the **UP/DOWN** buttons to select (**=OFF or =ON**) and press **ENTER** to clear last run time. **NOTE: A correct password must be entered in the TimePass menu in order to clear last run time.**
6. Press **MODE/ESC** to return to previous menu or display will automatically exit.

Info - TempInfo - HeadTemp

Display the temperature of the fixture, default is **Fahrenheit**.

1. Access the main menu by pressing **MODE/ESC**.
2. Press the **UP/DOWN** buttons until “**Info**” is displayed and press **ENTER**.
3. Press the **UP/DOWN** buttons until “**TempInfo**” is displayed and press **ENTER**.
4. Press the **UP/DOWN** buttons until “**HeadTemp**” is displayed and press **ENTER** and the display will show “=**XXXF**” (degrees) °C / °F.
5. Press **MODE/ESC** to return to previous menu or display will automatically exit.

Info - Soft Ver

Display the software version of the fixture.

1. Access the main menu by pressing **MODE/ESC**.
2. Press the **UP/DOWN** buttons until “**Info**” is displayed and press **ENTER**.
3. Press the **UP/DOWN** buttons until “**Soft Ver**” is displayed and press **ENTER** and the display will show “=**VX.X**”. (software version #)
4. Press **MODE/ESC** to return to previous menu or display will automatically exit.

Persnal - Stat Set - Addr DMX

Adjust the desired DMX address via an external controller, default is **ON**.

1. Access the main menu by pressing **MODE/ESC**.
2. Press the **UP/DOWN** buttons until “**Persnal**” is displayed and press **ENTER**.
3. Press the **UP/DOWN** buttons until “**Stat Set**” is displayed and press **ENTER**.
4. Press the **UP/DOWN** buttons until “**Addr DMX**” is displayed and press **ENTER** and the display will show (**=OFF, =ON**).
5. Press the **UP/DOWN** buttons to select (**=OFF or =ON**) and press **ENTER**.
6. Press **MODE/ESC** to return to previous menu or display will automatically exit.

Persnal - Stat Set - NoDMXSta

Fixture runs in Auto Run if no DMX signal is detected. Options include (**=Hold, =Auto, =CloShut**), default is **=Hold**.

1. Access the main menu by pressing **MODE/ESC**.
2. Press the **UP/DOWN** buttons until “**Persnal**” is displayed and press **ENTER**.
3. Press the **UP/DOWN** buttons until “**Stat Set**” is displayed and press **ENTER**.
4. Press the **UP/DOWN** buttons until “**NoDMXSta**” is displayed and press **ENTER**.
5. Press the **UP/DOWN** buttons to select desired value (**=Hold, =Auto, =CloShut**), and press **ENTER** to confirm selection.
6. Press **MODE/ESC** to return to previous menu or display will automatically exit.

Persnal - Disp Set - Off Time

Shut off the LED display after 02 to 59 minutes, default is **05** minutes.

1. Access the main menu by pressing **MODE/ESC**.
2. Press the **UP/DOWN** buttons until "**Persnal**" is displayed and press **ENTER**.
3. Press the **UP/DOWN** buttons until "**Disp Set**" is displayed and press **ENTER**.
4. Press the **UP/DOWN** buttons until "**Off Time**" is displayed and press **ENTER**.
5. Press the **UP/DOWN** buttons to select desired value (**=OFF, 02-59**), and press **ENTER** to confirm selection.
6. Press **MODE/ESC** to return to previous menu or display will automatically exit.

Persnal - Disp Set - Key Lock

Lock the Control Panel buttons automatically after exiting main menu for 15 seconds. Unlock by keeping the **MODE/ESC** button pressed for 3 seconds. Default is **OFF**.

1. Access the main menu by pressing **MODE/ESC**.
2. Press the **UP/DOWN** buttons until "**Persnal**" is displayed and press **ENTER**.
3. Press the **UP/DOWN** buttons until "**Disp Set**" is displayed and press **ENTER**.
4. Press the **UP/DOWN** buttons until "**Key Lock**" is displayed and press **ENTER**.
5. Press the **UP/DOWN** buttons to select desired value (**=OFF, =ON**), and press **ENTER** to confirm selection.
6. Press **MODE/ESC** to return to previous menu or display will automatically exit.

Persnal - Temp C/F

Display the temperature in Celsius or Fahren, default is **Fahren**.

1. Access the main menu by pressing **MODE/ESC**.
2. Press the **UP/DOWN** buttons until "**Persnal**" is displayed and press **ENTER**.
3. Press the **UP/DOWN** buttons until "**Temp C/F**" is displayed and press **ENTER**.
4. Press the **UP/DOWN** buttons to select desired value (**=Fahren, =Cels**), and press **ENTER** to confirm selection.
5. Press **MODE/ESC** to return to previous menu or display will automatically exit.

Persnal - Man Hold

LED Fine Adjustment

1. Access the main menu by pressing **MODE/ESC**.
2. Press the **UP/DOWN** buttons until "**Persnal**" is displayed and press **ENTER**.
3. Press the **UP/DOWN** buttons until "**Man Hold**" is displayed and press **ENTER**.
4. Press the **UP/DOWN** buttons to select desired value (**=OFF, =ON**), and press **ENTER** to confirm selection.
5. Press **MODE/ESC** to return to previous menu or display will automatically exit.

Persnal - ResetDef **CAUTION - STORED WHITE BALANCE SETTING WILL BE RESET**

Restore factory settings function (**ON or OFF**), the default is **OFF**.

1. Access the main menu by pressing **MODE/ESC**.
2. Press the **UP/DOWN** buttons until "**Persnal**" is displayed and press **ENTER**.
3. Press the **UP/DOWN** buttons until "**ResetDef**" is displayed and press **ENTER**.
4. Press the **UP/DOWN** buttons to select desired value (**=OFF, =ON**), and press **ENTER** to confirm selection.
5. When you select **=ON**, the display will show "**PassCode = 000**", press **UP/DOWN** buttons until **011** is displayed and press **ENTER**.
6. Press **MODE/ESC** to return to previous menu or display will automatically exit.

ManCntrl - ManCntrl

Fine adjustment of all LEDs. All effects will be canceled, and the shutter opens and the dimmer intensity will be set to 100 %. Focus the light on a flat surface or wall and perform the fine adjustments using individual the functions.

1. Access the main menu by pressing **MODE/ESC**.
2. Press the **UP/DOWN** buttons until "**ManCntrl**" is displayed and press **ENTER**.
3. Press the **UP/DOWN** buttons to select desired value (**Auto, Red, RedF, Gree, GreF, Blue, BluF, Whit, WhiF, Stro, Dimm, DimF, Macr, Temp, DiMo, CIEn, CIMo**), and press **ENTER** to confirm selection.
4. Press **UP/DOWN** buttons to select desired value (**000-255**) and press **ENTER** to confirm selection.
5. Press **MODE/ESC** to return to previous menu or display will automatically exit.

Mode Set - UserMode

Select the DMX channel mode (**=4CH, =5CH, =7CH, =12CH, =17CH**), default is **=4CH**.

1. Access the main menu by pressing **MODE/ESC**.
2. Press the **UP/DOWN** buttons until **“Mode Set”** is displayed and press **ENTER**, and press **ENTER** again and **“UserMode”** will display.
3. Press **UP/DOWN** buttons to select desired value (**=4CH, =5CH, =7CH, =12CH, 17CH**), and press **ENTER** to confirm selection.
4. Press **MODE/ESC** to return to previous menu or display will automatically exit.

Dimming - DimModes

Select the dimming curve mode (see diagram below), default is **=Standar**

1. Access the main menu by pressing **MODE/ESC**.
2. Press the **UP/DOWN** buttons until **“Dimming”** is displayed and press **ENTER** and **“DimModes”** will display.
3. Press **UP/DOWN** buttons to select desired value (**=Standar, Stage, TV, Archite, Theatre**), and press **ENTER** to confirm selection.
4. Press **MODE/ESC** to return to previous menu or display will automatically exit.

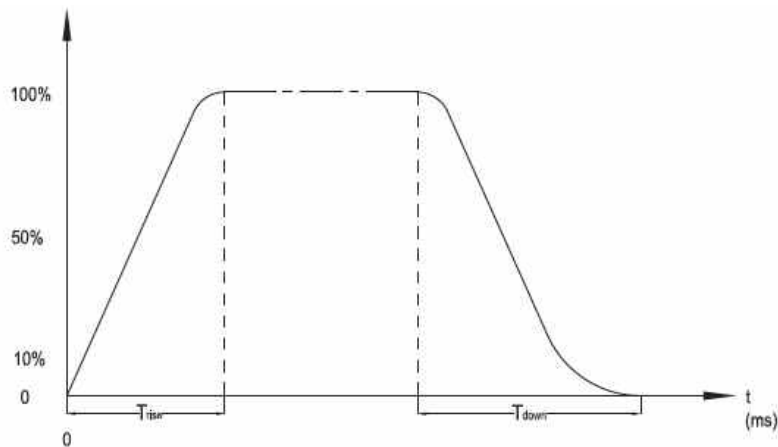

Ramp Effect	0S (Fade Time)		1S (Fade Time)	
	T _{rise} (ms)	T _{down} (ms)	T _{rise} (ms)	T _{down} (ms)
Standard	0	0	0	0
Stage	780	1100	1540	1660
TV	1180	1520	1860	1940
Architectural	1380	1730	2040	2120
Theatre	1580	1940	2230	2280

EditProg - Sel Prog

Select Auto Programs, defaults: ProPart1 = **Prog 1**, ProPart2 = **Prog 2**, ProPart3 = **Prog 3**.

1. Access the main menu by pressing **MODE/ESC**.
2. Press the **UP/DOWN** buttons until "**EditProg**" is displayed and press **ENTER**.
3. Press **UP/DOWN** buttons until "**Sel Prog**" is displayed and press **ENTER**.
4. Press **UP/DOWN** buttons to select desired Auto Program Part (**ProPart1, ProPart2, ProPart3**), and press **ENTER** to confirm selection.
5. Press **UP/DOWN** buttons to select desired Program number (**=Prog 1, =Prog 2, =Prog 3, =Prog 4, =Prog 5, =Prog 6, =Prog 7, =Prog 8, =Prog 9, =Prog 10**), and press **ENTER** to confirm selection.
6. Press **MODE/ESC** to return to previous menu or display will automatically exit.

EditProg - EditProg

Edit the internal programs.

1. Access the main menu by pressing **MODE/ESC**.
2. Press the **UP/DOWN** buttons until "**EditProg**" is displayed and press **ENTER**.
3. Press **UP/DOWN** buttons until "**EditProg**" is displayed and press **ENTER**.
4. Press **UP/DOWN** buttons to select desired Program number (**Prog 1, Prog 2, Prog 3, Prog 4, Prog 5, Prog 6, Prog 7, Prog 8, Prog 9, Prog 10**), and press **ENTER** to confirm selection.
5. Press **UP/DOWN** buttons to select desired Program number (**=Prog 1, =Prog 2, =Prog 3, =Prog 4, =Prog 5, =Prog 6, =Prog 7, =Prog 8, =Prog 9, =Prog 10**), and press **ENTER** to confirm selection.
6. Press **UP/DOWN** buttons to select internal program test or step to edit (**ProgTest, EdStep01-EdStep64**), and press **ENTER** to confirm selection.
7. Press **UP/DOWN** buttons to select desired scene (**SxxSC001-SxxSC250, =End**) [**xx=01-64**], and press **ENTER** to confirm selection.
8. Press **MODE/ESC** to return to previous menu or display will automatically exit.

EditProg - EditScen

Edit the scenes of the internal programs.

1. Access the main menu by pressing **MODE/ESC**.
2. Press the **UP/DOWN** buttons until “**EditProg**” is displayed and press **ENTER**.
3. Press **UP/DOWN** buttons until “**EditScen**” is displayed and press **ENTER**.
4. Press **UP/DOWN** buttons to select desired Scene number (**Scen001-Scen250**), and press **ENTER** to confirm selection.
5. Press **UP/DOWN** buttons to select desired function (**Auto, Red, Gree, Blue, Whit, Stro, Dimm, Macr, Temp, ScenTime, InByOut**), and press **ENTER** to confirm selection.
6. Press **UP/DOWN** buttons to select desired value (**001-250**) and press **ENTER** to confirm selection.
7. Press **MODE/ESC** to return to previous menu or display will automatically exit.

EditProg - RecCntrl

This fixture features an integrated DMX-recorder by which you can transmit the programmed scenes from your DMX-controller to the moving head. Adjust the desired scene numbers via the encoder (from – to). When you call up the scenes at your controller, they will automatically be transmitted to the moving head.

EditProg - RecCntrl - Execution

A Master unit can send up to 3 different data groups to the Slave units, i.e. a Master unit can start 3 different Slave units, which run 3 different programs. The Master unit sends the 3 program parts in a continuous loop.



The Slave unit receives data from the Master unit according to the group which the Slave unit was assigned to. If e.g. a Slave unit is set to “Slave 1” in the menu “Set to Slave”, the Master unit sends “Auto Program Part 1” to the Slave unit. If set to “Slave 2”, the Slave unit receives “Auto Program Part 2”.

EditProg - RecCntrl - Execution [continued]

To start a Auto Program please proceed as follows:

1. Slave-Setting

- Select "Function Mode" by turning the encoder.
- Press the Enter button to confirm.
- Select "Set to slave" by turning the encoder.
- Press the Enter button to confirm.
- Turn the encoder to select "Slave 1", "Slave 2" or "Slave 3".
- Press the Enter button to confirm.
- Press the MODE/ESC button in order to return to the main menu.

2. Automatic Program Run

- Select "Function Mode" by turning the encoder.
- Press the Enter button to confirm.
- Select "Auto Program" by turning the encoder.
- Press the Enter button to confirm.
- Turn the encoder to select "Master" or "Alone". The selection "Alone" means Stand Alone-mode and "Master" that the device is defined as master.
- Press the Enter button to confirm.
- Press the MODE/ESC button in order to return to the main menu.

3. Program selection for Auto Pro Part

- Select "Edit program" by turning the encoder.
- Press the Enter button to confirm.
- Select "Select programs" by turning the encoder.
- Press the Enter button to confirm.
- Turn the encoder to select "Auto Pro Part 1", "Auto Pro Part 2" or "Auto Pro Part 3", and thus select which Slave program is to be sent. Selection "Part 1" means, that the Slave unit runs the same program as the master units.
- Press the Enter button to confirm.
- Press the MODE/ESC button in order to return to the main menu.

4. Program selection for Edit Program

- Select "Edit program" by turning the encoder.
- Press the Enter button to confirm.
- Select "Edit program" by turning the encoder.
- Press the Enter button to confirm.
- Turn the encoder to select the desired program. With this function you can edit specific scenes into a specific program.
- Press the Enter button to confirm.
- Press the MODE/ESC button in order to return to the main menu.

5. Automatic Scene Recording

- Select "Edit program" by turning the encoder.
- Press the Enter button to confirm.
- Select "Edit scenes" by turning the encoder.
- Turn the encoder to select the desired scene numbers, you can program a max number of 250
- Press the Enter button to confirm.
- Press the MODE/ESC button in order to return to the main menu.

EditProg - RecCntrl - Execution [continued]

Example:

Program 2 includes scenes: 10, 11, 12, 13

Program 4 includes scenes: 8, 9, 10

Program 6 includes scenes: 12, 13, 14, 15

Auto Pro Part 1 is Program 2;

Auto Pro Part 2 is Program 3;

Auto Pro Part 3 is Program 6

The 3 Slave groups run the Auto Program in certain time segments, as shown in the following picture:

Part 1:

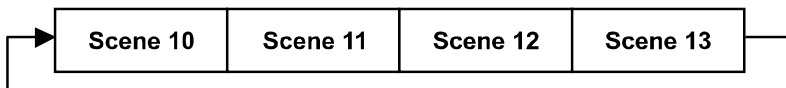

Part 2:

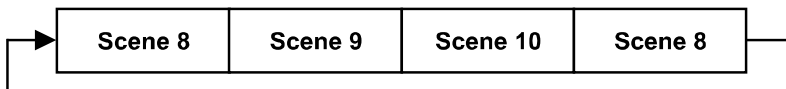

Part 3:

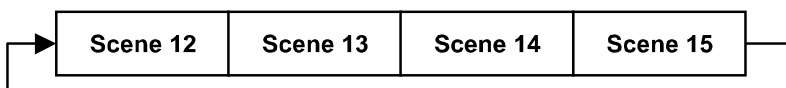

DMX CHANNEL FUNCTIONS AND VALUES

ELATION® LEVEL Q7™						
DMX Channel Values / Functions - VERSION 2 (17 DMX Channels)						
Specifications are subject to change without any prior written notice.						
MODE / CHANNEL					VALUE	FUNCTION
4CH	5CH	7CH	12CH	17CH		
1	1	1	1	1		RED [ALL LEDs]
					0-255	(0-Black , 255-100% RED)
				2		RED FINE ADJUSTMENT [ALL LEDs]
					0-255	RED Fine Adjustment
2	2	2	2	3		GREEN [ALL LEDs]
					0-255	(0-Black , 255-100% GREEN)
				4		GREEN FINE ADJUSTMENT [ALL LEDs]
					0-255	GREEN Fine Adjustment
3	3	3	3	5		BLUE [ALL LEDs]
					0-255	(0-Black , 255-100% BLUE)
				6		BLUE FINE ADJUSTMENT [ALL LEDs]
					0-255	BLUE Fine Adjustment
4	4	4	4	7		WHITE [ALL LEDs]
					0-255	(0-Black , 255-100% WHITE)
				8		WHITE FINE ADJUSTMENT [ALL LEDs]
					0-255	WHITE Fine Adjustment
		5	5	9		COLOR CORRECTION [ALL LEDs]
					0	NO Function
					1-255	(1-2,700K, 255-7,200K)
				10		COLORS
					0	NO Function
					1-7	Color Macro 1
					8-15	Color Macro 2
					16-23	Color Macro 3
					24-31	Color Macro 4
					32-39	Color Macro 5
					40-47	Color Macro 6
					48-55	Color Macro 7
					56-63	Color Macro 8
					64-71	Color Macro 9
					72-79	Color Macro 10
					80-87	Color Macro 11
					88-95	Color Macro 12
					96-103	Color Macro 13
					104-111	Color Macro 14
					112-119	Color Macro 15
					120-127	Color Macro 16
					128-135	Color Macro 17
					136-143	Color Macro 18
					144-151	Color Macro 19
					152-159	Color Macro 20
					160-167	Color Macro 21
					168-175	Color Macro 22
					176-183	Color Macro 23
					184-191	Color Macro 24
					192-199	Color Macro 25
					200-207	Color Macro 26
					208-215	Color Macro 27
					216-223	Color Macro 28
					224-231	Color Macro 29
					232-239	Color Macro 30
240-247	Color Macro 31					
248-255	Color Macro 32					

ELATION® LEVEL Q7™					
DMX Channel Values / Functions - VERSION 2 (17 DMX Channels)					
Specifications are subject to change without any prior written notice.					
MODE / CHANNEL					
4CH	5CH	7CH	12CH	17CH	
VALUE					
FUNCTION					
			7	11	INTERNAL PROGRAM MACROS
					0 NO Function
					1-30 Internal Program Macro 1
					31-60 Internal Program Macro 2
					61-90 Internal Program Macro 3
					91-120 Internal Program Macro 4
					121-150 Internal Program Macro 5
					151-180 Internal Program Macro 6
					181-210 Internal Program Macro 7
					211-255 Internal Program Macro 8
			8	12	SHUTTER, STROBE
					0-31 LEDs OFF
					32-63 LEDs ON
					64-95 STROBE Effect SLOW to FAST
					96-127 LEDs ON
					128-159 Pulse Effect in Sequences
					160-191 LEDs ON
					192-223 Random STROBE Effect SLOW to FAST
					224-255 LEDs ON
	5	7	9	13	DIMMER INTENSITY / INTERNAL PROGRAM MACRO SPEED*
					Dimmer Intensity 0 to 100% / Speed SLOW to FAST
					*Only When Internal Program Macro is used in 12CH and 17CH modes
				14	DIMMER INTENSITY FINE
					0-255 Dimmer Intensity FINE Adjustment
			10	15	DIMMING MODES
					0-20 STANDARD
					21-40 STAGE
					41-60 TV
					61-80 ARCHITECTURAL
					81-100 THEATRE
					101-255 Default to Unit Setting
			11	16	COLOR ENABLE
					0-189 NO Function
					190-255 Enable (Turn ON) EDIT WHITE BALANCE Mode
			12	17	COLOR MODE
					0-190 NO Function
					190-254 EDIT (Set) a New WHITE BALANCE
					255 STORE (Save) a New WHITE BALANCE

CLEANING AND MAINTENANCE



CAUTION!

Disconnect from mains before starting maintenance operation.

CLEANING

Frequent cleaning is recommended to insure proper function, optimized light output, and an extended life. The frequency of cleaning depends on the environment in which the fixture operates: damp, smoky or particularly dirty environments can cause greater accumulation of dirt on the fixture's optics.

- Clean the external lens surface at least every 20 days with a soft cloth to avoid dirt/debris accumulation. Never use alcohol, solvents, or ammonia based cleaners.

MAINTENANCE

Regular inspections are recommended to insure proper function and extended life. There are no user serviceable parts inside this fixture, please refer all other service issues to an authorized Elation service technician. Should you need any spare parts, please order genuine parts from your local Elation dealer.

Please refer to the following points during routine inspections:

- A detailed electric check by an approved electrical engineer every 3 months, to make sure the circuit contacts are in good condition and prevent overheating.
- Be sure all screws and fasteners are securely tightened at all times. Loose screws may fall out during normal operation resulting in damage or injury.
- Check for any deformations on the housing, color lenses, rigging hardware and rigging points (ceiling, suspension, trussing). Deformations in the housing could allow for dust to enter into the fixture. Damaged rigging points or unsecured rigging could cause the fixture to fall and seriously injure a person(s).
- Inspect all moving parts and make sure there are no signs of wear and rotate/move without imbalances.
- Electric power supply cables must not show any damage, material fatigue or sediments. Never remove the ground prong from the power cable.

TECHNICAL SPECIFICATIONS

FEATURES

7° Beam 13° Field Angles
2,700K - 7,200K Color Correction
Variable Dimming Curves
Flicker Free Operation for TV and FILM
Rugged Die-Cast Aluminum Exterior
Rubber Padded Base with Dual Yoke / Floor Stand
Multiple Unit Power Linking
Gel Frame, Frost Filter, and Holder Included

SOURCE

(7) 15W QUAD Color RGBW LEDs
100,000 Hour Average Life*
*May vary depending on several factors including but not limited to:
Environmental Conditions, Power/Voltage, Usage Patterns (On-Off Cycling), Control, and Dimming.

PHOTOMETRIC DATA

3636 LUX 388 FC @16.4' (5M)

EFFECTS

Electronic Strobe and Varying Settings
Color and Chase Macros
Electronic Dimming: 0% - 100%

CONTROL / CONNECTIONS

(5) DMX Channel Modes (4 / 5 / 7 / 12 / 17)
(4) Button Control Panel
LCD Menu Display
5pin DMX In/Out
powerCON In/Out

SIZE / WEIGHT

Length: 11.0" (278.6mm)
Width: 5.5" (140.5mm)
Vertical Height: 10.2" (260mm)
Weight: 9.0 lbs. (4 kg)

ELECTRICAL / THERMAL

AC 100-240V - 50/60Hz
127W Max Power Consumption
Multiple Unit Power Linking
-13°F to 113°F (-25°C to 45°C)

APPROVALS / RATINGS

CE Approved
cETLus Approved
IP20 Rated

INSTALLATION

Rigging: Integrated Dual Yoke / Floor Stand
Working Position: Any (360°)

Please Note: Specifications and improvements in the design of this unit and this manual are subject to change without any prior written notice.

PHOTOMETRIC DATA

RED LEDs	190 FC / 2046 LUX	43 FC / 467 LUX	19 FC / 200 LUX
GREEN LEDs	596 FC / 6420 LUX	145 FC / 1565 LUX	64 FC / 693 LUX
BLUE LEDs	88 FC / 950 LUX	23 FC / 249 LUX	10 FC / 113 LUX
WHITE LEDs	695 FC / 7485 LUX	176 FC / 1890 LUX	79 FC / 850 LUX
FULL ON	1366 FC / 14,700 LUX	338 FC / 3636 LUX	149 FC / 1601 LUX

LUX x 0.0929 = FC

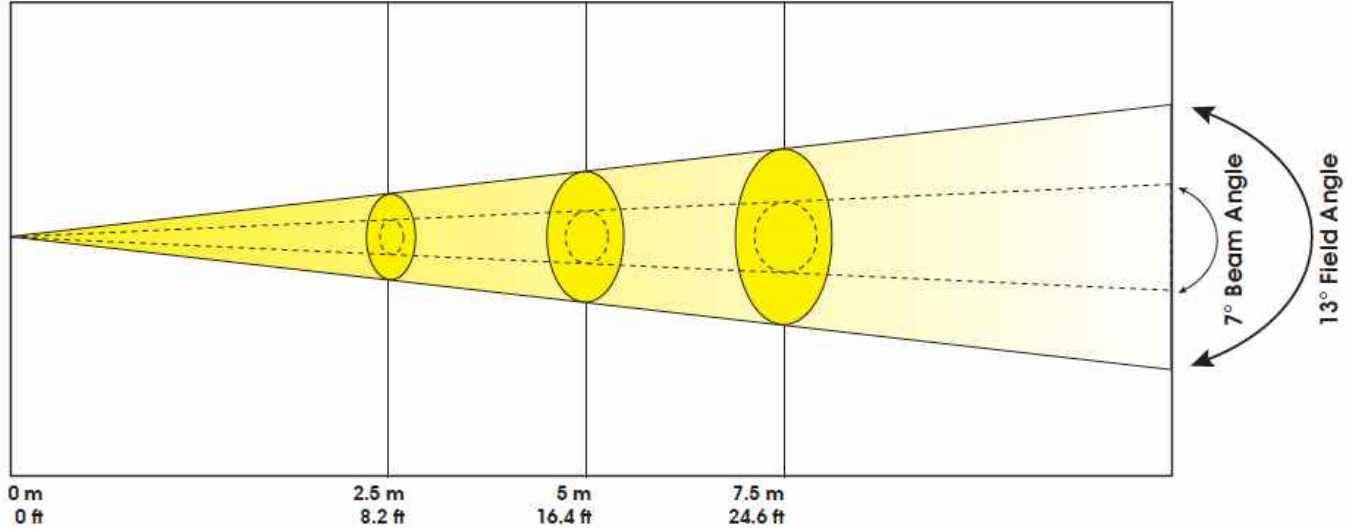

7° Beam Angle	Ø 0.32 m / Ø 1.0 ft	Ø 0.62 m / Ø 2.0 ft	Ø 0.92 m / Ø 3.0 ft
13° Field Angle	Ø 0.57 m / Ø 1.9 ft	Ø 1.12 m / Ø 3.7 ft	Ø 1.66 m / Ø 5.4 ft

DIMENSIONAL DRAWINGS

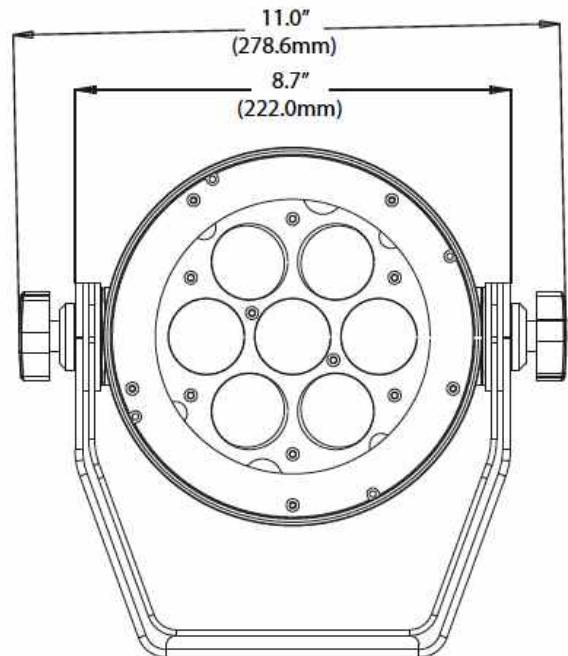
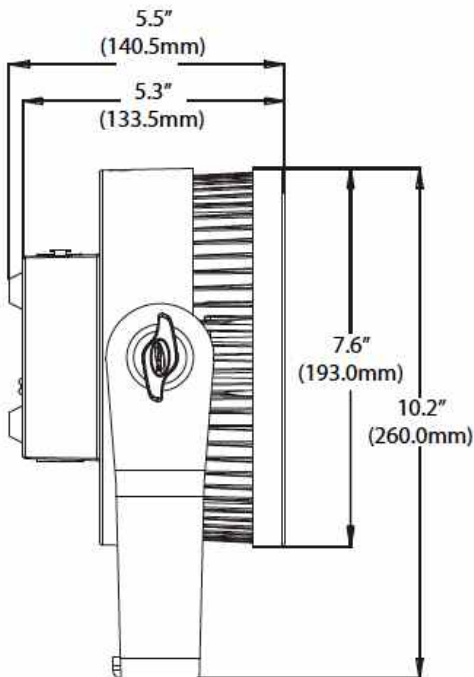

Please Note: Specifications and improvements in the design of this unit and this manual are subject to change without any prior written notice.

CIRCUIT SCHEMATIC

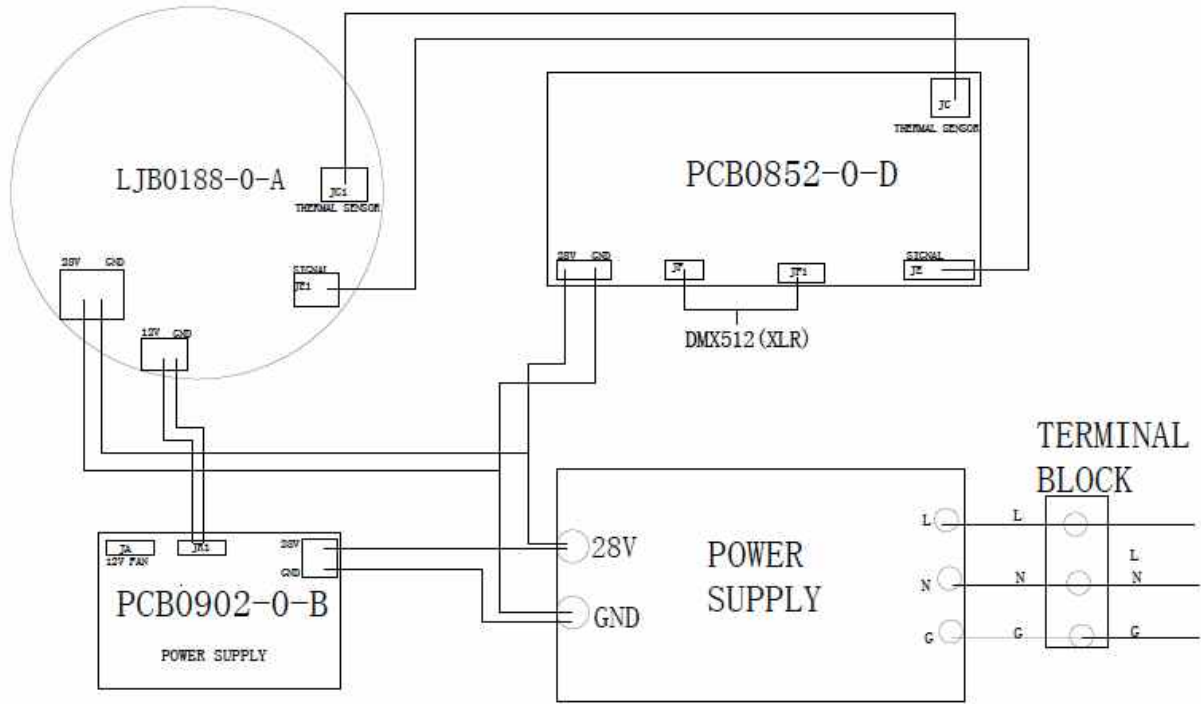

Please Note: Specifications and improvements in the design of this unit and this manual are subject to change without any prior written notice.

OPTIONAL ACCESSORIES

ORDER CODE	ITEM
NARROW CLAMP	2" Pro Wrap Around Clamp
AC5PDMX5PRO	5 ft. (1.5m) 5pin PRO DMX Cable
AC5PDMX10PRO	10 ft. (3m) 5pin PRO DMX Cable
AC5PDMX15PRO	15 ft. (4.5m) 5pin PRO DMX Cable
AC5PDMX25PRO	25 ft. (7.5m) 5pin PRO DMX Cable
AC5PDMX50PRO	50 ft. (15m) 5pin PRO DMX Cable
AC5PDMX100PRO	100 ft. (30m) 5pin PRO DMX Cable
PLC3	3' (1m) PowerCON PRO Link Cable
PLC6	6' (1.8m) PowerCON PRO Link Cable
PLC10	10' (3m) PowerCON PRO Link Cable
PLC15	15' (4.5m) PowerCON PRO Link Cable
LEV054-GFH	Gel Frame Holder Kit (7.88" Slot Holder, Gel Frame, and (4) Screws)
LEV054-GFH-S4	Source 4 Accessory Holder (7.50" Slot Holder and (4) Screws)
LSF536	Light Shaping Filter 30° 20" x 24" Sheet
LSF537	Light Shaping Filter 20° 20" x 22" Sheet
LSF538	Light Shaping Filter 60° x 1° 20" x 24" Sheet
LSF559	Light Shaping Filter 10° 20" x 24" Sheet

	<p>Model: LEVEL 7Q CONFORMS TO UL STD. 1598 CERTIFIED TO CSA STD. C22.2 NO. 250.0 100-240V~,50/60Hz; 120W MAX; MANUFACTURING DATE: _____</p>
<p>Intertek 3104374</p>	<p>WARNING</p> <ul style="list-style-type: none">• Dry Locations Only• Pour Emplacements Secs Seulemen

