



# OPTI QA PAR™

user manual

©2014 ELATION PROFESSIONAL all rights reserved. Information, specifications, diagrams, images, and instructions herein are subject to change without notice. ELATION PROFESSIONAL logo and identifying product names and numbers herein are trademarks of ELATION PROFESSIONAL. Copyright protection claimed includes all forms and matters of copyrightable materials and information now allowed by statutory or judicial law or hereinafter granted. Product names used in this document may be trademarks or registered trademarks of their respective companies and are hereby acknowledged. All non-ELATION brands and product names are trademarks or registered trademarks of their respective companies.

**ELATION PROFESSIONAL** and all affiliated companies hereby disclaim any and all liabilities for property, equipment, building, and electrical damages, injuries to any persons, and direct or indirect economic loss associated with the use or reliance of any information contained within this document, and/or as a result of the improper, unsafe, insufficient and negligent assembly, installation, rigging, and operation of this product.

**Elation Professional USA** | 6122 S. Eastern Ave. | Los Angeles, CA. 90040  
323-582-3322 | 323-832-9142 fax | [www.elationlighting.com](http://www.elationlighting.com) | [info@elationlighting.com](mailto:info@elationlighting.com)

**Elation Professional B.V.** | Junostraat 2 | 6468 EW Kerkrade, Netherlands  
+31 45 546 85 66 | +31 45 546 85 96 fax | [www.elationlighting.eu](http://www.elationlighting.eu) | [info@elationlighting.eu](mailto:info@elationlighting.eu)

## DOCUMENT VERSION



Please check [www.elationlighting.com](http://www.elationlighting.com) for the latest revision/update of this manual.

Date	Document Version	Software Version	DMX Channel Modes	Notes
8/2014	2	≥1.5	1/3/5/6/8/9	Added dimming curve modes and additional Color Macros.

# CONTENTS

General Information	4
Warranty	6
Safety Instructions	7
General Guidelines	8
Fixture Overview	9
Fixture Installation	10
Understanding DMX	12
Fixture Menu	16
Dimming Curves	18
DMX Channel Functions And Values	19
Cleaning and Maintenance	22
Technical Specifications	23
Optional Accessories	25

## GENERAL INFORMATION

### INTRODUCTION

Congratulations, you have just purchased one of the most innovative and reliable lighting fixtures on the market today! The **OPTI QA PAR™** has been designed to perform reliably for years when the guidelines in this booklet are followed. Please read and understand the instructions in this manual carefully and thoroughly before attempting to operate this unit. These instructions contain important information regarding safety during use and maintenance.

### UNPACKING

Thank you for purchasing the **OPTI QA PAR™** by Elation Professional®. Every **OPTI QA PAR™** has been thoroughly tested and has been shipped in perfect operating condition. Carefully check the shipping carton for damage that may have occurred during shipping. If the carton appears to be damaged, carefully inspect your unit for damage and be sure all accessories necessary to operate the unit have arrived intact. In the event damage has been found or parts are missing, please contact our customer support team for further instructions. Please do not return this unit to your dealer without first contacting customer support at the number listed below. Please do not discard the shipping carton in the trash. Please recycle whenever possible.

### BOX CONTENTS

- (1) Gel Frame
- (1) powerCON Cable
- Manual & Warranty Card

## CUSTOMER SUPPORT

Elation Professional® provides a customer support line, to provide set up help and to answer any question should you encounter problems during your set up or initial operation. You may also visit us on the web at [www.elationlighting.com](http://www.elationlighting.com) for any comments or suggestions. For service related issue please contact Elation Professional®.

### ELATION SERVICE USA - Monday - Friday 8:00am to 5:00pm PST

Voice: 323-582-3322

Fax: 323-832-9142

E-mail: [support@elationlighting.com](mailto:support@elationlighting.com)

### ELATION SERVICE EUROPE - Monday - Friday 08:30 to 17:00 CET

Voice: +31 45 546 85 30

Fax: +31 45 546 85 96

E-mail: [support@elationlighting.eu](mailto:support@elationlighting.eu)

## WARRANTY REGISTRATION

The **OPTI QA PAR™** carries a two-year (730 days) limited warranty. Please fill out the enclosed warranty card to validate your purchase. All returned service items whether under warranty or not, must be freight pre-paid and accompany a return authorization (R.A.) number. The R.A. number must be clearly written on the outside of the return package. A brief description of the problem as well as the R.A. number must also be written down on a piece of paper and included in the shipping container. If the unit is under warranty, you must provide a copy of your proof of purchase invoice. Items returned without a R.A. number clearly marked on the outside of the package will be refused and returned at customer's expense. You may obtain a R.A. number by contacting customer support at 323-582-3322.



## **IMPORTANT NOTICE!**

**There are no user serviceable parts inside this unit. Do not attempt any repairs yourself; doing so will void your manufactures warranty. Damages resulting from modifications to this fixture and/or the disregard of safety and general user instructions found in this user manual void the manufactures warranty and are not subject to any warranty claims and/or repairs.**

## 2 - YEAR LIMITED WARRANTY

A. Elation Professional® hereby warrants, to the original purchaser, Elation Professional® products to be free of manufacturing defects in material and workmanship for a period of two years, (730 days) from the date of purchase. This warranty shall be valid only if the product is purchased within the United States of America, including possessions and territories. It is the owner's responsibility to establish the date and place of purchase by acceptable evidence, at the time service is sought.

B. For warranty service, send the product only to the Elation Professional® factory. All shipping charges must be pre-paid. If the requested repairs or service (including parts replacement) are within the terms of this warranty, Elation Professional® will pay return shipping charges only to a designated point within the United States. If the entire instrument is sent, it must be shipped in its original package. No accessories should be shipped with the product. If any accessories are shipped with the product, Elation Professional® shall have no liability what so ever for loss of or damage to any such accessories, nor for the safe return thereof.

C. This warranty is void if the serial number has been altered or removed; if the product is modified in any manner which Elation Professional® concludes, after inspection, affects the reliability of the product; if the product has been repaired or serviced by anyone other than the Elation Professional® factory unless prior written authorization was issued to purchaser by Elation Professional®; if the product is damaged because not properly maintained as set forth in the instruction manual.

D. This is not a service contract, and this warranty does not include maintenance, cleaning or periodic check-up. During the period specified above, Elation Professional® will replace defective parts at its expense, and will absorb all expenses for warranty service and repair labor by reason of defects in material or workmanship. The sole responsibility of Elation Professional® under this warranty shall be limited to the repair of the product, or replacement thereof, including parts, at the sole discretion of Elation Professional®. All products covered by this warranty were manufactured after January 1, 1990, and bare identifying marks to that effect.

E. Elation Professional® reserves the right to make changes in design and/or improvements upon its products without any obligation to include these changes in any products theretofore manufactured.

F. No warranty, whether expressed or implied, is given or made with respect to any accessory supplied with products described above. Except to the extent prohibited by applicable law, all implied warranties made by Elation Professional® in connection with this product, including warranties of merchantability or fitness, are limited in duration to the warranty period set forth above. And no warranties, whether expressed or implied, including warranties of merchantability or fitness, shall apply to this product after said period has expired. The consumer's and or Dealer's sole remedy shall be such repair or replacement as is expressly provided above; and under no circumstances shall Elation Professional® be liable for any loss or damage, direct or consequential, arising out of the use of, or inability to use, this product.

G. This warranty is the only written warranty applicable to Elation Professional® Products and supersedes all prior warranties and written descriptions of warranty terms and conditions heretofore published.

## SAFETY INSTRUCTIONS



The **OPTI QA PAR™** is an extremely sophisticated piece of electronic equipment. To guarantee a smooth operation, it is important to follow the guidelines in this manual. The manufacturer of this device will not accept responsibility for damages resulting from the misuse of this fixture due to the disregard of the information printed in this manual.



This device falls under **PROTECTION CLASS 1**. It's essential this device be grounded properly. Only qualified personnel should perform all electrical connections.



### CAUTION!

Keep this device away from rain and moisture !



### CAUTION!

Unplug mains lead before opening the housing.



### CAUTION!

Never touch the device during operation!  
The housing may heat up



### CAUTION!

Never look directly into the light source,  
as sensitive persons may suffer an epileptic shock.

- For proper operation, follow the **Installation** guidelines described in this manual. Only qualified and certified personnel should perform installation of this fixture and only the original rigging parts (brackets) included with this fixture should be used for installation. Any modifications will void the original manufactures warranty and increase the risk of damage and/or personal injury.
- Never look directly into the light source of this fixture to prevent risk of injury to your retina, which may induce blindness. Those suffering from **EPILEPSY** should avoid looking directly into the light source of this unit at all times.
- Always disconnect from main power source before performing any type of service and/or cleaning procedure. Only handle the power cord by the plug end, never pull out the plug by tugging the wire portion of the cord.
- Do not operate this fixture if the power cord has become frayed, crimped and/or damaged. If the power cord is damaged, replace it immediately with a new one of similar power rating.

## GENERAL GUIDELINES

- **NEVER OPEN THIS FIXTURE WHILE IN USE!**
- During the initial operation of this fixture, a light smoke or smell may emit from the interior of the fixture. This is a normal process and is caused by excess paint in the interior of the casing burning off from the heat associated with the lamp and will decrease gradually over time.
- This fixture is a professional lighting effect designed for **INDOOR / DRY LOCATIONS ONLY** on stage, in nightclubs, theatres, etc.
- Please make sure there are **NO FLAMMABLE MATERIALS** close to the fixture while operating, to prevent any fire hazard.
- **Minimum** distance of inflammable materials from the surface **1.6 feet (0.5m)**.
- **DO NOT** attempt installation and/or operation without knowledge how to do so.
- **DO NOT** allow operation by persons who are not qualified to operate this type of fixture. Most damages are the result of operations by nonprofessionals.
- Consistent operational breaks may ensure the fixture will function properly for many years to come.
- **DO NOT** shake fixture, avoid brute force when installing and/or operating fixture.
- Always install the fixture with an appropriate safety cable. When installing the fixture in a suspended environment, always use mounting hardware that is no less than M10 x 25 mm, also be sure the hardware is insert in the pre-arranged screw holes in the bracket of the fixture.
- Use the original packaging and materials to transport the fixture in for service.
- **DO NOT TOUCH** the housing bare-hand during its operation. Turn OFF the power and allow approximately 15 minutes for the fixture to cool down before replacing or serving.



## FIXTURE OVERVIEW

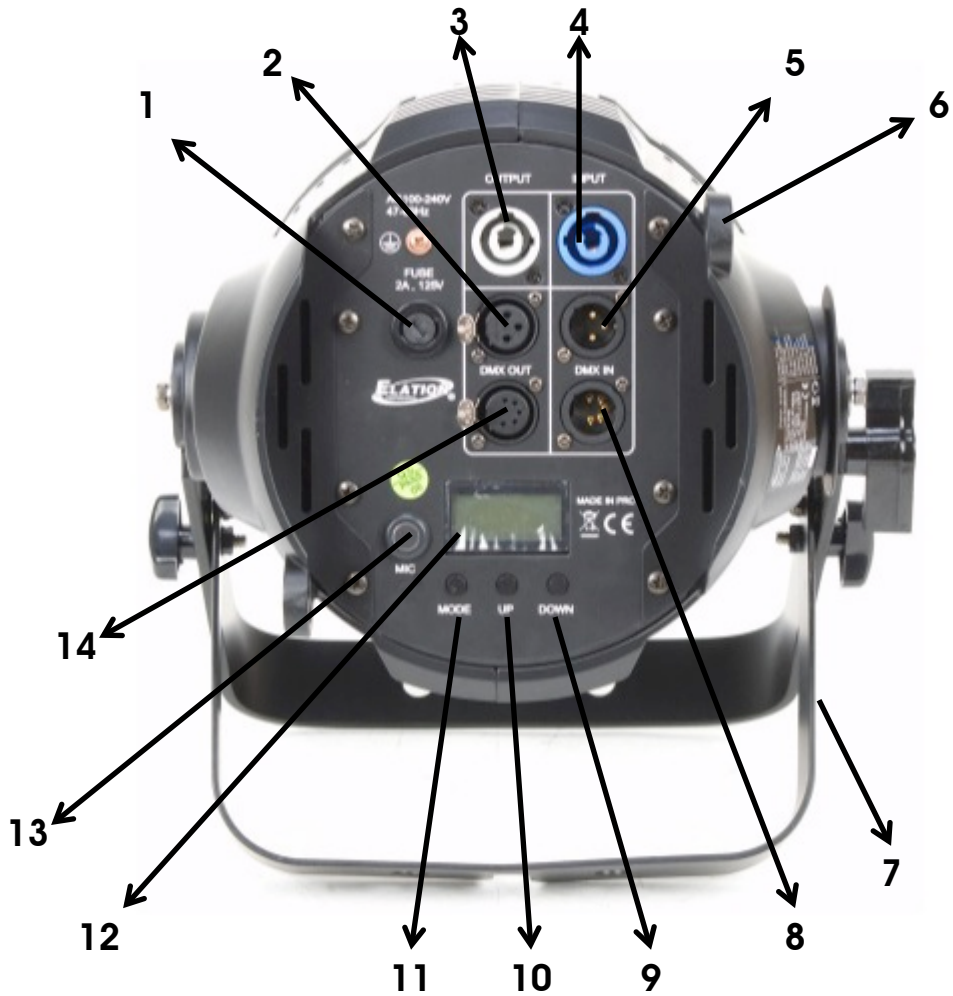

1. FUSE
2. 3pin DMX OUT
3. powerCON OUT
4. powerCON IN
5. 3pin DMX IN
6. Safety Cable Attachment Point
7. Dual Yoke/Stand
8. 5pin DMX IN
9. DOWN Button
10. UP Button
11. MODE Button
12. LCD Menu Display
13. Microphone
14. 5pin DMX OUT

## FIXTURE INSTALLATION



### CAUTION!

Please consider the GB7000.15/EN60598-2-17 and the other respective national norms during the installation. The installation must only be carried out by a qualified person.



### CAUTION!

The electric connection must only be carried out by a qualified electrician.

## CAUTIONS

- For added protection, mount the fixture in areas outside walking paths, seating areas, or in areas where unauthorized personnel might reach the fixture.
- Max ambient operating temperature for this fixture is **113°F. (45°C)**  
Do not use the fixture under or above this temperature.
- Before mounting the fixture to any surface, make sure the installation area can hold a minimum point load of 10 times the weight of the fixture. **105 lbs / 48 kg)**
- Fixture installation must always be secured with a secondary safety attachment, such as an appropriate safety cable.
- Never stand directly below the device when mounting, removing or servicing.

## POWER LINKING

Max number of units that can be power linked is **10 units @120V.**

## CLAMP MOUNTING

The **OPTI QA PAR™** provides a unique integrated Dual Yoke / Floor Stand. When mounting this fixture to truss be sure to secure an appropriately rated clamp using an M10 screw fitted through the center hole of the Dual Yoke / Floor Stand.

## SECURING

Regardless of the rigging option you choose for your **OPTI QA PAR™** always be sure to secure your fixture with a safety cable. The fixture provides a built-in rigging point for a safety cable on the hanging bracket as illustrated above. Be sure to only use the designated rigging point for the safety cable and never secure a safety cable to a carrying handle.

## MOUNTING POINTS

- Overhead mounting requires extensive experience, including amongst others calculating working load limits, installation material being used, and periodic safety inspection of all installation material and the device. If you lack these qualifications, do not attempt the installation yourself. Improper installation can result in bodily injury.
- Fixture is fully operational in the specific mounting positions as illustrated below.

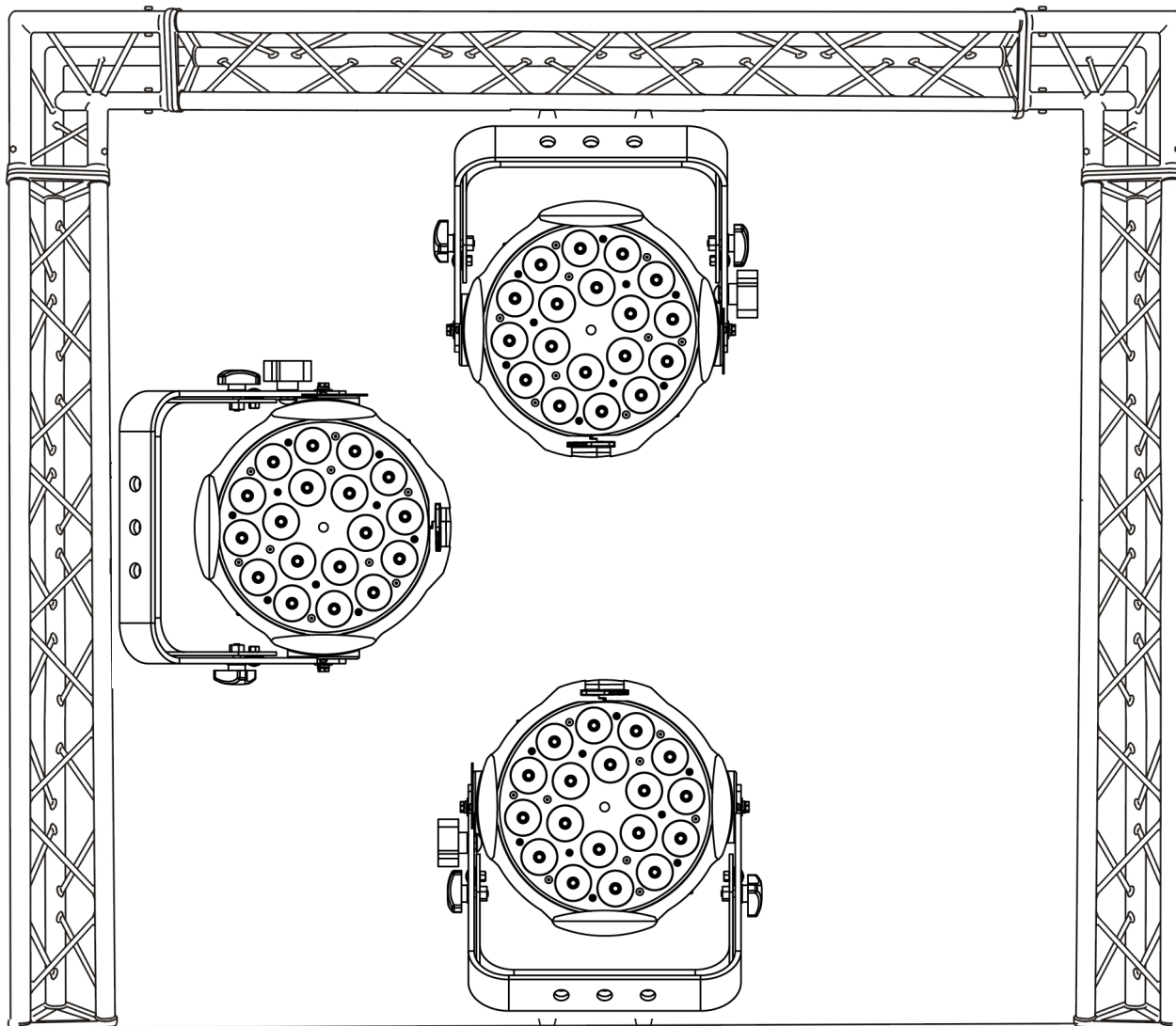

## SAFETY CABLE

**Always use a Safety Cable whenever installing this fixture in a suspended environment to ensure the fixture will not drop if the clamp fails.**

## UNDERSTANDING DMX

### DMX-512

DMX is short for Digital Multiplex. This is a universal protocol used by most lighting and controller manufactures as a form of communication between intelligent fixtures and controllers. DMX allows all makes and models of different manufactures to be linked together and operate from a single controller. This is possible as long as all the fixtures and the controller are DMX compliant. A DMX controller sends the DMX data instructions to the fixture allowing the user to control the different aspects of an intelligent light. DMX data is sent out as serial data that travels from fixture to fixture via data "IN" and data "OUT" XLR terminals located on the fixtures (most controllers will only have output jacks).

### DMX LINKING

To ensure proper DMX data transmission, always use proper DMX cables and a terminator. When using several DMX fixtures try to use the shortest cable path possible. Never split a DMX line with a "Y" style connector. The order in which the fixtures are connected in a DMX line does not influence the DMX addressing. For example; a fixture assigned a starting DMX address of 1 may be placed anywhere in the DMX chain, at the beginning, at the end, or anywhere in the middle. The DMX controller knows to send data assigned to address 1 to that fixture no matter where it is located in the DMX chain. The **OPTI QA PAR™** can be controlled via DMX-512 protocol and the DMX address is set via the control menu.

### DATA CABLE (DMX Cable) REQUIREMENTS (For DMX and Master/Slave Operation)

Your fixture and your DMX controller require a standard 3pin or 5pin XLR connector for data input and data output (see figure below). If you are making your own cables, be sure to use two conductor, shielded digital DMX cable rated at 120 ohms; this cable is designed for DMX transmission and may be purchased from your Elation dealer or at most professional lighting retailers. Your cables should be made with a male and female XLR connector on either end of the cable. Also, remember that a DMX line must be daisy chained and cannot be split, unless using an approved DMX splitter such as **Elation's Opto Branch 4™, Opto Branch 8™, or DMX-Branch/4™**.

DMX Output  
3-Pin XLR Socket



DMX Input  
3-Pin XLR Socket

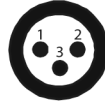

1: Ground  
2: Data (-)  
3: Data (+)

DMX Output  
5-Pin XLR Socket



DMX Input  
5-Pin XLR Socket

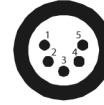

1: Ground  
2: Data (-)  
3: Data (+)  
4: Open  
5: Open



Be sure to follow the above figure when making your own cables. Do not use the ground lug on the XLR connector. Do not connect the cable's shield conductor to the ground lug or allow the shield conductor to come in contact with the XLR outer casing. Grounding the shield could cause a short circuit and erratic behavior.

### DMX-512 CONTROLLER CONNECTION

Connect the provided XLR cable to the female XLR output of your controller and the other side to the male XLR input of the **OPTI QA PAR™**. The diagram below illustrates a typical DMX-512 connection when the fixture is in the **9 Channel Mode**. You can chain multiple panels together through serial linking. The cable that should be used is two conductor, shielded DMX cable with XLR input and output connectors. Always be sure daisy chain your in and out data connections, never split or "Y" your DMX connections unless you are using an approved DMX splitter such as **Elation's Opto Branch 4™, Opto Branch 8™, or DMX-Branch/4™**.

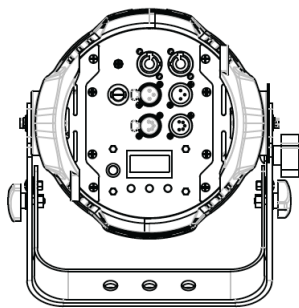

Address 1

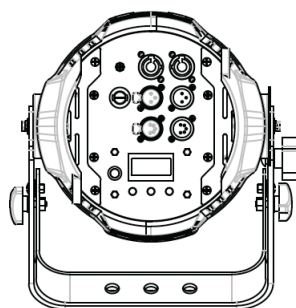

Address 10

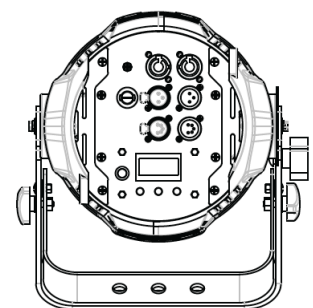

Address 19



## DMX-512 CONNECTION WITH DMX TERMINATOR

A DMX terminator should be used in all DMX lines especially in longer runs. The use of a terminator may avoid erratic behavior in your DMX line. A terminator is a 120 ohm 1/4 watt resistor that is connected between pins 2 and 3 of a male XLR connector (DATA + and DATA -). This fixture is inserted in the female XLR connector of the last fixture in your daisy chain to terminate the line. Using a line terminator will decrease the possibilities of erratic behavior.

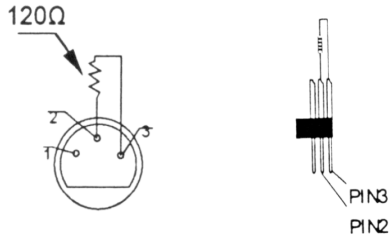

Termination reduces signal errors and avoids signal transmission problems and interference. It is always advisable to connect a DMX terminal, (Resistance 120 Ohm 1/4 W) between PIN 2 (DMX-) and PIN 3 (DMX +) of the last fixture.

## 5pin XLR DMX CONNECTORS

Some manufactures use 5pin XLR connectors for DATA transmission in place of 3pin. 5pin XLR fixtures may be implemented in a 3pin XLR DMX line. When inserting standard 5pin XLR connectors in to a 3pin line a cable adaptor must be used, these adaptors are readily available at most electric stores. The following chart details a proper cable conversion.

3-Pin XLR to 5-Pin XLR Conversion		
Conductor	3-Pin XLR Female (Out)	5-Pin XLR Male (In)
Ground/Shield	Pin 1	Pin 1
Data Compliment (- signal)	Pin 2	Pin 2
Data True (+ signal)	Pin 3	Pin 3
Not Used		Pin 4 - Do Not Use
Not Used		Pin 5 - Do Not Use

## DMX ADDRESSING

All fixtures should be given a DMX starting address when using a DMX controller, so the correct fixture responds to the correct control signal. This digital starting address is the channel number from which the fixture starts to “listen” to the digital control information sent out from the DMX controller. The allocation of this starting DMX address is achieved by setting the correct DMX address on the digital display located on the back of the fixture.

You can set the same starting address for all fixtures or a group of fixtures, or set different address for each individual fixture. Be advised that setting all fixtures to the same DMX address will subsequently control all fixtures in the same fashion, in other words, changing the settings of one channel will affect all the fixtures simultaneously.

If you set each fixture to a different DMX address, each unit will start to “listen” to the channel number you have set, based on the quantity of control channels (DMX channels) of each fixture. That means changing the settings of one channel will only affect the selected fixture.

In the case of the **OPTI QA PAR™**, when in the **9 Channel** you should set the starting DMX address of the first unit to 1, the second unit to 10 (1 + 9), the third unit to 19 (10 + 9), and so on.

**Note:** During start-up the **OPTI QA PAR™** will automatically detect whether a DMX data signal is being received or not. If DMX data signal is being received, the display will show "**Addr=XXX**" (**XXX** representing the actual DMX address). If the fixture is not receiving a DMX signal the display will flash. If your fixture is connected to a DMX controller and the display is flashing (not receiving a DMX signal), please check the following:

- The 3pin or 5pin XLR input plug (cable with DMX signal from controller) is not connected or is not inserted completely into the DMX input jack of the fixture.
- The DMX controller is switched off or defective.
- The DMX cable or connector is defective.
- A DMX terminator has been inserted into the last fixture in your DMX chain.

# FIXTURE MENU

## ON-BOARD SYSTEM MENU

The **OPTI QA PAR™** comes with an easy to navigate system menu. The next sections will cover how to access each menu function.

### LCD CONTROL PANEL DISPLAY

The (3) button control panel (see image below) located on back of the fixture allows you to access the main menu and make all necessary adjustments to the **OPTI QA PAR™**.

During normal operation, pressing the **MODE** button will navigate through the different function menus. Once you reach a desired menu, the variable field can be adjusted within the selected menu by using the **UP** or **DOWN** buttons, until the desired value is displayed. For example, the **RampMode** menu variable field can be set to **0, 1, 2, 3, or 4**. Press the **UP or DOWN** buttons to select the desired value and confirm your selection by pressing the **MODE** button. Exit at any time without making any adjustments by pressing the **MODE** button.

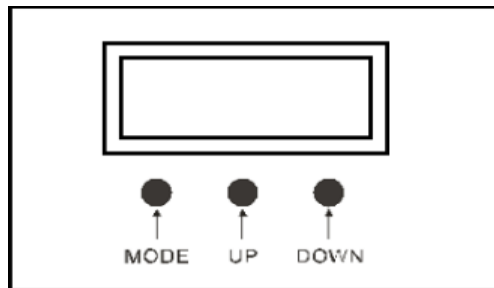

### INFORMATION DISPLAYED DURING INITIAL POWER ON

When the fixture is initially powered ON, the display shows the following information:

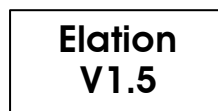

Fixture Software Version



**ELATION® OPTI QA PAR™  
SYSTEM MENU - VERSION 2**

Specifications are subject to change without any prior written notice.



MENU	OPTIONS / VALUES	DESCRIPTION
DispPerm	ON	LCD Display Backlight Always ON
	OFF	LCD Display Backlight OFF/LOCKED after 30 seconds. To UNLOCK Display, press any button for 10 seconds.
RampMode	Curve = (0) Standard, (1) Stage, (2) TV, (3) Architectural, (4) Theatre	Set Dimming Curve
DMX	1-CH, 3-CH, 5-CH, 6-CH, 8-CH, 9-CH	DMX Channel Mode
	001 ~ 512	DMX Address Setting
ColMacro	Macro = 0 ~ 64	Set Color Macro
ColMacro	Sound	Sound Active Mode to change Color Macros
ColProgr	Progr = All, 1 ~9	Set Internal Program
ColSpeed	Speed = 1 ~ 16, Sound	Set Internal Program Chase Speed
ColSet	Red = 0 ~ 255	Set Red LED value manually
ColSet	Blue = 0 ~ 255	Set Blue LED value manually
ColSet	Green = 0 ~ 255	Set Green LED value manually
ColSet	Amber = 0 ~ 255	Set Amber LED value manually

## DIMMING CURVES

The **RampMode** menu allows you to select one of the following preset dimming curves: **(0) Standard**, **(1) Stage**, **(2) TV**, **(3) Architectural**, or **(4) Theatre**.

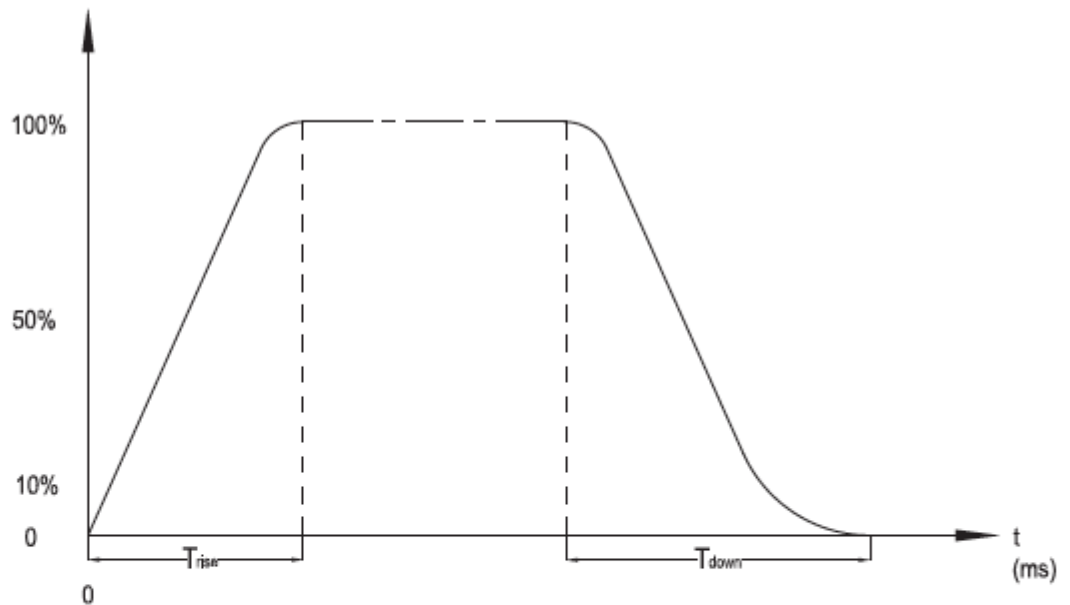
(See diagram below for more details)

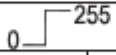

Ramp Effect	0  255 OS (Fade Time)		0  255 1S (Fade Time)	
	$T_{rise}$ (ms)	$T_{down}$ (ms)	$T_{rise}$ (ms)	$T_{down}$ (ms)
Standard	0	0	0	0
Stage	780	1100	1540	1660
TV	1180	1520	1860	1940
Architectural	1380	1730	2040	2120
Theatre	1580	1940	2230	2280

# DMX CHANNEL FUNCTIONS AND VALUES

ELATION® OPTI QA PAR™							
DMX Channel Values / Functions VERSION 2 (9 DMX Channels)							
Specifications are subject to change without any prior written notice.							
MODE / CHANNEL						VALUE	FUNCTION
1 CH	3 CH	5 CH	6 CH	8 CH	9CH		
		1	1	1	1		RED*
						0-255	*RED Control Disabled when fixture is in 8 or 9 CH Mode and CH 5 Color Macros are being used. RED (0-100%)
		2	2	2	2		GREEN*
						0-255	*GREEN Control Disabled when fixture is in 8 or 9 CH Mode and CH 5 Color Macros are being used. GREEN (0-100%)
		3	3	3	3		BLUE*
						0-256	*BLUE Control Disabled when fixture is in 8 or 9 CH Mode and CH 5 Color Macros are being used. BLUE (0-100%)
		4	4	4	4		AMBER*
						0-255	*AMBER Control Disabled when fixture is in 8 or 9 CH Mode and CH 5 Color Macros are being used. AMBER (0-100%)
							COLOR MACROS
						0	OFF
						1-4	COLOR MACRO 1
						5-8	COLOR MACRO 2
						9-12	COLOR MACRO 3
						13-16	COLOR MACRO 4
						17-20	COLOR MACRO 5
						21-24	COLOR MACRO 6
						25-28	COLOR MACRO 7
						29-32	COLOR MACRO 8
						33-36	COLOR MACRO 9
						37-40	COLOR MACRO 10
						41-44	COLOR MACRO 11
1	1			5	5	45-48	COLOR MACRO 12
						49-52	COLOR MACRO 13
						53-56	COLOR MACRO 14
						57-60	COLOR MACRO 15
						61-64	COLOR MACRO 16
						65-68	COLOR MACRO 17
						69-72	COLOR MACRO 18
						73-76	COLOR MACRO 19
						77-80	COLOR MACRO 20
						81-84	COLOR MACRO 21
						85-88	COLOR MACRO 22
						89-92	COLOR MACRO 23
						93-96	COLOR MACRO 24
						97-100	COLOR MACRO 25

ELATION® OPTI QA PAR™							
DMX Channel Values / Functions VERSION 2 (9 DMX Channels)							
Specifications are subject to change without any prior written notice.							
MODE / CHANNEL						VALUE	FUNCTION
1 CH	3 CH	5 CH	6 CH	8 CH	9CH		
						101-104	COLOR MACRO 26
						105-108	COLOR MACRO 27
						109-112	COLOR MACRO 28
						113-116	COLOR MACRO 29
						117-120	COLOR MACRO 30
						121-124	COLOR MACRO 31
						125-128	COLOR MACRO 32
						129-132	COLOR MACRO 33
						133-136	COLOR MACRO 34
						137-140	COLOR MACRO 35
						141-144	COLOR MACRO 36
						145-148	COLOR MACRO 37
						149-152	COLOR MACRO 38
						153-156	COLOR MACRO 39
						157-160	COLOR MACRO 40
						161-164	COLOR MACRO 41
						165-168	COLOR MACRO 42
						169-172	COLOR MACRO 43
						173-176	COLOR MACRO 44
						177-180	COLOR MACRO 45
						181-184	COLOR MACRO 46
						185-188	COLOR MACRO 47
						189-192	COLOR MACRO 48
						193-196	COLOR MACRO 49
						197-200	COLOR MACRO 50
						201-204	COLOR MACRO 51
						205-208	COLOR MACRO 52
						209-212	COLOR MACRO 53
						213-216	COLOR MACRO 54
						217-220	COLOR MACRO 55
						221-224	COLOR MACRO 56
						225-228	COLOR MACRO 57
						229-232	COLOR MACRO 58
						233-236	COLOR MACRO 59
						237-240	COLOR MACRO 60
						241-244	COLOR MACRO 61
						245-248	COLOR MACRO 62
						249-252	COLOR MACRO 63
						253-255	COLOR MACRO 64

ELATION® OPTI QA PAR™							
DMX Channel Values / Functions VERSION 2 (9 DMX Channels)							
Specifications are subject to change without any prior written notice.							
MODE / CHANNEL						VALUE	FUNCTION
1 CH	3 CH	5 CH	6 CH	8 CH	9CH		
				6	6		<b>STROBE / SPEED*</b>
							*SPEED Control ONLY available when fixture is in 9 CH Mode and CH 7 DMX Value is (128-223)
						0-15	NO STROBE / OFF
						16-255	STROBE Effect SLOW to FAST
						0-255	*SPEED Control SLOW to FAST
							<b>MODE</b>
					7	0-127	NO Function
						128-159	Automatic COLOR Mixing
						160-191	3 COLOR Change
						192-223	7 COLOR Change
						224-255	64 COLOR MACRO SOUND Active
	2		5	7	8		<b>DIMMER INTENSITY</b>
						0-255	Intensity 0 to 100%
							<b>DIMMING CURVE MODES</b>
					9	0-20	STANDARD
						21-40	STAGE
						41-60	TV
						61-80	ARCHITECTURAL
						81-100	THEATER
						101-255	Default to Unit Setting

## CLEANING AND MAINTENANCE



### CAUTION!

Disconnect from mains before starting maintenance operation.

### CLEANING

Frequent cleaning is recommended to insure proper function, optimized light output, and an extended life. The frequency of cleaning depends on the environment in which the fixture operates: damp, smoky or particularly dirty environments can cause greater accumulation of dirt on the fixture's optics.

- Clean the external lens surface at least every 20 days with a soft cloth to avoid dirt/debris accumulation. Never use alcohol, solvents, or ammonia based cleaners.

### MAINTENANCE

Regular inspections are recommended to insure proper function and extended life. There are no user serviceable parts inside this fixture, please refer all other service issues to an authorized Elation service technician. Should you need any spare parts, please order genuine parts from your local Elation dealer.

Please refer to the following points during routine inspections:

- A detailed electric check by an approved electrical engineer every 3 months, to make sure the circuit contacts are in good condition and prevent overheating.
- Be sure all screws and fasteners are securely tightened at all times. Loose screws may fall out during normal operation resulting in damage or injury.
- Check for any deformations on the housing, color lenses, rigging hardware and rigging points (ceiling, suspension, trussing). Deformations in the housing could allow for dust to enter into the fixture. Damaged rigging points or unsecured rigging could cause the fixture to fall and seriously injure a person(s).
- Inspect all moving parts and make sure there are no signs of wear and rotate/move without imbalances.
- Electric power supply cables must not show any damage, material fatigue or sediments. Never remove the ground prong from the power cable.

# TECHNICAL SPECIFICATIONS

## FEATURES

10° Beam Angle  
Smooth and Variable Curve Dimming Control  
Gel Frame Included  
Flicker Free Operation for TV and FILM

## SOURCE

18 x 5W QUAD Color (RGBA) LEDs  
50,000 Hour Average Life

## PHOTOMETRIC DATA

2065 LUX (192 FC) @9.8 ft. (3m) 10° Full ON

## EFFECTS

Multiple Color Macros  
Variable Color and Strobe Macros  
Variable Electronic Dimming Curves

## COLOR

RGBA (Red, Green, Blue, Amber)

## CONTROL / CONNECTIONS

6 DMX Channel Modes (1 / 3 / 5 / 6 / 8 / 9)  
3pin & 5pin DMX In/Out  
3 Button Control Panel  
LCD Menu Display  
powerCON Power In/Out  
Power Link Up To (10) Units at 120V

## SIZE / WEIGHT

Length: 10.9" (278mm)  
Width: 8.7" (221mm)  
Vertical Height: 14.1" (358mm)  
Weight: 10.6 lbs. (4.8kg)

## ELECTRICAL

AC 100-240V - 47/63Hz  
135W Max Power Consumption

## APPROVALS / RATINGS

CE Approved  
cETLus Approved  
IP20 Rated

## INSTALLATION

Rigging: Dual Yoke / Floor Stand  
Working Position: Any (360°)

**Please Note: Specifications and improvements in the design of this unit and this manual are subject to change without any prior written notice.**

## PHOTOMETRIC DATA

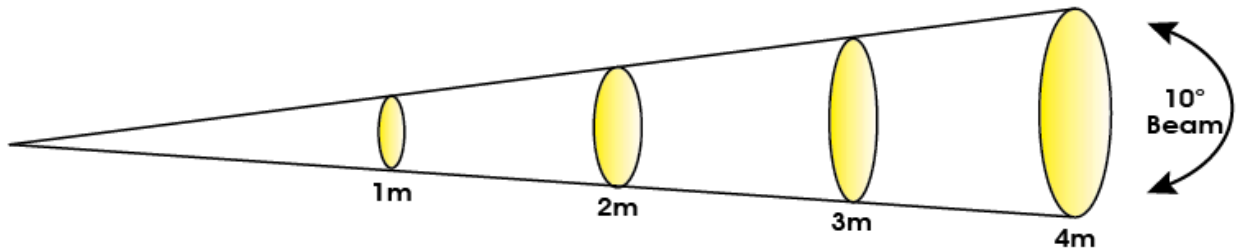

	m	ft	m	ft	m	ft	m	ft
Distance	1	3.3	2	6.6	3	9.8	4	13.1
Photometrics	lux	fc	lux	fc	lux	fc	lux	fc
RED LEDs	5,280	491	1,360	126	582	54	321	30
GREEN LEDs	7,590	705	2,113	196	920	85	515	48
BLUE LEDs	1,782	166	488	45	216	20	123	11
WHITE LEDs	6,640	617	1,763	164	753	70	420	39
ALL FULL ON	17,600	1,635	4,750	441	2,065	192	1,190	111

## DIMENSIONAL DRAWINGS

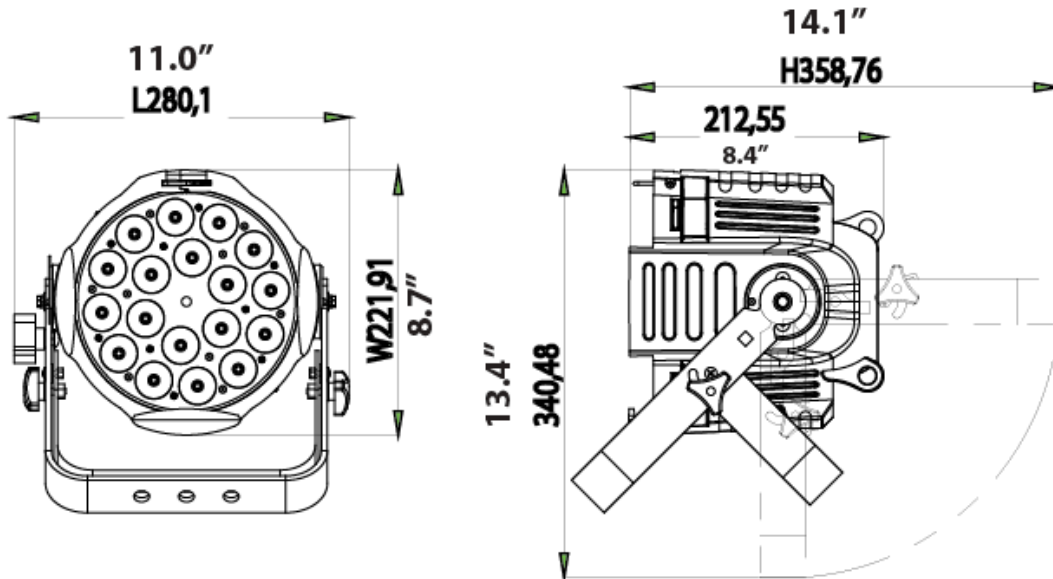

Please Note: Specifications and improvements in the design of this unit and this manual are subject to change without any prior written notice.



## OPTIONAL ACCESSORIES

ORDER CODE	ITEM
<b>TRIGGER CLAMP</b>	Heavy Duty Wrap Around Hook Style Clamp
<b>BD-03</b>	Barn Door
<b>LSF536</b>	Light Shaping Filter 30° 20" x 24" Sheet
<b>LSF537</b>	Light Shaping Filter 20° 20" x 22" Sheet
<b>LSF538</b>	Light Shaping Filter 60° x 1° 20" x 24" Sheet
<b>LSF559</b>	Light Shaping Filter 10° 20" x 24" Sheet
<b>EWDMXSYSTEM</b>	Wireless DMX System (1 Transmitter, 1 Receiver)
<b>EWDMXT</b>	Wireless DMX Transmitter
<b>EWDMXR</b>	Wireless DMX Receiver
<b>PLC3</b>	3' (1m) PowerCON PRO Link Cable
<b>PLC6</b>	6' (1.8m) PowerCON PRO Link Cable
<b>AC3PDMX5PRO</b>	5 ft. (1.5m) 3pin PRO DMX Cable
<b>AC5PDMX5PRO</b>	5 ft. (1.5m) 5pin PRO DMX Cable
	Additional Cable Lengths Available

