



EPAR TRI



User Instructions

EPAR TRI

Introduction

Unpacking: Thank you for purchasing the EPAR TRI by Elation Professional®. Every EPAR TRI has been thoroughly tested and has been shipped in perfect operating condition. Carefully check the shipping carton for damage that may have occurred during shipping. If the carton appears to be damaged, carefully inspect your fixture for any damage and be sure all accessories necessary to operate the unit has arrived intact. In the case damage has been found or parts are missing, please contact our customer support number for further instructions. Do not return this unit to your dealer without first contacting customer support.

Introduction: The EPAR TRI is part of Elation Professionals® continuing pursuit for creating high quality affordable intelligent fixtures. The EPAR TRI is a powerful DMX intelligent 3-in-1 RGB (Red, Green, & Blue) LED wash. This wash is light weight and compact which makes it a great piece for mobile DJ's and clubs. This unit can be used as a stand alone, or a sound-active mode. The unit can also be controlled via DMX controller.

Customer Support: ©Elation® provides a customer support line, to provide set up help and to answer any question should you encounter problems during your set up or initial operation. You may also visit us on the web at www.elationlighting.com for any comments or suggestions. Service Hours are Monday through Friday 8:00 a.m. to 4:30 p.m. Pacific Standard Time.

Voice: (323) 582-3322

Fax: (323) 832-9142

E-mail: support@elationlighting.com

Warning! To prevent or reduce the risk of electrical shock or fire, do not expose this unit to rain or moisture.

Caution! There are no user serviceable parts inside this unit. Do not attempt any repairs yourself, doing so will void your manufactures warranty. In the unlikely event your unit may require service please contact ©Elation customer support.

PLEASE recycle the shipping carton when ever possible.

EPAR TRI

General Instructions

To optimize the performance of this product, please read these operating instructions carefully to familiarize yourself with the basic operations of this unit. These instructions contain important safety information regarding the use and maintenance of this unit. Please keep this manual with the unit, for future reference.

EPAR TRI

Features

- Multi-Colors
- Built in Microphone
- Four Operating Modes
- Five Dimming Curves
- DMX-512 protocol
- Power Consumption Adjustment
- Six DMX Modes: 1 Channel Mode, 3 Channel Mode, 4 Channel Mode, 5 Channel Mode, 7 Channel Mode, & 8 Channel Mode
- Dimming 0-100% in 3 Channel Mode, 5 Channel Mode, 7 Channel Mode, & 8 Channel Mode.
- Daisy Chain Units Together in DMX Mode

EPAR TRI

Warranty Registration

The EPAR TRI carries a two year limited warranty. Please fill out the enclosed warranty card to validate your purchase. All returned service items whether under warranty or not, must be freight pre-paid and accompany a return authorization (R.A.) number. The R.A. number must be clearly written on the outside of the return package. A brief description of the problem as well as the R.A. number must also be written down on a piece of paper included in the shipping carton. If the unit is under warranty, you must provide a copy of your proof of purchase invoice. You may obtain a R.A. number by contacting our customer support team on our customer support number. All packages returned to the service department not displaying a R.A. number on the outside of the package will be returned to the shipper.

EPAR TRI

Safety Precautions

- To reduce the risk of electrical shock or fire, do not expose this unit rain or moisture
- Do not spill water or other liquids into or on to your unit.
- Do not attempt to operate this unit if the power cord has been frayed or broken. Do not attempt to remove or break off the ground prong from the electrical cord. This prong is used to reduce the risk of electrical shock and fire in case of an internal short.
- Disconnect from main power before making any type of connection.
- Do not remove the cover under any conditions. There are no user serviceable parts inside.
- Never operate this unit when it's cover is removed.
- Never plug this unit in to a dimmer pack
- Always be sure to mount this unit in an area that will allow proper ventilation. Allow about 6" (15cm) between this device and a wall.
- Do not attempt to operate this unit, if it becomes damaged.
- This unit is intended for indoor use only, use of this product out doors voids all warranties.
- During long periods of non-use, disconnect the unit's main power.
- Always mount this unit in safe and stable matter.
- Power-supply cords should be routed so that they are not likely to be walked on or pinched by items placed upon or against them, paying particular attention to the point they exit from the unit.
- Cleaning -The fixture should be cleaned only as recommended by the manufacturer. See page 17 for cleaning details.
- Heat -The appliance should be situated away from heat sources such as radiators, heat registers, stoves, or other appliances (including amplifiers) that produce heat.
- The fixture should be serviced by qualified service personnel when:
 - A. The power-supply cord or the plug has been damaged.
 - B. Objects have fallen, or liquid has been spilled into the appliance.
 - C. The appliance has been exposed to rain or water.
 - D. The appliance does not appear to operate normally or exhibits a marked change in performance.

Power Supply: The Elation EPAR TRI contains a automatic voltage switch, which will auto sense the voltage when it is plugged into the power source. With this switch there is no need to worry about the correct power voltage, this unit can be plugged in anywhere.

DMX-512: DMX is short for Digital Multiplex. This is a universal protocol used by most lighting and controller manufactures as a form of communication between intelligent fixtures and controllers. A DMX controller sends DMX data instructions from the controller to the fixture. DMX data is sent as serial data that travels from fixture to fixture via the DATA “IN” and DATA “OUT” XLR terminals located on all DMX fixtures (most controllers only have a DATA “OUT” terminal).

DMX Linking: DMX is a language allowing all makes and models of different manufactures to be linked together and operate from a single controller, as long as all fixtures and the controller are DMX compliant. To ensure proper DMX data transmission, when using several DMX fixtures try to use the shortest cable path possible. The order in which fixtures are connected in a DMX line does not influence the DMX addressing. For example; a fixture assigned a DMX address of 1 may be placed anywhere in a DMX line, at the beginning, at the end, or anywhere in the middle. When a fixture is assigned a DMX address of 1, the DMX controller knows to send DATA assigned to address 1 to that unit, no matter where it is located in the DMX chain.

Data Cable (DMX Cable) Requirements (For DMX Operation):

The EPAR TRI has 6 DMX Channel Modes. The DMX address is set electronically using the controls on the rear panel of the unit. Your unit and your DMX controller require a approved DMX-512 110 Ohm Data cable for data input and data output. We recommend Accu-Cable DMX cables. If you are making your own cables, be sure to use standard 110-120 Ohm shielded cable (This cable may be purchased at almost all professional sound and lighting stores). Your cables should be made with a male and female XLR connector on either end of the cable. Also remember that DMX cable must be daisy chained and cannot be split.



Figure 1

Special Note: Line Termination. When longer runs of cable are used, you may need to use a terminator on the last unit to avoid erratic behavior. A terminator is a 110-120 ohm 1/4 watt resistor which is connected between pins 2 and 3 of a male XLR connector (DATA + and DATA -). This unit is inserted in the female XLR connector of the last unit in your daisy chain to terminate the line. Using a cable terminator (ADJ part number Z-DMX/T) will decrease the possibilities of erratic behavior.



Termination reduces signal errors and avoids signal transmission problems and interference. It is always advisable to connect a DMX terminal, (Resistance 120 Ohm 1/4 W) between PIN 2 (DMX-) and PIN 3 (DMX +) of the last fixture.

5-Pin XLR DMX Connectors. Some manufactures use 5-pin DMX-512 data cables for DATA transmission in place of 3-pin. 5-pin DMX fixtures may be implemented in a 3-pin DMX line. When inserting standard 5-pin data cables in to a 3-pin line a cable adaptor must be used, these adaptors are readily available at most electric stores. The chart below details a proper cable conversion.

3-Pin XLR to 5-Pin XLR Conversion		
Conductor	3-Pin XLR Female (Out)	5-Pin XLR Male (In)
Ground/Shield	Pin 1	Pin 1
Data Compliment (- signal)	Pin 2	Pin 2
Data True (+ signal)	Pin 3	Pin 3
Not Used		Do Not Use
Not Used		Do Not Use

LED Display On/Off:

To set the LED display to turn off after 10 seconds, press the MODE button until ds-X is displayed, “X” representing either 1 or 2. Press the UP or DOWN button so that ds-2 is displayed, now the display will turn off after 10secs. Press any button for at least 5secs. to turn the display on again. Be advised though that the display will turn off automatically after 10 seconds of inactivity.

ds-1= LCD display on at all times.

ds-2= LCD display shuts off after 10 seconds.

Operating Modes:

You can use the EPAR TRI in four ways:

- Macro Mode - There are 32 color macros to choose from.
- Auto Mode - There are 6 built in programs to choose from.
- RGB mode - Control the intensity of all three colors adjusting the intensity to your desire.
- DMX control mode - This function will allow you to control each individual fixtures traits with a standard DMX 512 controller such as the Elation® Show Designer™.

Macro Mode:

1. Plug the fixture in and press the MODE button until “8-XX” is displayed. “XX” representing a number between 0-32.
2. There are 32 macros to choose from. Select your desired macro by pressing the UP and DOWN buttons.

Program Mode:

1. Plug the fixture in and press the MODE button until “9-XX” is displayed. “XX” representing a number between 1-06 or AL.
2. There are 6 built-in programs to choose from. Select your desired program by pressing the UP and DOWN buttons. You can set your program speed by following the next set of instructions.

Program Mode Speed Adjustment:

1. To adjust the speed of your program press the MODE button until “A-XX” is displayed.
2. Press the UP or DOWN buttons to make the adjustmetns. “A-01” is the slowest speed, “A-16” the fastest speed. When the display reads “A-So” the Auto mode is running by sound activity.

RGB Mode:

1. Plug the fixture in and press the MODE button until:
2. When rXXX is displayed you are in Red dimming mode. Press the UP and DOWN buttons to adjust intensity.
3. When GXXX is displayed you are in Green dimming mode. Press the UP and DOWN buttons to adjust intensity.
4. When bXXX is displayed you are in Blue dimming mode. Press the UP and DOWN buttons to adjust intensity.

DMX Mode:

Operating through a DMX controller gives the user the freedom to create their own programs tailored to their own individual needs. The EPAR TRI has 6 DMX modes: 1 Channel mode, 3 Channel mode, 4 Channel mode, 5 Channel mode, 7 Channel mode, and a 8 Channel mode. See pages 10-14 for each modes’ DMX traits.

1. This function will allow you to control each individual fixture’s traits with a standard DMX 512 controller such as the Elation® Show Designer™ or the Elation® DMX Operator™.
2. To run your fixture in DMX mode, plug in the fixture via the XLR connections to any standard DMX controller. Select your desired DMX mode, and then press the UP or DOWN buttons to adjust the DMX address. **XXX = DMX Address**
3. To run the 1 Channel Mode, press the MODE button until “1XXX” is displayed. This is the DMX addressing for the 1 Channel Mode.
4. To run the 3 Channel Mode, press the MODE button until “2XXX” is displayed. This is the DMX addressing for the 3 Channel Mode.
5. To run the 4 Channel Mode, press the MODE button until “3XXX” is displayed. This is the DMX addressing for the 4 Channel Mode.
6. To run the 5 Channel Mode, press the MODE button until “4XXX” is displayed. This is the DMX addressing for the 5 Channel Mode.
7. To run the 7 Channel Mode, press the MODE button until “5XXX” is displayed. This is the DMX addressing for the 7 Channel Mode.
8. To run the 8 Channel Mode, press the MODE button until “6XXX” is displayed. This is the DMX addressing for the 8 Channel Mode.
9. Please see pages 10-14 for DMX values and traits.

Dimmer Curve Setting:

1. Plug the fixture in and press the MODE button until “dr-X” is displayed. “X” representing a number between 0-4.

EPAR TRI**Operating Instructions**

- There are 5 dimmer curve settings to choose from. Please see the Dimmer Curve Diagram Chart on page 16 to see the settings and their respective beginning and ending fade times.

Power Consumption Adjustment:

- Plug the fixture in and press the MODE button until “PXXX” is displayed. “XXX” representing a number between 001-003.
- “001” is the lowest power consumption, and “003” is highest power consumption. To change the power consumption press the UP or DOWN buttons for at least 15 seconds. See page 17 for a power consumption setting chart.

NOTE: The power consumption setting will have a tiny effect on the output intensity.

EPAR TRI**Master-Slave Configuration****Master-Slave Operation:**

This function will allow you to link units together to run in a Master-Slave mode. In Master-Slave operation one unit will act as the controlling unit and the others will react to the controlling units built-in programs. Any unit can act as a Master or as a Slave however, only one unit can be programmed to act as the “Master.”

Master-Slave Connections and Settings:

- Daisy chain your units via the XLR connector on the rear of the unit. Use standard XLR data cables to link your units together. Remember that the Male XLR connector is the input and the Female XLR connector is the output. The first unit in the chain (master) will use the female XLR connector only. The last unit in the chain will use the male XLR connector only.
- Set the “Master” unit to your desired mode or operation.
- For the “Slave” unit(s), set the display to any DMX channel mode. Example: Set the unit to 4 channel mode, the display should read “3000” or any variables, i.e “3001”, “3002 etc..
- Connect the “Slave” unit or units and they will automatically start to follow the “Master.”

EPAR TRI 1 Channel Mode - DMX Values and Functions

Channel	Value	Function
1	0	<u>COLOR MACROS</u>
		OFF
	1 - 7	BASTARD AMBER
	8 - 15	MEDIUM AMBER
	16 - 23	PALE AMBER GOLD
	24 - 31	GALLO GOLD
	32 - 39	GOLDEN AMBER
	40 - 47	LIGHT RED
	48 - 55	MEDIUM RED
	56 - 63	MEDIUM PINK
	64 - 71	BROADWAY PINK
	72 - 79	FOLLIES PINK
	80 - 87	LIGHT LAVENDER
	88 - 95	SPECIAL LAVENDER
	96 - 103	LAVENDER
	104 - 111	INDIGO
	112 - 119	HEMSLEY BLUE
	120 - 127	TIPTON BLUE
	128 - 135	LIGHT STEEL BLUE
	136 - 143	LIGHT SKY BLUE
	144 - 151	SKY BLUE
	152 - 159	BRILLIANT BLUE
	160 - 167	LIGHT GREEN BLUE
	168 - 175	BRIGHT BLUE
	176 - 183	PRIMARY BLUE
	184 - 191	CONGO BLUE
	192 - 199	PALE YELLOW GREEN
200 - 207	MOSS GREEN	
208 - 215	PRIMARY GREEN	
216 - 223	DOUBLE CTB	
224 - 231	FULL CTB	
232 - 239	HALF CTB	
240 - 247	DARK BLUE	
248 - 255	WHITE	

EPAR TRI 3 Channel Mode - DMX Values and Functions

Channel	Value	Function
1	1 - 255	COLOR MACROS PLEASE SEE 1 CHANNEL MODE
2	0 - 255	MASTER DIMMER 0% - 100%
3	0 - 20 21 - 40 41 - 60 61 - 80 81 - 100 101 - 255	DIMMER CURVE SETTING DR-0 SETTING DR-1 SETTING DR-2 SETTING DR-3 SETTING DR-4 SETTING DIMMER CURVE SETTING IS ACTIVE

Channel 3 is the dimmer curve setting, please see the Dimmer Curve Diagram Chart on page 16 to see the settings and their respective beginning and ending fade times.

EPAR TRI 4 Channel Mode - DMX Values and Functions

Channel	Value	Function
1	0 - 255	RED 0% - 100%
2	0 - 255	GREEN 0% - 100%
3	0 - 255	BLUE 0% - 100%
4	0 - 20 21 - 40 41 - 60 61 - 80 81 - 100 101 - 255	DIMMER CURVE SETTING DR-0 SETTING DR-1 SETTING DR-2 SETTING DR-3 SETTING DR-4 SETTING DIMMER CURVE SETTING IS ACTIVE

Channel 4 is the dimmer curve setting, please see the Dimmer Curve Diagram Chart on page 16 to see the settings and their respective beginning and ending fade times.

EPAR TRI 5 Channel Mode - DMX Values and Functions

Channel	Value	Function
1	0 - 255	RED 0% - 100%
2	0 - 255	GREEN 0% - 100%
3	0 - 255	BLUE 0% - 100%
4	0 - 255	MASTER DIMMER 0% - 100%
5	0 - 20 21 - 40 41 - 60 61 - 80 81 - 100 101 - 255	DIMMER CURVE SETTING DR-0 SETTING DR-1 SETTING DR-2 SETTING DR-3 SETTING DR-4 SETTING DIMMER CURVE SETTING IS ACTIVE

Channel 5 is the dimmer curve setting, please see the Dimmer Curve Diagram Chart on page 16 to see the settings and their respective beginning and ending fade times.

EPAR TRI 7 Channel Mode - DMX Values and Functions

Channel	Value	Function
1	0 - 255	RED 0% - 100%
2	0 - 255	GREEN 0% - 100%
3	0 - 255	BLUE 0% - 100%
4	1 - 255	COLOR MACROS PLEASE SEE 1 CHANNEL MODE
5	0 - 15 16 - 255	NOTHING STROBING/SPEED CONTROL
6	0 - 255	MASTER DIMMER 0% - 100%
7	0 - 20 21 - 40 41 - 60 61 - 80 81 - 100 101 - 255	DIMMER CURVE SETTING DR-0 SETTING DR-1 SETTING DR-2 SETTING DR-3 SETTING DR-4 SETTING DIMMER CURVE SETTING IS ACTIVE

Channel 1, 2, & 3 will not work, when Channel 4 is being used.

Channel 7 is the dimmer curve setting, please see the Dimmer Curve Diagram Chart on page 16 to see the settings and their respective beginning and ending fade times.

EPAR TRI 8 Channel Mode - DMX Values and Functions

Channel	Value	Function
1	0 - 255	RED 0% - 100%
2	0 - 255	GREEN 0% - 100%
3	0 - 255	BLUE 0% - 100%
4	1 - 255	COLOR MACROS PLEASE SEE 1 CHANNEL MODE
5	0 - 15 16 - 255 1 - 255	STROBING/PROGRAM SPEED NOTHING STROBING SLOW - FAST PROGRAM SPEED SLOW - FAST
6	0 - 127 128 - 159 160 - 191 192 - 223 224 - 255	MODE OFF AUTO MIX 3 COLOR JUMP 7 COLOR JUMP RANDOM MODE
7	0 - 255	MASTER DIMMER 0% - 100%
8	0 - 20 21 - 40 41 - 60 61 - 80 81 - 100 101 - 255	DIMMER CURVE SETTING DR-0 SETTING DR-1 SETTING DR-2 SETTING DR-3 SETTING DR-4 SETTING DIMMER CURVE SETTING IS ACTIVE

Channel 1, 2, & 3 will not work, when Channel 4 is being used.

When using Channel 6, Channel 5 will control the speed of the color changing.

Channel 8 is the dimmer curve setting, please see the Dimmer Curve Diagram Chart on page 16 to see the settings and their respective beginning and ending fade times.

EPAR TRI

Color Macro Chart

COLOR	RED	GREEN	BLUE
BASTARD AMBER	255	206	143
MEDIUM AMBER	254	177	153
PALE AMBER GOLD	254	192	138
GALLO GOLD	254	165	98
GOLDEN AMBER	254	121	0
LIGHT RED	176	17	0
MEDIUM RED	96	0	11
MEDIUM PINK	234	139	171
BROADWAY PINK	224	5	97
FOLLIES PINK	175	77	173
LIGHT LAVENDER	119	130	199
SPECIAL LAVENDER	147	164	212
LAVENDER	88	2	163
INDIGO	0	38	86
HEMSLEY BLUE	0	142	208
TIPTON BLUE	52	148	209
LIGHT STEEL BLUE	1	134	201
LIGHT SKY BLUE	0	145	212
SKY BLUE	0	121	192
BRILLIANT BLUE	0	129	184
LIGHT GREEN BLUE	0	83	115
BRIGHT BLUE	0	97	166
PRIMARY BLUE	1	100	167
CONGO BLUE	0	40	86
PALE YELLOW GREEN	209	219	182
MOSS GREEN	42	165	85
PRIMARY GREEN	0	46	35
DOUBLE CTB	8	107	222
FULL CTB	107	156	231
HALF CTB	165	198	247
DARK BLUE	0	0	189
WHITE	255	255	255

EPAR TRI

Dimmer Curve Diagram

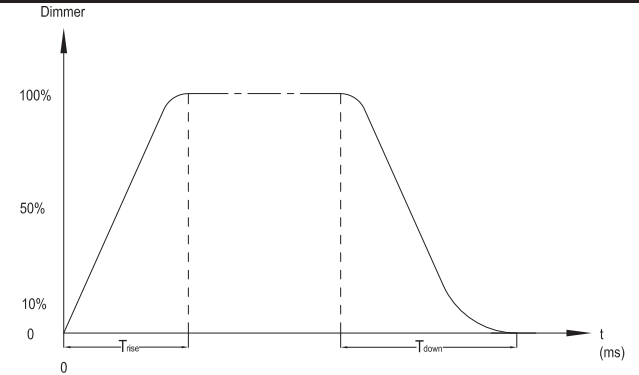

Ramp Effect	Unit Dim Mode	OS (Fade Time)		1S (Fade Time)	
		T _{rise} (ms)	T _{down} (ms)	T _{rise} (ms)	T _{down} (ms)
Standard	dr-0	0	0	0	0
Stage	dr-1	780	1100	1540	1660
TV	dr-2	1180	1520	1860	1940
Architectural	dr-3	1380	1730	2040	2120
Theatre	dr-4	1580	1940	2230	2280

EPAR TRI

Photometric Chart

EPAR TRI Photometric Beam Angle Data

Standard 10° Beam Angle

LUX x 0.0929 = FC

R	319 FC / 3433 LUX	78 FC / 842 LUX	36 FC / 392 LUX
G	1196 FC / 12870 LUX	311 FC / 3347 LUX	141 FC / 1515 LUX
B	134 FC / 1440 LUX	40 FC / 420 LUX	19 FC / 200 LUX
ALL	1512 FC / 16280 LUX	393 FC / 4230 LUX	180 FC / 1933 LUX

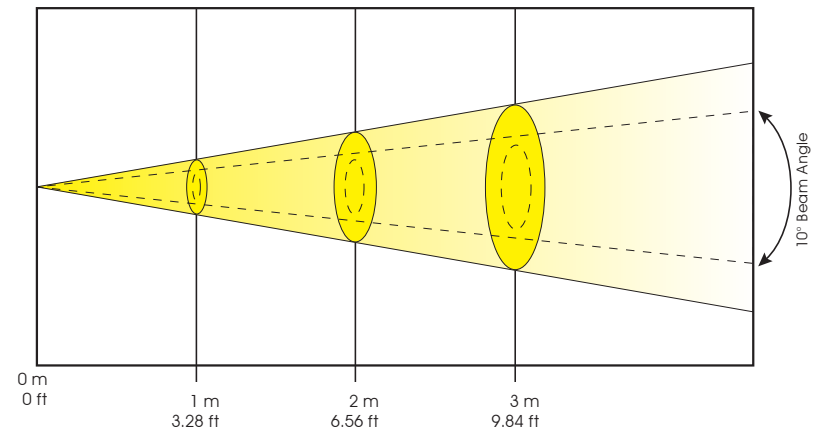

EPAR TRI**Power Consumption Setting**

	Display	120V/60Hz	230V/50Hz
EPAR TRI	P001	46W	46W
	P002	51W	51W
	P003	60W	60W

EPAR TRI**Cleaning**

Due to fog residue, smoke, and dust cleaning the internal and external optical lenses must be carried out periodically to optimize light output.

1. Use normal glass cleaner and a soft cloth to wipe down the outside casing.
2. Clean the external optics with glass cleaner and a soft cloth every 20 days.
3. Always be sure to dry all parts completely before plugging the unit back in.

Cleaning frequency depends on the environment in which the fixture operates (i.e. smoke, fog residue, dust, dew).

EPAR TRI**Trouble Shooting**

Listed below are a few common problems the user may encounter, with solutions.

Unit not responding to DMX:

1. Check that the DMX cables are connected properly and are wired correctly (pin 3 is “hot”; on some other DMX devices pin 2 may be ‘hot’). Also, check that all cables are connected to the right connectors; it does matter which way the inputs and outputs are connected.

EPAR TRI**Warranty****2-YEAR LIMITED WARRANTY**

A. Elation Professionals® hereby warrants, to the original purchaser, Elation Professionals® products to be free of manufacturing defects in material and workmanship for a period of two years (730 days) from the date of purchase. This warranty shall be valid only if the product is purchased within the United States of America, including possessions and territories. It is the owner’s responsibility to establish the date and place of purchase by acceptable evidence, at the time service is sought.

B. For warranty service, send the product only to the Elation Professionals® factory. All shipping charges must be pre-paid. If the requested repairs or service (including parts replacement) are within the terms of this warranty, Elation Professionals® will pay return shipping charges only to a designated point within the United States. If the entire instrument is sent, it must be shipped in its original package. No accessories should be shipped with the product. If any accessories are shipped with the product, Elation Professionals® shall have no liability whatsoever for loss of or damage to any such accessories, nor for the safe return thereof.

C. This warranty is void if the serial number has been altered or removed; if the product is modified in any manner which Elation Professionals® concludes, after inspection, affects the reliability of the product; if the product has been repaired or serviced by anyone other than the Elation Professionals® factory unless prior written authorization was issued to purchaser by Elation Professionals®; if the product is damaged because not properly maintained as set forth in the instruction manual.

D. This is not a service contract, and this warranty does not include maintenance, cleaning or periodic check-up. During the period specified above, Elation Professionals® will replace defective parts at its expense, and will absorb all expenses for warranty service and repair labor by reason of defects in material or workmanship. The sole responsibility of Elation Professionals® under this warranty shall be limited to the repair of the product, or replacement thereof, including parts, at the sole discretion of Elation Professionals®. All products covered by this warranty were manufactured after January 1, 1990, and bear identifying marks to that effect.

E. Elation Professionals® reserves the right to make changes in design and/or improvements upon its products without any obligation to include these changes in any products theretofore manufactured.

F. No warranty, whether expressed or implied, is given or made with respect to any accessory supplied with products described above. Except to the extent prohibited by applicable law, all implied warranties made by Elation Professionals® in connection with this product, including warranties of merchantability or fitness, are limited in duration to the warranty period set forth above. And no warranties, whether expressed or implied, including warranties of merchantability or fitness, shall apply to this product after said period has expired. The consumer’s and or Dealer’s sole remedy shall be such repair or replacement as is expressly provided above; and under no circumstances shall Elation Professionals® be liable for any loss or damage, direct or consequential, arising out of the use of, or inability to use, this product.

G. This warranty is the only written warranty applicable to Elation Professionals® Products and supersedes all prior warranties and written descriptions of warranty terms and conditions heretofore published.

Model: EPAR TRISPECIFICATIONS:

Working Position:	Any safe working position
Voltage:	100V ~ 240V/47~63Hz
LED's:	14 x 1 Watt Tri LED's (14 Red, 14 Blue, & 14 Green)
Power Consumption:	60.1W
Fuse:	2.5 Amp
Beam Angle:	10 Degrees
Weight:	9lbs./ 4.1Kgs.
Dimensions:	9.9" (L) x 8.5" (W) x 11" (H)
Colors:	RGB Color Mixing
DMX Channels:	6 DMX Modes: 1 Channel Mode, 3 Channel Mode, 4 Channel Mode, 5 Channel Mode, 7 Channel Mode, & 8 Channel Mode
Warranty:	2 Year (730 days)

Auto Sensing Voltage: *This fixture contains a automatic voltage switch, which will auto sense the voltage when it is plugged into the power source.*

Please Note: Specifications and improvements in the design of this unit and this manual are subject to change without any prior written notice.

©Elation Professionals®
A Division of the AmericanDJ® Group of Companies
World Headquarters:
6122 S. Eastern Ave. Los Angeles, CA 90040 USA
Tel: 323-582-3322 Fax: 323-832-9142
Web: www.elationlighting.com E-mail: info@elationlighting.com

American DJ Europe
Junostraat 2
6468 EW Kerkrade
Netherlands

service@adjgroup.eu / www.americandj.eu
Tel: +31 45 546 85 00 / Fax: +31 45 546 85 99