

E SPOT LED II™

user manual 1.0

©2013 **ELATION PROFESSIONAL** all rights reserved. Information, specifications, diagrams, images, and instructions herein are subject to change without notice. ELATION PROFESSIONAL logo and identifying product names and numbers herein are trademarks of ELATION PROFESSIONAL. Copyright protection claimed includes all forms and matters of copyrightable materials and information now allowed by statutory or judicial law or hereinafter granted. Product names used in this document may be trademarks or registered trademarks of their respective companies and are hereby acknowledged. All non-ELATION brands and product names are trademarks or registered trademarks of their respective companies.

ELATION PROFESSIONAL and all affiliated companies hereby disclaim any and all liabilities for property, equipment, building, and electrical damages, injuries to any persons, and direct or indirect economic loss associated with the use or reliance of any information contained within this document, and/or as a result of the improper, unsafe, insufficient and negligent assembly, installation, rigging, and operation of this product.

Elation Professional USA | 6122 S. Eastern Ave. | Los Angeles, CA. 90040
323-582-3322 | 323-832-9142 fax | www.elationlighting.com | info@elationlighting.com

Elation Professional B.V. | Junostraat 2 | 6468 EW Kerkrade, Netherlands
+31 45 546 85 66 | +31 45 546 85 96 fax | www.elationlighting.eu | info@elationlighting.eu

CONTENTS

General Information	4
Warranty	6
Safety Instructions	7
General Guidelines	8
Fixture Overview	9
Installation	10
Understanding DMX	13
Fixture Menu	17
DMX Channel Functions And Values	39
Error Codes	42
Cleaning and Maintenance	44
Technical Specifications	45
Optional Accessories	49
Declaration Of Conformity	50

GENERAL INFORMATION

INTRODUCTION

Congratulations, you have just purchased one of the most innovative and reliable lighting fixtures on the market today! The **E SPOT LED II™** has been designed to perform reliably for years when the guidelines in this booklet are followed. Please read and understand the instructions in this manual carefully and thoroughly before attempting to operate this unit. These instructions contain important information regarding safety during use and maintenance.

UNPACKING

Thank you for purchasing the **E SPOT LED II™** by Elation Professional®. Every **E SPOT LED II™** has been thoroughly tested and has been shipped in perfect operating condition. Carefully check the shipping carton for damage that may have occurred during shipping. If the carton appears to be damaged, carefully inspect your unit for damage and be sure all accessories necessary to operate the unit have arrived intact. In the event damage has been found or parts are missing, please contact our customer support team for further instructions. Please do not return this unit to your dealer without first contacting customer support at the number listed below. Please do not discard the shipping carton in the trash. Please recycle whenever possible.

BOX CONTENTS

- (1) Omega Bracket
- (1) 3pin DMX Cable
- (1) Safety Cable
- Manual & Warranty Card



MANUAL UPDATES

Please check www.elationlighting.com for the latest revision/update of this manual.

CUSTOMER SUPPORT

Elation Professional® provides a customer support line, to provide set up help and to answer any question should you encounter problems during your set up or initial operation. You may also visit us on the web at www.elationlighting.com for any comments or suggestions. For service related issue please contact Elation Professional®. Service Hours are Monday through Friday 8:00 a.m. to 5:00 p.m. PST.

Voice: 323-582-3322

Fax: 323-832-9142

E-mail: support@elationlighting.com

Forum: www.ElationLighting.com/forum

WARRANTY REGISTRATION

The **E SPOT LED II™** carries a two-year (730 days) limited warranty. Please fill out the enclosed warranty card to validate your purchase. All returned service items whether under warranty or not, must be freight pre-paid and accompany a return authorization (R.A.) number. The R.A. number must be clearly written on the outside of the return package. A brief description of the problem as well as the R.A. number must also be written down on a piece of paper and included in the shipping container. If the unit is under warranty, you must provide a copy of your proof of purchase invoice. Items returned without a R.A. number clearly marked on the outside of the package will be refused and returned at customer's expense. You may obtain a R.A. number by contacting customer support at 323-582-3322.



IMPORTANT NOTICE!

There are no user serviceable parts inside this unit. Do not attempt any repairs yourself; doing so will void your manufactures warranty. Damages resulting from modifications to this fixture and/or the disregard of safety and general user instructions found in this user manual void the manufactures warranty and are not subject to any warranty claims and/or repairs.

2-YEAR LIMITED WARRANTY

A. Elation Professional® hereby warrants, to the original purchaser, Elation Professional® products to be free of manufacturing defects in material and workmanship for a period of two years, (730 days) from the date of purchase. This warranty shall be valid only if the product is purchased within the United States of America, including possessions and territories. It is the owner's responsibility to establish the date and place of purchase by acceptable evidence, at the time service is sought.

B. For warranty service, send the product only to the Elation Professional® factory. All shipping charges must be pre-paid. If the requested repairs or service (including parts replacement) are within the terms of this warranty, Elation Professional® will pay return shipping charges only to a designated point within the United States. If the entire instrument is sent, it must be shipped in its original package. No accessories should be shipped with the product. If any accessories are shipped with the product, Elation Professional® shall have no liability what so ever for loss of or damage to any such accessories, nor for the safe return thereof.

C. This warranty is void if the serial number has been altered or removed; if the product is modified in any manner which Elation Professional® concludes, after inspection, affects the reliability of the product; if the product has been repaired or serviced by anyone other than the Elation Professional® factory unless prior written authorization was issued to purchaser by Elation Professional®; if the product is damaged because not properly maintained as set forth in the instruction manual.

D. This is not a service contract, and this warranty does not include maintenance, cleaning or periodic check-up. During the period specified above, Elation Professional® will replace defective parts at its expense, and will absorb all expenses for warranty service and repair labor by reason of defects in material or workmanship. The sole responsibility of Elation Professional® under this warranty shall be limited to the repair of the product, or replacement thereof, including parts, at the sole discretion of Elation Professional®. All products covered by this warranty were manufactured after January 1, 1990, and bare identifying marks to that effect.

E. Elation Professional® reserves the right to make changes in design and/or improvements upon its products without any obligation to include these changes in any products theretofore manufactured.

F. No warranty, whether expressed or implied, is given or made with respect to any accessory supplied with products described above. Except to the extent prohibited by applicable law, all implied warranties made by Elation Professional® in connection with this product, including warranties of merchantability or fitness, are limited in duration to the warranty period set forth above. And no warranties, whether expressed or implied, including warranties of merchantability or fitness, shall apply to this product after said period has expired. The consumer's and or Dealer's sole remedy shall be such repair or replacement as is expressly provided above; and under no circumstances shall Elation Professional® be liable for any loss or damage, direct or consequential, arising out of the use of, or inability to use, this product.

G. This warranty is the only written warranty applicable to Elation Professional® Products and supersedes all prior warranties and written descriptions of warranty terms and conditions heretofore published.

SAFETY INSTRUCTIONS



The **E SPOT LED II™** is an extremely sophisticated piece of electronic equipment. To guarantee a smooth operation, it is important to follow the guidelines in this manual. The manufacturer of this device will not accept responsibility for damages resulting from the misuse of this fixture due to the disregard of the information printed in this manual.



This device falls under **PROTECTION CLASS 1**. It's essential this device is grounded properly, and only qualified personnel perform all electrical connections.



CAUTION!

Never touch the device during operation!
The housing may heat up



CAUTION!

Never look directly into the light source,
as sensitive persons may suffer an epileptic shock.



CAUTION!

Keep this device away from rain and moisture !



CAUTION!

Unplug mains lead before opening the housing.

- For proper operation, follow the **Installation** guidelines described on page **10** of this manual. Only qualified and certified personnel should perform installation of this fixture and only the original rigging parts (brackets) included with this fixture should be used for installation. Any modifications will void the original manufacturer's warranty and increase the risk of damage and/or personal injury.
- Never look directly into the light source of this fixture to prevent risk of injury to your retina, which may induce blindness. Those suffering from **EPILEPSY** should avoid looking directly into the light source of this unit at all times.
- The fan and air inlets must remain clean and never blocked. Allow approx. 6" (15cm) between this fixture and other devices or a wall for proper cooling.
- Always disconnect from main power source before performing any type of service and/or cleaning procedure. Only handle the power cord by the plug end, never pull out the plug by tugging the wire portion of the cord.
- Do not operate this fixture if the power cord has become frayed, crimped and/or damaged. If the power cord is damaged, replace it immediately with a new one of similar power rating.

GENERAL GUIDELINES

- **NEVER OPEN THIS FIXTURE WHILE IN USE!**
- During the initial operation of this fixture, a light smoke or smell may emit from the interior of the fixture. This is a normal process and is caused by excess paint in the interior of the casing burning off from the heat associated with the lamp and will decrease gradually over time.
- This fixture is a professional lighting effect designed for **INDOOR / DRY LOCATIONS ONLY** on stage, in nightclubs, theatres, etc.
- Please make sure there are **NO FLAMMABLE MATERIALS** close to the fixture while operating, to prevent any fire hazard.
- The fixture must be installed in a location with adequate ventilation, at least 1.5 feet (.5m) from adjacent surfaces. Be sure no air ventilation slots are blocked.
- Do not attempt installation and/or operation without proper knowledge how to do so.
- Do not permit operation by persons who are not qualified for operating this type of theatrical fixture. Most damages are the result of operations by nonprofessionals.
- Consistent operational breaks may ensure the fixture will function properly for many years to come.
- Do not shake fixture, avoid brute force when installing and/or operating the device.
- Always install the fixture with an appropriate safety cable. When installing the fixture in a suspended environment, always use mounting hardware that is no less than M10 x 25 mm, also be sure the hardware is insert in the pre-arranged screw holes in the bracket of the fixture.
- Please use the original packaging and materials to transport the fixture in for service.
- **DO NOT TOUCH** the housing bare-hand during its operation. Turn OFF the power and allow approximately 15 minutes for the fixture to cool down before replacing or serving.

FIXTURE OVERVIEW

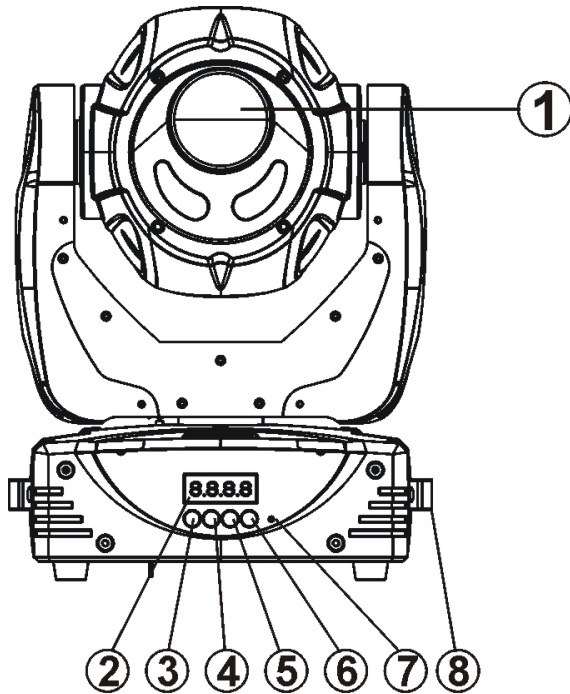

1. LED Assembly
2. LCD Menu Function Display
3. Mode/Esc Button
4. UP Button
5. DOWN Button
6. ENTER Button
7. Microphone
8. Carrying Handle(s)
9. 3Pin DMX Output
10. 3Pin DMX Input
11. 5Pin DMX Output
12. 5Pin DMX Input
13. Power Switch
14. Fuse Holder
15. Power Cord

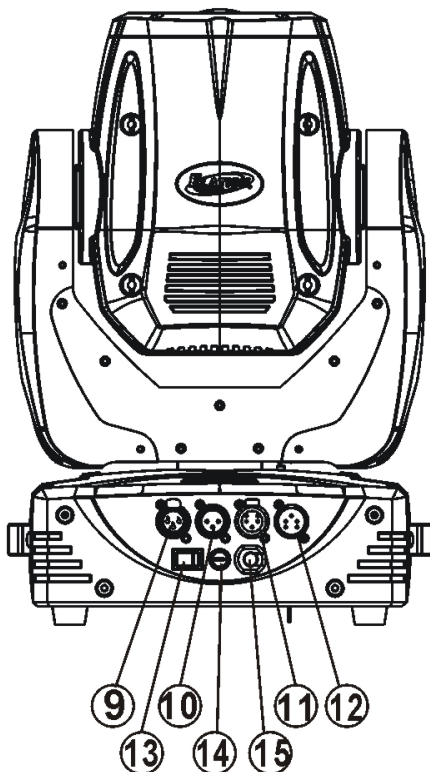

INSTALLATION



CAUTION!

Please consider the GB7000.15/EN60598-2-17 and the other respective national norms during the installation. The installation must only be carried out by a qualified person.



CAUTION!

The electric connection must only be carried out by a qualified electrician.



CAUTIONS

- For added protection, mount the fixture in areas outside walking paths, seating areas, or in areas where unauthorized personnel might reach the fixture.
- Before mounting the fixture to any surface, make sure the installation area can hold a minimum point load of 10 times the weight of the fixture. **(250 lbs / 113 kgs)**
- Fixture installation must always be secured with a secondary safety attachment, such as an appropriate safety cable.
- Never stand directly below the device when mounting, removing or servicing the fixture.
- Be sure the fixture is kept at least 0.5m (1.5 feet) away from any flammable materials (decoration etc.).

MOUNTING POINTS

- Overhead mounting requires extensive experience, including amongst others calculating working load limits, installation material being used, and periodic safety inspection of all installation material and the device. If you lack these qualifications, do not attempt the installation yourself. Improper installation can result in bodily injury.
- Fixture is fully operational in any mounting position, hanging upside-down, side mounted, or on any flat level surface, and will remain steady no matter the angle of the fixture.

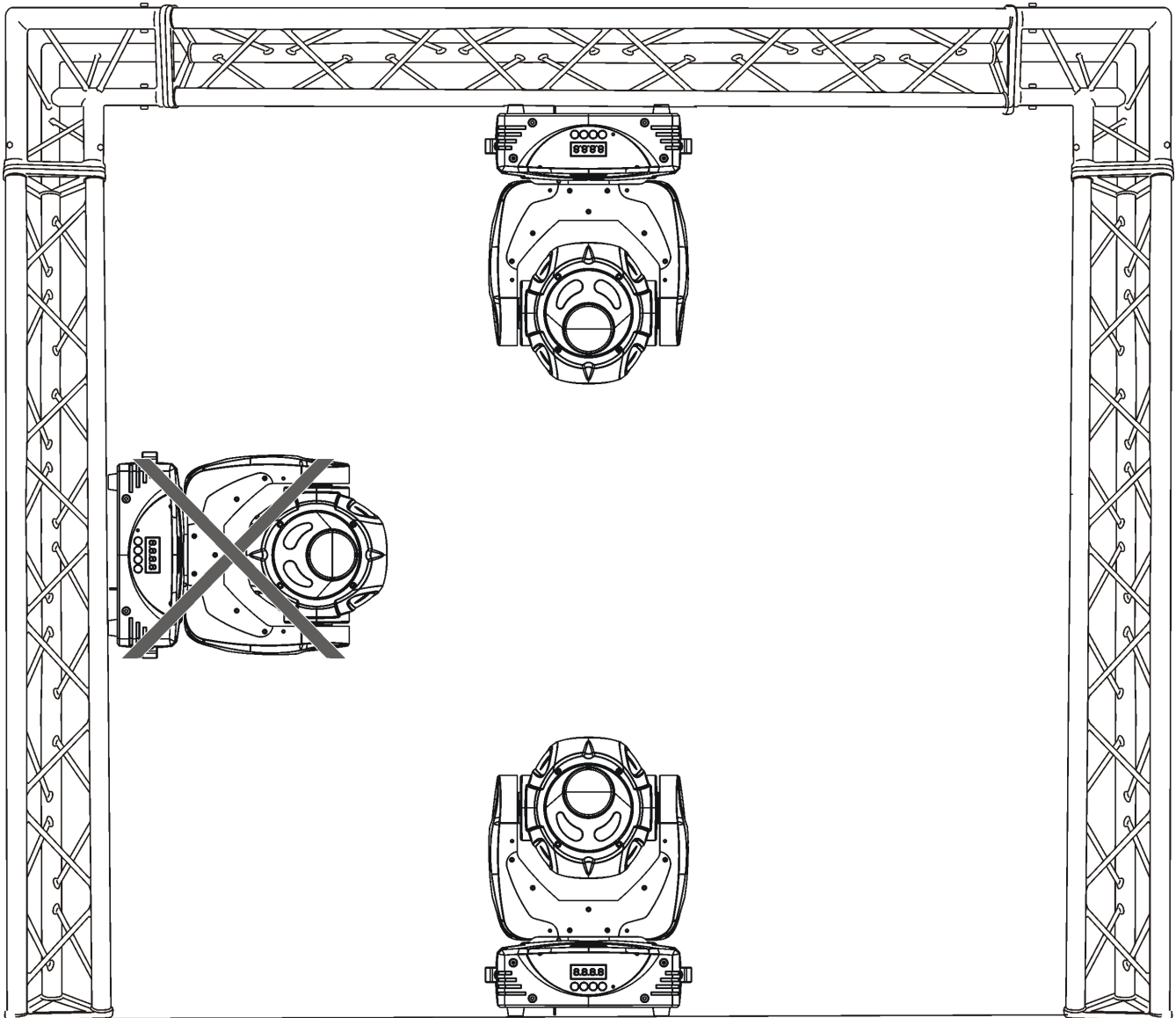

SAFETY CABLE

Always use a Safety Cable whenever installing this fixture in a suspended environment to ensure the fixture will not drop if the clamp fails.

CLAMP MOUNTING

The E SPOT LED II™ provides a unique mounting bracket assembly that integrates the bottom of the base, the included “Omega Bracket,” and the safety cable rigging point in one unit (see the illustration below). When mounting this fixture to truss be sure to secure an appropriately rated clamp to the included omega bracket using a M10 screw fitted through the center hole of the “omega bracket”. Be sure to attach the included safety cable to the fixture using the safety cable rigging point integrated in the base assembly.

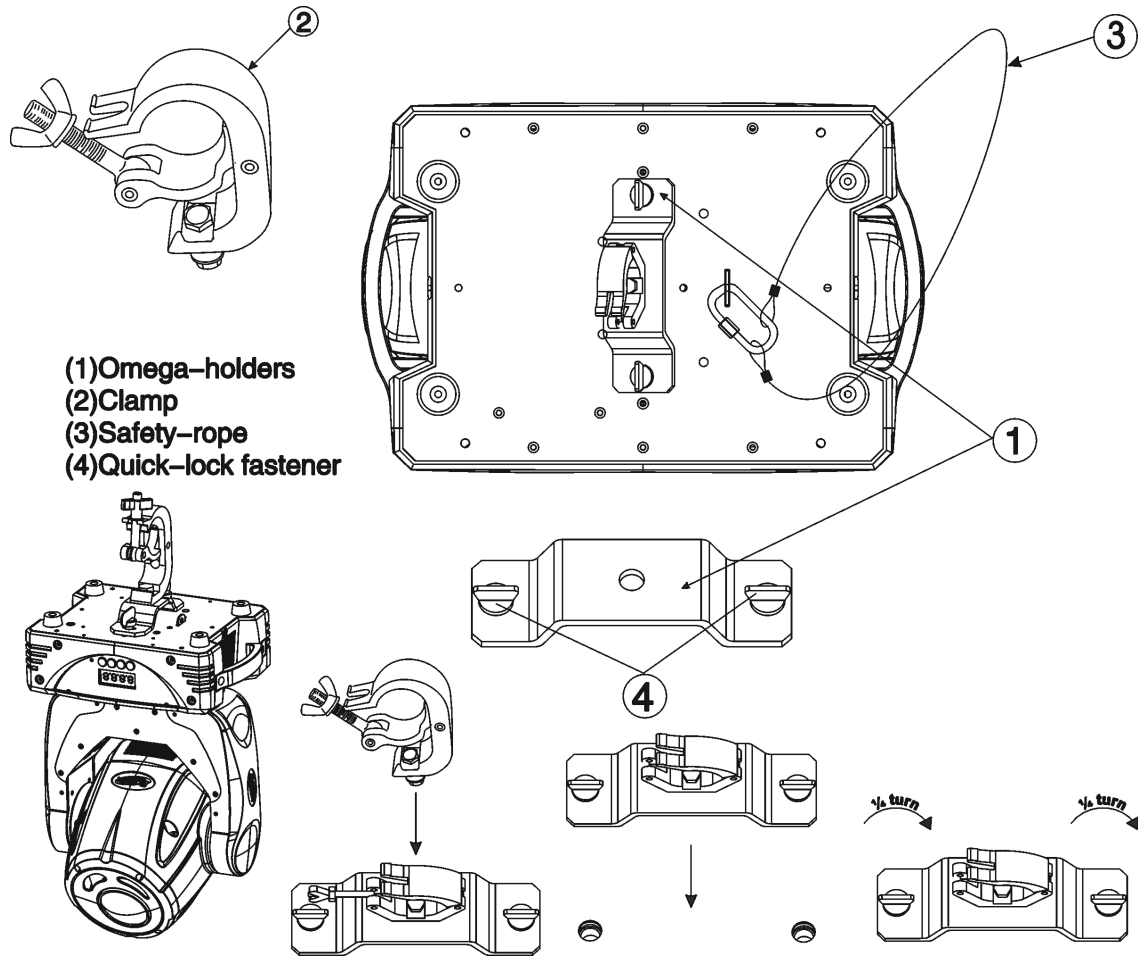

SECURING

Regardless of the rigging option you choose for your **E SPOT LED II™** always be sure to secure your fixture with a safety cable. The fixture provides a built-in rigging point for a safety cable on the hanging bracket as illustrated above. Be sure to only use the designated rigging point for the safety cable and never secure a safety cable to a carrying handle.

UNDERSTANDING DMX

DMX-512

DMX is short for Digital Multiplex. This is a universal protocol used by most lighting and controller manufactures as a form of communication between intelligent fixtures and controllers. DMX allows all makes and models of different manufactures to be linked together and operate from a single controller. This is possible as long as all the fixtures and the controller are DMX compliant. A DMX controller sends the DMX data instructions to the fixture allowing the user to control the different aspects of an intelligent light. DMX data is sent out as serial data that travels from fixture to fixture via data “IN” and data “OUT” XLR terminals located on the fixtures (most controllers will only have output jacks).

DMX LINKING

To ensure proper DMX data transmission, always use proper DMX cables and a terminator. When using several DMX fixtures try to use the shortest cable path possible. Never split a DMX line with a “Y” style connector. The order in which the fixtures are connected in a DMX line does not influence the DMX addressing. For example; a fixture assigned a starting DMX address of 1 may be placed anywhere in the DMX chain, at the beginning, at the end, or anywhere in the middle. The DMX controller knows to send data assigned to address 1 to that fixture no matter where it is located in the DMX chain. The **E SPOT LED II™** can be controlled via DMX-512 protocol and the DMX address is set via the control menu.

DATA CABLE (DMX Cable) REQUIREMENTS (For DMX and Master/Slave Operation)

Your fixture and your DMX controller require a standard 3pin or 5pin XLR connector for data input and data output (see figure below). If you are making your own cables, be sure to use two conductor, shielded digital DMX cable rated at 120 ohms; this cable is designed for DMX transmission and may be purchased from your Elation dealer or at most professional lighting retailers. Your cables should be made with a male and female XLR connector on either end of the cable. Also, remember that a DMX line must be daisy chained and cannot be split, unless using an approved DMX splitter such as **Elation’s Opto Branch 4™, Opto Branch 8™, or DMX-Branch/4™**.

DMX Output
3-Pin XLR Socket



DMX Input
3-Pin XLR Socket



- 1: Ground
- 2: Data (-)
- 3: Data (+)

DMX Output
5-Pin XLR Socket



DMX Input
5-Pin XLR Socket

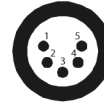

- 1: Ground
- 2: Data (-)
- 3: Data (+)
- 4: Open
- 5: Open



Be sure to follow the above figure when making your own cables. Do not use the ground lug on the XLR connector. Do not connect the cable's shield conductor to the ground lug or allow the shield conductor to come in contact with the XLR outer casing. Grounding the shield could cause a short circuit and erratic behavior.

DMX-512 CONTROLLER CONNECTION

Connect the provided XLR cable to the female XLR output of your controller and the other side to the male XLR input of the **E SPOT LED II™**. The diagram below illustrates a typical DMX-512 connection when the fixture is in the **14 Channel Extended Mode**. You can chain multiple panels together through serial linking. The cable that should be used is two conductor, shielded DMX cable with XLR input and output connectors. Always be sure daisy chain your in and out data connections, never split or “Y” your DMX connections unless you are using an approved DMX splitter such as **Elation’s Opto Branch 4™, Opto Branch 8™, or DMX-Branch/4™**.

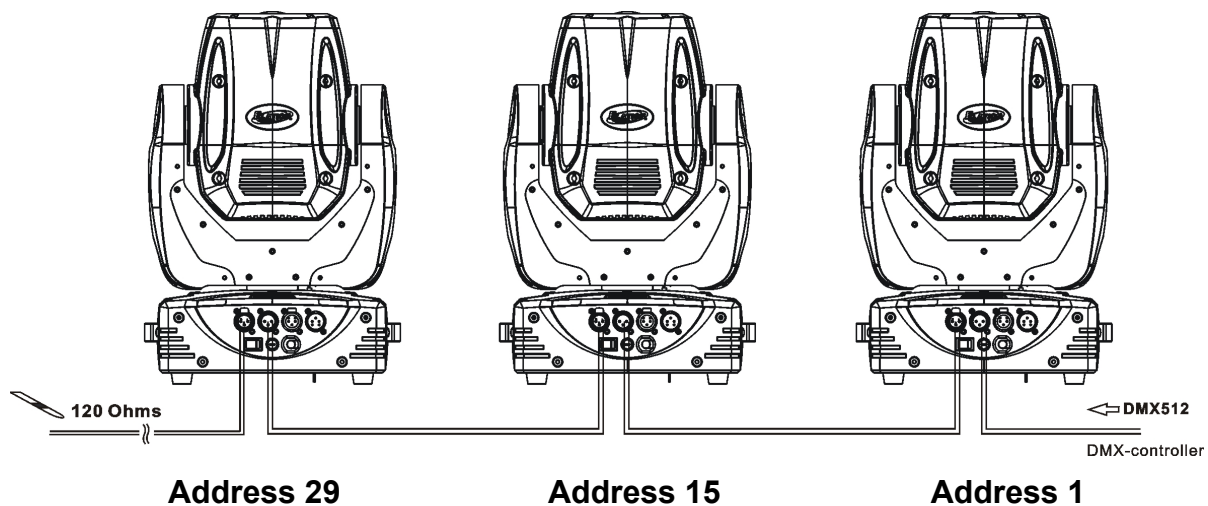

DMX-512 CONNECTION WITH DMX TERMINATOR

A DMX terminator should be used in all DMX lines especially in longer runs. The use of a terminator may avoid erratic behavior in your DMX line. A terminator is a 120 ohm 1/4 watt resistor that is connected between pins 2 and 3 of a male XLR connector (DATA + and DATA -). This fixture is inserted in the female XLR connector of the last fixture in your daisy chain to terminate the line. Using a line terminator will decrease the possibilities of erratic behavior.

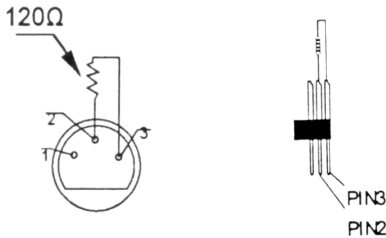

Termination reduces signal errors and avoids signal transmission problems and interference. It is always advisable to connect a DMX terminal, (Resistance 120 Ohm 1/4 W) between PIN 2 (DMX-) and PIN 3 (DMX +) of the last fixture.

5Pin XLR DMX CONNECTORS

Some manufactures use 5pin XLR connectors for DATA transmission in place of 3pin. 5pin XLR fixtures may be implemented in a 3pin XLR DMX line. When inserting standard 5pin XLR connectors in to a 3pin line a cable adaptor must be used, these adaptors are readily available at most electric stores. The following chart details a proper cable conversion.

3-Pin XLR to 5-Pin XLR Conversion		
Conductor	3-Pin XLR Female (Out)	5-Pin XLR Male (In)
Ground/Shield	Pin 1	Pin 1
Data Compliment (- signal)	Pin 2	Pin 2
Data True (+ signal)	Pin 3	Pin 3
Not Used		Pin 4 - Do Not Use
Not Used		Pin 5 - Do Not Use

DMX ADDRESSING

All fixtures should be given a DMX starting address when using a DMX controller, so the correct fixture responds to the correct control signal. This digital starting address is the channel number from which the fixture starts to “listen” to the digital control information sent out from the DMX controller. The allocation of this starting DMX address is achieved by setting the correct DMX address on the digital display located on the back of the fixture.

You can set the same starting address for all fixtures or a group of fixtures, or set different address for each individual fixture. Be advised that setting all fixtures to the same DMX address will subsequently control all fixtures in the same fashion, in other words, changing the settings of one channel will affect all the fixtures simultaneously.

If you set each fixture to a different DMX address, each unit will start to “listen” to the channel number you have set, based on the quantity of control channels (DMX channels) of each fixture. That means changing the settings of one channel will only affect the selected fixture.

In the case of the **E SPOT LED II™**, when in the **14 Channel Extended Mode** (default can also be set to 12 Channel Standard Mode), you should set the starting DMX address of the first unit to 1, the second unit to 15 (14 + 1), the third unit to 29 (14 + 15), and so on.

Note: During start-up the **E SPOT LED II™** will automatically detect whether a DMX data signal is being received or not. If DMX data signal is being received, the display will show "**Addr=XXX**" (**XXX** representing the actual DMX address). If the fixture is not receiving a DMX signal the display will flash. If your fixture is connected to a DMX controller and the display is flashing (not receiving a DMX signal), please check the following:

- The 3pin or 5pin XLR input plug (cable with DMX signal from controller) is not connected or is not inserted completely into the DMX input jack of the fixture.
- The DMX controller is switched off or defective.
- The DMX cable or connector is defective.
- A DMX terminator has been inserted into the last fixture in your DMX chain.

FIXTURE MENU

ON-BOARD SYSTEM MENU

The **E SPOT LED II™** comes with an easy to navigate system menu. The next section will detail the functions of each command in the system menu.

MENU FUNCTION DISPLAY

The control panel located on the base of the fixture allows you to access the main menu and make all necessary adjustments to the **E SPOT LED II™**. During normal operation, pressing the **MODE/ESC** key once will access the fixture's main menu. Once in the main menu you can navigate through the different functions and access the sub-menus with the **UP** and **DOWN** buttons. Once you reach a field that requires adjusting, press the **ENTER** button to activate that field and use the **UP** and **DOWN** buttons to adjust the field. Pressing the **ENTER** button once more will confirm your setting. Once a setting is saved the display will briefly readout **OK** to confirm a new setting has been made and locked into memory. You may exit the main menu at any time without making any adjustments by pressing the **MODE/ESC** button.



E SPOT LED II™ SYSTEM MENU				*Default Settings Shaded		
0	ADDR	AXXX	A001	Indicate the starting DMX address A001 also is the setting for slave		
1	TEST	T-01~T-XX		Automatically test the function		
2	PLAY	RUN	MSTR/ALON	Runs fixture as “master” or “alone” for auto		
		AUDI	MSTR/ALON	Runs fixture as “master” or “alone” for audio		
		AUTO	Clos/Hold/Auto/Audi	No DMX Status		
3	RESE	ALL		Reset all motors and returns fixture to home		
		SCAN		Reset only motors for pan/tilt		
		COLR		Reset only motors for colors		
		GOBO		Reset only motors for gobo and rotation		
		OTHR		Reset other motors		
4	TIME	LIFE	0000~9999	Displays the total fixture running time		
		CLMP		Clear LED running time		
5	RPAN	ON/OFF		Reverses the pan movements		
6	RTL	ON/OFF		Reverses the tilt movements		
7	FINE	ON/OFF		Switch 16 bit/8 bit		
8	DEGR	540/630		Pan degree select		
9	MIC	M-XX	M-70	Mic sensitivity		
10	DISP	VALU	D-XX	D-00 (DXXX)	Display the DMX512 value of each channel	
		D ON	ON/OFF		Display turn off after 2mins	
		FLIP	ON/OFF		This function will reverse the display 180	
		LOCK	ON/OFF		Key lock	
11	SPEC	RDMX	ON/OFF		Change DMX address via external controller	
		SPOT	ON/OFF		Lamp optimization	
		DFSE	ON/OFF		Resets all the fixture functions to default	
		FEED	ON/OFF		Pan/tilt feedback (error correction) on/off	
		FANS	AUTO/HIGH/LOW		Fan’s mode select	
		HIBE	OFF/1-99M	15M		Stand by mode
		VER	V1.0~V9.9			Software version
ADJU	CODE	CXXX		Fixture code *code is “C050”		
	CH01~CHXX	XXXX(-128~127)		Motor Fix		
12	EDIT	SEPR	AUTO	IP01~IP07	Select program to be edit	
		STEP	S-01	S-48	Set the amount of your program	
		SCXX	C-01~C-XX	XXX(0~255)		Edit the channels of each scene
			TIME	T XXX(001~999)		Time for each scene
			CEDT	ON/OFF		Edit program via controller
		REC.	RE.XX			Auto Save
		RUN	ON/OFF			Program test

MAIN FUNCTIONS

0. ADDRESS MENU

Addr A001 - A511 (Value) This is where you set the fixtures DMX address.

Setting/Changing the DMX Address

After applying power to the **E SPOT LED II™** the LED will display the fixture's current DMX address immediately after the reset sequence. If the fixture is not receiving a DMX signal the display will flash continuously. To set or adjust a DMX address, please follow the procedure below:

1. Switch on the **E SPOT LED II™** and wait for the fixture reset process to finished.
2. Press **MODE/ESC** to access the main menu. Toggle through the menu by pressing **UP** and **DOWN** until the display shows **A001**. Press **ENTER** to make changes to the DMX address; the current three-digit address will immediately begin to flash.
3. While the current three-digit address is flashing, press **UP** and **DOWN** to select adjust the address. Lock your new address into the unit's memory by pressing **ENTER**. After the new address has been successfully stored into the fixture's memory the LED will briefly readout **PASS**.

The DMX address is non-destructible and will remain in the fixture's memory even when power to the fixture has been switched off. Memory is backed-up and retained by an internal power source with a five year shelf life.

1. TEST MENU

TEST T-01 - T-XX (Test) Tests the functions of channel.

1. Access the main menu.
2. Press **UP** until "TEST" is displayed, press **ENTER**.
3. The display will read "T-01". You can now press **UP** and test the different channels. For example: If you press **UP** until "T-05" is displayed, the unit will test the color channel, changing the color one by one and show the rainbow effect with different speeds.
4. Press **MODE/ESC** to exit.

2. PLAY MENU

RUN

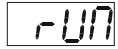

This feature is used to run the internal preset programs in either a **Master/Slave** or a **Stand-Alone** operating mode.

1. Access the main menu.
2. Press **UP** or **DOWN** until “**PLAY**” is displayed, press **ENTER**.
3. Press **UP** or **DOWN** until “**RUN**” is displayed, press **ENTER**.
4. Press **UP** or **DOWN** to select “**Master**” or “**Alone**” and press **ENTER**.
5. Press **MODE/ESC** to return to the main menu.

AUDI

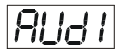

This feature is used to run the internal preset programs in AUDIO mode in either a **Master/Slave** or a **Stand-Alone** operating mode.

1. Access the main menu.
2. Press **UP** or **DOWN** until “**PLAY**” is displayed, press **ENTER**.
3. Press **UP** or **DOWN** until “**AUDI**” is displayed, press **ENTER**.
4. Press **UP** or **DOWN** to select “**Master**” or “**Alone**” and press **ENTER**.
5. Press **MODE/ESC** to return to the main menu.

AUTO

AUTO

Runs the unit without any DMX signal in **Stand-Alone** mode.

1. Access the main menu.
2. Press **UP** or **DOWN** until **“PLAY”** is displayed, press **ENTER**.
3. Press **UP** or **DOWN** until **“AUTO”** is displayed, press **ENTER**.
4. Press **UP** or **DOWN** to select **“CLOS”**, **“HOLD”**, **“AUTO”**, or **“AUDI”** and press **ENTER** to confirm.
5. Press **MODE/ESC** to return to the main menu.

This function dictates how the fixture will function if it loses DMX signal during normal operation. The default function is set to hold, in which the fixture will lock into the last DMX signal it received and remain in that position until it is turned off or begins receiving a new DMX signal. If the fixture is turned on without any DMX signal, the fixture will automatically go into sound-active mode. Available settings are: **“Close”** – Shutter flags will close. **“Hold”** – Fixture will remain at its last settings. **“Auto”** – Fixture will go into stand-alone mode, running the built-in program. **“Music”** – The fixture will go into sound-active mode.

3. RESE (RESET) MENU

RESE

ALL - Resets all the motors in the unit.

SCAN - Resets the Pan and Tilt motors.

COLR - (Color) - Resets the color motors.

GOBO - Resets the gobo motors.

OTHR - Reset all other motors

ALL

ALL

When you activate this reset function, **ALL** motors are reset.

1. Access the main menu.
2. Press **UP** until **“RESE”** is displayed, press **ENTER**.
3. Press **UP** until **“ALL”** is displayed, press **ENTER**.
4. Press **MODE/ESC** to return to the main menu.

SCAN



When you activate this reset function, only the **PAN** and **TILT** motors are reset.

1. Access the main menu.
2. Press **UP** until “**RESE**” is displayed, press **ENTER**.
3. Press **UP** until “**SCAN**” is displayed, then press **ENTER** to confirm.
4. Press **MODE/ESC** to return to the main menu.

COLR



When you activate this reset function, only the **Color Wheel** motor is reset.

1. Access the main menu.
2. Press **UP** until “**RESE**” is displayed, press **ENTER**.
3. Press **UP** until “**COLR**” is displayed, then press **ENTER** to confirm.
4. Press **MODE/ESC** to return to the main menu.

GOBO



When you activate this reset function, only the **Gobo Wheel** motor is reset.

1. Access the main menu.
2. Press **UP** until “**RESE**” is displayed, press **ENTER**.
3. Press **UP** until “**GOBO**” is displayed, press **ENTER** to confirm and begin the reset process.
4. Press **MODE/ESC** to return to the main menu.

OTHR

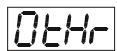

When you activate this reset function, only the motors not specified in the other reset commands previously listed are reset.

1. Access the main menu.
2. Press **UP** until “**RESE**” is displayed, press **ENTER**.
3. Press **UP** until “**OTHR**” is displayed, then press **ENTER** to confirm.
4. Press **MODE/ESC** to return to the main menu.

4. TIME MENU

TIME

LIFE - Displays the fixtures total running time.

CLMP - Clears the lamp running time.

LIFE

LIFE

With this function you can display the total running time of the fixture.

1. Access the main menu.
2. Press **UP** until "TIME" is displayed, press **ENTER**.
3. Press **UP** until "LIFE" is displayed, press **ENTER**.
4. Press **MODE/ESC** to return to the main menu.

CLMP

CLMP

With this function you can clear the running time of the LED.

Note: **Please clear the LED time every time you replace the LED.**

1. Access the main menu.
2. Press **UP** until "TIME" is displayed, press **ENTER**.
3. Press **UP** until "CLMP" is displayed, press **ENTER**.
4. Press **MODE/ESC**, the display will show "ON/OFF".
5. Press **UP** to select "ON" to activate or "OFF" to deactivate this function.
6. Press **ENTER** to confirm.
7. Press **MODE/ESC** to return to the main menu.

5. RPAN MENU

RPAN

This menu function will reverse the mirror **PAN** movements.

1. Access the main menu.
2. Press **UP** until "RPAN" is displayed, press **ENTER**.
3. The display will show "ON/OFF".
4. Press **UP** to select "ON" to activate or "OFF" to deactivate this function.
5. Press **ENTER** to confirm.
6. Press **MODE/ESC** to return to the main menu.

6. **RTLT MENU**

RTLT This menu function will reverse the mirror **TILT** movements.

1. Access the main menu.
2. Press **UP** until “**RTLT**” is displayed, press **ENTER**.
3. The display will show “**ON/OFF**”.
4. Press **UP** to select “**ON**” to activate or “**OFF**” to deactivate this function.
5. Press **ENTER** to confirm.
6. Press **MODE/ESC** to return to the main menu.

7. **FINE MENU**

FINE This menu item switches between 16bit (fine) and 8bit (coarse) modes. When this function is turned on the fixture will operate in 16bit (fine) mode. When functioning in 16bit mode the fixture will use 16 DMX channels, when the 16bit function is turned off the fixture will use 14 DMX channels.

1. Access the main menu.
2. Press **UP** until “**FINE**” is displayed, press **ENTER**.
3. The display will show “**ON/OFF**”.
4. Press **UP** to select “**ON**” to activate or “**OFF**” to deactivate this function.
5. Press **ENTER** to confirm.
6. Press **MODE/ESC** to return to the main menu.

8. DEGR MENU

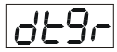

This menu function changes the maximum amount of PAN movement from either **630°** or **540°**. When turned ON, the fixture will operate with a PAN movement of **540°**. A maximum of **540°** PAN movement will allow for a quicker response in PAN movement.

1. Access the main menu.
2. Press **UP** until “**DEGR**” is displayed, press **ENTER**.
3. The display will display “**630/540**”.
4. Press **UP** or **DOWN** to select “**630**” or “**540**” Pan movement angle, default is **540°**
5. Press **ENTER** to confirm.
6. Press **MODE/ESC** to return to the main menu.

9. MIC MENU



This function allows for electronic control of the internal microphone’s sound sensitivity.

1. Access the main menu.
2. Press **UP** until “**MIC**” is displayed and press **ENTER**.
3. The display will show “**M-XX**” (Where XX represents a value between 00 & 99).
4. Press **UP** and **DOWN** to adjust the **MIC** sensitivity, 99 being the highest.
5. Press **ENTER** to confirm and lock your new setting in place.
6. Press **MODE/ESC** to return to the main menu.

10. DISPLAY MENU

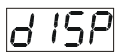

This menu function will control the various on-board display features.

VALU - Displays the DMX channel value

D ON - Display auto on/off command

FLIP - Display rotation

LOCK - Menu function button lock

VALU

VALU This function will display the DMX value of a channel as a DMX control console changes it.

1. Access the main menu.
2. Press **UP** until “**DISP**” is displayed.
3. Press **ENTER**, the display will show “**VALU**”.
4. Press **ENTER**, once again “**d-00**” will be displayed.
5. Press **ENTER** to confirm.
6. Press **MODE/ESC** to return to the main menu.

DON

DON This function will turn the display off after two seconds without any menu activity.

1. Access the main menu.
2. Press the **UP** until “**DISP**” is displayed.
3. Press **ENTER**, the display will show “**VALU**”.
4. Press **UP** until “**D-ON**” is displayed and press **ENTER**.

Press **UP** to select “**ON**” to activate this function, or “**OFF**” to deactivate this function. When set “**OFF**”, this function will turn the display off after the display has gone two seconds without any menu activity.

5. Press **ENTER** to confirm.
6. Press **MODE/ESC** to return to the main menu.

FLIP

FLIP This function will reverse the display readout by **180°**.

1. Access the main menu.
2. Press **UP** until “**DISP**” is displayed.
3. Press **ENTER**, the display will show “**VALU**”.
4. Press **UP** until “**FLIP**” is displayed and tap the **ENTER** button.
5. Press **UP** to select “**ON**” to activate or “**OFF**” to deactivate this function.
6. Press **ENTER** to confirm.
7. Press **MODE/ESC** to return to the main menu.



LOCK This function allows you to lock the keys on the display to prevent menu tampering. With this function you can activate the automatic key lock function. If this function is activated, the keys will be automatically locked in 15 seconds from the last command. In order to deactivate or temporarily deactivate the key lock function, press the **MODE/ESC** for 3 seconds to regain access to the menu commands.

1. Access the main menu.
2. Press **UP** until “**DISP**” is displayed.
3. Press **ENTER**, the display will show “**VALU**”.
4. Press **UP** until “**LOCK**” is displayed and tap the **ENTER**.
5. Press **UP** to select “**ON**” to activate or “**OFF**” to deactivate this function.
6. Press **ENTER** to confirm.
7. Press **MODE/ESC** to return to the main menu.

11. SPEC MENU This menu option access all the special functions listed below.

RDMX - Allows DMX address to be changed via and external DMX controller.

SPOT - This provides a spot beam for better lamp optimization.

DFSE (Default) - Resets the unit to all default settings.

FEED - This function turn the DMX correction feature “**ON**” (default) or “**OFF**.”

FANS- Changes the functionality of the built-in fans.

HIBE – This function control the fixture stand-by mode

VER (Version) - Displays the software version.

ADJU – Calibration functions

RDMX



This function allows the DMX address to remotely be adjusted from a DMX console. This setting requires special settings for both the controller and the fixture. RDMX is on by default.

SPOT



This function allows you to optimize the lamp without the use of an external DMX controller. In this mode, the device will not react to any control signal.

1. Access the main menu.
2. Press **UP** until “**SPEC**” is displayed, press **ENTER**.
3. Press **UP** until “**DFSE**” is displayed, press **ENTER**.
4. The display will show “**ON/OFF**”.
5. Press **UP** to display “**ON**” to activate or “**OFF**” to deactivate this function.
6. Press **ENTER** to confirm.
7. Press **MODE/ESC** to return to the main menu.

DFSE



With this function you can restore the factory default settings of the fixture. All settings will be set back to the default values. Any edited scenes will be lost. When restoring the factory settings the unit must be set to the address that the unit was in when you started editing. ***When you confirm this function, the fixture will begin to reload the original factory settings.***

1. Access the main menu.
2. Press **UP** until “**SPEC**” is displayed, press **ENTER**.
3. Press **UP** until “**DFSE**” is displayed, press **ENTER**.
4. The display will show “**ON/OFF**”.
5. Press **UP** to display “**ON**” to activate or “**OFF**” to deactivate this function.
6. Press **ENTER** to confirm.
7. Press **MODE/ESC** to return to the main menu.

FEED

 Use this function to activate the **PAN/TILT** error correction.

1. Access the main menu.
2. Press **UP** until “**SPEC**” is displayed, press **ENTER**.
3. Press **UP** until “**FEED**” is displayed, press **ENTER**.
4. The display will show “**ON/OFF**”.
5. Press **UP** to display “**ON**” to activate or “**OFF**” to deactivate this function.
6. Press **ENTER** to confirm.
7. Press **MODE/ESC** to return to the main menu.

FANS

 This function is used to change the functionality of the internal cooling fans.

1. Access the main menu.
2. Press **UP** or **DOWN** until “**SPEC**” is displayed, press **ENTER**.
3. Press **UP** or **DOWN** until “**FANS**” is displayed, press **ENTER**.
4. The display will show “**HIGH/AUTO**”.
5. Press **UP** or **DOWN** to select “**HIGH**” or “**AUTO**”.
6. Press **ENTER** to confirm.
7. Press **MODE/ESC** to return to the main menu.

Hibernation

 When activated, this function will put the fixture in power stand-by mode. This function will automatically activate after a predefined period of time of no DMX activity. This prevents the fixture from expending power for extended periods in the event the fixture has been left on accidentally. In stand-by mode the lamp and all motors will power down if no DMX signal is sent to the fixture for a period of 15 minutes (default, or can be user defined). The fixture will automatically reset and return to normal operation once a DMX signal is sensed.

1. Select “**HIBE**” by pressing **UP** or **DOWN**.
2. Press **ENTER** and press **UP** or **DOWN** to adjust the time value from “**15M**” (default value) to any value from 1 minute (**01M**) to 99 minutes (**99M**), or “**OFF**”.
3. Press **ENTER** to confirm the new value **MODE/ESC** to return to the main menu without making any changes.

VER

 Use this function to display the Software version of the unit.

1. Access the main menu.
2. Press **UP** until “**SPEC**” is displayed, press **ENTER**.
3. Tap **UP** until “**VER**” is displayed, press **ENTER**.
4. The display will show “**V-1.0**”, the display may also show, “**V-2.0**”, “**V-9.9**” etc.
5. Press **ENTER** or **MODE/ESC** to exit.

ADJU

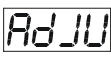
 This function is used to calibrate the various internal motors in the event the internal homing mechanism become slightly out of adjustment. This function is protected with a password to prevent unauthorized personal from tampering with the fixture.

1. Access the main menu.
2. Press **UP** or **DOWN** until “**ADJU**” is displayed, then press **ENTER**.
3. Press **UP** or **DOWN** until “**CODE**” is displayed, then press **ENTER**.
4. The display will show “**CXXX**”, were as “**XXX**” represents the calibration password. The calibration password is “**C050**”. Use **UP** or **DOWN** to enter the proper password.
5. Once the proper password is entered the display will read “**CHXX**”, were as “**XX**” represents the fixture channel number, in the case of the **E SPOT LED II™ 1 ~ 16**.
6. Select the desired channel to be calibrated by pressing **UP** or **DOWN** and then **ENTER** to confirm.
7. The display will then read “**xxxx**”, were “**xxxx**” stands for the calibrate values.
8. Adjust the desired calibration value between –128 and 127 by pressing **UP** and **DOWN**. As you scroll up and down through the calibration values you will notice slight changes in the wheel or motor you are attempting to calibrate.
9. Once you reach your desired calibration press **ENTER** to confirm and lock in your calibration.

12. EDIT MENU

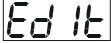
 This menu item allows you to write a program into the fixture's internal memory (**EEPROM**) via the control panel or via an external DMX controller. For more information on using the built-in DMX controller see "**Working with Built-In Programs**" section page 36.

SEPR- Select program to be edit.

STEP (S-01 - S-48) - These are the Step slots (**48 total**) you write your programs into.

STXX (SC01 – SC48) - These are the Scenes (**48 total**) stored in your program.

C-01 - C-11 (Channel 1 - Channel 11) - Represents the total fixture channels for each scene that can be edited.

TIME (Time) - Running time of the entire program.

CEDT - Edit program using a external controller.

REC – Auto save function.

RUN – Program test mode.

SEPR

 Select a program to be edited.

STEP

 Program the number of steps in your individual Program.

SC01

 Set the total number of scenes in your internal Program.

RUN

 Allows you to "**RUN**" the user-installed program. You can set the number of steps under "**STEP**" (**S-01- S-48**), and you can edit the individual scenes under "**EDIT**".

DMX ADDRESSING

Setting the DMX Address - After the fixture is turned “ON” it will immediately complete a reset process that tests all the fixture’s functions. When the reset process concludes the LCD will display the fixture’s current DMX address. If the fixture is not receiving a DMX signal, the display will flash continuously. To set or adjust a DMX address, please follow the procedure below:

1. Toggle through the menu by pressing **UP** and **DOWN** until the display reads “**Addr=XXX**”. Press **ENTER** to make changes to the address.
2. While the display is flashing use **UP** and **DOWN** to select a new address. Once the new address has been selected, lock the new address into the fixture’s memory by pressing **ENTER**.

The DMX address is non-volatile and will remain in the fixture’s memory even when the power to the unit is switched off. Memory is backed-up and retain by an internal power source that should last about five years.

Remote DMX addressing (RDMX) / Address Via DMX- This function allows the DMX address to be changed remotely from a DMX console. This setting requires special settings for both the controller and the fixture, and may be turned ON and OFF. (“ON” = default)

Fixture Settings:

1. Access the main menu and use **UP** or **DOWN** to get to the “**Personality**” menu, then press **ENTER**.
2. Once in the “**Personality**” menu, press **UP** or **DOWN** to get to the “**Status Settings**” menu, press **ENTER**.
3. Once in the “**Status Settings**” press **UP** or **DOWN** to get to the “**Address via DMX**” function and press **ENTER**.
4. “**Address via DMX**” is the function that turns the RDMX function ON and OFF. Press **ENTER** and be sure the function is turned on.
5. Press **UP** to display “**ON**” to activate or “**OFF**” to deactivate this function.
6. Press **ENTER** to confirm.
7. Press **MODE/ESC** to return to the main menu.

Controller Settings:

1. Set the DMX value of **Channel 1** to a value of 7.
2. Set the DMX value of **Channel 2** to a value of 7 or 8. When **Channel 2** is set to "7" you can adjust the starting address between 1 and 255. When set to "8" you can adjust the starting address between 256 and 511.
3. Use **Channel 3** to set your desired DMX starting address.
4. Wait for approximately 20 seconds for the unit to complete the address reset function.

Example 1:

If you want to set the starting address to 57, set **Channel 1** to a value of "7", set **Channel 2** to a value of "7" and use **Channel 3** to set your address to 57 by selecting a channel value of 57.

Example 2:

If you want to set the starting address to 420, set **Channel 1** to a value of "7", **Channel 2** to "8" and **Channel 3** to "164" (256+164=420).

Operation

Operating Modes: The **E SPOT LED II™** can operate in six different modes. This next section will detail the differences in the operating modes.

- **Auto Program Mode (Master)** - The fixture will chase through the built-in programs, sending a DMX control signal to all other fixtures connect via DMX cables instruction for a synchronized light show.
- **Auto Program Mode (Stand-Alone)** - The fixture will chase through the built-in program. This feature is great for store front with custom logos, where as the logos need to be displayed but the use of a controller is unwanted.
- **Music Control Mode (Stand-Alone)** - The fixture will react to sound, chasing through the built-in programs. Great for small clubs or DJ that do not want to bother with programming.
- **Music Control Mode (Master/Slave)** - You can daisy chain up to 16 fixtures together to get a synchronized light show without the need of an external controller. The fixtures will react to sound, chasing to a synchronized light show.
- **Set To Slave** – This function will set the fixture to slave mode for use in either the auto program or music control program modes
- **DMX Control Mode** - This function will allow you to control each individual fixtures traits with a standard DMX-512 controller such as the **Elation® Show Designer 2™**.

Stand-Alone Operation (Auto Program or Music Control): This mode allows a single fixture to run to the built-in programs with or without sound. Only use this mode when running a single fixture, or when running several fixtures as individuals.

- **For Functionality Without Sound Control:** Access the “**Function**” menu and select the “**Auto Program**” function, this will give you access to the “**Auto Program**” submenu. See page 18 for the menu breakdown. Once in the “**Auto Program**” submenu select “**Alone**”.
- **For Functionality With Sound Control:** Access the “**Function**” menu and select the “**Music Control**” function, this will give you access to the “**Music Control**” submenu. See page 18 for the menu breakdown. Once in the “**Music Control**” submenu select “**Alone**”.

Master/Slave Operation (Auto Program or Music Control): This function allows up to 16 fixtures to be linked together to provide a synchronized light show without the use of a controller. Only use this when linking several fixtures together for use without a controller. Any fixture can act as a “**Master**” or a “**Slave**”.

- Using XLR DMX cables, daisy chain your fixtures together via the XLR connectors. Remember the Male XLR connector is the input and the Female XLR connector is the output. The first fixture in the chain (master) will use the female XLR connector only - The last fixture in the chain will use the male XLR connector only. For longer cable runs we suggest a terminator at the last fixture.
- For the unit functioning as the “**Master**” unit follow the same procedures listed in the previous Stand-Alone section.
- For the “**Slave**” units, access the “**Set To Slave**” settings in the “**Function Mode**” menu and assign each slave fixture a designation (**Slave 1, Slave 2, Slave 3...etc.**).

Universal DMX Control: This function allows you to use a universal DMX-512 controller such as the **Elation® Show Designer 2™** or **Elation® Show Designer 3™** to control head movement, the color wheel, the shutter (strobe), and all other DMX traits. A DMX controller allows you to create unique programs tailored to your individual needs. The **E SPOT LED II™** uses 14 (default) DMX channels. See page 39 for detailed description of the DMX traits. To control your fixture in DMX mode, follow the set-up procedures on pages 13-16 as well as the set-up specifications that are included with your DMX controller. Use the controller’s faders to control the various DMX fixture traits. This will allow you to create your own programs.

- Follow the instruction on page 32 to set the DMX address.
- Be sure to use a terminator on the last fixture, especially for longer cable runs (more than a 100 feet).
- For help operating fixture in DMX mode consult the manual that was included with your DMX controller.

WORKING WITH BUILT-IN PROGRAMS

The fixture comes equipped with a built-in DMX recorder that allows custom programs to be installed and recalled directly from the fixture's control board. Programs can be created and stored using the fixture's control board or by using an external DMX controller. The following instructions will detail the procedures for using the on-board system menu as well as using a DMX compliant controller.

Memory Statistics:

Quick Access Programs (Program Part): 3

Total Number of Programs: 10

Maximum Number of Steps (Scenes) per a Program: 64

Total Number of Scenes (Steps): 250

Step 1 – Building Scenes.

The control will store a maximum of 250 scenes. These scenes are then used to create the programs. A program can store one or a maximum of 64 scenes. Keep in mind that a scene can only be access when it is stored in a "Program." If you wish to build a static scene (a scene consisting of no movement) for a logo or gobo projection, the scene must be stored inside a program.

- Access the main menu and toggle to "**Edit Programs**" which is menu function 12.
- Then press **ENTER** and toggle to "**Edit Scenes**", menu function 12-3.
- When you get to the "**Edit Scenes**" function press **ENTER**. The screen will then change to "**Edit Scene 001**". You can then press **ENTER** to begin to edit Scene 1 or use **UP** and **DOWN** to toggle to access Scenes 2-250.
- In the Scene Edit screen you have access to the functions listed below. Pressing **ENTER** will instantly allow you to change the values of the selected function in real time. The values can be adjusted from 0~250. Once you achieved your desired value press **ENTER** once again to automatically lock the value into the scenes memory. You can repeat the procedure for all functions listed below:

- **“Auto Program”** – Allows access to all 14 of the fixture’s DMX traits.
- **“PAN”** – pan movement.
- **“PAN-Fine”** – precision pan movement.
- **“TILT”** – tilt movement.
- **“TILT-Fine”** – precision tilt movement
- **“Move Speed”** – adjust pan and tilt motor speed
- **“Gobo Wheel 1”** – select gobos from gobo wheel 1
- **“Gobo Rot. 1”** – adjust gobo 1 indexing or rotation
- **“Prism”** – select a prism, prism macro, or frost
- **“Prism Rot.”** – adjust the prism indexing or rotation
- **“Color Wheel”** – select a color from the color wheel
- **“Focus”** – adjust the focus value
- **“Strobe”** – adjust the strobe
- **“Dimmer”** – adjust the dimmer intensity
- **“Scene Time”** – set the hold time for the scene
- **“Input By Out”** – this function will store a scene from an external DMX console. See the next section for scene editing via an external DMX controller.

Step 1B – Building Scenes from an External DMX Controller

The fixture includes a simple built-in DMX recorder. This recorded allow you to build a scene using your own DMX console and then send that scene to the fixture to be stored inside one of the fixture scene storage banks. Many people may find this procedure easier and quicker than using the on board menu functions as in “Step 1.”

- Using your DMX control build and store scenes as you normally would.
- Once you have built all your required scenes, enter the fixtures main menu and toggle to

Step 2 – Editing Programs.

The control will store a maximum of 10 programs. A program can store one or a maximum of 64 scenes. Keep in mind that a scene can only be access when it is stored inside one of the 10 available programs.

- Access the main menu and toggle to “**Edit Programs**” which is menu function 12.
- Then press **ENTER** and toggle to “**Program 1**”.
- When you get to the “**Program 1**” function press **ENTER**. The screen will then change to “**Edit Steps 01**”. Use **UP** and **DOWN** to toggle through the scenes created in “**Step 1**”. Press **ENTER** to add a scene to the program. Pressing **ENTER** will automatically lock the selected scene into the programs’ memory. Repeat the process until all the desired scenes have been added to the program. Each program can store a maximum of 64 scenes.
- To test the program, access “**Program Test**” in the “**Program Edit**” menu function.

Step 3 – Playing a Program

To initiate a program follow the procedure below:

- Access the main menu and press **UP** and **DOWN** to toggle to “**Function Mode**” and press **ENTER**.
- In the next screen select “**Auto Program**” and press **ENTER**.
- There are now two selections, “**Master**” and “**Alone**”. Select “**Master**” when running multiple fixtures in a **Master/Slave** configuration. See “**Master/ Slave Operation**” section on page 35 for proper set-up instructions. Select “**Alone**” when running a single fixture or when multiple fixtures in stand-alone mode. See “**Stand-Alone Operation**” section on page 34 for proper set-up instructions.

DMX CHANNEL FUNCTIONS AND VALUES

ELATION® E SPOT LED II™			
DMX Channel Values / Functions (14 DMX Channels)			
Specifications are subject to change without any prior written notice.			
MODE / CHANEL		VALUE	FUNCTION
STAND	BASIC		
1	1		PAN MOVEMENT [8 BIT]
		0-255	PAN Movement
2			PAN FINE MOVEMENT [16 BIT]
		0-255	Fine Control of PAN Movement
3	2		TILT MOVEMENT [8 BIT]
		0-255	TILT Movement
4			TILT MOVEMENT [16 BIT]
		0-255	Fine Control of TILT Movement
5	3		COLOR WHEEL
		0-14	OPEN / WHITE
		15-29	RED
		30-44	BLUE
		45-59	GREEN
		60-74	YELLOW
		75-89	MAGENTA
		90-104	ORANGE
		105-119	LIGHT BLUE
		120-127	PINK
		128-189	Forward Color Effect from FAST to SLOW
		190-193	NO Rotation
194-255	Backward Color Effect from SLOW to FAST		
6	4		ROTATING GOBOS, CONTINOUS ROTATION
		0-9	OPEN
		10-19	Rotating Gobo 1
		20-29	Rotating Gobo 2
		30-39	Rotating Gobo 3
		40-49	Rotating Gobo 4
		50-59	Rotating Gobo 5
		60-69	Rotating Gobo 6
		70-79	Rotating Gobo 7
		80-95	Gobo 1 Shake SLOW to FAST
		96-111	Gobo 2 Shake SLOW to FAST
		112-127	Gobo 3 Shake SLOW to FAST
		128-143	Gobo 4 Shake SLOW to FAST
		144-159	Gobo 5 Shake SLOW to FAST
		160-175	Gobo 6 Shake SLOW to FAST
		176-191	Gobo 7 Shake SLOW to FAST
		192-255	Gobo Wheel Rotation Backward from SLOW to FAST
		7	5
0-127	Gobo Indexing		
128-189	Forward Gobo Rotation from FAST TO SLOW		
190-193	NO Rotation		
194-255	Backward Gobo Rotation from SLOW to FAST		

ELATION® E SPOT LED II™ DMX Channel Values / Functions (14 DMX Channels)			
Specifications are subject to change without any prior written notice.			
MODE / CHANEL		VALUE	FUNCTION
STAND	BASIC		
8	6		ROTATING PRISM, PRISM / GOBO MACROS
		0-31	OPEN
		32-63	3-Facet Prism
		64-95	Infinite (Trapezoid) Prism
		96-127	5-Facet Prism
		128-135	Prism/Gobo Macro 1
		136-143	Prism/Gobo Macro 2
		144-151	Prism/Gobo Macro 3
		152-159	Prism/Gobo Macro 4
		160-167	Prism/Gobo Macro 5
		168-175	Prism/Gobo Macro 6
		176-183	Prism/Gobo Macro 7
		184-191	Prism/Gobo Macro 8
		192-199	Prism/Gobo Macro 9
		200-207	Prism/Gobo Macro 10
		208-215	Prism/Gobo Macro 11
		216-223	Prism/Gobo Macro 12
224-231	Prism/Gobo Macro 13		
232-239	Prism/Gobo Macro 14		
240-247	Prism/Gobo Macro 15		
248-255	Prism/Gobo Macro 16		
9	7		ROTATING PRISM, INDEX ROTATION
		0-127	Prism Indexing
		128-189	Forward Prism Rotation from FAST to SLOW
		190-193	NO Rotation
		194-255	Backward Prism Rotation from SLOW to FAST
10	8		FOCUS
		0-255	Continuous Adjustment from NEAR to FAR
11	9		SHUTTER, STROBE
		0-31	Shutter CLOSED
		32-63	NO Function (Shutter OPEN)
		64-95	Strobe Effect SLOW to FAST
		96-127	NO function (Shutter OPEN)
		128-159	Pulse Effect In Sequences
		160-191	NO Function (Shutter OPEN)
		192-223	Random Strobe Effect SLOW to FAST
		224-255	NO Function (Shutter OPEN)
12	10		DIMMER INTENSITY
		0-255	Intensity 0 to 100%
13	11		PAN / TILT MOVEMENT SPEED
		0-225	MAX to MIN Speed
		226-235	Movement Triggers BLACKOUT
		236-245	Wheel Movement Triggers BLACKOUT
		246-255	NO Function

ELATION® E SPOT LED II™ DMX Channel Values / Functions (14 DMX Channels)			
<small>Specifications are subject to change without any prior written notice.</small>			
MODE / CHANEL		VALUE	FUNCTION
STAND	BASIC		
14	12		RESET, INTERNAL PROGRAMS
		0-19	Color & Gobo Change Normal
		20-29	Color Change to Any Position (Split Colors)
		30-39	Color & Gobo Change to Any Position (Split Colors)
		40-59	NO Function
		60-79	NO Function
		80-84	ALL Motor Reset
		85-87	SCAN Motor Reset
		88-90	COLORS Motor Reset
		91-93	GOBOS Motor Reset
		94-96	NO Function
		97-99	OTHER Motor Reset
		100-119	Internal Program 1 (Scene 1-8)
		120-139	Internal Program 2 (Scene 9-16)
		140-159	Internal Program 3 (Scene 17-24)
		160-179	Internal Program 4 (Scene 25-32)
		180-199	Internal Program 5 (Scene 33-40)
200-219	Internal Program 6 (Scene 41-48)		
220-239	Internal Program 7 (Scene 49-56)		
240-255	Sound Control (Scene of Program 1)		

ERROR CODES

When power is applied, the unit will automatically enter a “**Reset/Test**” mode. This mode brings all the internal motors to a home position. If there is an internal problem with one or more of the motors an error code will flash in the display in the form of “**XXer**” where as XX will represent a function number. For example, when the display shows “**0Er**” it means there is some type of error with the Pan motor. If there are multiple errors during the start-up process they will all flash in the display. For example: if the fixtures has errors on channel 1, **Channel 2**, and **Channel 5** all at the same time, you will see the error message “**01Er**”, “**02Er**”, and “**05Er**” flash repeated 5 times.

If an error does occur during the initial start-up procedure the fixture will self-generate a second reset signal and try to realign all the motors and correct the errors, if the error persists after a second attempt a third attempt will be made.

If after a third attempt all the errors have not been corrected the fixture will make the following determinations:

- 1) 3 or more errors - The fixture cannot function properly with three or more errors therefore the fixture will place itself in a stand-by mode until subsequent repairs can be made.
- 2) Less than 3 errors - The fixture has less than 3 errors, therefore most other functions will work properly. The fixture will attempt to operate normally until the errors can be corrected by a technician. The errors in question will remain flashing in the display as a reminder of internal errors.

PAN Error: The yoke is not located in the default position after start-up or after a reset command. This message will appear after a fixture reset if the pan’s magnetic-indexing circuit malfunctions (sensor failed or magnet is missing) or there is a motor failure (defective motor or a defective motor IC drive on the main PCB). This error may also be displayed if the head/yoke was blocked during a reset function.

TILT Error: This message will appear after a fixture reset if the tilt’s magnetic-indexing circuit malfunctions (sensor failed or magnet is missing) or there is a motor failure (defective motor or a defective motor IC drive on the main PCB). This error may also be displayed if the head was blocked during a reset function.

Color-Wheel Error:

The color wheel is not located in the default position after start-up or after a reset command. This message will appear after a fixture reset if the color wheel's magnetic-indexing circuit malfunctions (sensor failed or magnet is missing) or there is a stepper motor failure (defective motor or a defective motor IC drive on the main PCB).

Rotating Gobo-Wheel Error:

The gobo-wheel is not located in the default position after start-up or after a reset command. This message will appear after a fixture reset if the gobo wheel's magnetic-indexing circuit malfunctions (sensor failed or magnet is missing) or there is a stepper motor failure (defective motor or a defective motor IC drive on the main PCB).

Rotating Gobo Indexing Error:

The gobo is not located in the default position after start-up or after a reset command. This message will appear after a fixture reset if the gobo positioning magnetic-indexing circuit malfunctions (sensor failed or magnet is missing) or there is a stepper motor failure (defective motor or a defective motor IC drive on the main PCB).

Prism-Wheel Error

This message will appear after the reset of the fixture and if the magnetic-indexing circuit malfunctions (sensor failed or magnet missing) or the stepping-motor is defective (or its driver circuit on the main PCB). The Prism wheel is not located in the default position after the reset.

Focus-Error

This message will appear after the reset of the fixture and if the magnetic indexing circuit malfunctions (sensor failed or magnet missing) or the stepping-motor is defective (or its driver circuit on the main PCB). The focus motor is not located in the default position after the reset.

CLEANING AND MAINTENANCE



CAUTION!

Disconnect from mains before starting maintenance operation.

CLEANING

Frequent cleaning is recommended to insure proper function, optimized light output, and an extended life. The frequency of cleaning depends on the environment in which the fixture operates: damp, smoky or particularly dirty environments can cause greater accumulation of dirt on the fixture's optics.

- Clean the external lens surface at least every 20 days with a soft cloth to avoid dirt/debris accumulation.
- Never use alcohol, solvents, or ammonia based cleaners.

MAINTENANCE

Regular inspections are recommended to insure proper function and an extended life.

There are no user serviceable parts inside this fixture, please refer all other service issues to an authorized Elation service technician. Should you need any spare parts, please order genuine parts from your local Elation dealer.

Please refer to the following points during routine inspections:

- A detailed electric check by an approved electrical engineer every three months, to make sure the circuit contacts are in good condition and prevent overheating.
- Be sure all screws and fasteners are securely tightened at all times. Loose screws may fall out during normal operation resulting in damage or injury as larger parts could fall.
- Check for any deformations on the housing, color lenses, rigging hardware and rigging points (ceiling, suspension, trussing). Deformations in the housing could allow for dust to enter into the fixture. Damaged rigging points or unsecured rigging could cause the fixture to fall and seriously injure a person(s).
- Electric power supply cables must not show any damage, material fatigue or sediments. Never remove the ground prong from the power cable.

TECHNICAL SPECIFICATIONS

FEATURES

Greater Output and 1/2 the Power of 150W Discharge
16bit Pan and Tilt Motors
Motorized Focus
Flicker Free Operation for TV and FILM

SOURCE

60W 6,500K Cool White Solid State LED Engine
60,000 Hour Average Life

PHOTOMETRIC DATA

2,636 LUX 245 FC @5M 15°

EFFECTS

3 Facet, 5 Facet, and Infinity Prisms and Macros
Variable Strobe Settings
Electronic Dimming: 0% - 100%

COLOR

8 Dichroic Colors + White

GOBOS

7 Interchangeable / Rotating / Indexing Glass Gobos
Size: OD 27mm / ID 22mm

CONTROL / CONNECTIONS

(2) DMX Channel Modes (12/14)
3pin & 5pin DMX In/Out
4 Button Control Panel
LCD Menu Display
Edison Power Cable

SIZE / WEIGHT

Length: 11.9" (301mm)
Width: 8.0" (204mm)
Vertical Height: 16.0" (407mm)
Weight: 25.0 lbs. (11.3kg)

ELECTRICAL / THERMAL

AC 100-240V - 50/60Hz
180W Max Power Consumption

APPROVALS / RATINGS

CE Approved
cETLus Approved
IP20 Rated

INSTALLATION

Rigging: Omega Bracket
Working Position: Flat Surface / Inverted (180°)

Please Note: Specifications and improvements in the design of this unit and this manual are subject to change without any prior written notice.

PHOTOMETRIC DATA

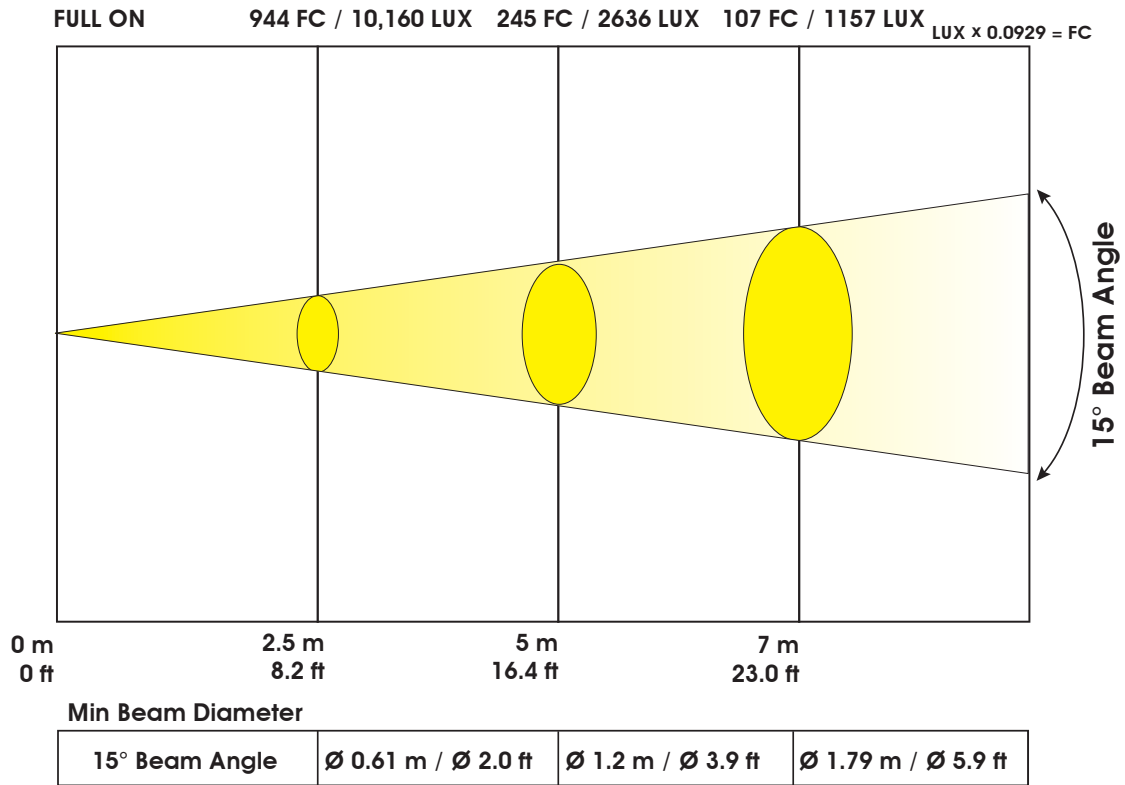

Please Note: Specifications and improvements in the design of this unit and this manual are subject to change without any prior written notice.

ROTATING GOBOS

1>



4>

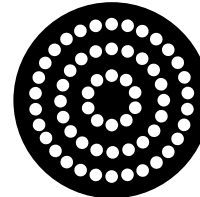
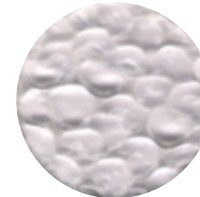
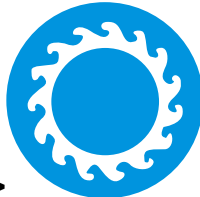

DIMENSIONAL DRAWINGS

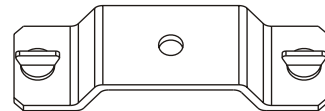
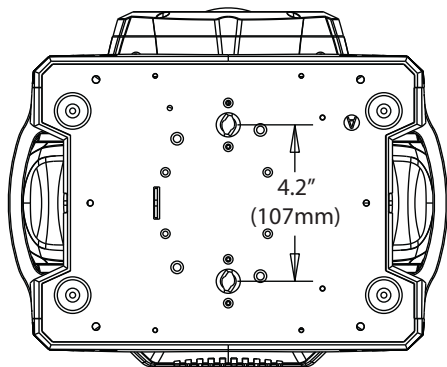
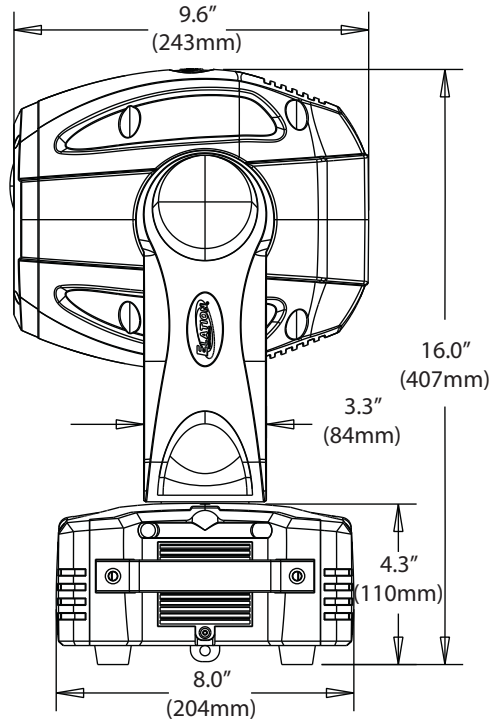
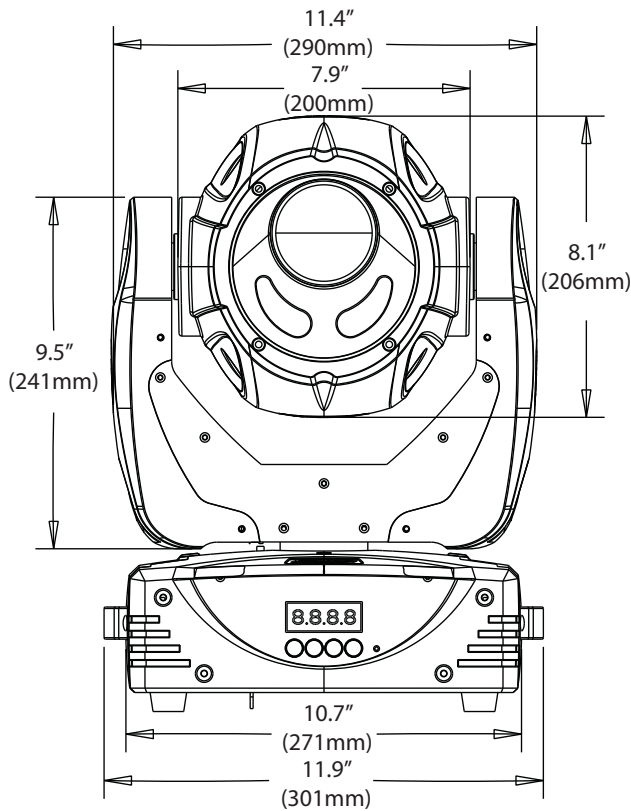

Note: Please add 3" (76.5mm) to the total height of the fixture when using the included Omega-Clamp

Please Note: Specifications and improvements in the design of this unit and this manual are subject to change without any prior written notice.

CIRCUIT SCHEMATICS

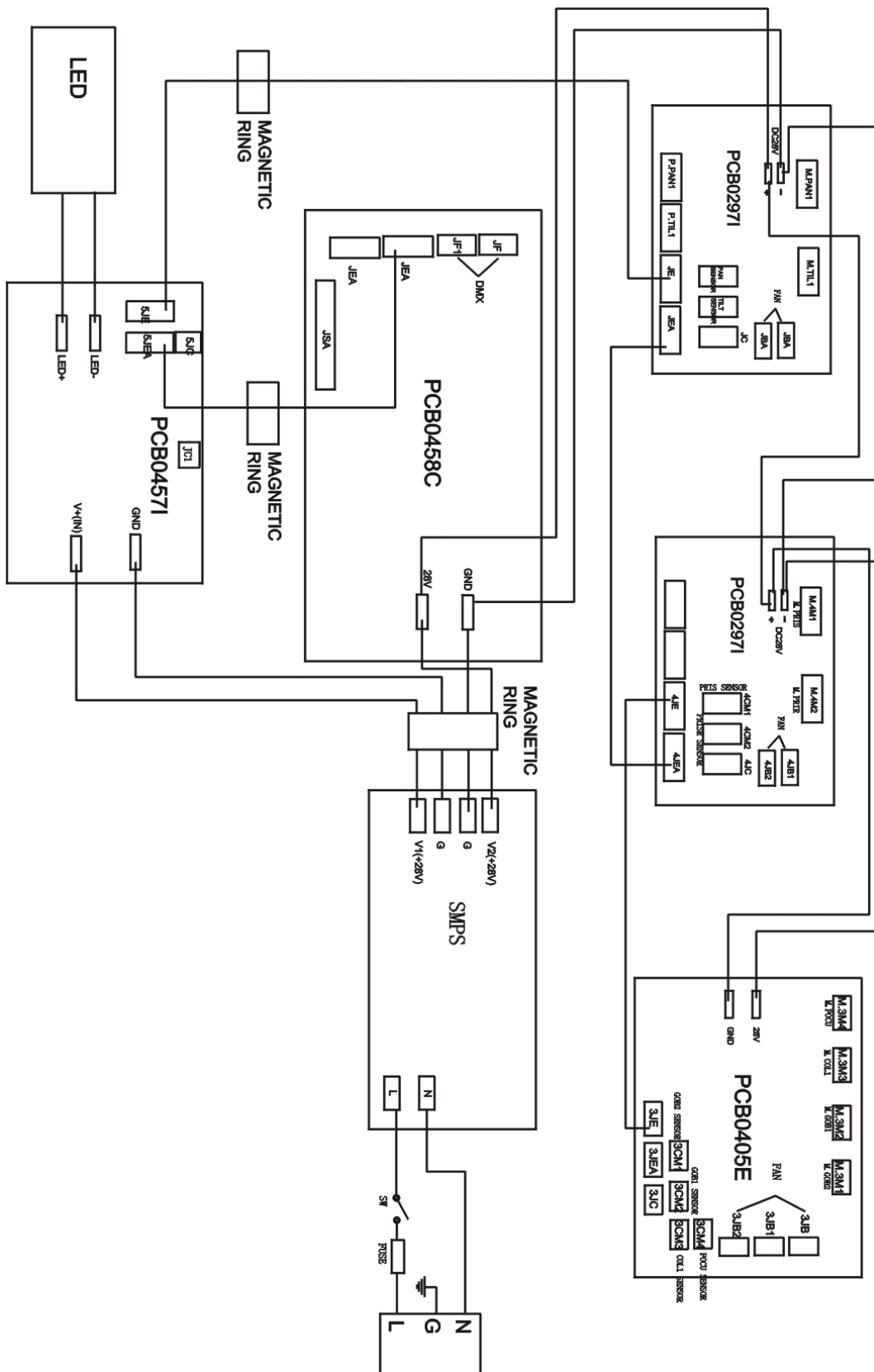

Please Note: Specifications and improvements in the design of this unit and this manual are subject to change without any prior written notice.

OPTIONAL ACCESSORIES

ORDER CODE	ITEM
TRIGGER CLAMP	Heavy Duty Wrap Around Hook Style Clamp
AC3PDMX5PRO	5 ft. (1.5m) 3pin PRO DMX Cable
AC3PDMX10PRO	10 ft. (3m) 3pin PRO DMX Cable
AC3PDMX15PRO	15 ft. (4.5m) 3pin PRO DMX Cable
AC3PDMX25PRO	25 ft. (7.5m) 3pin PRO DMX Cable
AC3PDMX50PRO	50 ft. (15m) 3pin PRO DMX Cable
AC3PDMX100PRO	100 ft. (30m) 3pin PRO DMX Cable
AC5PDMX5PRO	5 ft. (1.5m) 5pin PRO DMX Cable
AC5PDMX10PRO	10 ft. (3m) 5pin PRO DMX Cable
AC5PDMX15PRO	15 ft. (4.5m) 5pin PRO DMX Cable
AC5PDMX25PRO	25 ft. (7.5m) 5pin PRO DMX Cable
AC5PDMX50PRO	50 ft. (15m) 5pin PRO DMX Cable
AC5PDMX100PRO	100 ft. (30m) 5pin PRO DMX Cable

Declaration of Conformity

We declare that our products (lighting equipments) comply with the following specification and bears CE mark in accordance with the provision of the Electromagnetic Compatibility (EMC) Directive 89/336/EEC.

EN55103-1: 2009 ; EN55103-2: 2009; EN62471: 2008;
EN61000-3-2: 2006 + A1:2009 + A2:2009; EN61000-3-3: 2008.

&

Harmonized Standard

EN 60598-1:2008 + All:2009; EN 60598-2-17:1989 + A2:1991; EN
62471:2008; EN 62493: 2010
Safety of household and similar electrical appliances
Part 1: General requirements

