



E SPOT LED II™

SKU# EES058

The E SPOT LED II™ features a 60W 6,500K, Cool White Solid State LED engine, with greater output and 1/2 the power of a 150W discharge fixture, 16-bit pan and tilt motors, motorized focus, electronic strobe, 0-100% dimming, rotating 3 facet, 5 facet, and infinity prisms, color wheel with (8) dichroic colors plus white, gobo wheel with (7) rotating, interchangeable gobos, flicker free operation for TV and FILM, 3 and 5pin in/out DMX connections, (4) button touch control panel, 180W max power consumption, and a multi-voltage universal auto switching power supply (120-240v).

FEATURES

- 60W 6,500K Cool White Solid State LED Engine**
- Greater Output and 1/2 the Power of 150W Discharge**
- 16-bit Pan and Tilt Motors**
- Motorized Focus / Electronic Strobe / 0-100% Dimming**
- Rotating 3 Facet, 5 Facet, and Infinity Prisms**
- Color Wheel with (8) Dichroic Colors + White**
- Gobo Wheel with (7) Rotating, Interchangeable Gobos**
- Flicker Free Operation for TV and FILM**
- 180W Max Power Consumption**



ELATION | E SPOT LED II™ | Product Specification Sheet

Specifications are subject to change without notice ©Elation Professional

Elation Professional USA | 6122 S. Eastern Ave. | Los Angeles, CA. 90040
323-582-3322 | 323-832-9142 fax | www.elationlighting.com | info@elationlighting.com

Elation Professional B.V. | Junostraat 2 | 6468 EW Kerkrade, Netherlands
+31 45 546 85 66 | +31 45 546 85 96 fax | www.elationlighting.eu | info@elationlighting.eu

PRODUCT SPECIFICATIONS

FEATURES

Greater Output and 1/2 the Power of 150W Discharge
 16 bit Pan and Tilt Motors
 Motorized Focus
 Flicker Free Operation for TV and FILM

SOURCE

60W 6,500K Cool White Solid State LED Engine
 60,000 Hour Average Life

PHOTOMETRIC DATA

2,636 LUX 245 FC @5M 15°

EFFECTS

3 Facet, 5 Facet, and Infinity Prisms and Macros
 Variable Strobe Settings
 Electronic Dimming: 0% - 100%

COLOR

8 Dichroic Colors + White

GOBOS

7 Interchangeable / Rotating / Indexing Glass Gobos
 Size: OD 27mm / ID 22mm

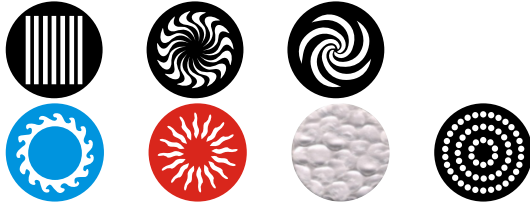

CONTROL / CONNECTIONS

(2) DMX Channel Modes (1/2/1/4)
 3pin & 5pin DMX In/Out
 4 Button Control Panel
 LCD Menu Display
 Edison Power Cable

SIZE / WEIGHT

Length: 11.9" (301mm)
 Width: 8.0" (204mm)
 Vertical Height: 16.0" (407mm)
 Weight: 25.0 lbs. (11.3kg)

ELECTRICAL / THERMAL

AC 100-240V - 50/60Hz
 180W Max Power Consumption

APPROVALS / RATINGS

CE Approved
 cETLus Approved
 IP20 Rated

INSTALLATION

Rigging: Omega Bracket
 Working Position: Flat Surface / Inverted (180°)

INCLUDED ITEMS

- (1) Omega Bracket
- (1) 3pin XLR Cable
- (1) Safety Cable

PHOTOMETRIC DATA

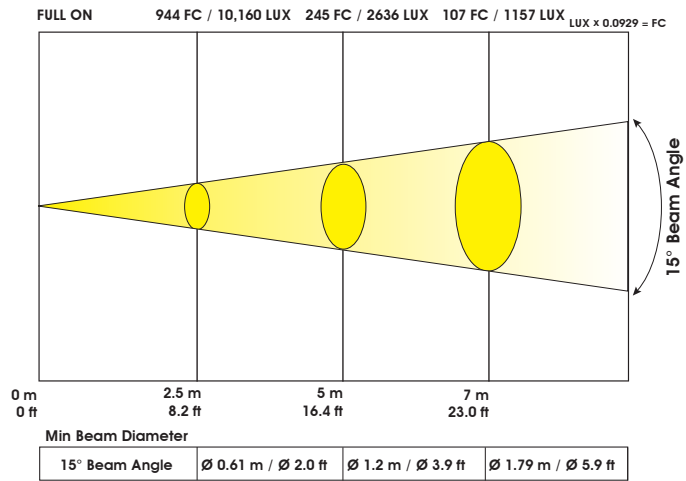

DIMENSIONAL DIAGRAM

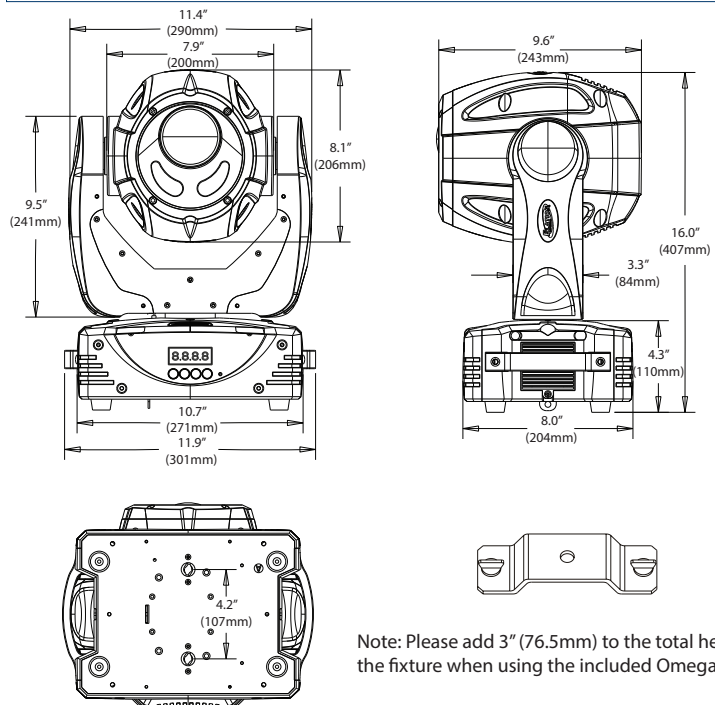

OPTIONAL ACCESSORIES

ORDER CODE	ITEM
TRIGGER CLAMP	Heavy Duty Wrap Around Hook Style Clamp
AC3PDMX5PRO	5 ft. (1.5m) 3pin PRO DMX Cable
AC3PDMX10PRO	10 ft. (3m) 3pin PRO DMX Cable
AC3PDMX15PRO	15 ft. (4.5m) 3pin PRO DMX Cable
AC3PDMX25PRO	25 ft. (7.5m) 3pin PRO DMX Cable
AC3PDMX50PRO	50 ft. (15m) 3pin PRO DMX Cable
AC3PDMX100PRO	100 ft. (30m) 3pin PRO DMX Cable
AC5PDMX5PRO	5 ft. (1.5m) 5pin PRO DMX Cable
AC5PDMX10PRO	10 ft. (3m) 5pin PRO DMX Cable
AC5PDMX15PRO	15 ft. (4.5m) 5pin PRO DMX Cable
AC5PDMX25PRO	25 ft. (7.5m) 5pin PRO DMX Cable
AC5PDMX50PRO	50 ft. (15m) 5pin PRO DMX Cable
AC5PDMX100PRO	100 ft. (30m) 5pin PRO DMX Cable

