

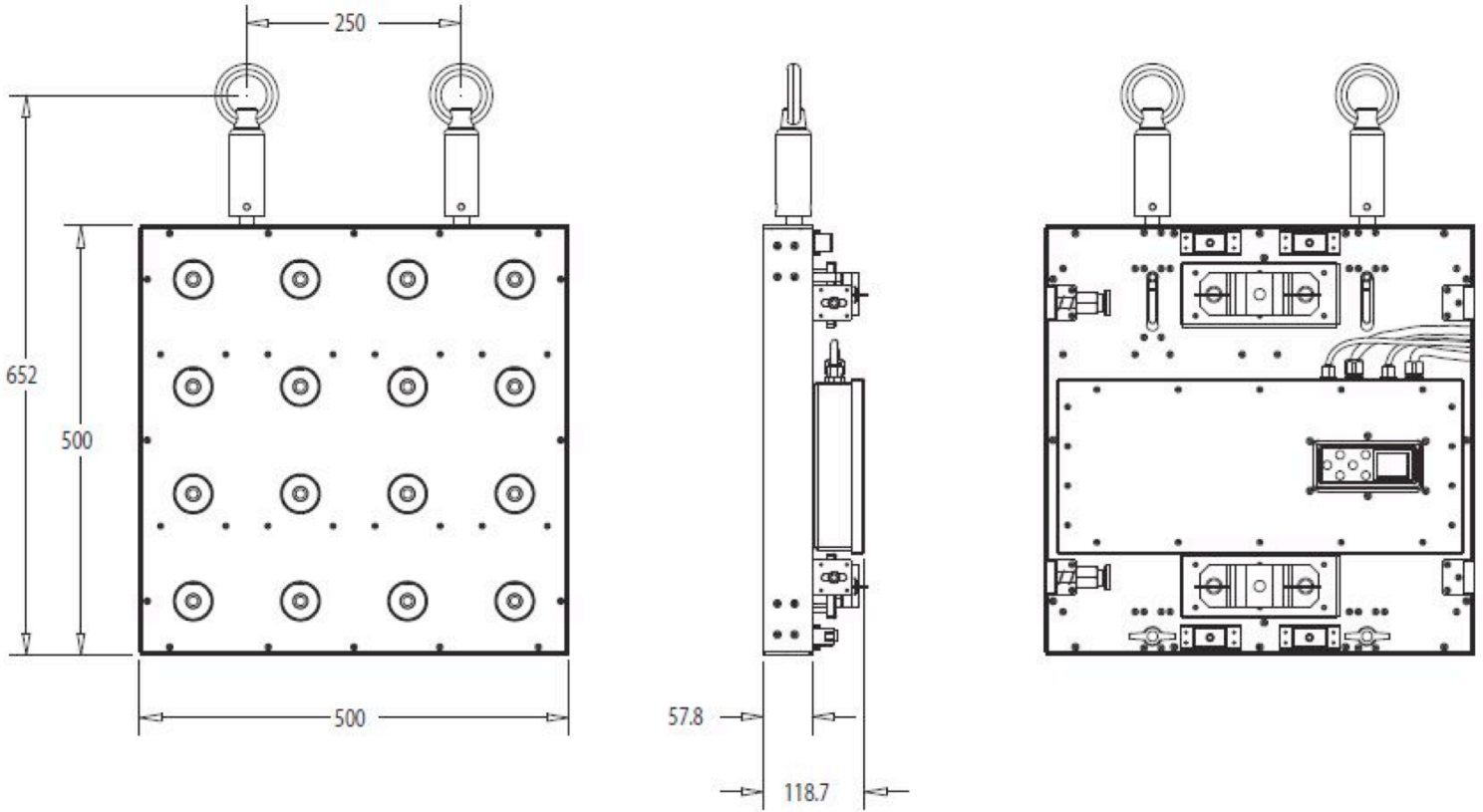

# ELAR QUAD PANEL – Dimensional Drawings

Specifications and improvements in the design of this unit are subject to change without any prior written notice.



## Elation Professional USA

6122 S. Eastern Ave.

Los Angeles, CA. 90040

323-582-3322 / 323-832-9142 fax

[www.elationlighting.com](http://www.elationlighting.com)

[info@elationlighting.com](mailto:info@elationlighting.com)

## Elation Professional B.V.

Junostraat 2

6468 EW Kerkrade, Netherlands

+31 45 546 85 66

Fax: +31 45 546 85 96

[www.elationlighting.eu](http://www.elationlighting.eu)

[info@elationlighting.eu](mailto:info@elationlighting.eu)